

Invacare® AVIVA™ RX series

AVIVA RX20, AVIVA RX40, AVIVA RX40HD



en **Power Wheelchair
Service Manual**



PROVIDER: Keep this manual.
The procedures in this manual **MUST** be performed by a qualified technician.



Yes, you can.®

© 2020 Invacare Corporation

All rights reserved. Reproduction, duplication or modification in whole or in part is prohibited without prior written permission from Invacare. Trademarks are identified by ™ and ®. All trademarks are owned by or licensed to Invacare Corporation or its subsidiaries unless otherwise noted.

Making Life's Experiences Possible is a registered trademark in the U.S.A.

Contents

1 General	4
1.1 Introduction	4
1.2 General Information	4
1.3 Symbols in this Manual	4
1.4 Images in This Manual	4
2 Safety	5
2.1 Safety information	5
2.2 Safety and Fitting Instructions	5
3 Hygiene	7
3.1 Handling of Returned Used Products	7
4 Setup	8
4.1 General information on setup	8
4.2 Adjusting Seating Position	8
4.2.1 Adjusting Lower Leg Length	8
4.2.2 Adjusting Seat Depth	8
4.2.3 Adjusting Centre of Gravity of Seat	9
4.3 Adjusting Centre of Gravity — Ultra Low Maxx Seat	9
4.4 Adjusting Centre of Gravity — Modulite Seat	12
4.4.1 Telescopic seat frame	13
4.5 Adjusting Seat Height	13
4.5.1 Adjusting Seat Height — Tilt with Fixed Pivot Point	13
5 Testing	15
5.1 Testing Motor	15
5.2 Testing Motor Brake	15
5.3 Rain test	15
5.4 Field Load Test	16
5.5 Checking Battery Charge Level	16
6 Service	18
6.1 General Warning Information on Installation Work	18
6.2 Tightening Torques	18
6.3 Glossary of Frequently Used Mounting Hardware	18
6.4 Overview Components	19
6.5 Troubleshooting	19
6.5.1 Operational Faults	19
6.5.2 Drive Fault Diagnosis	19
6.5.3 Charging device fault diagnosis	22
6.6 Service Plan (Once a Year)	22
6.7 Shrouds	24
6.7.1 Power Module Shrouds	24
6.7.2 Water Protection Shroud	25
6.7.3 Main Frame Shrouds	25
6.7.4 Battery Shroud	27
6.7.5 Rear Shroud	28
6.7.6 Replacing Fender	29
6.7.7 Replacing Front Fender on Single-Sided Fork	30
6.7.8 Replacing Front Fender on Double-Sided Fork	31
6.7.9 Replacing Rim Cap and Insert (Drive Wheel)	31
6.7.10 Replacing Rim Cap (Castor Wheel)	32
6.8 Chassis	32
6.8.1 Changing Wheelbase	32
6.8.2 Replacing Kerb Climber	33
6.8.3 Replacing Rubber Foot	34
6.8.4 Replacing Tie-Down Points	34
6.8.5 Replacing C.T.C. Suspension	35
6.8.6 Replacing and Adjusting Rear Suspension	36
6.9 Drive Components	38
6.9.1 Replacing Motor-Gearbox Unit	38
6.9.2 Replacing or rotating motor/gearbox unit sealing ring	39
6.9.3 Replacing motor/gearbox clutch	40
6.9.4 Replacing Engaging Turn Knob	40
6.9.5 Replacing Castor Fork	42
6.9.6 Replacing Castor Lock	43
6.10 Wheels	44
6.10.1 Repair Instructions	44
6.10.2 Tyre Pressure	44
6.10.3 Tyre Types	45
6.10.4 Specific Tightening Torques	45
6.10.5 Overview of Power Wheelchair Models and Wheel Types	46
6.10.6 Replacing Drive Wheel (5-Screw Installation)	48
6.10.7 Replacing Castor Wheel on Double-Sided Fork	49
6.10.8 Replacing Castor Wheels on Single-Sided Fork	51
6.10.9 Replacing Tyres	52
6.10.10 Replacing drive wheel hub	54
6.10.11 Replacing Manual Wheel Lock	54
6.10.12 Replacing Anti-Tipper Unit	55
6.10.13 Replacing Anti-Tipper Wheel	55
6.11 Electronics	56
6.11.1 Replacing Power Module	56
6.11.2 Replacing Bus Expansion Block (GLM-CONX4)	58
6.11.3 Replacing G-Trac Sensor	58
6.11.4 Replacing Operating Hour Counter/ Connecting Cable	58
6.11.5 Replacing Cable Harness	60
6.11.6 Updating Software	60
6.12 Batteries	60
6.12.1 General Instructions on Handling Batteries	61
6.12.2 Handling Damaged Batteries Correctly	61
6.12.3 Making Batteries Accessible	61
6.12.4 Replacing Batteries	61
6.12.5 Replacing Circuit Breaker	62
6.12.6 Checking Cables	64
6.13 Lighting unit	65
6.13.1 Replacing Headlight	65
6.13.2 Replacing Headlight Holder	65
6.13.3 Replacing Rear Light	66
6.14 Seating	66
6.14.1 Replacing Actuator/Spindle — Tilt with Fixed Pivot Point	66
6.14.2 Replacing Height Adjustment Bracket — Tilt and Lifter-Tilt Modules	67
6.15 Options	68
6.15.1 Replacing Luggage Carrier	68
7 Mounting Dahl Docking System	70

1 General

1.1 Introduction

This document contains important information about assembly, adjustment and advanced maintenance of the product. To ensure safety when handling the product, read this document and the user manual carefully and follow the safety instructions.

Find the user manual on Invacare's website or contact your Invacare representative. See addresses at the end of this document.

Invacare reserves the right to alter product specifications without further notice.

Before reading this document, make sure you have the latest version. You find the latest version as a PDF on the Invacare website.

For pre-sale and user information, see the user manual.

For more information about the product, for example product safety notices and product recalls, contact your Invacare representative. See addresses at the end of this document.

1.2 General Information

Service and maintenance work must be carried out taking this document into account.

It is imperative that you observe safety information.

Information about operation or about general maintenance and care work on the product should be taken from service manual.

Assembly of accessories might not be described in this document. Refer to the manual delivered with the accessory. Additional manuals can be ordered from Invacare. See addresses at the end of this document.

You can find information about ordering spare parts in the spare parts catalogue.

Spare parts must match original Invacare parts. Only use spare parts which have been approved by Invacare.

The product may only be maintained and overhauled by qualified personnel.

The minimum requirement for service technicians is suitable training, such as in the cycle or orthopedic mechanics fields, or sufficiently long-term job experience. Experience in the use of electrical measuring equipment (multimeters) is also a requirement. Special Invacare training is recommended.

Alterations to the mobility device which occur as a result of incorrectly or improperly executed maintenance or overhaul work lead to the exclusion of all liability on the side of Invacare.

If you have any problems or questions contact your provider.

1.3 Symbols in this Manual

Symbols and signal words are used in this manual and apply to hazards or unsafe practices which could result in personal injury or property damage. See the information below for definitions of the signal words.



DANGER

Indicates a hazardous situation that will result in serious injury or death if it is not avoided.



WARNING

Indicates a hazardous situation that could result in serious injury or death if it is not avoided.



CAUTION

Indicates a hazardous situation that could result in minor or slight injury if it is not avoided.



IMPORTANT

Indicates a hazardous situation that could result in damage to property if it is not avoided.



Gives useful tips, recommendations and information for efficient, trouble-free use.



Identifies required tools, components and items which are needed to carry out certain work.

1.4 Images in This Manual

The detailed images in this manual are given marks to identify various components. Component marks in text and operational instructions always relate to the image directly above.

2 Safety

2.1 Safety information



WARNING!

The procedures in this service manual, must be performed by a specialized dealer or qualified service technician.

- Do not handle this product or any available optional equipment without first completely reading and understanding these instructions and any additional instructional material such as user manuals, installation manuals or instruction sheets supplied with this product or optional equipment.



The information contained in this document is subject to change without notice.

2.2 Safety and Fitting Instructions

These safety instructions are intended to prevent accidents at work, and it is imperative that they are observed.

Before any inspection or repair work

- Read and observe this repair manual and the associated user manual.
- Observe the minimum requirements for carrying out the work (see *1.2 General Information, page 4*).

Personal Safety Equipment

Safety shoes

The mobility device, and some of its components, are very heavy. These parts can result in injuries to the feet if they are allowed to drop.

- Wear standardized safety shoes during all work.

Eye protection

It is possible that battery acid can be discharged when working on defective batteries or when handling batteries improperly.

- Always wear eye protection when working on any defective or possibly defective batteries.

Safety gloves

It is possible that battery acid can be discharged when working on defective batteries or when handling batteries improperly.

- Always wear acid-proof safety gloves when working on any defective or possibly defective batteries.

General Safety Information and Information About Fitting / Removal



DANGER!

Risk of Death, Serious Injury, or Damage

Lighted cigarettes dropped onto an upholstered seating system can cause a fire resulting in death, serious injury, or damage. Mobility device occupants are at particular risk of death or serious injury from these fires and resulting fumes because they may not have the ability to move away from the mobility device.

- DO NOT smoke while using this mobility device.



WARNING!

Risk of Serious Injury or Damage

Storing or using the mobility device near open flame or combustible products can result in serious injury or damage.

- Avoid storing or using the mobility device near open flame or combustible products.



CAUTION!

Risk of crushing

Various components such as the drive unit, batteries, seat etc are very heavy. This results in injury hazards to your hands.

- Note the high weight of some components. This applies especially to the removal of drive units, batteries and the seat.



CAUTION!

Injury hazard if the mobility device starts moving unintentionally during repair work

- Switch the power supply off (ON/OFF key).
- Engage the drive.
- Before lifting up, secure the mobility device by using chocks to block the wheels.



CAUTION!

Fire and burn hazard due to electrical short-circuit

- The mobility device must be completely switched off before removal of voltage-carrying components! To do this, remove the batteries.
- Avoid short-circuiting the contacts when carrying out measurements on voltage-carrying components.



CAUTION!

Risk of burns from hot surfaces on the motor

- Allow the motors to cool down before commencing work on them.



CAUTION!

Injury hazard and risk of damage to mobility device due to improper or incomplete maintenance work

- Use only undamaged tools in good condition.
- Some moving parts are mounted in sockets with PTFE coating (Teflon™). Never grease these sockets!
- Never use "normal" nuts instead of self-locking nuts.
- Always use correctly-dimensioned washers and spacers.
- When reassembling, always replace any cable ties which were cut during dismantling.
- After completing your work / before renewed start-up of the mobility device, check all connections for tight fitting.
- After completing your work / before renewed start-up of the mobility device, check all parts for correct locking.
- Only operate the mobility device with the approved tyre pressures (see technical data).
- Check all electrical components for correct function. Note that incorrect polarity can result in damage to the control system.
- Always carry out a trial run at the end of your work.



CAUTION!

Risk of injury and damage to property, if the maximum speed reduction on a wheelchair with a lifter does not function correctly

The wheelchair's control unit must reduce the maximum possible speed as soon as the lifter is raised.

- Test the maximum speed reduction for correct function after any maintenance work or modifications to the wheelchair.



CAUTION!

Any changes to the drive program can affect the driving characteristics and the tipping stability of the mobility device

- Changes to the drive program may only be carried out by trained Invacare providers.
- Invacare supplies all mobility devices with a standard drive program ex-works. Invacare can only give a warranty for safe mobility device driving behavior - especially tipping stability - for this standard drive program.



Mark all current settings for the mobility device (seat, armrests, backrest etc.), and the associated cable connecting plugs, before dismantling. This makes reassembly easier. All plugs are fitted with mechanical locks which prevent release of the connecting plugs during operation. To release the connecting plugs the safety locks must be pressed in. When reassembling ensure that these safety locks are correctly engaged.

3 Hygiene

3.1 Handling of Returned Used Products

When reconditioning or repairing returned mobility devices:

- Take precautions for yourself and the product.
- Use protection equipment as specified locally.

Before Transport (According to Biological Agents Ordinance)

Treat product according to following process steps:

Process Step	Component	Application	Conditioning technique	Work Station
Manual cleaning	Surface of used device	Before repair or reconditioning	Use saturated towel to apply cleaning detergent and remove residues after impact.	Cleaning and disinfection
Disinfection	Surface of used device	Before repair or reconditioning	Use saturated disinfectant wipes and clean* the device surface.	Cleaning and disinfection

*Invacare uses detergent "Nücosept special" 1.5% in water ml/ml

Disinfection Tools

- Disposable wipes (fleece)
- Brushes to clean areas difficult to access

Further Information



For more information contact your Invacare service department.

4 Setup

4.1 General information on setup

The tasks described in this chapter are intended to be performed by trained and authorized service technicians for initial setup. They are not intended to be performed by the user.

4.2 Adjusting Seating Position

Adjusting the seating position in order to adapt the mobility device optimally to the requirements of the user, we recommend that you ask your authorised Invacare provider to adjust seat depth individually. Adapting the seat to the user's seating position depends on the seat that has been fitted, and should be carried out in the following sequence.

1. Adjusting the lower leg length and seat depth. See 4.2.1 *Adjusting Lower Leg Length*, page 8 and 4.2.2 *Adjusting Seat Depth*, page 8.
2. Adjusting the center of gravity of the seat frame. See 4.2.3 *Adjusting Centre of Gravity of Seat*, page 9.
3. Checking that the swivel castors can move freely.
4. Repetition of steps 2 to 4, if necessary.



WARNING!

Risk of injury after tilting of mobility device caused by blocked steering wheels

- Always check the seat depth settings for both forward and reverse movement. Make sure that steering wheels can rotate freely and have not contact to any fixed mobility device component.



WARNING!

Any changes to the drive program can affect the driving characteristics and the tipping stability of the mobility device

- Changes to the drive program may only be carried out by trained Invacare providers.
- Invacare supplies all mobility devices with a standard drive program ex-works. Invacare can only give a warranty for safe vehicle driving behavior - especially the tipping stability - for this standard drive program.



WARNING!

Risk of crushing

The seat is very heavy. Risk of injury to hands and feet.

- Pay attention to the hand and feet.
- Use proper lifting techniques.



CAUTION!

Risk of tipping over

Any change in the seating position can negatively influence the stability of the mobility device.

- Always make sure that the mobility device is stable and will not tip over, after adjusting seating position.

4.2.1 Adjusting Lower Leg Length

Invacare offers a range of legrests which can be adjusted individually. See user manual.

4.2.2 Adjusting Seat Depth

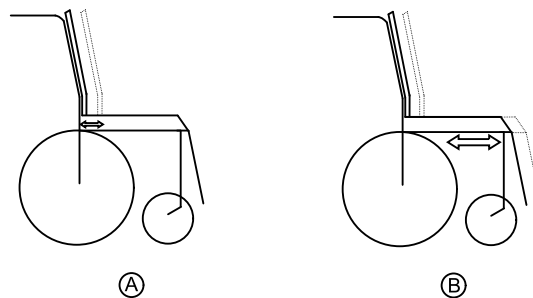

A: Seat depth

B: Centre of gravity of the seat/ seat position

Modulite Seat

The seat depth **A** can be adjusted by moving the position of the backrest in relation to the seat surface. See user manual of Modulite.

Ultra Low Maxx Seat

The seat depth (A) can be adjusted by moving the position of side rails with front seat plates in relation to the backrest. See user manual of Ultra Low Maxx.

4.2.3 Adjusting Centre of Gravity of Seat

The centre of gravity of seat (CoG) can be adjusted by mounting seat frame farther towards front or the rear of seat.



CAUTION!

The seating system of the mobility device is delivered ex works with a standard adjustment of centre of gravity (CoG), which meets 80 % – 90 % of user requirements. CoG can be adjusted individually. However, any change in this adjustment setting can negatively influence the stability of the mobility device.

– You must perform an individual risk analysis every time you change the centre of gravity of the seating position, in order to ensure the safety and stability of the mobility device.

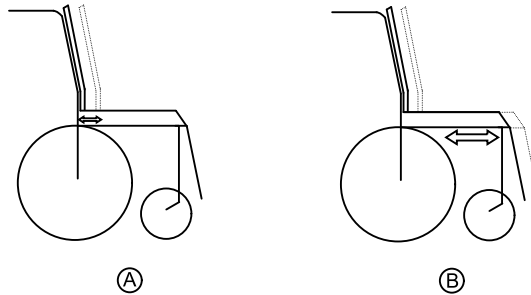

A: Seat depth

B: centre of gravity of the seat/ seat position



The user weight and seat depth have strong influences on the choice of the centre of gravity (CoG). If the user is heavy and the seat depth is greater, the focus should be the farther back. For best possible driving characteristics of rear-wheel drive mobility devices, the weight should be distributed: 30 % – 40 % front and 60 % - 70 % rear. For center wheel drives the weight should be distributed 25 % front, 50 % center and 25 % rear.

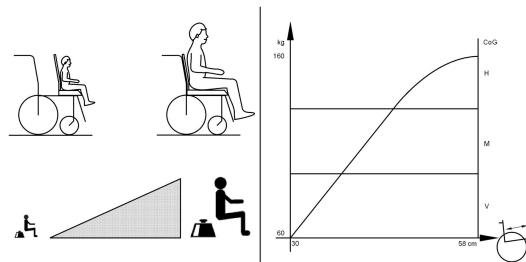

CAUTION!

Risk of damage due to collisions of the legrests with other parts of the mobility device

- Set the legrests to the smallest angle before adjusting the seat centre of gravity.
- Pay attention with adjusting seat centre of gravity that legrests do not touch any other parts of mobility device. This ensures that the legrests can not collide with other parts of mobility device.

Seat systems

For details on Modulite seat and Ultra Low Maxx seat see the following sections.

4.3 Adjusting Centre of Gravity — Ultra Low Maxx Seat



- 4 mm Allen key

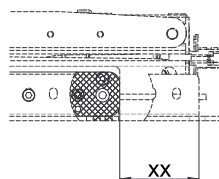

Fig. 4-1

The following tables list the recommended module positions depending on the wheelbase length and the seat depth. The xx value is the distance between the rear edge of the height-adjustment bracket and the rear edge of the main frame.

Variant narrow base — Recommended positions of module

Wheelbase	Seat Depth	Tilt and Lifter-Tilt Modules		Tilt with Fixed Pivot Point	
		Distance XX	Comment	Distance XX	Comment
460 mm	405 mm/ 16 inch	N/A	N/A	72.5 mm	Best performance
	430 mm/ 17 inch	N/A	N/A	50.0 mm	Best performance
	455 mm/ 18 inch	N/A	N/A	27.5 mm	Best performance
	480 mm/ 19 inch	N/A	N/A	27.5 mm	Performance considerations
	505 mm/ 20 inch	N/A	N/A	27.5 mm	Performance considerations
	530 mm/ 21 inch	N/A	N/A	N/A	N/A
	555 mm/ 22 inch	N/A	N/A	N/A	N/A
	580 mm/ 23 inch	N/A	N/A	N/A	N/A
490 mm	405 mm/ 16 inch	72.5 mm	Best performance	72.5 mm	Performance considerations
	430 mm/ 17 inch	50.0 mm	Best performance	50.0 mm	Performance considerations
	455 mm/ 18 inch	27.5 mm	Best performance	27.5 mm	Performance considerations
	480 mm/ 19 inch	27.5 mm	Performance considerations	5.0 mm	Best performance
	505 mm/ 20 inch	27.5 mm	Performance considerations	5.0 mm	Best performance
	530 mm/ 21 inch	N/A	N/A	N/A	N/A
	555 mm/ 22 inch	N/A	N/A	N/A	N/A
	580 mm/ 23 inch	N/A	N/A	N/A	N/A
520 mm	405 mm/ 16 inch	72.5 mm	Performance considerations	72.5 mm	Performance considerations
	430 mm/ 17 inch	50.0 mm	Performance considerations	50.0 mm	Performance considerations
	455 mm/ 18 inch	27.5 mm	Performance considerations	27.5 mm	Performance considerations
	480 mm/ 19 inch	5.0 mm	Best performance	5 mm	Performance considerations
	505 mm/ 20 inch	5.0 mm	Best performance	-17.5 mm	Performance considerations
	530 mm/ 21 inch	N/A	N/A	-17.5 mm	Best performance
	555 mm/ 22 inch	N/A	N/A	-40.0 mm	Best performance
	580 mm/ 23 inch	N/A	N/A	-40.0 mm	Best performance

Variant wide base — Recommended positions of module

Wheelbase	Seat Depth	Tilt and Lifter-Tilt Modules		Tilt with Fixed Pivot Point	
		Distance XX	Comment	Distance XX	Comment
490 mm	405 mm/ 16 inch	95.0 mm	Best performance	95.0 mm	Best performance
	430 mm/ 17 inch	72.5 mm	Best performance	72.5 mm	Best performance
	455 mm/ 18 inch	50.0 mm	Best performance	50.0 mm	Best performance
	480 mm/ 19 inch	50.0 mm	Performance considerations	27.5 mm	Best performance
	505 mm/ 20 inch	50.0 mm	Performance considerations	27.5 mm	Best performance
	530 mm/ 21 inch	N/A	N/A	N/A	N/A
	555 mm/ 22 inch	N/A	N/A	N/A	N/A
	580 mm/ 23 inch	N/A	N/A	N/A	N/A
520 mm	405 mm/ 16 inch	95.0 mm	Performance considerations	95.0 mm	Performance considerations
	430 mm/ 17 inch	72.5 mm	Performance considerations	72.5 mm	Performance considerations
	455 mm/ 18 inch	50.0 mm	Best performance	50.0 mm	Performance considerations
	480 mm/ 19 inch	27.5 mm	Best performance	27.5 mm	Performance considerations
	505 mm/ 20 inch	27.5 mm	Best performance	5.0 mm	Performance considerations
	530 mm/ 21 inch	N/A	N/A	5.0 mm	Best performance
	555 mm/ 22 inch	N/A	N/A	-17.5 mm	Best performance
	580 mm/ 23 inch	N/A	N/A	-17.5 mm	Best performance
550 mm	405 mm/ 16 inch	95.0 mm	Performance considerations	95.0 mm	Performance considerations
	430 mm/ 17 inch	72.5 mm	Performance considerations	72.5 mm	Performance considerations
	455 mm/ 18 inch	50.0 mm	Performance considerations	50.0 mm	Performance considerations
	480 mm/ 19 inch	27.5 mm	Performance considerations	27.5 mm	Performance considerations
	505 mm/ 20 inch	5.0 mm	Performance considerations	5.0 mm	Performance considerations
	530 mm/ 21 inch	5.0 mm	Best performance	-17.5 mm	Performance considerations
	555 mm/ 22 inch	5.0 mm	Best performance	-40.0 mm	Performance considerations
	580 mm/ 23 inch	5.0 mm	Best performance	-40.0 mm	Performance considerations

1. Remove main frame shrouds on both sides. See 6.7 *Shrouds, page 24*.
2. Remove screws (A) and washers (B) on both sides.
3. Align module according to table for your variant.
4. Insert screws and washers and tighten.
5. Re-install shrouds.

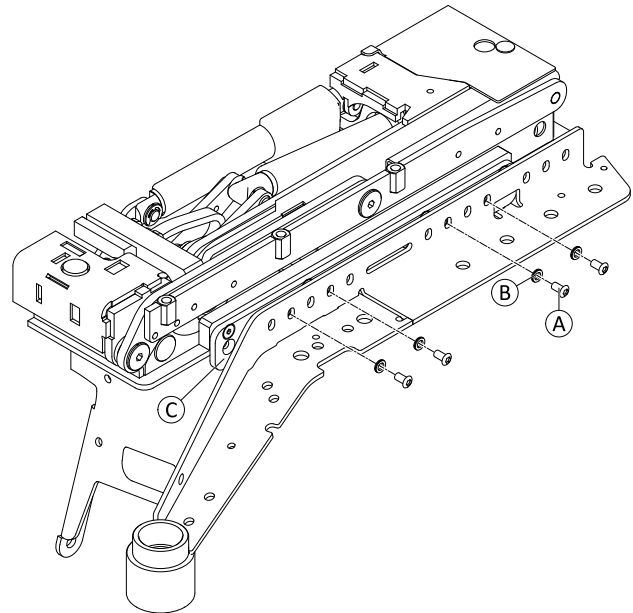

Fig. 4-2

4.4 Adjusting Centre of Gravity — Modulite Seat

On the Modulite seat, the centre of gravity is adjusted via the lateral profiles. See 4.4.1 *Telescopic seat frame, page 13*.

The following tables list the recommended module positions depending on the wheelbase length and the seat depth. The xx value is the distance between the rear edge of the height-adjustment bracket and the rear edge of the main frame.

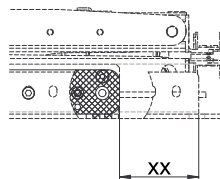

Fig. 4-3

Variant narrow base — Recommended positions of module

Wheelbase	Seat Depth	Distance XX	Comment
460 mm	405 mm/ 16 inch	N/A	N/A
	455 mm/ 18 inch	N/A	N/A
	505 mm/ 20 inch	N/A	N/A
490 mm	405 mm/ 16 inch	50.0 mm	Best performance
	455 mm/ 18 inch	50.0 mm	Best performance
	505 mm/ 20 inch	72.5 mm	Best performance
520 mm	405 mm/ 16 inch	50.0 mm	Performance considerations
	455 mm/ 18 inch	50.0 mm	Performance considerations
	505 mm/ 20 inch	50.0 mm	Performance considerations

Variant wide base — Recommended positions of module

Wheelbase	Seat Depth	Distance XX	Comment
490 mm	405 mm/ 16 inch	50.0 mm	Best performance
	455 mm/ 18 inch	50.0 mm	Best performance
	505 mm/ 20 inch	72.5 mm	Best performance
520 mm	405 mm/ 16 inch	50.0 mm	Performance considerations
	455 mm/ 18 inch	50.0 mm	Performance considerations
	505 mm/ 20 inch	50.0 mm	Performance considerations

Wheelbase	Seat Depth	Distance XX	Comment
550 mm	405 mm/ 16 inch	50.0 mm	Performance considerations
	455 mm/ 18 inch	50.0 mm	Performance considerations
	505 mm/ 20 inch	50.0 mm	Performance considerations

4.4.1 Telescopic seat frame



- 6 mm Allen key

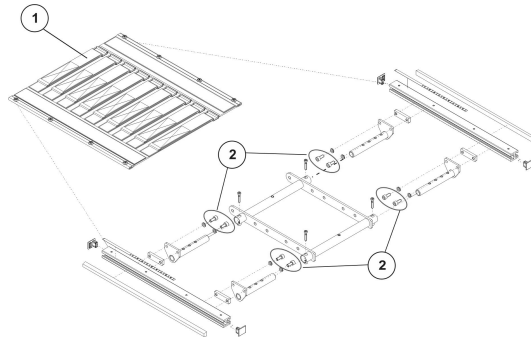

1. Remove seat plate or sling seat (1), see chapter “Adjusting seat width” in Modulite service manual.
2. Loosen Allen screws (2) in front and rear, left and right – DO NOT remove.
3. Shift position of seat.
4. Tighten screws.
5. Install seat plate or sling seat.

4.5 Adjusting Seat Height

How you adjust the seat height depends on the seating system and the tilt mechanism.

Modulite seat		See 6.14.2 Replacing Height Adjustment Bracket — Tilt and Lifter-Tilt Modules, page 67.
Ultra Low Maxx seat	Tilt and lifter-tilt modules	
	Tilt with fixed pivot point	See 4.5.1 Adjusting Seat Height — Tilt with Fixed Pivot Point, page 13.

4.5.1 Adjusting Seat Height — Tilt with Fixed Pivot Point

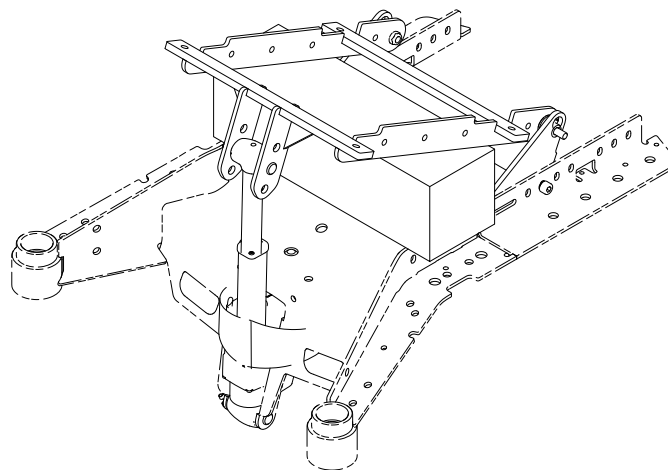

Fig. 4-4



- 10 mm wrench
- Flat screwdriver
- Oblong wooden block (at least 7.5 cm x 7.5 cm x 35 cm)

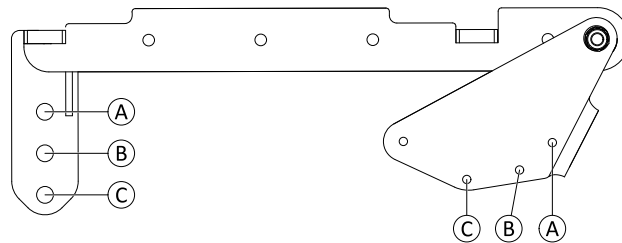

Fig. 4-5

Available settings

Mounting Position	Seat Height
Ⓐ	435 mm
Ⓑ	460 mm
Ⓒ	485 mm



CAUTION!

Risk of Crushing

Seat comes down when front or rear fixing of the seat are removed.

- Do not remove front and rear fixing of the seat at the same time.
- Hold the seat in position while removing the actuator.
- Place a wooden block between seat and chassis, or lower seat carefully to the chassis.

1. Remove SL retainer clip Ⓓ and pin Ⓔ on top fixation of actuator. Hold seat in position.
2. Adjust seat height on top fixation according to table *Available settings, page 14.*
3. Re-install SL retainer clip and pin.

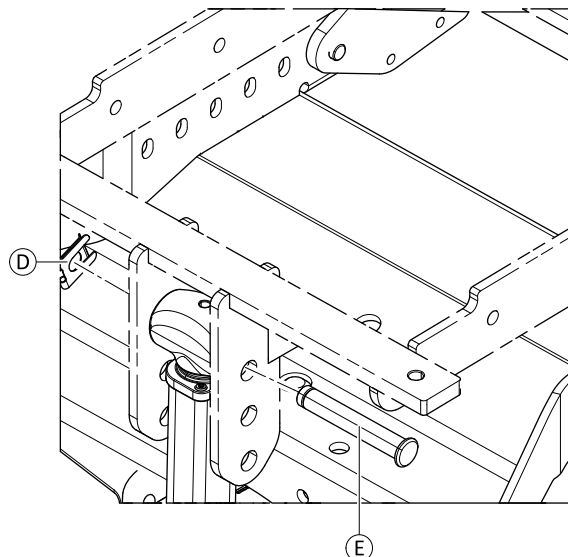

Fig. 4-6

4. Loosen screws Ⓕ on both sides slightly.
5. Loosen and remove screws Ⓒ and washers Ⓖ on both sides.
6. Adjust seat height at height adjustment bracket Ⓘ according to table *Available settings, page 14.*
7. Re-install washers and screws.
8. Tighten screws.

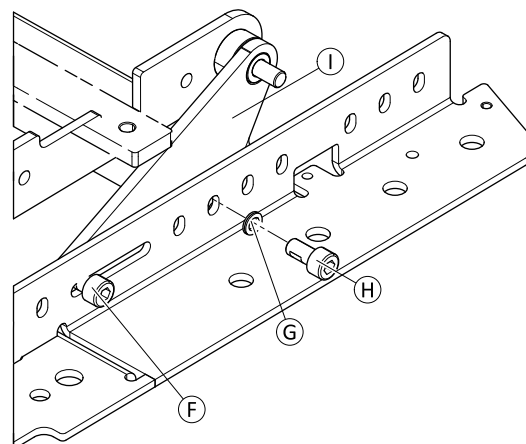





Fig. 4-7

5 Testing

5.1 Testing Motor

-  • Phillips screwdriver, size 2
-  • Digital multimeter with resistance measurement

1. Remove shroud that covers power module. See 6.7 *Shrouds, page 24*.
2. Unplug cable of motor (A) from power module.
3. Connect multimeter (B) to motor plug contacts (C) and (D) and measure resistance between contacts.

 A resistance of between 0.5 ohms and 5 ohms indicates a motor ready for operation. A resistance of between 15 ohms and infinity indicates a defective motor. High resistances are normally caused by bad connections or worn carbon brushes.

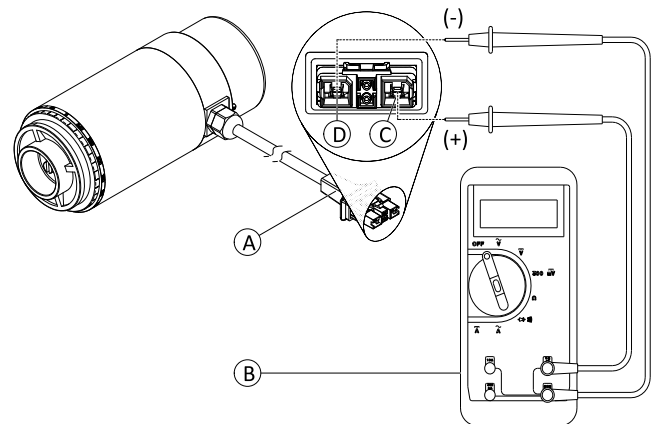



Fig. 5-1 DuraWatt motor serves as an example.

5.2 Testing Motor Brake

 This test should only be carried out on mobility device with conventional motor-gearbox units.





CAUTION!

Risk of damage to power module due to shorts in motor brake

- NEVER connect a shorted motor brake to an intact power module.
- Always replace shorted brakes immediately.

 A defective motor can damage the power module, but a defective power module cannot damage the motor.

-  • Phillips screwdriver, size 2
-  • Digital multimeter with resistance measurement

1. Remove shroud that covers power module. See 6.7 *Shrouds, page 24*.
2. Unplug cable of motor (A) from power module.
3. Connect multimeter (B) to motor plug contacts (E) and (F) and measure resistance between contacts.

 A resistance of between 40 ohms and 80 ohms indicates an intact brake. A resistance of 0 ohms or a very high resistance (mega-ohms or infinity) indicates a short-circuit, a bad connection or a defective brake.

4. If there is a defect, replace motor and send it to Invacare Service for inspection or repair.

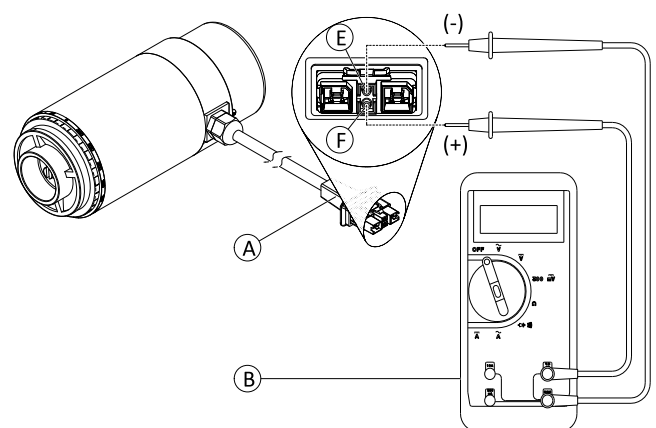



Fig. 5-2 DuraWatt motor serves as an example.

5.3 Rain test

- Check to ensure that the black battery terminal caps are secured in place, gaiter is not torn or cracked where water can enter and that all electrical connections are secure at all times.
- Do not use the mobility device if the gaiter is torn or cracked. If the gaiter becomes torn or cracked, replace immediately.

5.4 Field Load Test

Old batteries lose their ability to store and release power due to increased internal resistance. In this procedure, batteries are tested under load using a digital voltmeter to check battery charge level at the charger connector. The charger connector is located on the remote. When voltage at the output drops 1.0 volts under load (2.0 volts for a pair), replace the batteries.

 Read these instructions carefully and the manufacturer’s instructions on the digital voltmeter before proceeding.

-  • Voltmeter



WARNING!

– When performing the following steps, ensure your feet are clear from casters and wall, otherwise injury may result.

1. Switch electronics OFF on remote.
2. Make sure battery is fully charged. An extremely discharged battery will exhibit the same symptoms as a bad battery.
3. Remove footboard/legrests from mobility device.
4. Connect voltmeter leads to charger connector **A** on mobility device. Most digital voltmeters **B** are not affected by polarity. However, analog meters (meters with swinging needles) can be and should be used carefully.

 A good meter reading should be 25.5 VDC to 26.0 VDC with the chair in neutral.

5. Switch electronics ON on remote.
6. Ensure that your feet are clear from casters and wall.
7. Run mobility device in neutral for at least 2 minutes.
8. Sit in mobility device and place your feet against a door jam, workbench or other stationary object.
9. Carefully give forward command, trying to drive the mobility device through the stationary object. The load should draw between 30 amps to 40 amps from the batteries for 0.3 seconds.

 Performing this step puts a heavy load on the batteries as they try to push through the stationary object. If the wheels spin, have two individuals (one on each arm) apply as much downward pressure as possible on the arms of the mobility device.

10. Read meter while motors are straining to determine voltage under load.

 If the voltage drops more than 2.0 volts from a pair of fully charged batteries during the 0.3 seconds, they should be replaced regardless of the unloaded voltages.

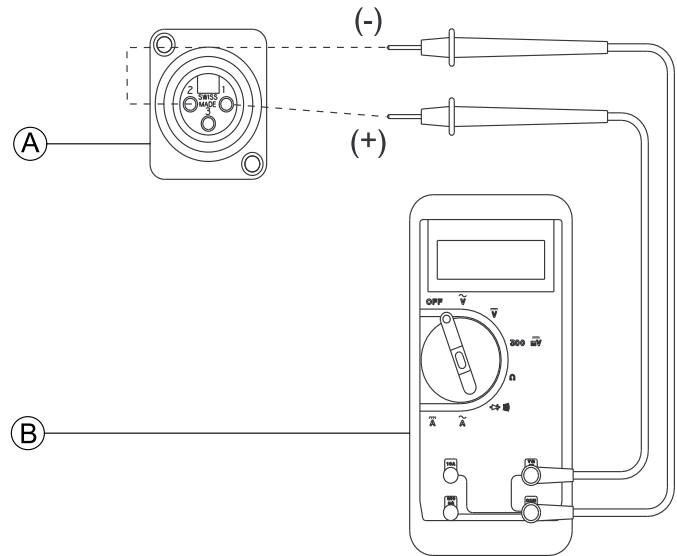

Fig. 5-3

5.5 Checking Battery Charge Level

The following “Dos” and “Don’ts” are provided for your convenience and safety.

DON'T	DO
Don't perform any installation or maintenance without first reading this manual.	Read and understand this manual and any service information that accompanies a battery and charger before operating the personal transporter.
Don't perform installation or maintenance of batteries in an area that could be damaged by battery spills.	Move the personal transporter to a work area before cleaning terminals, or opening battery box.
Don't make it a habit to discharge batteries to the lowest level.	Recharge as frequently as possible to maintain a high charge level and extend battery life.

DON'T	DO
Don't use chargers or batteries that are not appropriate for the chair.	Follow recommendations in this manual when selecting a battery or charger.
Don't put new batteries into service before charging.	Fully charge a new battery before using.
Don't tip or tilt batteries.	Use a carrying strap to remove, move or install a battery.
Don't tap on clamps and terminals with tools.	Push battery clamps on the terminals. Spread clamps wider if necessary.

6 Service

6.1 General Warning Information on Installation Work



CAUTION!

Risk of injury and damage to property, if the maximum speed reduction on a mobility device with a lifter does not function correctly

The mobility device's electronics must reduce the maximum possible speed as soon as the lifter is raised above 100 mm.

- Test the maximum speed reduction for correct function after any maintenance work or modifications to the mobility device.

6.2 Tightening Torques



CAUTION!

Risk of damage to mobility device due to improperly tightened screws, nuts or plastic connections.





- Always tighten screws, nuts etc. to the stated tightening torque.
- Only tighten screws or nuts which are not listed here fingertight.

The tightening torques stated in the following list are based on the thread diameter for the nuts and bolts for which no specific values have been determined. All values assume dry and de-greased threads.

Thread	Tightening Torque in Nm $\pm 10\%$
M4	3 Nm
M5	6 Nm
M6	10 Nm
M8	25 Nm
M10	49 Nm
M12	80 Nm
M14	120 Nm
M16	180 Nm

6.3 Glossary of Frequently Used Mounting Hardware

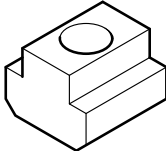
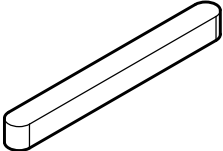
Some mounting hardware may be difficult to identify in the drawings within this document. For easier identification, see the following table for common mounting hardware delivered with our mobility devices and spare parts.

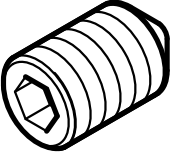
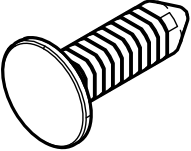
Wedge lock washer		SL retainer clip	
T-nut		Feather key	
Shaft retaining ring		Set screw	
Cone-shaped pin			

6.4 Overview Components

6.5 Troubleshooting

6.5.1 Operational Faults

Proceed as follows if you have any problems:

1. First assess the possible cause of the problem using the following table.
2. Check the remote status display. Evaluate the flash error code.
3. Carry out the necessary checks and repairs as recommended in the following table.

The various power modules can be fitted in connection with different remotes in the mobility device. Rectification of operational faults depends on the power module fitted. The power modules used are described in the corresponding controls manual.



The tables for rectification of operational faults listed in the following chapters are only an excerpt from the original manufacturer's manuals. You can obtain the original manuals from Invacare.

6.5.2 Drive Fault Diagnosis

Problem	Other symptoms	Possible cause	Solution	Documentation
Mobility device will not start	The remote status display illuminates normally and shows an error code.	Drive motors disengaged	Engage drive motors.	See user manual.
	Remote status display does not illuminate	Batteries defective	Replace batteries.	See 6.12 Batteries, page 60.
		Completely discharged battery	Pre-charge batteries.	See user manual.
		Power supply to remote interrupted	Check status of circuit breaker.	See user manual.
			Check cables between modules for loose connections or damage.	See 6.12.6 Checking Cables, page 64.
	Remote defective	Replace remote.	See 6.11.1 Replacing Power Module, page 56.	
Remote status display flashing	Various causes	Assess error code.	See remote manual.	
Mobility device judders in drive mode	None	Batteries defective (unstable voltage)	Replace batteries.	See 6.12 Batteries, page 60.
		Drive motor(s) defective	Replace motor(s).	See 6.9.1 Replacing Motor-Gearbox Unit, page 38.
Mobility device pulls to left or right	None	Drive motors running asymmetrically	Change programming to synchronise motors.	See LiNX service manual.
	Tyre visibly dented	Not enough tyre pressure	Check tyre pressure, replace inner tube and/or valve if necessary.	
Error message does not disappear	None	Bad connections	Check all connecting cables.	See 6.12.6 Checking Cables, page 64.
		Motor brake defective	Measure internal resistance of brakes, replace motor if defective.	See 5.2 Testing Motor Brake, page 15 and 6.9.1 Replacing Motor-Gearbox Unit, page 38.

Problem	Other symptoms	Possible cause	Solution	Documentation
Motors stop and start again	None	Voltage decline	Stop driving and allow electronics to cool down.	
Motor runs but loses power	None	High motor load allows power module to lower voltage	Stop driving and allow electronics to cool down.	
Motors stop and do not start again	None	High motor load allows power module to lower voltage	Leave mobility device switched on and let power module operate. Charge batteries overnight with electronics turned on.	
	None	Circuit breaker switched off	Check cabling and switch on circuit breaker.	See 6.12.6 <i>Checking Cables</i> , page 64 and user manual.
	None	Motor defective	Measure internal resistance of motor, replace motor if defective.	See 5.1 <i>Testing Motor</i> , page 15 and 6.9.1 <i>Replacing Motor-Gearbox Unit</i> , page 38.
	None	Power module defective	Replace power module	See 6.11.1 <i>Replacing Power Module</i> , page 56.
Motors lose power while driving	None	Bad connections	Turn off electronics, wait 10 seconds, turn on electronics. Check all cabling.	See 6.12.6 <i>Checking Cables</i> , page 64.
Motor judders or runs irregularly, or only one motor runs	None	Clutch(es) defective	Replace clutch.	See 6.9.1 <i>Replacing Motor-Gearbox Unit</i> , page 38.
		Bearing defective	Replace motor.	See 6.9.1 <i>Replacing Motor-Gearbox Unit</i> , page 38.
		Collector defective	Measure internal resistance of motor, replace motor if defective.	See 5.1 <i>Testing Motor</i> , page 15 and 6.9.1 <i>Replacing Motor-Gearbox Unit</i> , page 38.
Motors do not run	None	Bad connections	Check all cabling.	See 6.12.6 <i>Checking Cables</i> , page 64.
		Circuit breaker switched off	Check cabling and switch on circuit breaker.	See 6.12.6 <i>Checking Cables</i> , page 64 and user manual.
		Batteries defective	Replace batteries.	See 6.12 <i>Batteries</i> , page 60.
		Cabling to power module or remote defective	Check cabling.	See 6.12.6 <i>Checking Cables</i> , page 64.
		Power module defective	Replace power module.	See 6.11.1 <i>Replacing Power Module</i> , page 56.
	Corroded contacts	Contacts defective	Check cabling, replace if necessary.	See 6.12.6 <i>Checking Cables</i> , page 64.

Problem	Other symptoms	Possible cause	Solution	Documentation
Motor makes clicking noise	None	Clutch(es) defective	Replace clutch.	See 6.9.1 <i>Replacing Motor-Gearbox Unit</i> , page 38.
		Bearing defective	Replace motor.	See 6.9.1 <i>Replacing Motor-Gearbox Unit</i> , page 38.
		Collector defective	Measure internal resistance of motor, replace motor if defective.	See 5.1 <i>Testing Motor</i> , page 15 and 6.9.1 <i>Replacing Motor-Gearbox Unit</i> , page 38.
Scraping noise or motor blocked	None	Clutch(es) defective	Replace clutch.	See 6.9.3 <i>Replacing motor/gearbox clutch</i> , page 40.
		Bearing defective	Replace motor.	See 6.9.1 <i>Replacing Motor-Gearbox Unit</i> , page 38 and 6.9.3 <i>Replacing motor/gearbox clutch</i> , page 40.
		Gearbox defective	Replace gearbox.	See 6.9.1 <i>Replacing Motor-Gearbox Unit</i> , page 38 and 6.9.3 <i>Replacing motor/gearbox clutch</i> , page 40.
Gearbox makes clicking noise	None	Gearbox defective	Replace gearbox.	See 6.9.1 <i>Replacing Motor-Gearbox Unit</i> , page 38 and 6.9.3 <i>Replacing motor/gearbox clutch</i> , page 40.
		Drive wheel loose	Tighten drive wheel, secure bolts with thread locking adhesive if necessary.	See 6.9.1 <i>Replacing Motor-Gearbox Unit</i> , page 38.
Gearbox loses oil	None	Sealing ring on drive shaft defective	Replace gearbox if sealing ring defective.	See 6.9.1 <i>Replacing Motor-Gearbox Unit</i> , page 38 and 6.9.3 <i>Replacing motor/gearbox clutch</i> , page 40.
Irregular running	None	Drive shaft movable or bent	Check drive shaft, replace gearbox, if defective.	See 6.9.1 <i>Replacing Motor-Gearbox Unit</i> , page 38 and 6.9.3 <i>Replacing motor/gearbox clutch</i> , page 40.
Batteries not being charged	None	Circuit breaker defective	Check circuit breaker.	See 6.12.5 <i>Replacing Circuit Breaker</i> , page 62.
		Cable defective	Check cabling.	See 6.12.6 <i>Checking Cables</i> , page 64.
		Batteries defective	Replace batteries.	See 6.12 <i>Batteries</i> , page 60.
	LEDs flashing on charger	Charger defective	Replace charger.	See charger user manual.

Problem	Other symptoms	Possible cause	Solution	Documentation
Short charging period	None	One of the batteries could be defective	Replace batteries.	See 6.12 Batteries, page 60.
Mobility device runs too slowly	None	Remote defective	Replace remote.	See 6.11.1 Replacing Power Module, page 56.
		Batteries defective	Replace batteries.	See 6.12 Batteries, page 60.

6.5.3 Charging device fault diagnosis

Symptom	Possible cause	Solution
No LEDs illuminating on battery charger	Charging device not connected to mains supply.	Ensure that the battery charger has been plugged in.
	No mains supply	Check the mains supply with a voltmeter.
	Defective mains supply cable.	Check the mains supply cable. Replace damaged cables or send the battery charger to Invacare Service for repair.
	LEDs are burnt out	Send the battery charger to Invacare Service for repair.
	An internal fuse might be burnt out.	Send the battery charger to Invacare Service for repair.
Batteries do not charge	Fuse on mobility device has burnt out.	Check mobility device fuses. See “Main fuse”.
	Battery charger not connected to mobility device.	Ensure that the battery charger has been connected to the mobility device.
	No mains supply	Check the mains supply with a voltmeter.
	Defective mains supply cable.	Check the mains supply cable. Replace damaged cables or send the battery charger to Invacare Service for repair.
	Battery charger could be defective.	Use a battery charger which you know is working properly to charge the batteries. Send the defective battery charger to Invacare Service for repair.
	Battery voltage is too low to operate mobility device.	Replace the batteries. See “Removing batteries”

6.6 Service Plan (Once a Year)



CAUTION!

Risk of injury and damage to property, if maximum speed reduction on wheelchair with lifter does not function correctly

The wheelchair's electronics must reduce the maximum possible speed as soon as the lifter is raised.

- Test the maximum speed reduction for correct function after any maintenance work or modifications to the wheelchair.

Component	Check	Remedy	Notes	✓
Posture belt	Damage to posture belt	Replace belt if damaged	See <i>Replacing Posture Belt</i> in service manual of seating system.	
	Belt lock function	Replace belt if damaged	See <i>Replacing Posture Belt</i> in service manual of seating system.	

Component	Check	Remedy	Notes	✓
Armrests	Damage to armrests	Replace cover if damaged		
	Armrest fixings	Tighten screws		
Clothing guard	Damage to clothing guard	Replace clothing guard, if damaged		
	Clothing guard fixings	Tighten screws		
Powered tilt	Tight fit of SL retainer clip	Replace SL retainer clip, if necessary		
Powered recline (if fitted)	Damage to backrest Seams Fixing Check cable Check function	Replace parts if damaged Tighten screws Replace cable or motor if necessary		
Frames (chassis) / battery mounting	Check fixings, welded seams and battery mounting	Tighten screws Replace components if necessary		
Dahl Docking station	Check screws	Tighten screws	See 7 Mounting Dahl Docking System, page 70.	
Wheel suspension and wheels	Check drive wheels for tight fit and side play	Adjust, replace wheel hubs	See 6.10 Wheels, page 44.	
	Check castors for tight fit, float and side play	Replace wheels, castor forks or wheel bearings	See 6.10 Wheels, page 44.	
	Tyres	Repair or replace if damaged	See 6.10 Wheels, page 44.	
	Check suspension	Repair or replace if damaged	See 6.10 Wheels, page 44.	
	Check straight running	Replace wheels, castor forks or wheel bearings	See 6.10 Wheels, page 44.	
Drive units, clutch mechanism	Motors	Test motors	See 5.1 Testing Motor, page 15.	
	Check functions in drive and push modes Check clutch mechanism	Check carbon brushes, replace if necessary (not with lifetime brushes) Replace motor if necessary Tighten screws/nuts, adjust or replace if necessary	See 6.9 Drive Components, page 38.	
Brakes	Check motor brake	Test motor brake	See 5.2 Testing Motor Brake, page 15.	
Legrests	Check welded seams, interlocking, screws, foot plates	Tighten, replace if necessary		
Power legrests (if fitted)	Check cable Check contacts Check functions	Replace cable if necessary		
Lighting (if fitted)	Check cable Check function	Replace lamp or cable if necessary	See 6.13 Lighting unit, page 65.	

Component	Check	Remedy	Notes	✓
Battery mounting	Check battery support and mounting belts for damage	Replace if necessary		
Batteries	Check batteries for damage	Replace batteries if necessary	See 6.12 Batteries, page 60.	
	Check battery voltage	Charge batteries	See user manual.	
	Check contacts and terminals	Clean contacts and terminals	See 6.12 Batteries, page 60.	
Remote / power module	Remote, status LED flashing	Evaluate error/flash code	See 6.5 Troubleshooting, page 19.	
	Fixings	Tighten fixings, replace if necessary		
	Cables and connecting plugs	Replace damaged cables and tighten connecting plugs, if necessary		
	Joystick function	Replace joystick knob if necessary		
		Replace remote if necessary		
Power supply	Replace damaged cables and tighten connecting plugs, if necessary			
Chair configuration	Check chair configuration version	Update software if newer version available	See LiNX service manual.	
Screws (every 6 months)	Check screws for tight fit	Tighten screws if necessary		

6.7 Shrouds

6.7.1 Power Module Shrouds

Removing Right-Hand Shroud

1. Loosen hand screws Ⓐ on right-hand side.
2. Swivel shroud Ⓑ forwards. Remove shroud sideways.

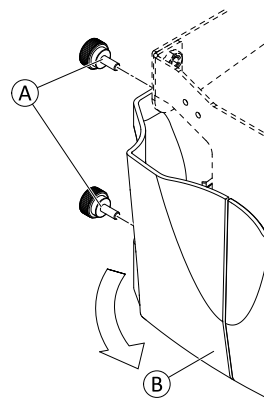

Fig. 6-1

Removing Left-Hand Shroud



- 4 mm Allen key

1. Remove right-hand shroud.
2. Loosen screws ④ on left-hand side.
3. Remove shroud ③ forwards.

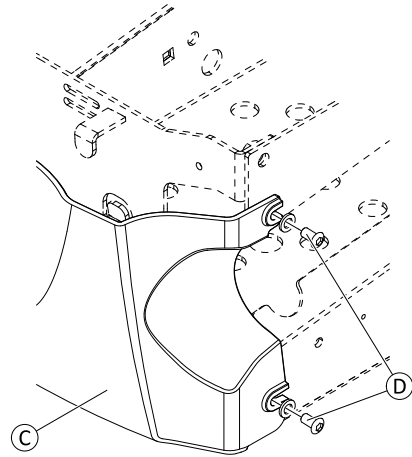

Fig. 6-2

Installing Shrouds

1. Install parts in reverse order. Tighten screws to 3 Nm.
2. Test all functions.

6.7.2 Water Protection Shroud



- 4 mm Allen key
- 13 mm wrench
- 19 mm wrench
- Oblong wooden block (at least 14 x 14 x 30 cm)

1. Place wooden block underneath mobility device and prop up mobility device.
2. Remove both power module shrouds. See 6.7.1 *Power Module Shrouds*, page 24.
3. Unplug motor cable.
4. Remove drive wheel. See 6.10.6 *Replacing Drive Wheel (5-Screw Installation)*, page 48.
5. Remove motor-gearbox unit. See 6.9.1 *Replacing Motor-Gearbox Unit*, page 38.
6. Remove motor cable ⑥ forwards from cutout.
7. Position motor cable at point ③.
8. Move shroud ④ carefully forwards. Pay attention that snap hooks ① at top and bottom do not break.
9. Replace shroud.

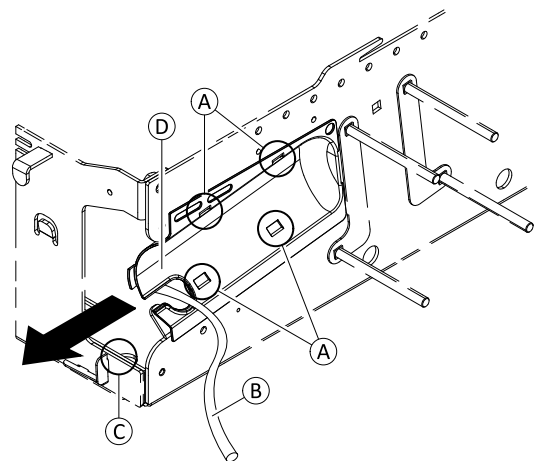

Fig. 6-3

10. Install parts in reverse order.
11. Test all functions.

6.7.3 Main Frame Shrouds



- 4 mm Allen key

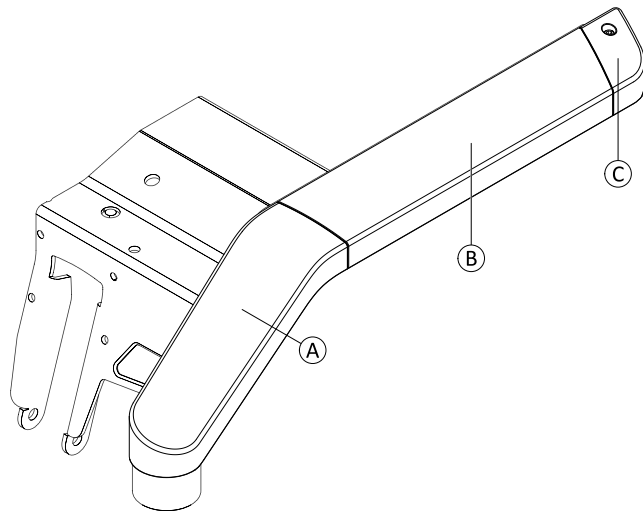

Fig. 6-4 Parts of main frame shrouds

Ⓐ	Front shroud
Ⓑ	Middle shroud
Ⓒ	Rear Shroud

Removing Front Shroud

1. Loosen and remove hand screw Ⓓ on bottom side of frame.
2. Pull shroud Ⓐ upwards. Remove shroud.

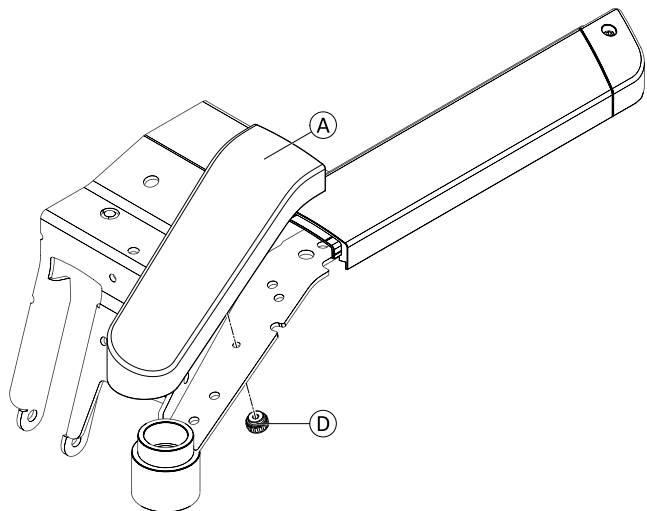

Fig. 6-5

Removing Middle Shroud

1. Remove front shroud (A) and rear shroud (C).
2. Remove shroud (B).

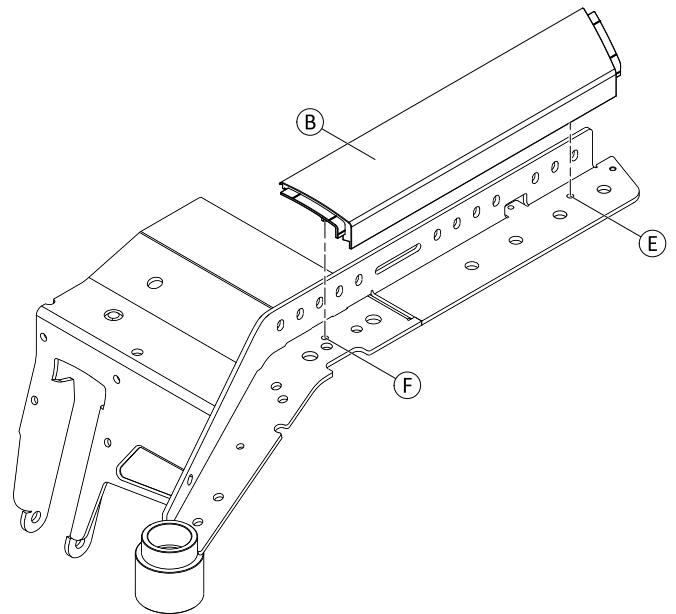

Fig. 6-6

Removing Rear Shroud

1. Loosen and remove screw (G).
2. Remove shroud (C).

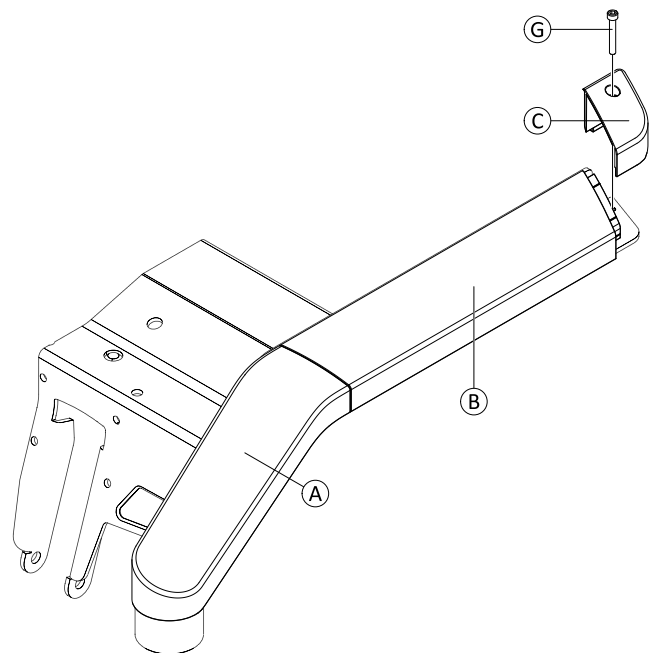

Fig. 6-7

Installing Shrouds

1. Install middle shroud. Make sure to install pins on rear side within corresponding holes (E) and (F).
2. Install remaining parts in reverse order.
3. Test all functions.

6.7.4 Battery Shroud



- 4 mm Allen key
- Tie wrap
- Oblique pliers

1. Remove rear shroud. See 6.7.5 Rear Shroud, page 28.
 2.
 -  Take note of positions of cables and sockets. Mark plugs and sockets or take a photo with digital camera.
- Unplug all cables between chassis and seating system.
3. Secure all cables using tie wrap.
 4. Pull shroud (A) slightly backwards.
 5. Swivel shroud slightly to the left.
 6. Place cables on top of battery box.
 7. Remove shroud backwards.

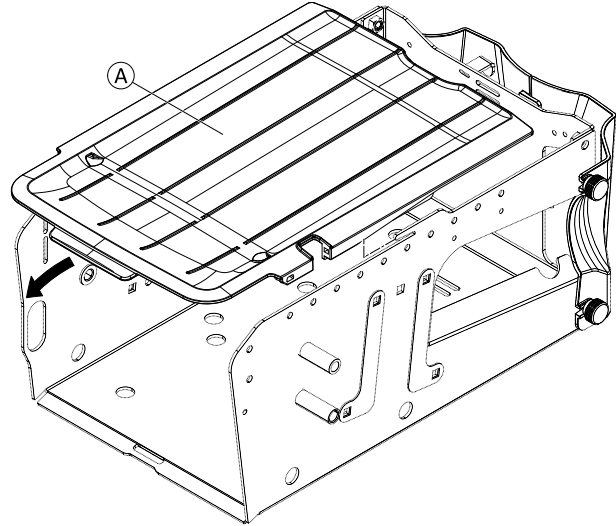





Fig. 6-8

8.
 -  In some cases it may be necessary to remove tie wrap before installing cables to notch.
- Install parts in reverse order. Make sure that cables are correctly installed to notch of shroud.
9. Remove tie wrap.
 10. Plug in all cables.
 11. Test all functions.

6.7.5 Rear Shroud

 It is not possible to retrofit options such as light or operation hour counter to an existing shroud. Replace the shroud instead.

Removing Shroud

-  • 4 mm Allen key

1. Loosen and remove screws (C) including washers (B) on both sides.
2. Loosen shroud (A) carefully.
3. If fitted, unplug all cables.
- 4.

 Take note of positions of labels. Take a photo with digital camera.

Remove shroud.

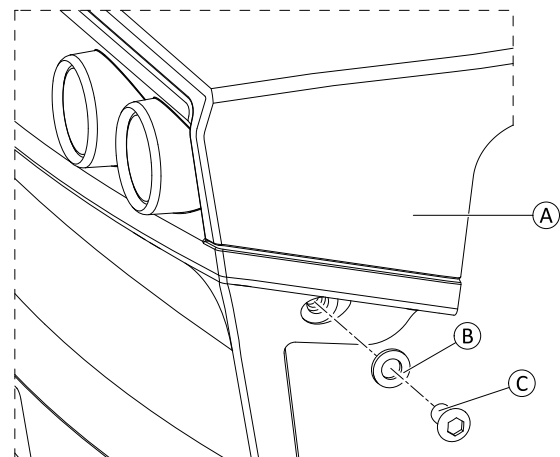

Fig. 6-9

Separating Parts



- Plastic fastener removing tool (or similar)

1. Loosen and remove clips **D** on both sides.
2. Swivel top shroud **E** and separate it from bottom shroud **F**.

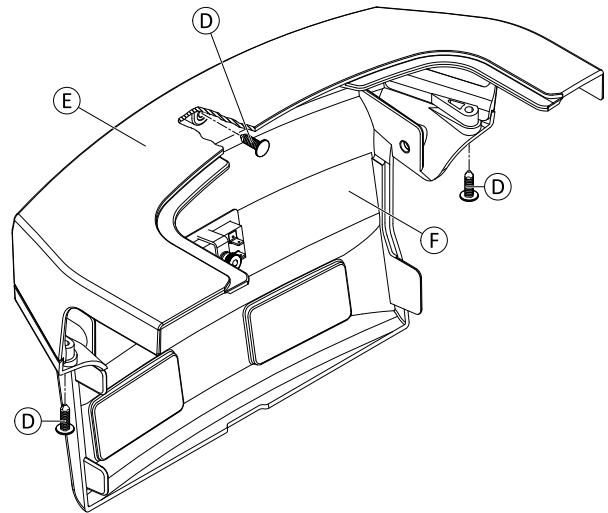

Fig. 6-10

Installing Shroud

1. Install parts in reverse order.
2. Install labels.
3. Test all functions.

6.7.6 Replacing Fender

1. Press in snap-in element on inner side of fender **A** and pull fender upwards. Remove fender.
2. Replace fender mount, if necessary. See 6.9.1 *Replacing Motor-Gearbox Unit*, page 38.
3. Install parts in reverse order. Push fender downwards, until fender snaps to fender mount.
4. Test all functions.

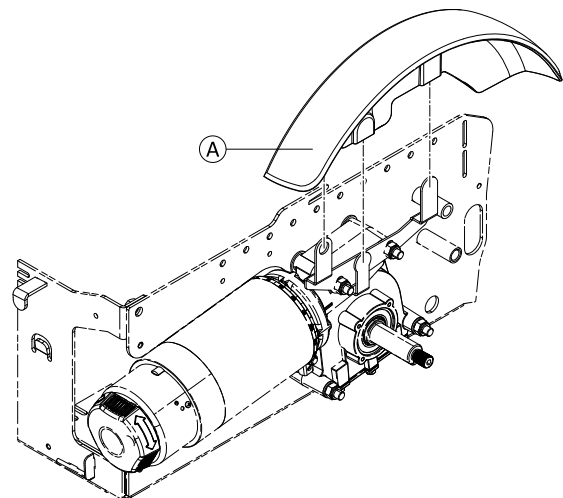

Fig. 6-11

6.7.7 Replacing Front Fender on Single-Sided Fork

Removing Fender

1. Slightly press both hooks (A) together.
2. Remove fender (B) backwards out of fork (C).

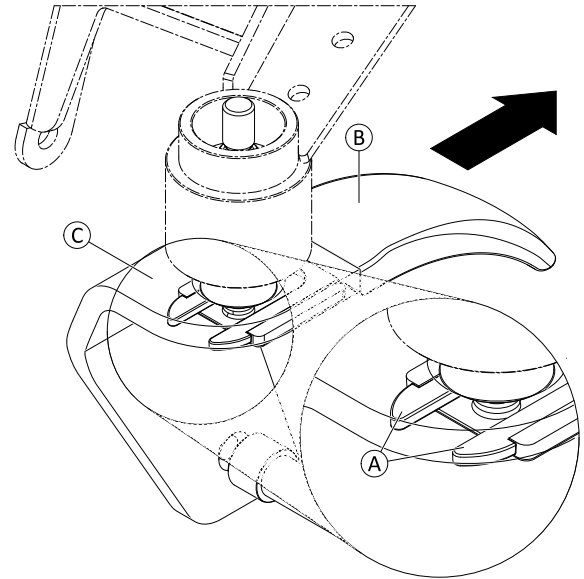

Fig. 6-12

Replacing Bracket



CAUTION!

Risk of Crushing to Hands and Feet by Weight of Mobility Device

- Pay attention to hand and feet.
- Use proper lifting techniques.



CAUTION!

Risk of Uncontrolled Movement of Mobility Device

- Turn off power supply (ON/OFF key).
- Engage drive.
- Before raising mobility device, secure wheels by blocking them with wedges.
- Prevent the mobility device tipping by propping it up on a wooden block which is long and wide enough under the battery case. If the wooden block is too short or too high, the mobility device can still tip.



- TX30 Torx key
- Oblong wooden block (at least 14 x 14 x 30 cm)

1. Remove fender.
2. Place wooden block underneath mobility device and prop up mobility device.
3. Remove wheel. See 6.10.8 *Replacing Castor Wheels on Single-Sided Fork*, page 51.
4. Loosen and remove screw (F), washer (D) and bracket (E).

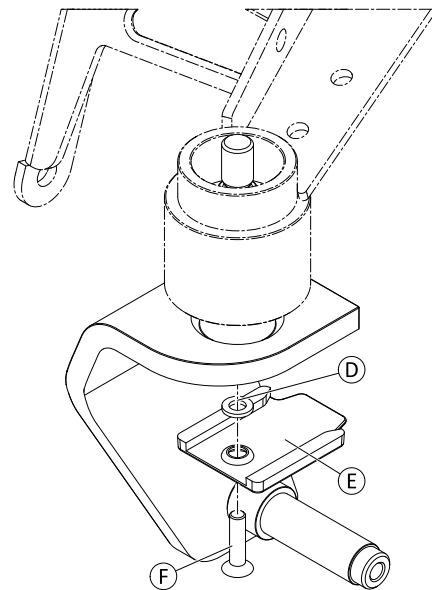

Fig. 6-13

Installing Fender

1. Install parts in reverse order.
2. Test all functions.

6.7.8 Replacing Front Fender on Double-Sided Fork



CAUTION!

Risk of Crushing to Hands and Feet by Weight of Mobility Device

- Pay attention to hand and feet.
- Use proper lifting techniques.



CAUTION!

Risk of Uncontrolled Movement of Mobility Device

- Turn off power supply (ON/OFF key).
- Engage drive.
- Before raising mobility device, secure wheels by blocking them with wedges.
- Prevent the mobility device tipping by propping it up on a wooden block which is long and wide enough under the battery case. If the wooden block is too short or too high, the mobility device can still tip.



- TX40 Torx key
- Oblong wooden block (at least 14 x 14 x 30 cm)

1. Place wooden block underneath mobility device and prop up mobility device.
2. Remove wheel. See 6.10.7 *Replacing Castor Wheel on Double-Sided Fork*, page 49
3. Slightly push on fender **B** at point **A** and swivel fender downwards.
4. Remove fender **B** backwards out of fork **C**.

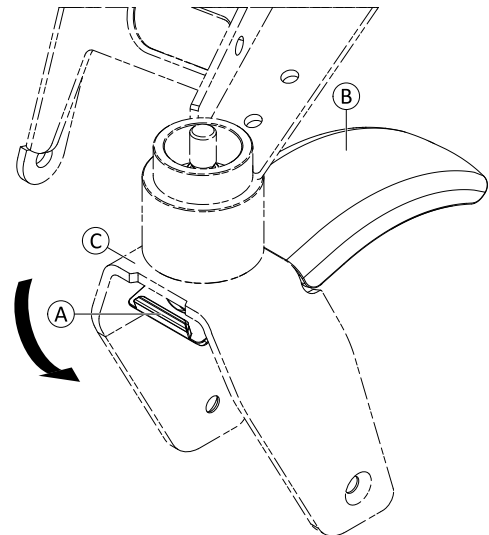

Fig. 6-14

5. Install parts in reverse order.
6. Test all functions.

6.7.9 Replacing Rim Cap and Insert (Drive Wheel)



- Flat screwdriver

1. Insert tip of screwdriver between cap © and insert ®.
2. Remove insert.
3. Insert tip of screwdriver between rim and cap at fulcrum ☉.
4. Loosen and remove cap.
5. Replace defective parts.
6. Hold cap over rim.
7. Carefully push cap into rim.
8. Hold insert over cap.
9. Carefully push to fasten insert, until foot of insert Ⓐ snaps and insert ® clings to cap.

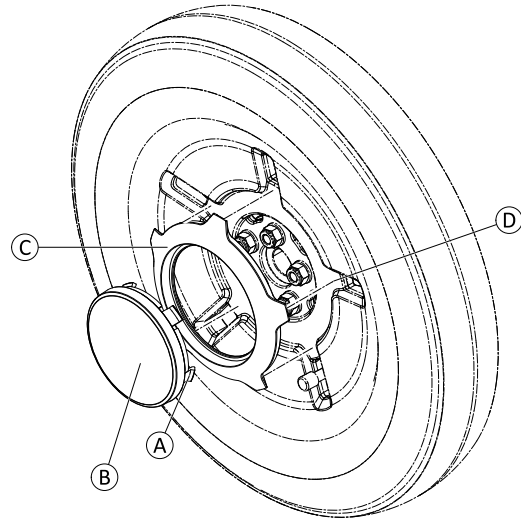

Fig. 6-15

6.7.10 Replacing Rim Cap (Castor Wheel)

- !** **Risk of Damage to Rim Caps.**
 Incorrect installation of rim cap can lead to damage on rim cap itself or loosening of rim cap.
- Install rim cap with notch positioned at valve.
 - Position cap straight on rim and carefully push on outer edges for initial fixation.
 - Ensure not to damage fixation pins on rear side while installing to rim.



- Flat screwdriver

1. Remove wheel from fork.
2. Insert tip of screwdriver between rim and cap at fulcrum ☉.
3. Loosen and remove cap.
4. Replace defective parts.
5. Position cap over rim.
6. Carefully push cap into rim.
7. Re-install wheel to fork.

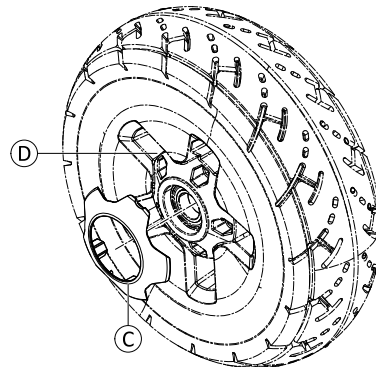

Fig. 6-16

6.8 Chassis

6.8.1 Changing Wheelbase

- i** Changing the wheelbase influences the seat depth and the centre of gravity of the mobility device. See 4.2.3 *Adjusting Centre of Gravity of Seat, page 9*. You may need to adjust seat depth or position of modules to meet requirements of the user.

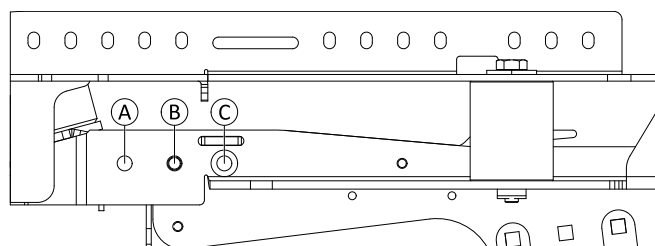



Fig. 6-17

Wheelbase	Recommended Seat Depth ¹	Narrow Base	Wide Base
460 mm	405 mm -- 455 mm	Ⓐ	N/A
490 mm	455 mm -- 480 mm	Ⓑ	Ⓐ
520 mm	480 mm -- 505 mm	Ⓒ	Ⓑ
550 mm	505 mm -- 580 mm	N/A	Ⓒ

 If the wheelbase length is changed to or from its longest variant, the folded sheet on anti-tipper unit must be replaced (see spare parts catalogue).



- 5 mm Allen key
- 6 mm Allen key
- Oblong wooden block (at least 7 cm x 7 cm x 30 cm)

1. Place wooden block underneath mobility device next to power module and prop up mobility device.
2. Remove batteries. See 6.12 *Batteries*, page 60.
3. Loosen and remove screws ① and wedge lock washers ② on both sides.
4. Loosen and remove all screws ③ on both sides.
5. Loosen and remove screw ④ and washer ⑤ on both sides.
6. Move main frame ⑥ to desired position (Ⓐ, Ⓑ or Ⓒ).

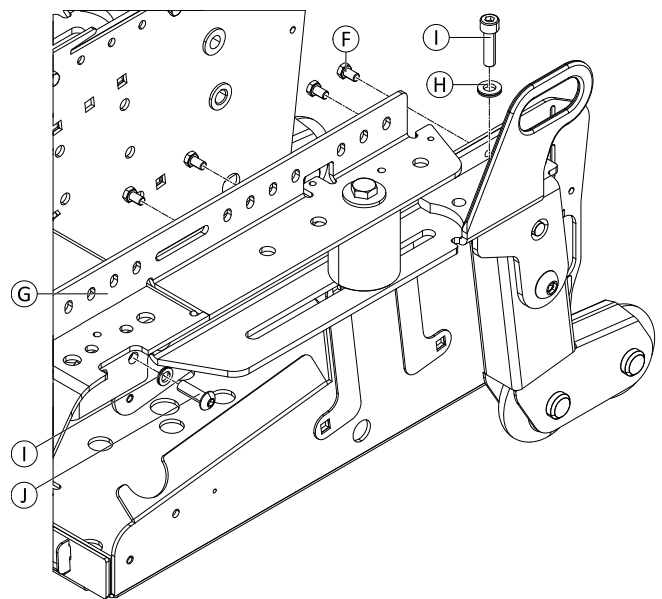

Fig. 6-18

7. If necessary, replace folded sheet. See 6.10.12 *Replacing Anti-Tipper Unit*, page 55.
8. Install parts in reverse order.
9. Adjust seat depth to meet requirements of user. See user manual.
10. Test all functions.

6.8.2 Replacing Kerb Climber



CAUTION!

Risk of crushing

Injury hazard to hands. The gas spring is under pressure.

- Be careful with your hands.
- Use suitable tools.



- 5 mm Allen key
- 10 mm wrench



When removing, take care of small parts such as screws and washers. Put all small parts down so that they can be installed in correct sequence.

1. Standard values. Individual values depend on configuration of seating system.

1. Hold in place nut (A) on rear side of main frame. Loosen and remove bolt (C), washers (B) and nut (A).
2. Repeat previous step for remaining screwed connections.
3. Remove bracket (D) including kerb climber.

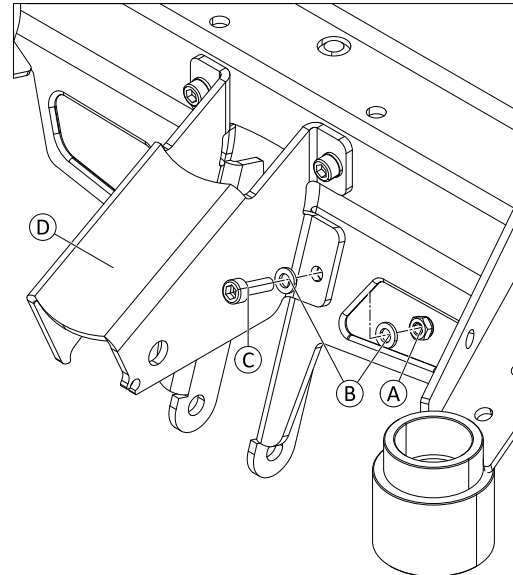
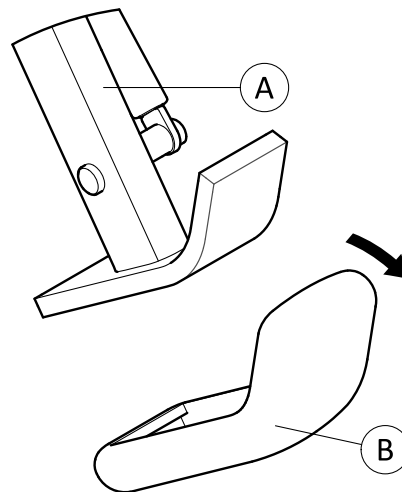

Fig. 6-19 For better view only the bracket is shown.

4. Install parts in reverse order.
5. Test all functions.



6.8.3 Replacing Rubber Foot



1. Pull front part of old rubber foot (B) off kerb climber (A) in forward direction.
2. Place rear part of new rubber foot over kerb climber.
3. Push front part of new rubber foot over kerb climber.

6.8.4 Replacing Tie-Down Points

The mobility device can be fitted with two additional tie-down points for easier access. If these points are retrofitted, the existing tie-down points on the front of the main frame must not be used anymore.

-
-  • 5 mm Allen key
 -  • 13 mm wrench
-

1. Remove main frame shrouds. See 6.7 Shrouds, page 24.
2. Loosen and remove nuts ④.
3. Remove tie-down point ③.
4. Remove bolts ① and washers ②.

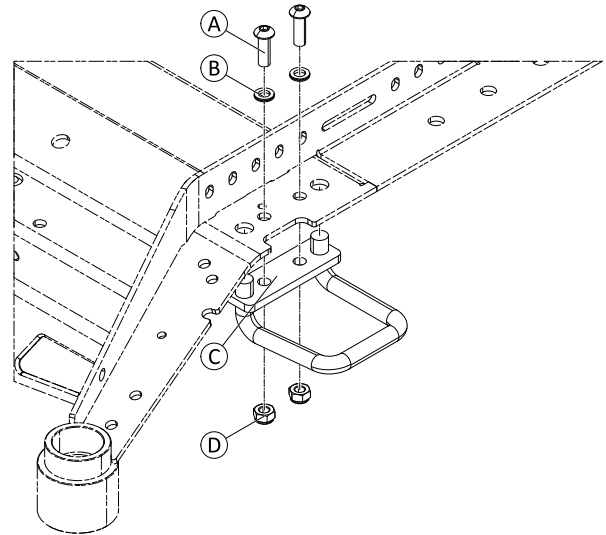

Fig. 6-20

5. Install parts in reverse order.
6. Test all functions.

6.8.5 Replacing C.T.C. Suspension



- 8 mm Allen key
- 17 mm wrench
- 19 mm open-ended wrench
- Oblong wooden blocks (at least 7.5 cm x 7.5 cm x 30 cm)

Removing Main Frame

1. Place wooden block underneath mobility device and prop up mobility device.
2. Remove seat.
3. Loosen and remove screws ① and washers ② of rear suspension on both sides.
4. Loosen and remove screw ④, rebound ③ and washer ⑤ of C.T.C. suspension.
5. Remove main frame ⑥ upwards.

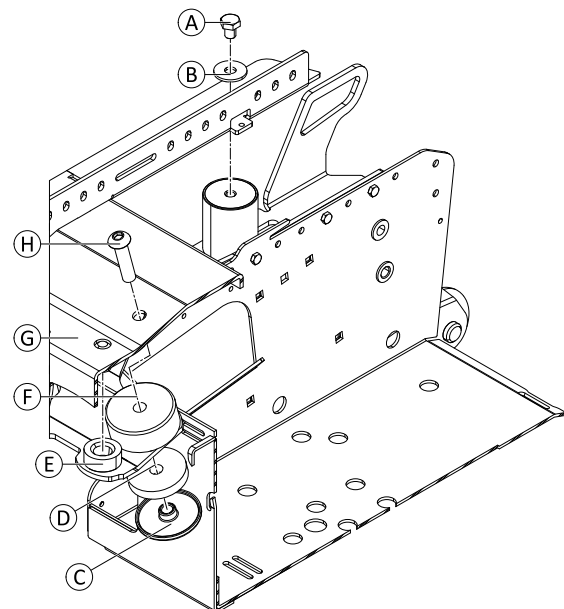

Fig. 6-21 For better view battery box and main frame are shown partially only.

Replacing Shock Absorber / Bearing

1. Replace shock absorber ⑥ and bearing ⑤.

Installing Main Frame

1. Install parts in reverse order. Tighten screw ⑥ to 20 Nm and screw ⑤ to 17 Nm.
2. Adjust limit stopper. See below.
3. Test all functions.

Adjusting Limit Stopper

-
-  • 13 mm wrench
• Feeler gauge with 0.5 mm
-

1. Ensure that mobility device is contacting floor with all its wheels and casters.
2. Loosen nut (not shown).
3. Rotate stopper ① until there is a space of 0.5 mm between it and main frame.
4. Tighten nut to 10 Nm.
5. Repeat for other stopper.

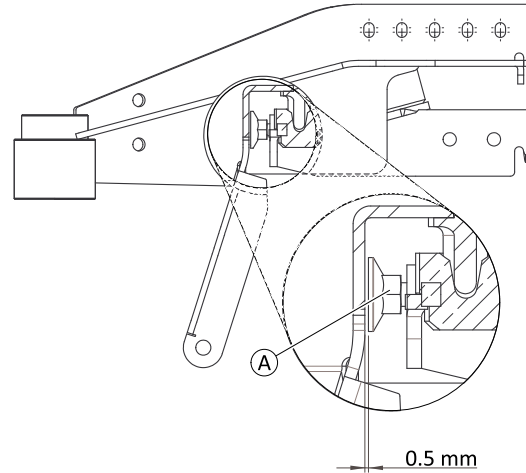



Fig. 6-22

6.8.6 Replacing and Adjusting Rear Suspension

Replacing Suspension

-
-  • 8 mm Allen key
• 17 mm wrench
• 19 mm wrench
• Water pump pliers
• Oblong wooden block (at least 7 cm x 7 cm x 30 cm)
• 2 wooden blocks (at least 4 cm x 4 cm x 8 cm)
-

1. Place wooden block underneath mobility device and prop up mobility device.
2. Loosen screw of C.T.C. suspension. Do not remove screw. See 6.8.5 Replacing C.T.C. Suspension, page 35
3. Loosen and remove screw (E) and washer (F) on both sides.
4. Tilt seat including main frame (I) forwards. Place wooden blocks between carrier (J) and main frame (I) on both sides.
5. Loosen and remove suspension (G) and T-nut (H).
6. Replace suspension.

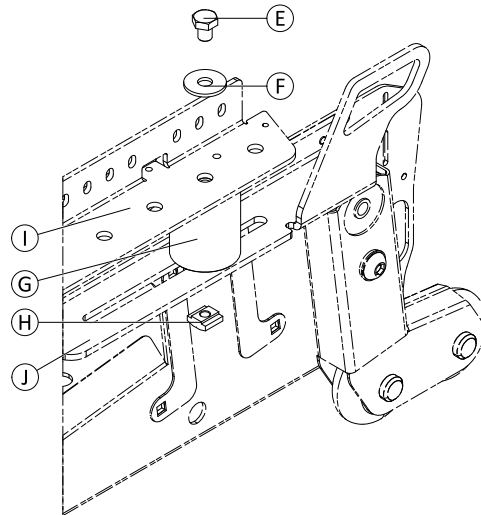

Fig. 6-23

7. Adjust position of suspension. See below.
8. Install screws (E) and washers (F). Tighten screw to 17 Nm.
9. Tighten screw of C.T.C. suspension to 20 Nm.
10. Test all functions.

Adjusting Suspension



- 17 mm wrench
- Water pump pliers
- Oblong wooden blocks (at least 7 cm x 7 cm x 30 cm)
- Wooden block (at least 4 cm x 4 cm x 8 cm)

Recommended User Weight	Position
up to 70 kg	(A)
up to 110 kg	(C)
up to 136 kg	(D)
up to 160 kg	(A) and (D)

1. Loosen screw of C.T.C. suspension. Do not remove screw. See 6.8.5 Replacing C.T.C. Suspension, page 35.
2. Loosen and remove screw (E) and washer (F).
3. Tilt seat including main frame (I) forwards. Place wooden block between carrier (J) and main frame (I).
4. Loosen suspension (G).
5. Move suspension to desired position (A), (C) or (D) according to table. If required, install additional suspension.
6. Re-tighten suspension.
7. Install screw and washer. Tighten screw to 17 Nm.
8. Repeat previous steps for second suspension.
9. Tighten screw of C.T.C. suspension to 20 Nm.
10. Test all functions.

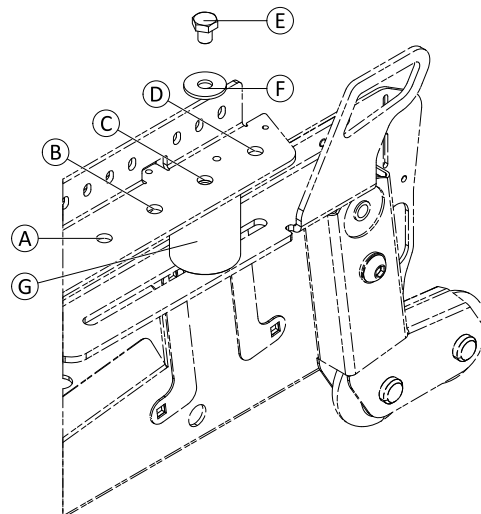

Fig. 6-24

6.9 Drive Components

6.9.1 Replacing Motor-Gearbox Unit

-  • 13 mm wrench
-  • 19 mm wrench
- Oblong wooden blocks (at least 14 x 14 x 30 cm)

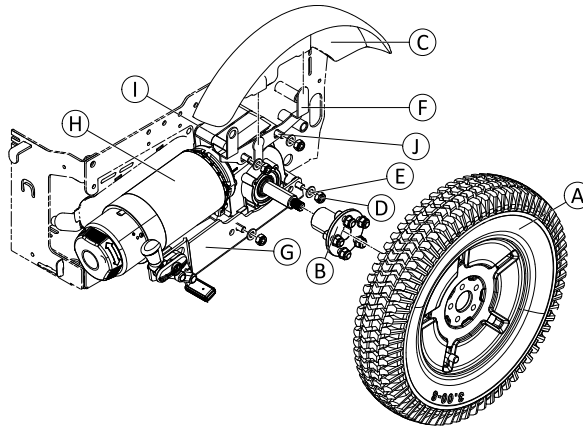

Fig. 6-25

	Component	Comments
Ⓐ	Wheel	
Ⓑ	Wheel hub	
Ⓒ	Fender	
Ⓓ	Nut	
Ⓔ	Washer	
Ⓕ	Fender mount	
Ⓖ	Wheel lock mount	
Ⓗ	Motor-gearbox unit	
Ⓘ	Width adapter	Optional component.
Ⓙ	Bolts	Available in two different lengths. If a width adapter is retrofitted, the bolts must be replaced.

Removing Unit

1. Turn off electronics.
2. Unplug motor cable at power module.
3. Remove wheel including wheel hub.
4. Remove fender. See 6.7.6 *Replacing Fender*, page 29.

5. Loosen and remove nuts ④ and washers ⑤.
6. If fitted, remove mounts for wheel lock ⑥ and fender ⑦.
7. Pull off unit ⑧ of bolts ⑩.

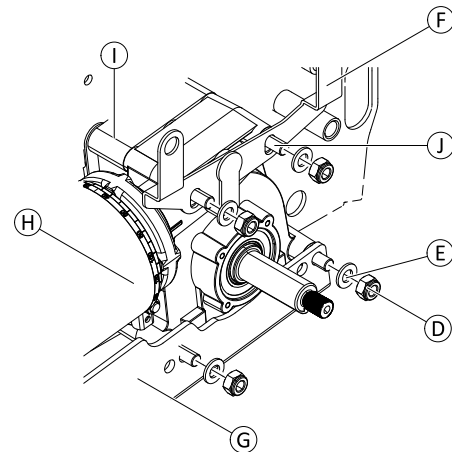

Fig. 6-26

8. If fitted, remove adapter ①.

Installing Unit

1. Check that sealing ring and unit are correctly mounted. Nut must be located on the outside and rotation of motors must follow the specifications.
2. Install parts in reverse order.
3. Plug in motor cable to power module.
4. Perform calibration process. See in LiNX service manual.
5. Test all functions.

6.9.2 Replacing or rotating motor/gearbox unit sealing ring



CAUTION!

Risk of crushing

The motor / gearbox unit is very heavy. Risk of injury to hands.
– Pay attention to heavy weight.



- 6 mm Allen key
- 5/8" Allen key
- 7/8" Allen key
- 5/16" Allen key
- Phillips screwdriver size 2
- 10 mm socket wrench
- 1/2" socket wrench
- 1/4" socket wrench
- 5/16" socket wrench
- Torque wrench 0 - 25 Nm (or similar)
- Torque wrench 10 - 80 Nm (or similar)
- Two long wooden blocks, min. 14 x 14 x 30 cm

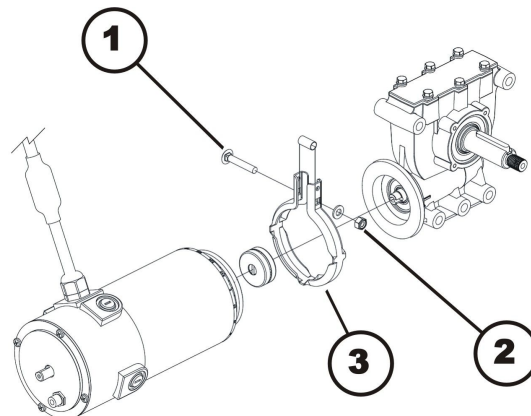

Removing sealing ring

1. Remove motor/gearbox unit, as described in chapter 8.14.2.
2. Use wrench to loosen and remove nut (2) including washer.
3. Remove screw (2), which secures sealing ring (3).
4. Carefully bend sealing ring apart and remove it.

Installing sealing ring

1. Install sealing ring so square hole for carriage screw is on inside of mobility device.
2. Insert carriage screw through sealing ring.
3. Install washer and self-locking nut.
4. Do not tighten nut completely, as motor orientation must be adjusted during installation.

6.9.3 Replacing motor/gearbox clutch



CAUTION!

Risk of crushing

Motor / gearbox unit is very heavy. Risk of injury to hands.
– Pay attention to heavy weight.



- 5/8" Allen key
- 7/8" Allen key
- 5/16" Allen key
- 6 mm Allen key
- Phillips screwdriver size 2
- 10 mm wrench
- 1/2" wrench
- 1/4" wrench
- 5/16" wrench
- Torque wrench 0 - 20 Nm (or similar)
- Torque wrench 5 - 25 Nm (or similar)
- Torque wrench 10 - 80 Nm (or similar)
- Two long wooden blocks, min. 14 x 14 x 30 cm

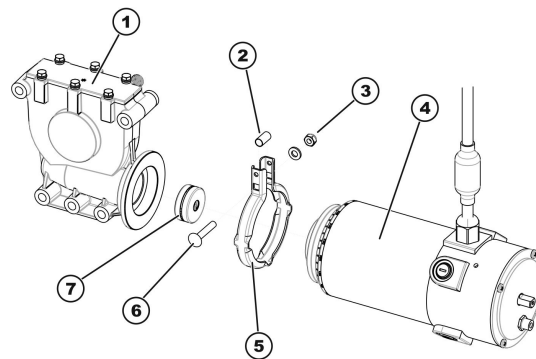

Removing motor/gearbox clutch

1. Removing motor/gearbox unit, as described in *Replacing Motor/Gearbox Unit*.
2. Loosen and remove self-securing nut (3).
3. Remove carriage screw (6), which secures sealing ring (5).
4. Carefully bend sealing ring apart and remove it.
5. Pull motor (4) and gearbox unit (1) carefully apart.
6. Remove clutch individual parts (7).
7. Replace clutch, if necessary.

Installing motor/gearbox clutch

1. Install new clutch (7) on motor axle. Pay attention to position of groove.
2. Position locking ring (5) on motor (4) or gearbox (1).
3. Carefully insert motor into gearbox. Pay attention to position of groove in axle of gearbox. If necessary, rotate motor and gearbox to correct position.
4. Insert carriage bolt through locking ring. Do not forget spacer sleeve (2).
5. Install washer and self-locking nut.
6. Do not tighten self-locking nut completely, as motor orientation must be adjusted during installation.
7. Install motor/gearbox unit, as described in *Replacing Motor/Gearbox Unit*.

6.9.4 Replacing Engaging Turn Knob



When replacing the engaging turn knob, you must ensure that the correct fitting position is used during assembly.



- 3 mm Allen key

1.

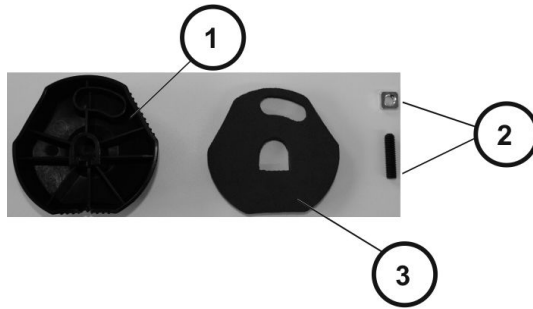

Fig. 6-27

Screw shim onto grub screw.

2. Place screw joint in engaging turn knob (rear side (1)).

3.

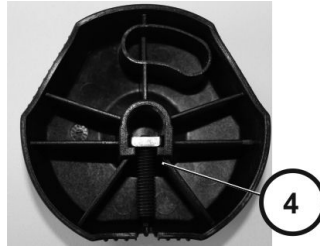

Fig. 6-28

Check that screw joint (4) is positioned precisely in engaging turn knob.

4. Place nonwoven fabric (3) in engaging turn knob (rear side (1)).

5.

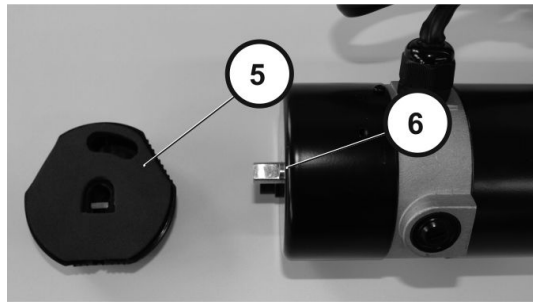

Fig. 6-29

When installing engaging turn knob (5) make sure that position (6) is correct.

6.

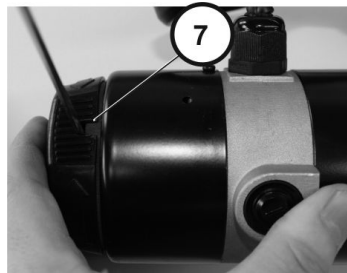

Fig. 6-30

Tighten bolt (7).

7.

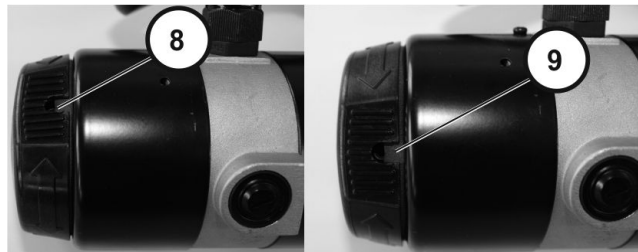



Fig. 6-31

Check that engaging turn knob can be turned to "push" position (clockwise) and "drive" position (counterclockwise).

6.9.5 Replacing Castor Fork

Various forks can be installed to the mobility device. The following instructions show a single-sided fork as an example. The course of action is the same for other variants.

-  • 19 mm wrench
 • Torque wrench
 • Oblong wooden block (at least 14 cm x 14 cm x 30 cm)
 • Parallel pin punches (6/8)
 • Hammer (300 g - 500 g)

Removing:

1. Place wooden block underneath mobility device and prop up mobility device.
2. Remove front part of main frame shrouds. See 6.7.3 *Main Frame Shrouds, page 25*.
3. Loosen and remove nut **A** including washer **B**.
4. Remove fork **E** downwards.
5. If necessary, remove ball-bearings **C** and **D**.
If needed, use hammer and parallel pin punch to drive bearing out of housing. Hit outer ring of bearing.

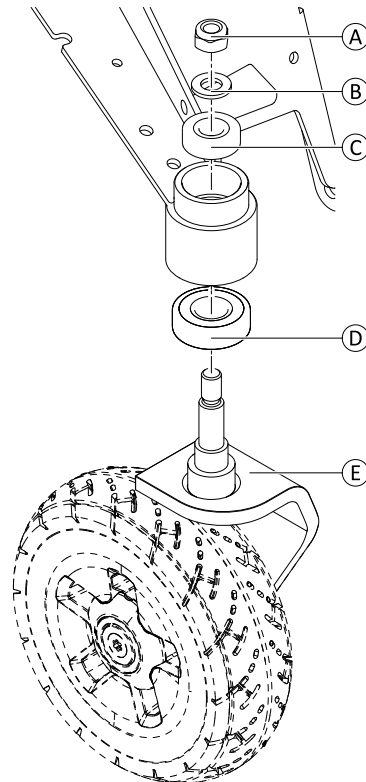

Fig. 6-32

Installing:



CAUTION!

Incorrect reassembly can damage bearings and cause castors to come off

Single-row angular ball bearing rings are not identical on both sides. There is only one correct way to insert them.

- Bearings must always be installed so that narrow borders of the ball bearings are facing each other (inside).
- Steering head bolts and nuts must always be pressing against wide (outside) border of ball bearings. Otherwise, bearings will be pressed apart and damaged by bolts.

The illustrations show the wide border of the ball bearing on the outside of the ball race **A** and the narrow ball bearing edge on the inside **B**.



Fig. 6-33



Fig. 6-34

1. Install parts in reverse order. Tighten nut ① to 14 ± 1 Nm.
2. Check all moveable parts for ease of movement. After installation, castor should rotate freely but bearings should have no play.
3. Re-install shroud.
4. Test all functions.

6.9.6 Replacing Castor Lock

Replacing Locking Device



- 6 mm Allen key

1. Unlock castor lock ③.
2. Remove front part of main frame shrouds. See 6.7.3 *Main Frame Shrouds, page 25*.
3. Loosen and remove screw ①, washer ② and locking device ③.

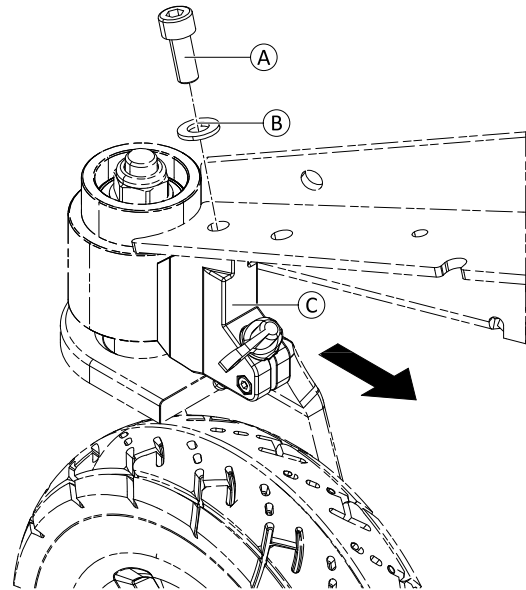

Fig. 6-35

4. Install parts in reverse order. Make sure to install screw including washer to correct mounting hole of locking device.
5. Test all functions.

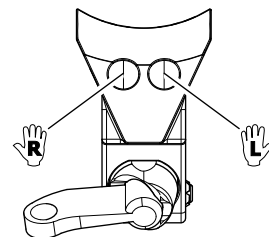

Fig. 6-36

Replacing Locking Plate on Single-Sided Forks



- 4 mm Allen key
- 5 mm Allen key

1. Place wooden block underneath mobility device and prop up mobility device.
2. Remove wheel.
3. Loosen and remove screw (B) and locking plate (A).
4. Install parts reverse order.
5. Test all functions.

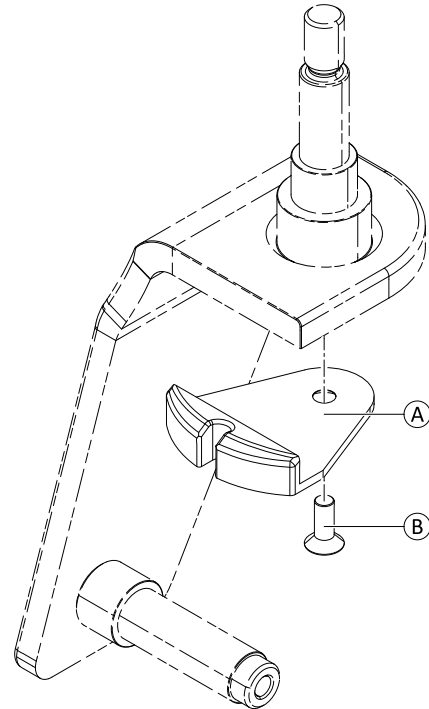

Fig. 6-37

Replacing Locking Plate on Double-Sided Forks

This component is not serviceable. Replace the fork instead.

6.10 Wheels

6.10.1 Repair Instructions

- i Important information about maintenance work tools!**
- Some maintenance work which is described in this manual and can be carried out by the user without problems require the correct tools for proper work. If you do not have the correct tool available we do not recommend that you try to carry out the relevant work. In this case, we urgently recommend that you contact an authorised specialist workshop.

The following are instructions on maintenance and repairs that can be performed by the user. For the specifications of spare parts please see *Technical Data*, or consult the service manual, available from Invacare (in this connection please see the addresses and phone numbers at the end of this user manual). In case you require assistance, please contact your Invacare dealer.



CAUTION!

Risk of damage or injury if the mobility device is accidentally set into motion during repairs

- Switch the power off (ON/OFF Button).
- Engage the motors.
- Secure the mobility device against rolling away by placing wedges under the wheels.



CAUTION!

Risk of hands and feet being crushed by the weight of the wheelchair

- Pay attention to your hands and feet.
- Use the correct lifting techniques.

6.10.2 Tyre Pressure



CAUTION!

Risk of damage to rim and tyre when tyre pressure is exceeded

- Observe recommended tyre pressure.

For recommended tyre pressure see inscription on tyre, rim, or contact Invacare. Compare table below for conversion.

psi	bar
22	1.5
23	1.6
25	1.7
26	1.8
28	1.9
29	2.0
30	2.1
32	2.2
33	2.3
35	2.4
36	2.5
38	2.6
39	2.7
41	2.8
42	2.9
44	3.0

6.10.3 Tyre Types

There are three different types of tyres or inner tubes, and specific points must be observed for the replacement of each type. The individual types of tyres can be easily distinguished:

- Pneumatic tyres have black valve caps.
- Puncture-protected tyres have red valve caps.
- Puncture-proof tyres have no valves.







There are five chapters about tyre repair and wheel replacement:

- *6.10.6 Replacing Drive Wheel (5-Screw Installation), page 48*
- *Replacing Drive Wheel (1-Bolt Installation)*
- *6.10.7 Replacing Castor Wheel on Double-Sided Fork, page 49*
- *6.10.8 Replacing Castor Wheels on Single-Sided Fork, page 51*
- *6.10.9 Replacing Tyres, page 52* deals with tube repair and replacing solid tyres.

 Not all chapters are necessarily contained in this manual.

 Specific tightening torques for wheels and rim halves are listed in *6.10.4 Specific Tightening Torques, page 45*.

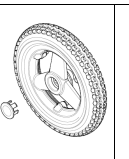
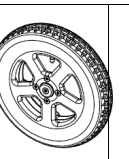
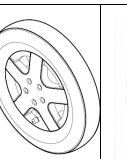
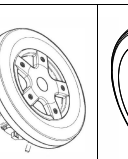
6.10.4 Specific Tightening Torques

	Drive Wheels								
	10" x 3"		12 1/2" x 2 1/4"			14"			
									
Wheel Fixation	70 Nm	70 Nm	33 Nm	35 Nm	70 Nm	33 Nm	60 Nm	25 Nm	18 Nm
Rim Halves	25 Nm	25 Nm	10 Nm	25 Nm	25 Nm	10 Nm	25 Nm	25 Nm	18 Nm

	Castor Wheels									
	6"		8"				9"		10"	
Wheel Fixation	18 Nm	18 Nm	25 Nm	16 Nm	16 Nm	25 Nm	25 Nm	25 Nm	18 Nm	100 Nm
Rim Halves	10 Nm	25 Nm	5 Nm	—	—	—	25 Nm	5 Nm	25 Nm	25 Nm

6.10.5 Overview of Power Wheelchair Models and Wheel Types

- Not all wheel types are available for all power wheelchairs, see footnotes.
- The symbols indicate three tyre types:









pneumatic = black valve cap	puncture-protected = red valve cap	puncture-proof = no valve

Models	Drive wheels								
	10" x 3"	12 1/2" x 2 1/4"			14"				
	4-Spoke Rim (1-Bolt Installation)	3-Spoke Rim (1-Bolt Installation)	5-Spoke Rim (1-Bolt Installation)	5-Spoke Plastic Rim (1-Bolt Installation)	3-Spoke Rim (1-Bolt Installation)	5-Spoke Rim (1-Bolt Installation)*	5-Spoke Rim (5-Screw Installation)	5-Spoke Rim for True Track*	Solid Rim (5-screw installation)
TDX SP2									
Storm ⁴ Series									
Kite									
Bora									
Fox									
Stream									
Mirage									

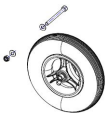
Models	Drive wheels								
	10" x 3"	12 1/2" x 2 1/4"			14"				
	4-Spoke Rim (1-Bolt Installation)	3-Spoke Rim (1-Bolt Installation)	5-Spoke Rim (1-Bolt Installation)	5-Spoke Plastic Rim (1-Bolt Installation)	3-Spoke Rim (1-Bolt Installation)	5-Spoke Rim (1-Bolt Installation)*	5-Spoke Rim (5-Screw Installation)	5-Spoke Rim for True Track*	Solid Rim (5-screw installation)
Dragon			<input type="checkbox"/> <input checked="" type="checkbox"/>	<input type="checkbox"/>					
Pronto M41	<input checked="" type="checkbox"/>								
AVIVA RX									<input type="checkbox"/> <input checked="" type="checkbox"/> <input checked="" type="checkbox"/>

* For wheelchair-specific mounting instruction, see respective manual.

Models	Castor Wheels									
	6"	8"				9"		10"		
	Single-Sided/Double-Sided Fork	Double-Sided Fork				Single-Sided/Double-Sided Fork	Double-Sided Fork	Single-Sided/Double-Sided Fork	Double-Sided Fork	Single-Sided Fork
TDX SP2	<input checked="" type="checkbox"/>									
Storm ⁴ Series								<input type="checkbox"/> <input checked="" type="checkbox"/> <input checked="" type="checkbox"/>	<input type="checkbox"/> <input checked="" type="checkbox"/> <input checked="" type="checkbox"/>	
Kite						<input checked="" type="checkbox"/> <input checked="" type="checkbox"/>		<input type="checkbox"/> <input checked="" type="checkbox"/> <input checked="" type="checkbox"/>	<input type="checkbox"/> <input checked="" type="checkbox"/> <input checked="" type="checkbox"/>	
Bora		<input checked="" type="checkbox"/>		<input type="checkbox"/> <input checked="" type="checkbox"/>	<input checked="" type="checkbox"/>	<input type="checkbox"/> <input checked="" type="checkbox"/>				
Fox		<input checked="" type="checkbox"/>	<input checked="" type="checkbox"/>							
Stream						<input checked="" type="checkbox"/>				
Mirage		<input checked="" type="checkbox"/>	<input type="checkbox"/> <input checked="" type="checkbox"/>		<input checked="" type="checkbox"/>					
Dragon						<input checked="" type="checkbox"/>				

Models	Castor Wheels									
	6"		8"				9"		10"	
										
	Single-Sided/ Double-Sided Fork	Double-Sided Fork				Single-Sided/ Double-Sided Fork	Double-Sided Fork	Single-Sided/ Double-Sided Fork	Double-Sided Fork	Single-Sided Fork
Pronto M41	■									
AVIV-A RX					■		□ ■ ■			

* For wheelchair-specific mounting instruction, see respective manual.

6.10.6 Replacing Drive Wheel (5–Screw Installation)

This chapter deals with drive wheels that are installed with four or five screws.



CAUTION!

Risk of Crushing to Hands and Feet by Weight of Mobility Device

- Pay attention to hand and feet.
- Use proper lifting techniques.



CAUTION!

Risk of Uncontrolled Movement of Mobility Device

- Turn off power supply (ON/OFF key).
- Engage drive.
- Before raising mobility device, secure wheels by blocking them with wedges.
- Prevent the mobility device tipping by propping it up on a wooden block which is long and wide enough under the battery case. If the wooden block is too short or too high, the mobility device can still tip.



- 6 mm Allen key
- 13 mm wrench
- Torque wrench
- Oblong wooden block (at least 12 x 12 x 30 cm) for propping up mobility device

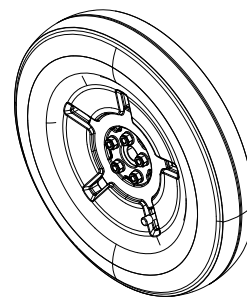

- Torx wrench with TX 40 bit
- Torque wrench
- Mounting kit
- Oblong wooden block (at least 12 x 12 x 30 cm) for propping up mobility device

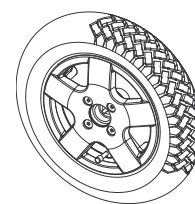



- 6 mm Allen key
- Torque wrench
- Oblong wooden block (at least 12 x 12 x 30 cm) for propping up mobility device
- Medium-strength thread locking adhesive (Loctite 243 or similar)

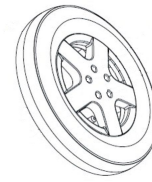

When removing, take care of small parts such as screws and washers. Put all small parts down so that they can be installed in correct sequence.

1. Remove legrests.
2. Place wooden block under frame to prevent mobility device from rolling away.
3. Loosen and remove screws which secure wheel.
4. Remove wheel from hub.
- 5.



CAUTION!

Risk of Injury if Wheels Come Off

- If drive wheels are insufficiently tightened during assembly, they can come off during driving.
- Always use new screws with undamaged coating.
 - Tighten screws to prescribed torque when mounting drive wheels.

Install parts in reverse order.

6. When installing wheel, pay attention to correct direction of rotation.

6.10.7 Replacing Castor Wheel on Double-Sided Fork



- 5 mm Allen key
- 13 mm wrench
- Oblong wooden block (at least 14 x 14 x 30 cm)



- 13 mm wrench (2x)
- Oblong wooden block (at least 14 x 14 x 30 cm)



- 6 mm Allen key
- 13 mm wrench
- Oblong wooden block (at least 14 x 14 x 30 cm)

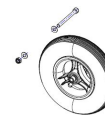

- 6 mm Allen key
- 13 mm wrench
- Oblong wooden block (at least 14 x 14 x 30 cm)

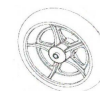

- 5 mm Allen key
- Oblong wooden block (at least 14 x 14 x 30 cm)



- 5 mm Allen key
- 13 mm wrench
- Oblong wooden block (at least 14 x 14 x 30 cm)



Removing Wheel

1. Place wooden block underneath mobility device and prop up mobility device.
2. Remove end-caps from bolt and nut (if applicable).

3.

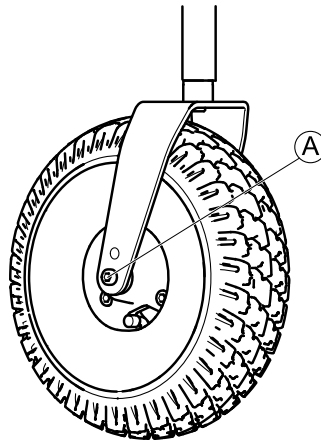

Fig. 6-38

Remove nut from bolt (A).

4. Remove bolt and wheel from fork.

Installing Wheel

1. Install parts in reverse order.
2. When installing wheel, pay attention to correct direction of rotation.
3. Tighten nut to prescribed torque. See 6.10.4 *Specific Tightening Torques*, page 45.

Replacing Castor Wheel (Aviva RX and Storm⁴ Max)



- 5 mm Allen key (up to August 2016)
- TX40 Torx key (starting August 2016)
- Oblong wooden block (at least 14 x 14 x 30 cm)

Removing Wheel

1. Loosen and remove bolts (A).
- 2.

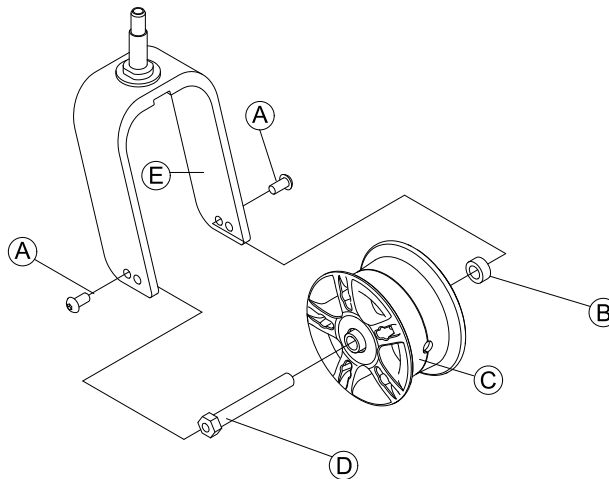

Fig. 6-39

Pull wheel (C) including axle (D) and bushing (B) out of fork (E).

Installing Wheel



CAUTION!

Risk of injury from wheels coming loose

If wheels are insufficiently secured during mounting, it can come loose when driving.

- When mounting wheels tighten bolts with prescribed torque.
- Secure all bolts using a suitable blocker.
- Never use normal nuts instead of self-locking nuts.
- Always use new nuts and bolts with an undamaged coating.

1. Install parts in reverse order. Pay attention to correct direction of rotation when installing wheels.
2. Test all functions.

Replacing Castor Wheel (6 inch wheel)



- 2 x 7/16 inch wrench
- Oblong wooden block (at least 14 x 14 x 30 cm)



Removing Wheel

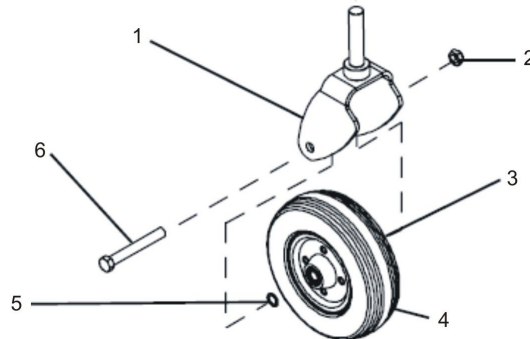

Fig. 6-40

1. Loosen nut (2).
2. Remove screw (6).
3. Remove two washers (3) and (5).
4. Remove wheel (4).
5. Replace any defective parts.

Installing Wheel

1. Install parts in reverse order.
2. When installing wheel, pay attention to correct direction of rotation.
3. Tighten nut to prescribed torque. See 6.10.4 *Specific Tightening Torques*, page 45.

6.10.8 Replacing Castor Wheels on Single-Sided Fork



- 24 mm wrench
- Oblong wooden block (at least 14 x 14 x 30 cm)



Removing Wheel

1. Place wooden block underneath mobility device and prop up mobility device.
2. Remove end-caps from bolt and nut (if applicable).
3. Remove nut and washer from bolt.
4. Remove bolt and wheel from fork.

Installing Wheel

1. Install parts in reverse order.
2. When installing wheel, pay attention to correct direction of rotation.
3. Tighten nut to prescribed torque. See 6.10.4 *Specific Tightening Torques*, page 45.

Replacing Castor Wheel (AVIVA RX, TDX SP2)



- TX30 Torx key (TDX SP2)
- TX40 Torx key (AVIVA RX)
- Oblong wooden block (at least 14 x 14 x 30 cm)



Removing Wheel

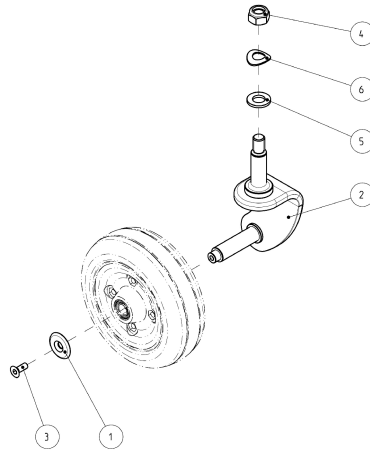

Fig. 6-41

1. Loosen and remove screw (3) including washer (1).
2. Remove castor.
3. Replace castor.

Installing Wheel

1. Install parts in reverse order.
2. When installing wheel, pay attention to correct direction of rotation.
3. Tighten screw (3).

6.10.9 Replacing Tyres

Repairing Pneumatic and Puncture-Protected Tyres



- 6 mm Allen key
- Tightening kit
- Oblong wooden block (at least 12 x 12 x 30 cm) for propping up mobility device
- Repair kit for tyre repair or a new inner tube
- Talcum powder
- Tyre pump or compressor



WARNING!

Risk of Injury

If tyre with one or more damaged rim threads is inflated, rim could burst and cause serious injury.

- Do not inflate tyre if one or more rim threads are damaged.
- Immediately replace rim with damaged threads.



WARNING!

Risk of Explosion

There is considerable pressure in the tyre. Risk of injury. Parts can be thrown out and injure you if you do not secure rim halves.

- Secure rim halves with joiner's clamps.



Risk of Damage to Rim Threads

Incorrectly tightened screws can cause damage to rim threads.

- Tighten rim screws with prescribed tightening torque.

1. Remove wheel as described in respective chapter in this manual.



CAUTION!

Risk of Damage by Gel When Repairing Puncture-Protected Tyres With Red Valve Caps

Valve can become blocked by the puncture protection gel and get unusable.

- During following work you should always hold up valve so that puncture protection gel cannot enter valve.

2. Remove valve cap.

- Let air escape completely out of tyre by firmly pressing in pin in the centre of valve.

**CAUTION!****Risk of Explosion**

The wheel explodes if air pressure has not been released from wheel before wheel rim is removed.
– Always let all air out of tyre before removing rim.

-

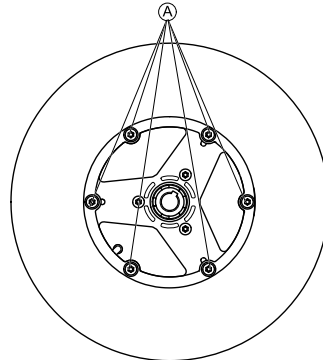

Fig. 6-42 This picture is an example.

Remove screws (A) on inside of wheel.

- Remove rim halves from wheel.
- Remove inner tube from tyre.
- Repair inner tube and re-fit it, or replace it with a new one.



If old inner tube has been repaired and is to be used again, and became wet during repair, it is easier to replace it if it is lightly dusted with talcum powder beforehand.

- Install tyre in reverse order.
- Apply rim halves to wheel.
- Inflate tyre a little.
- Place screws in wheel rim and tighten screws with prescribed torque. Make sure that inner tube is not clamped between wheel rim halves.
- Make sure that tyre is contacting wheel rim directly.
- Inflate tyre to prescribed pressure.
- Make sure that tyre is still closely contacting wheel rim.
- Screw valve cap on.
- Install wheels according to instruction. See respective chapter.

Repairing Solid Tyre



- 6 mm Allen key
- 3 joiner's clamps with plastic caps

**Risk of Damage to Rim Threads**

Incorrectly tightened screws can cause damage to rim threads.
– Tighten rim screws with prescribed tightening torque.

- Remove wheel as described in respective chapter in this manual.
- Secure rim halves against unexpected discharge with three joiner's clamps. When doing so, make sure that you do not scratch rims.
-

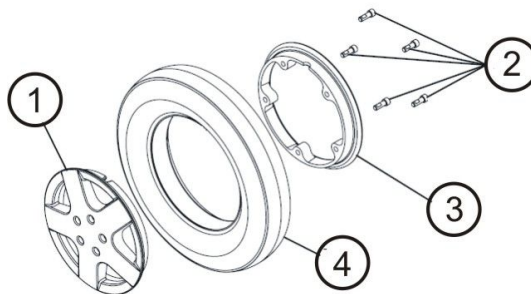



Fig. 6-43

Loosen and remove screws (2) on inside of wheel.

- Loosen joiner's clamps carefully and alternately until you can remove rim halves without risk.
- Remove inner (3) and outer (1) half of rim from tyre (4).
- Replace any defective or worn parts.
- Install tyre in reverse order.

8. When fitting rim halves together, make sure that drill holes and threads for screws are placed exactly on top of each other.
9. Place joiner's clamps in position.
10. Tighten joiner's clamps alternately in small stages until rim halves are precisely aligned.
11. Install and tighten screws.
12. Remove joiner's clamps.
13. Install wheel as described in respective chapter in this manual.

6.10.10 Replacing drive wheel hub

-
-  • 19 mm wrench
-

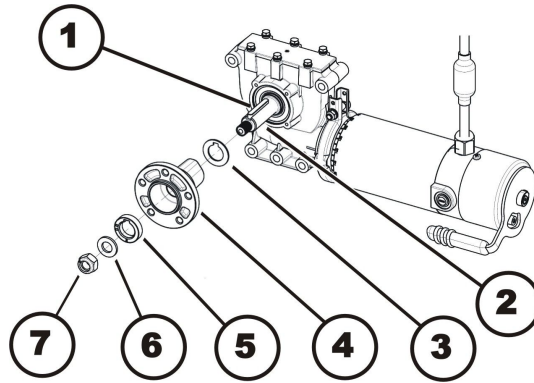

Removing drive wheel hub

1. Loosen and remove nut (7).
2. Remove washer (6).
3. Remove distance ring (5).
4. Remove wheel hub (4) from axle (2).
5. Remove shim rings (3).
6. Remove feather key (1) from axle.

Installing drive wheel hub

1. Install drive wheel hub parts in reverse order.
2. Use thin film of lubricant to easier install wheel hub on axle.
3. Tighten nuts (4) to 60 Nm.

6.10.11 Replacing Manual Wheel Lock

-
-  • 13 mm open-ended wrench
• 13 mm wrench
-

1. Hold nuts (F) and washers (E) in place. Loosen and bolts (A) and (B) including wheel lock (C).
2. Remove nuts and washers.
3. If necessary, replace wheel lock mount (D). See 6.9.1 *Replacing Motor-Gearbox Unit, page 38.*

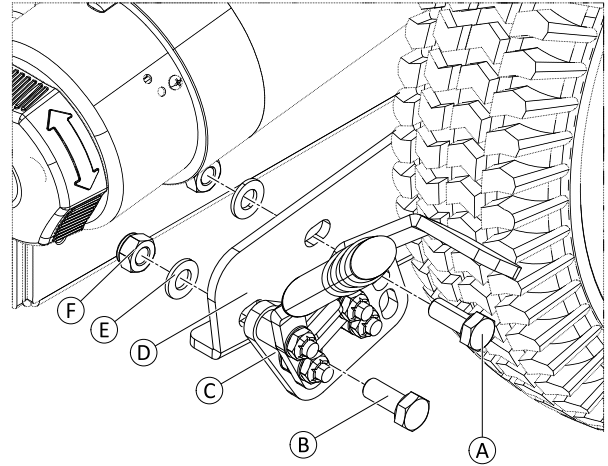

Fig. 6-44

4. Install bolts to corresponding holes (G) and (H) on wheel lock.
5. Install assembly to wheel lock mount.
6. Install washers and nuts.
7. Tighten bolt (B).
8. Rotate wheel lock clockwise. Tighten bolt (A).
9. Test all functions.

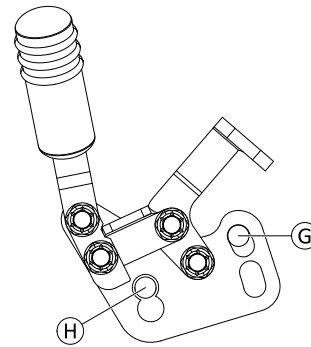



Fig. 6-45

6.10.12 Replacing Anti-Tipper Unit

-  • 6 mm Allen key
-  • 8 mm Allen key

1. Loosen and remove screw (A) and wedge lock washer (B).
2. Loosen and remove screw (C).
3. Remove folded sheet (D).
4. Pull off anti-tipper unit (E) from stay bolts (not shown).
5. Install parts in reverse order.
6. Test all functions.

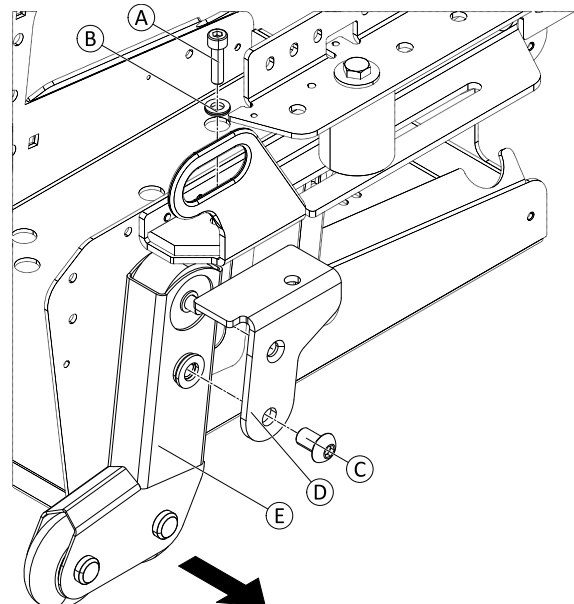



Fig. 6-46

6.10.13 Replacing Anti-Tipper Wheel

-  Versions of this component up to October 2020 are equipped with Starlock washers instead of screws. These versions are not serviceable, but can be converted to the version with screws.



- 3 mm Allen key (2x)
 - Flat screwdriver (versions with Starlock washer only)
-

1. Loosen and remove bolt / starlock washer (A).
2. Remove (sleeve) bolt (B). Pay attention to wheel (C).
3. Replace wheel, sleeve bolt and bolt.
4. Install parts in reverse order. Tighten bolt (A) to 3 Nm.
5. Test all functions.

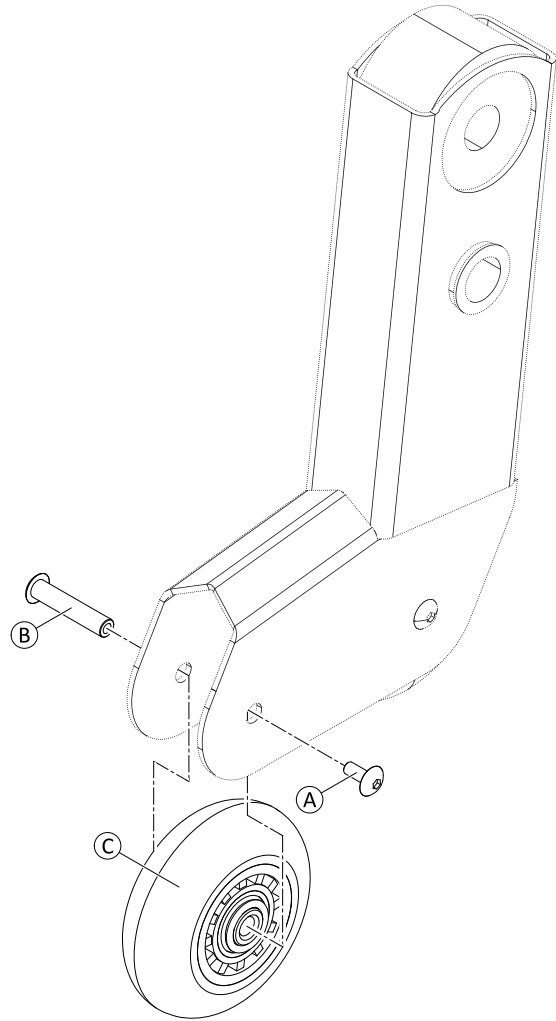

Fig. 6-47

6.11 Electronics

6.11.1 Replacing Power Module



- 4 mm Allen key
-

Removing Module

1. Remove power module shrouds. See 6.7.1 *Power Module Shrouds*, page 24.
2. Unplug all cables from module.
3. Loosen and remove screw (F), washer (E) and lock washer (D)
4. Remove module (B).

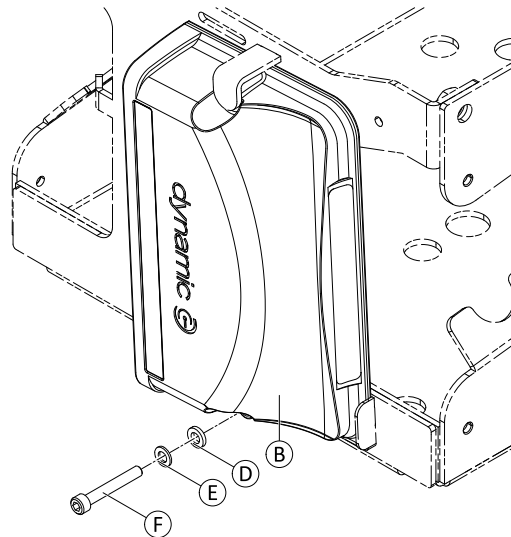

Fig. 6-48

Installing Module

1. Install module (B) to top latch (A) from downwards direction.
2. Swivel module to bottom latch (C). Make sure that module is correctly installed on inner sides of latches (see figure on right side).

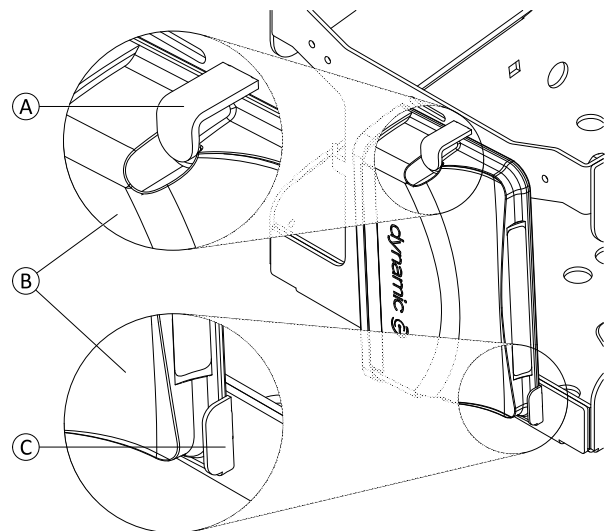



Fig. 6-49

3.  Ensure to install lock washer (D) alongside to module. Lock washer must have contact to module for proper working.
Re-install screw, washer and lock washer. Tighten screw.
4. Re-install shrouds.
5. Plug in cables.
6. Perform calibration process. See in LiNX service manual.
7. Test all functions.

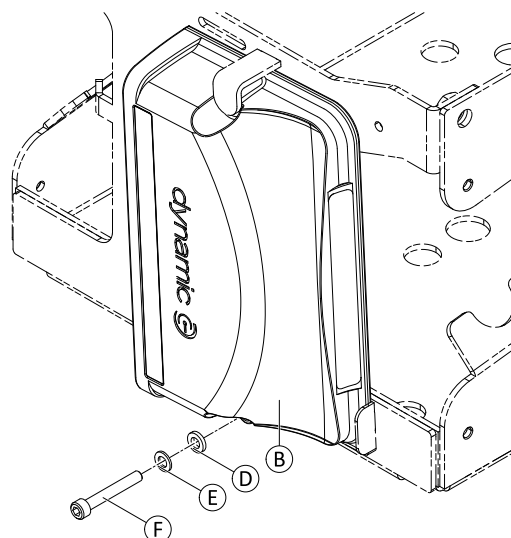

Fig. 6-50

6.11.2 Replacing Bus Expansion Block (GLM-CONX4)

The bus expansion block allows you to increase the amount of available bus sockets.



- Phillips screwdriver, size 2

1. Unplug all bus cables.
2. Loosen and remove screws (B).
3. Replace block (A).
4. Install parts in reverse order. Tighten screws to 4 Nm.
5. Plug in all bus cables.
6. Test all functions.

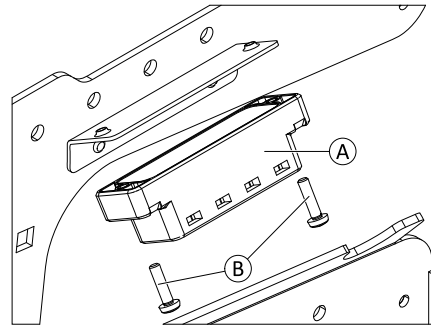

Fig. 6-51

6.11.3 Replacing G-Trac Sensor



- 4 mm Allen key
- 10 mm wrench

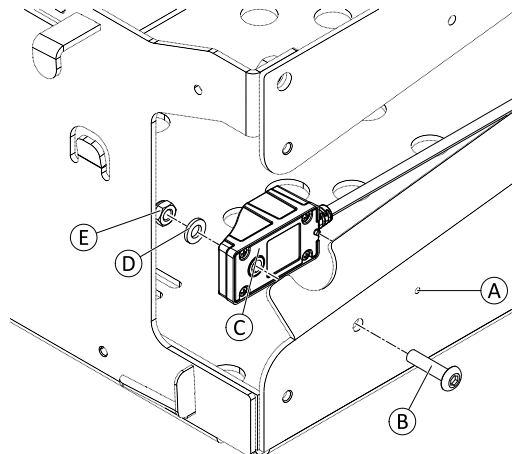

Fig. 6-52

Removing sensor

1. Remove batteries. See 6.12 *Batteries*, page 60.
2. Unplug sensor cable from power module.
3. Loosen and remove nut (E) and washer (D).
4. Remove bolt (B) and sensor (C).

Installing sensor



CAUTION!

Risk of injury and damage due to uncontrolled movement of mobility device

An incorrect installed sensor sends wrong data to the power module.

- Ensure that sensor is installed with cable pointing sideways.
- Ensure that nib on backside of sensor is engaged in its installation hole.

1. Install parts in reverse order.
2. Check that sensor is installed with cable pointing sideways and correctly engaged nib in its installation hole (A).
3. Plug in sensor cable to power module.
4. Test all functions.

6.11.4 Replacing Operating Hour Counter/ Connecting Cable

The counter is located on rear shroud.

Removing Counter

1. Switch controls system of wheelchair off.
2. Remove rear shroud. See 6.7 *Shrouds*, page 24.
3. Loosen and remove nut ④ including locking washer ⑤.
4. Pull mounting bracket ③ off of threaded rod ⑥.
5. Remove retaining frame ②.
6. Pull counter ① forwards out of rear shroud.
7. Unplug cable wires (not shown in the illustration) from pins.
8. Replace counter and cable respectively.

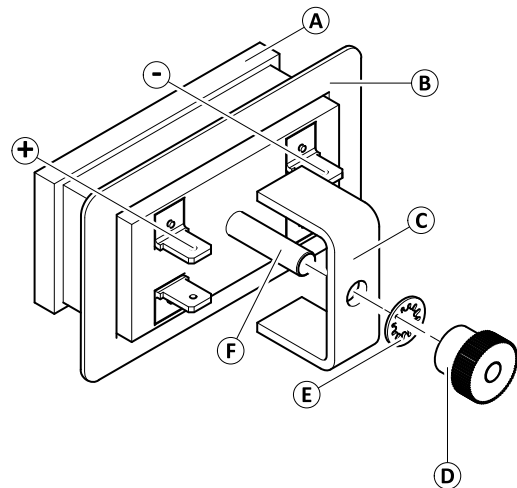

Fig. 6-53

Installing Counter



Risk of damage

If counter is wrongly connected. If plus and minus wires are connected wrong way, it will damage electronic components of operating hour counter.
– Make sure cable is connected correctly.

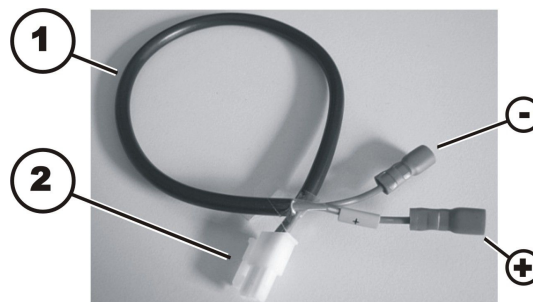

1. Plug in blue wire (-) to pin 2 and brown wire to pin 1 on counter, which is marked with a "minus" symbol. The brown wire is additionally marked with yellow sleeve with "plus" symbol on it.
2. Insert cable from outside through cut-out for counter located in rear.
3. Position counter ① in cut-out.
4. Reposition retaining frame ②.
5. Place mounting bracket ③ on threaded rod ⑥ so that mounting bracket presses retaining frame on shroud.
6. Place locking washer ⑤ and nut ④ on threaded rod.
7. Tighten nut hand-tight.
8. Install shroud.

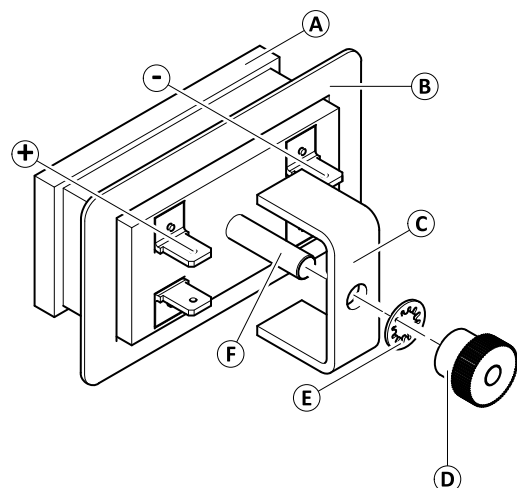



Fig. 6-54

6.11.5 Replacing Cable Harness

According to the configuration of the mobility device different variants of the cable harness are used. The course of action is the same for all variants.

 If you want to retrofit an option, such as light, it may require a new cable harness.

1. Remove right power module shroud.
2. Unplug all cables on power module.
3. Remove rear shroud. If fitted, unplug cables of rear lights.
4. Unplug all cables between chassis and seating system.
5. Remove battery shroud.
6. Remove batteries.
7. Remove main frame shrouds.
8. If fitted, unplug cables of headlight.
9. Replace cable harness.
10. Install parts in reverse order.
11. Test all functions.

6.11.6 Updating Software

See LiNX service manual.

6.12 Batteries



CAUTION!

Injury hazard and possible material damages if batteries are handled improperly

The installation of new batteries may only be carried out by authorised specialists.

- Observe the warning information on the batteries.
- Only use battery versions stated in the specifications.



CAUTION!

Fire and burns hazard if battery terminal is bypassed

– Take great care to ensure that the battery terminals are never short-circuited with tools or mechanical mobility device parts.

- Ensure that the battery terminal caps have been replaced if you are not working on the battery terminals.



CAUTION!

Risk of crushing

Batteries can be extremely heavy. This results in injury hazards to your hands.

- Handle the batteries with care.
- Ensure that batteries do not fall to the ground when removed from chassis.
- Pay attention to hands.
- Use proper lifting techniques.



WARNING!

Burn hazard

Injury hazard due to discharged acid.

- Always wear acid-proof protective gloves when handling batteries.
- Always wear protective goggles when handling batteries.

What to do if acid is discharged

- Always take clothing which has been soiled by or dipped in acid off immediately!
- Rinse any areas of your skin which has come into contact with battery acid off immediately with plenty of water!

If contact with eyes is made

- You should also consult an eye specialist immediately afterwards!



When removing, take care of small parts such as screws and washers. Put all small parts down so that they can be installed in correct sequence.

6.12.1 General Instructions on Handling Batteries

- Never mix and match different battery manufactures or technologies, or use batteries that do not have similar date codes.
- Never mix gel with AGM batteries.
- The batteries reach their end of life when the drive range is significantly smaller than usual. Contact your provider or service technician for details.
- Always have your batteries installed by a properly trained mobility device technician or a person with adequate knowledge. They have the necessary training and tools to do the job safely and correctly.

6.12.2 Handling Damaged Batteries Correctly



CAUTION!

Corrosion and burns from acid leakage if batteries are damaged

– Remove clothes that have been soiled by acid immediately.

After contact with skin:

– Immediately wash affected area with lots of water.

After contact with eyes:

– Immediately rinse eyes under running water for several minutes; consult a physician.

- Always wear safety goggles and appropriate safety clothing when handling damaged batteries.
- Place damaged batteries in an acid-resistant receptacle immediately after removing them.
- Only ever transport damaged batteries in an appropriate acid-resistant receptacle.
- Wash all objects that have come into contact with acid with lots of water.

Disposing of Dead or Damaged Batteries Correctly

Dead or damaged batteries can be given back to your provider or directly to Invacare.

6.12.3 Making Batteries Accessible



- 4 mm Allen key
- 11 mm wrench (60 Ah/73.5 Ah battery)
- Phillips screwdriver, size 2 (52 Ah battery)
- Flat screwdriver

1. Remove right power module shroud and rear shroud. See 6.7 Shrouds, page 24.
2. Unplug battery cable on power module.
3. Remove circuit breaker. See 6.12.5 Replacing Circuit Breaker, page 62.
4. Open battery strap (B).
5. Loosen and remove hand screw (A).
6. Swivel fixation plate (C) sideways and remove.

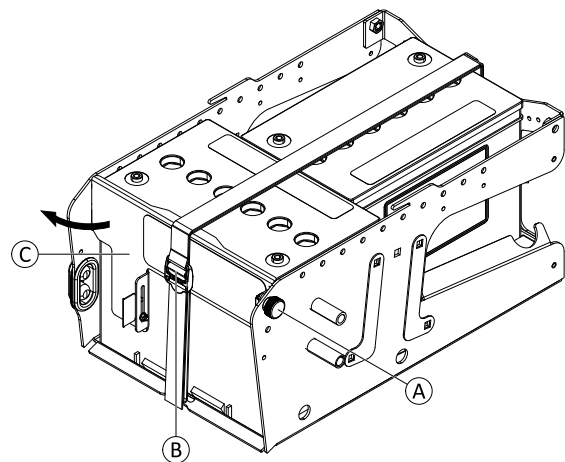

Fig. 6-55

6.12.4 Replacing Batteries



- 4 mm Allen key
- 11 mm wrench (60 Ah/73.5 Ah battery)
- Phillips screwdriver, size 2 (52 Ah battery)
- Flat screwdriver
- Wooden block (at least 7.5 cm x 7.5 cm x 30 cm)

Removing Batteries

1. Make batteries accessible. See 6.12.3 *Making Batteries Accessible*, page 61.
2. Remove remaining terminal cap ① and terminal screw ② together with washer ③ and cable lug of cable harness from terminal of rear battery.
3. Remove rear battery using battery strap.
4. Pull out front battery carefully using battery strap.
5. Remove remaining terminal cap and terminal screw together with washer and cable lug of cable harness from terminal of front battery.
6. Remove front battery.
7. If necessary, replace inlays.

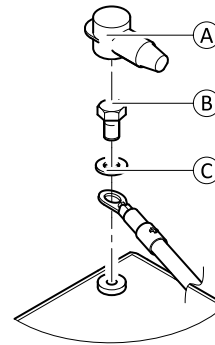

Fig. 6-56 Positive terminal serves as an example.

Installing Batteries

①	52 Ah/60 Ah battery
②	73.5 Ah battery

1. Install batteries in reverse order.
2. Make sure that battery box sockets/plugs have been correctly refitted. Polarity diagram is located on fixation plate.
3. Install fixation plate to corresponding mounting holes ① or ②.
4. Install remaining parts in reverse order.
5. Test all functions.

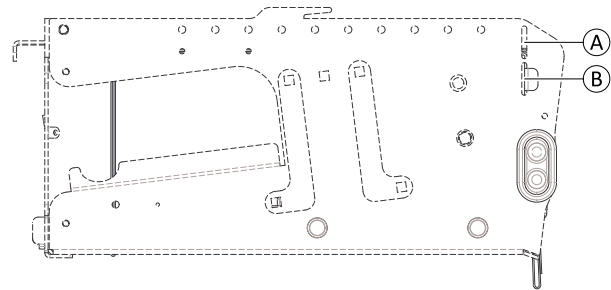





Fig. 6-57

6.12.5 Replacing Circuit Breaker

i If the circuit breaker is damaged, you must replace it together with the battery cables.

Removing Circuit Breaker

-  • 4 mm Allen key
-  • 11 mm wrench (60 Ah/73.5 Ah battery)
-  • Phillips screwdriver, size 2 (52 Ah battery)
-  • Flat screwdriver

1. Remove right power module shroud and rear shroud.
2. Unplug battery cable on power module.
3. Disconnect circuit breaker cables from batteries. Disconnect negative terminal first, then positive terminal.
 - a. Remove tie wraps (not shown).
 - b. Remove terminal caps (A).
 - c. Loosen and remove terminal screws (B) together with washers (C) and cable lug from terminal.

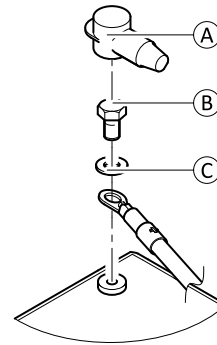

Fig. 6-58 Positive terminal serves as an example.

4. Loosen clip (D).
5. Remove circuit breaker together with cables.

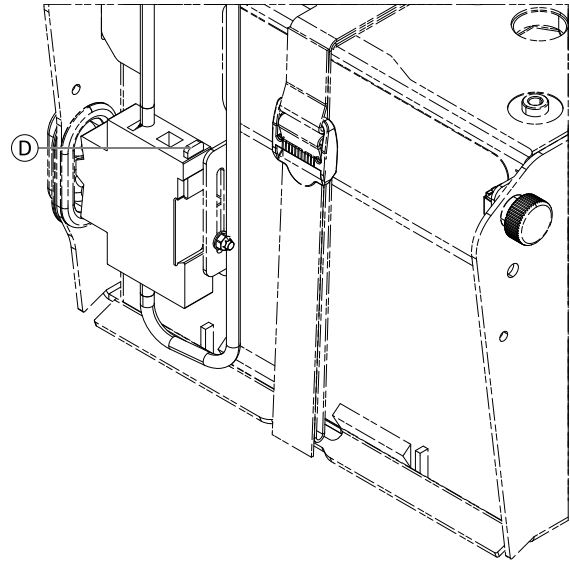

Fig. 6-59

Replacing Holder



- 7 mm wrench

1. Remove circuit breaker.
2. Loosen and remove nut ⑤, washer ⑥ and holder ③.
3. Install parts in reverse order.

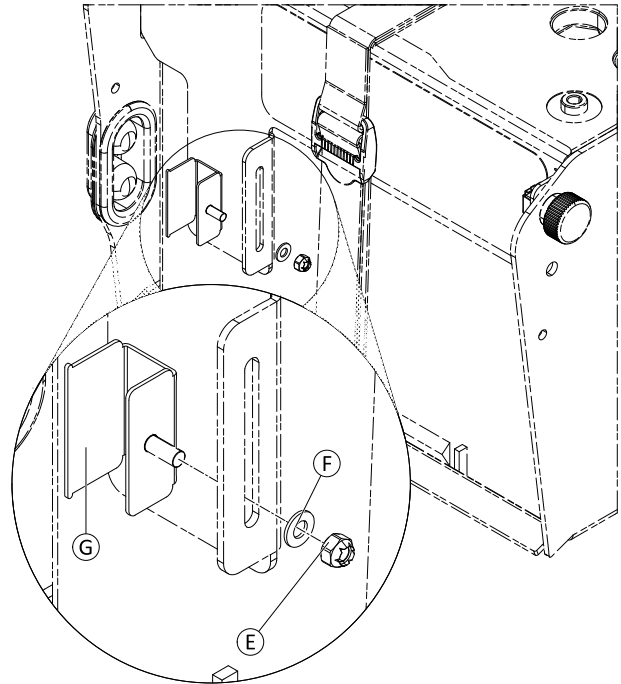



Fig. 6-60

Installing Circuit Breaker

 Connect negative terminal first, then positive terminal.

1. Install holder and circuit breaker in reverse order. Ensure that clip ④ faces upwards. Reposition terminal caps and secure them with UL94V0 tie wraps.
2. Adjust circuit breaker and holder to correct position. See below.
3. Plug in battery cable on power module.
4. Install shrouds.
5. Test all functions.

Adjusting Mounting Position of Holder

 • 7 mm wrench

1. Loosen nut ⑤.
2. Move holder and circuit breaker to correct mounting position (see figure).
3. Re-tighten nut.

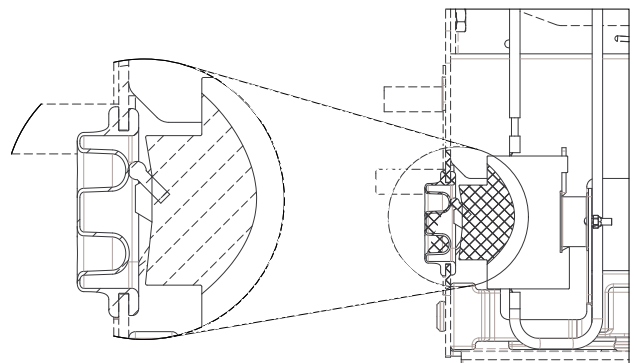

Fig. 6-61

6.12.6 Checking Cables

1. Turn off electronics on remote.
2. Remove rear shroud. See 6.7 Shrouds, page 24.
3. Remove batteries. See 6.12 Batteries, page 60.
4. Check all cables for visible damage, crushing points or abrasion points.
5. Replace damaged cables.
6. Pull on each plug carefully. The plug must not come out of its socket when pulled on lightly.

7. If a plug is loose, apply slight pressure to push plug into socket. The plug must snap in place securely.
8. Check that plug is firmly attached to its socket.
9. Install parts in reverse order.
10. Test all functions.

6.13 Lighting unit

6.13.1 Replacing Headlight



- 3 mm Allen key
- 8 mm wrench
- Oblique pliers
- Tie wraps

1. Remove front part of main frame shrouds. See 6.7.3 *Main Frame Shrouds, page 25*
2. Unplug cable and cut tie wraps from headlight affected.
3. Pull cable out of guidance.
4. Loosen and remove nut (A) and washer (B).
5. Remove bolt (D), washer (B) and headlight (C).
6. Replace headlight.

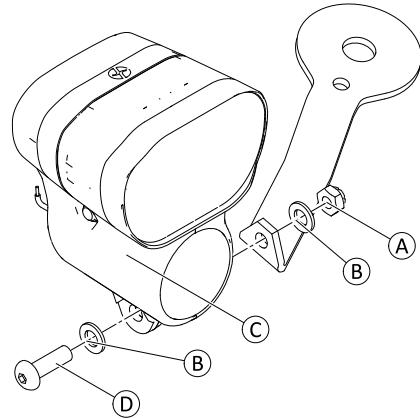

Fig. 6-62

7. Install parts in reverse order.
8. Route cables carefully and fix them with cable ties.
9. Tighten nut finger-tight.
10. Test all functions.
11. Adjust headlight roughly using grid. User can carry out final adjustment according to user manual.

6.13.2 Replacing Headlight Holder



- 3 mm Allen key
- 6 mm Allen key
- 8 mm wrench
- 13 mm wrench
- Oblique pliers
- Tie wraps

Removing Holder

1. Remove complete headlight. See 6.13.1 *Replacing Headlight, page 65*.
2. Loosen and remove nut ⑤.
3. Remove holder ④ including bushing ③. Do not remove bolt ① and washer ② for correct re-installing of holder.

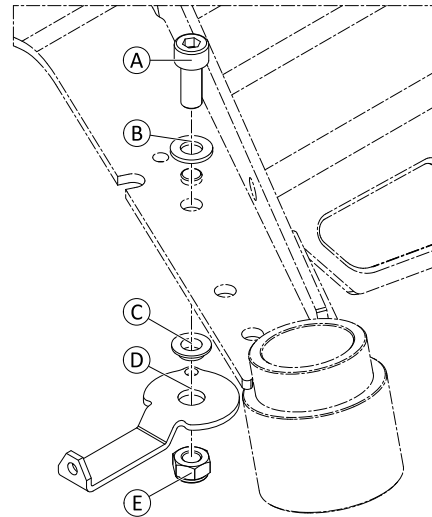

Fig. 6-63

Installing Holder

1. Install parts in reverse order. Tighten nut ⑤ to 6 Nm.
2. Test all functions.

6.13.3 Replacing Rear Light



This component is not serviceable. Replace the bottom part of the rear shroud instead.

6.14 Seating

This chapter deals with the replacement of interface components between the base of the mobility device and the corresponding seating system.

For detailed instructions on the seating system, see the service manual of the corresponding seating system.

6.14.1 Replacing Actuator/Spindle — Tilt with Fixed Pivot Point

-
-  Flat screwdriver
 -  Oblong wooden block (at least 7.5 cm x 7.5 cm x 35 cm)
-

Removing Actuator

-  When removing, take care of small parts such as spacers. Put all small parts down so that they can be installed in the correct sequence.



CAUTION! **Risk of crushing**

Seat comes down when actuator is removed.

- Hold the seat in position while removing the actuator.
- Move the seat into service position and place a wooden block under the backrest, or lower it carefully to the chassis.

1. Unplug actuator cable directly on actuator.
2. Remove SL retainer clips (A) and spacers (F) on actuator at top and bottom.
3. Remove upper pin (B). Hold seat in position.
4. Move seat into service position. Alternatively, lower it carefully to chassis.
5. Remove lower pin (D) and actuator (C) with mounting hardware (E).

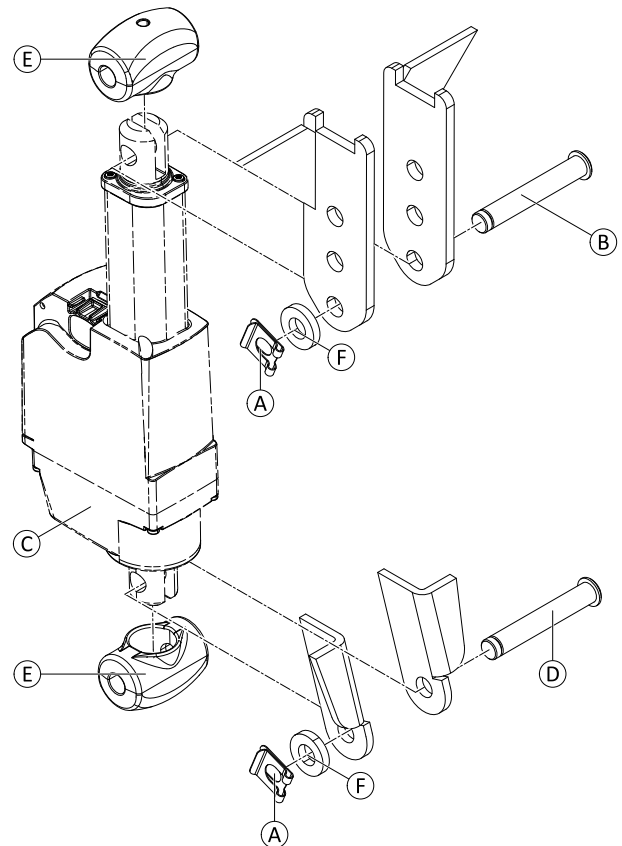

Fig. 6-64 For better view only the actuator, pins, spacers and SL retainer clips are shown.

Installing Actuator

1. Install parts in reverse order.
2. Test all functions.

6.14.2 Replacing Height Adjustment Bracket — Tilt and Lifter-Tilt Modules

This chapter deals with replacing the height adjustment brackets for a seat with tilt or lifter-tilt module. Replacing the brackets by other variants (see spare parts catalogue) allows to retrofit another seat height to the mobility device.



CAUTION!
Risk of Crushing to Hands and Feet by Weight of Component

- Pay attention to hand and feet.
- Use proper lifting techniques.



CAUTION!
Risk of Uncontrolled Movement of Mobility Device

- Turn off power supply (ON/OFF key).
- Engage drive.
- Before raising mobility device, secure wheels by blocking them with wedges.
- Prevent the mobility device tipping by propping it up on a wooden block which is long and wide enough under the battery case. If the wooden block is too short or too high, the mobility device can still tip.



- 4 mm Allen key
- Oblong wooden blocks (at least 6 cm x 6 cm x 30 cm)

1. Unplug all cables from the electronic modules which run from seat to chassis.
2. Loosen and remove screws **A** and washers **B** on both sides.
3. Remove seat including brackets **C** from chassis.
4. Place seat on wooden blocks.

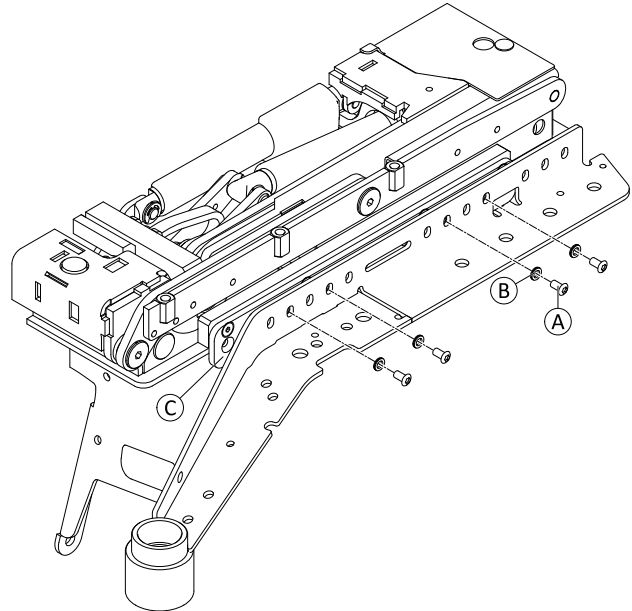

Fig. 6-65

5. Loosen and remove screws **D** on both sides.
6. Replace brackets **C** on both sides.
7. Re-install screws. Tighten screws.

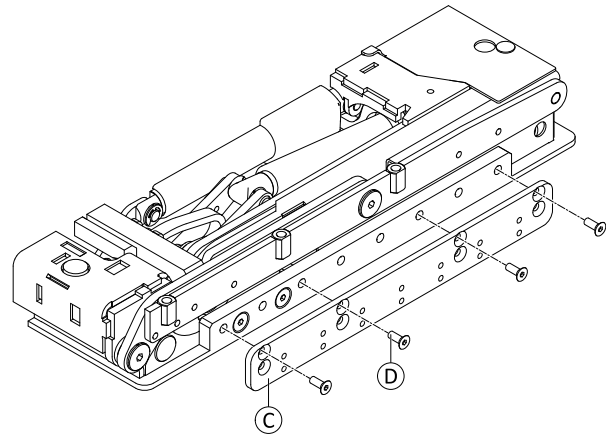

Fig. 6-66

8. Place seat including brackets on chassis.
9. Change position of seat according to required seat depth. See *4.3 Adjusting Centre of Gravity — Ultra Low Maxx Seat, page 9*.
10. Install screws **A** and washers **B**. Tighten screws.
11. Plug in all cables.
12. Test all functions.

6.15 Options

6.15.1 Replacing Luggage Carrier

-
- | | |
|--|--|
| | <ul style="list-style-type: none"> • 4 mm Allen key • 5 mm Allen key |
|--|--|
-

1. Loosen and remove screws (A) and wedge lock washers (B) on both sides.
2. Remove luggage carrier assembly (C, D, E) in backwards directions.

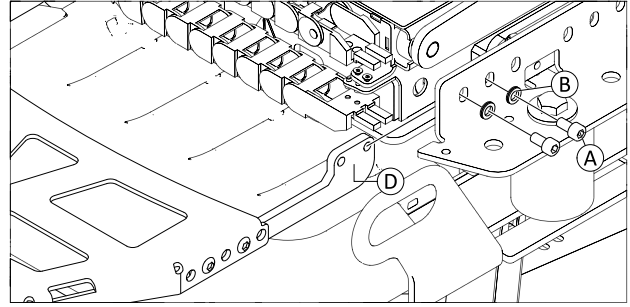

Fig. 6-67

3. Install fixture sheets (D) to mobility device using washers (B) and screws (A). Do not tighten screws.
- 4.

i When installing luggage carrier to mobility device you must ensure not to clamp or bend other components. Default mounting position (F) covers most uses cases. Depending on the installed configuration a change to position (G) or (H) may be necessary.

Install luggage carrier to fixture sheets using screws (E). Tighten screws (E).

5. Tighten screws (A).

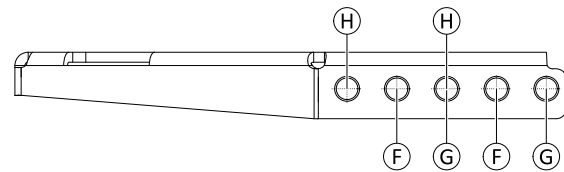
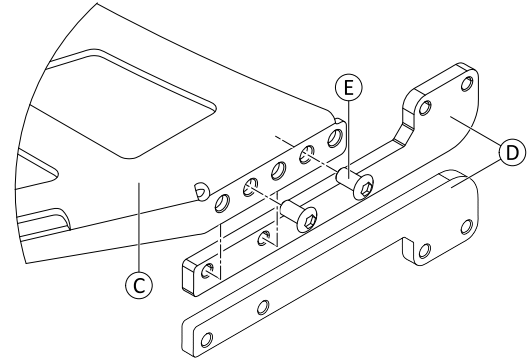





Fig. 6-68

7 Mounting Dahl Docking System

-  For more information about spare parts, accessory part installation in vehicles and maintenance of the Dahl Docking system, contact Dahl Engineering www.dahlengineering.dk.
-  To retrofit a mobility device with a Dahl Docking system, it is imperative, that the mobility device is equipped with the correct adapter plate. This adapter plate must be threaded to fix the lock plate of the Dahl Docking system underneath the mobility device. The maximum kerb weight of the mobility device must not exceed 200 kg.

- 
 - TX27 Torx key
 - Low-strength thread locking adhesive (Loctite 222 or similar)

1. Remove batteries. See *Removing Batteries*.
- 2.

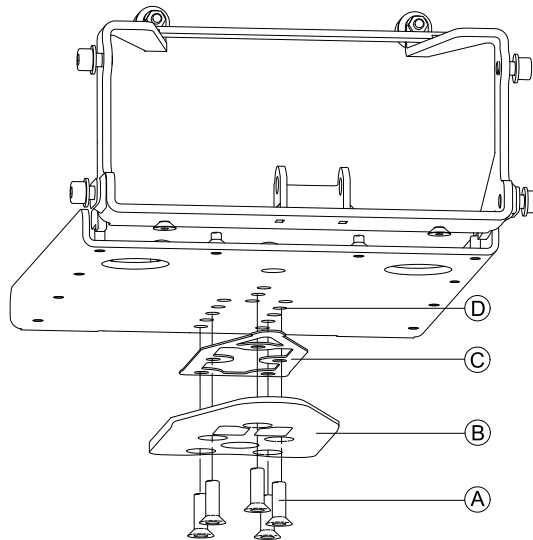



Fig. 7-1

Place screws (A), lock plate (B) and 8 mm spacer (C) on adapter plate (D).

-  8 mm spacer is mandatory. Additional spacers can be mounted to lock plate.

3.

-  **Do not use any other screws than those supplied from Dahl Engineering (Part No. 502800). Standard countersunk M8 screws are not strong enough in the event of a collision.**

Tighten screws (16 - 18 Nm).

4. Mark where to cut screws.
5. Remove screws, lock plate and spacer.
6. Cut screw.

-  It is very important to check correct length of screws. If screws are too short to reach through threads, screws do not have strength to carry required load. If screws are too long, batteries or other components can be damaged. If screws are cut too short, replace them with original Dahl screws only.

7. Apply thread locking adhesive on screws.
8. Tighten lock plate and spacer with screws (16 - 18 Nm).
9. Connect mobility device with Dahl Docking station. Make sure lock plate is securely locked and all release methods work as intended. For more information about using the Dahl Docking system, see user manual.

Installation of Dahl Docking System in Vehicles

Only professional companies in the business of converting or building mobility device accessible vehicles can order the Dahl Docking system from Dahl Engineering.

A qualified and experienced technician must carry out the installation. Dahl Engineering can provide vehicle specific installation instructions for a large range of vehicles.

Invacare Distributors

Australia:

Invacare Australia Pty. Ltd.
1 Lenton Place, North Rocks NSW
2151
Australia
Phone: 1800 460 460
Fax: 1800 814 367
orders@invacare.com.au
www.invacare.com.au

United Kingdom:

Invacare Limited
Pencoed Technology Park, Pencoed
Bridgend CF35 5AQ
Tel: (44) (0) 1656 776 222
Fax: (44) (0) 1656 776 220
uk@invacare.com
www.invacare.co.uk

Canada:

Invacare Canada L.P.
570 Matheson Blvd East, Unit 8
CDN Mississauga, On. L4Z 4G4
Phone: (905) 890 8300
Toll Free: 800.668.5324
www.invacare.ca

Eastern Europe, Middle East & CIS:

Invacare EU Export
Am Achener Hof 8
D-88316 Isny
Tel: (49) (0)7562 700 397
eu-export@invacare.com
www.invacare-eu-export.com

Ireland:

Invacare Ireland Ltd,
Unit 5 Seatown Business Campus
Seatown Road, Swords, County Dublin
Tel : (353) 1 810 7084
Fax: (353) 1 810 7085
ireland@invacare.com
www.invacare.ie

New Zealand:

Invacare New Zealand Ltd
4 Westfield Place, Mt Wellington 1060
New Zealand
Phone: 0800 468 222
Fax: 0800 807 788
sales@invacare.co.nz
www.invacare.co.nz

