

# SKEYE

*Mini Drone*

## USER GUIDE



 TRNDlabs

# Parts Identification

## SKEYE Mini Drone

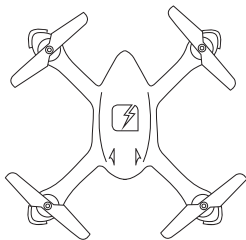

## USB Charging Cable

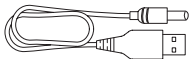

## MicroSD Card



## Rotor Protection Cage

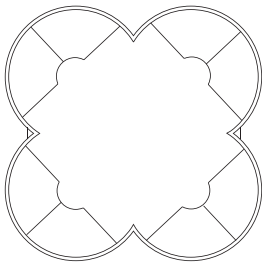

## Replacement Rotor Blades

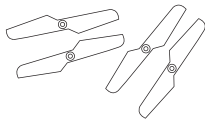

## MicroSD card reader

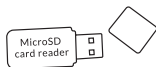

## Controller

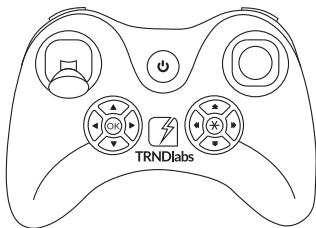

## Rechargeable Battery

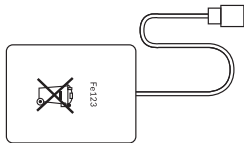

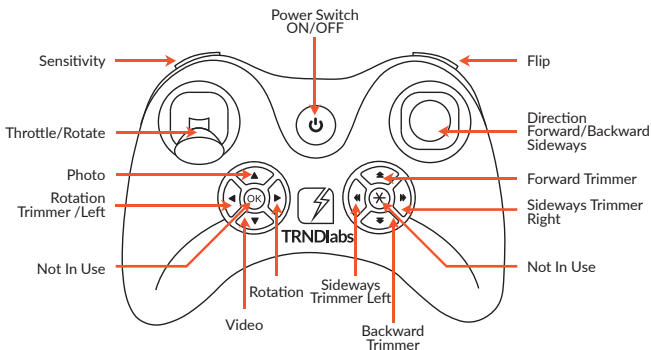

## Getting Started

### Battery Installation

1. Use a screwdriver to open the controller battery cover.
2. Install 4x 1.5V AA batteries into the controller.
3. Lock the battery cover.

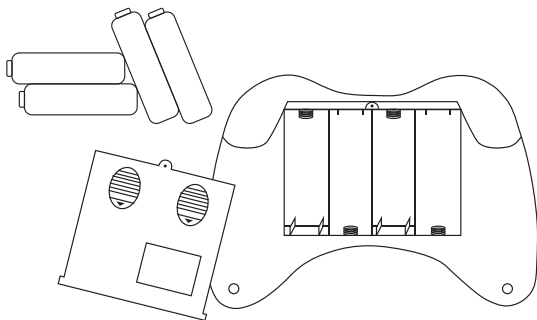

## Charging

1. Disconnect the power cable.



2. Connect the USB charging cable to a USB port. The LED on the USB charging cable lights red indicating that the battery is charging. When the battery is fully charged, the LED on the USB charging cable turns off. It takes about 60 minutes to recharge a discharged battery.



**WARNING**

Make sure you only charge the rechargeable battery with the supplied USB charging cable. If you try to charge the rechargeable battery with a different battery charger, this might cause serious damage.

## Flying Your Drone

1. Move the throttle/rotate stick to the full down position.

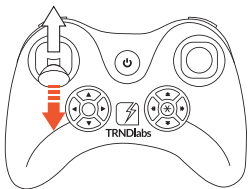

2. Slide the battery into the battery bay on the bottom of the drone. Connect the power cable.

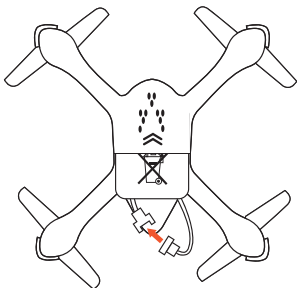

**WARNING**

Immediately after switching it on, place the drone on a flat and level surface. The gyro-system will then set itself automatically.

**3.** Push the power switch of the controller to the ON position. The controller will emit a tone to indicate that binding is complete. At the same time, the LED lights on the drone will start to flash slowly.



**4.** The controller needs to be calibrated after successful binding: move the throttle/rotate stick to the full up position and then push the throttle/rotate stick to the full down position. When the LED on the controller and the LEDs on the drone are all solid (not blinking), the drone is ready to fly.

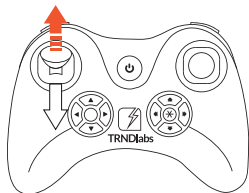

## Flight Controls

Pushing the Throttle/Rotate stick forward will cause the main rotors to spin. The farther you push the stick, the faster the rotors will spin, causing the drone to lift off and gain altitude.

If you notice that the drone moves forwards or to the side without your touching the control sticks, please adjust the trim of the drone as described in "Trimming".

### Throttle Control

To start or to fly higher, push the throttle/rotate stick cautiously forwards. To land or fly lower, push the throttle/rotate stick cautiously backwards.

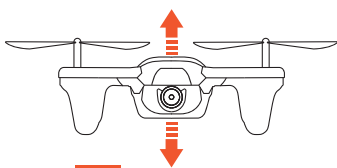
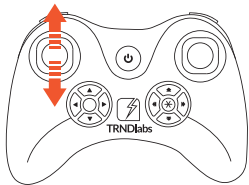

## Direction Control

To fly the drone forwards or backwards, push the direction stick cautiously to forwards or backwards.

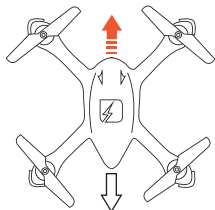
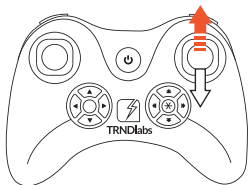

To fly the drone to the left or the right, push the direction stick cautiously to the left or the right.

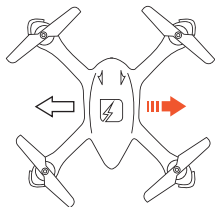
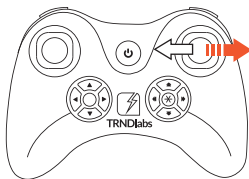

## Rotation Control

To make the drone circle to the left or the right, move the throttle/rotate stick cautiously to the left or the right.

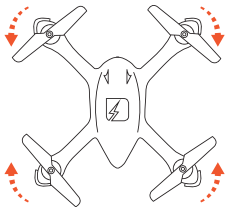
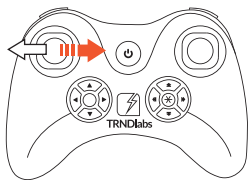

## Sensitivity Control

The drone has two sensitivity settings: beginner and advanced.

Press the sensitivity button in order to change the sensitivity:

1. When the controller emits 1 tone = beginner sensitivity mode.
2. When the controller emits 2 tones = advanced sensitivity mode.

A higher sensitivity makes the drone faster and more responsive.



## Advanced Flight: Performing 360° Flips

The drone can perform 360° front flips, back flips and side flips. Press the flip button, then push the Direction stick forward, backward, right or left at the same time. The drone carries out the flip in the respective direction.



**WARNING**

Do not attempt these stunts until you are able to fly confidently. Choose an area that will provide a soft landing (carpet or grass) and maintain an altitude of at least 10 feet/3 meter to allow room to recover control as you practice flipping the drone.

## Left Side 360° Flip

Press the flip button and push the direction stick to the left at the same time.

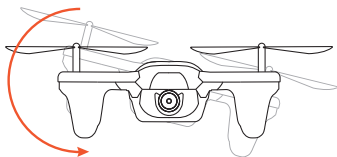
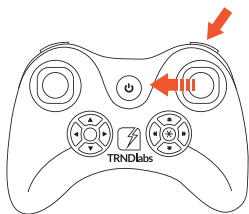

## Right Side 360° Flip

Press the flip button and push the direction stick to the right at the same time.

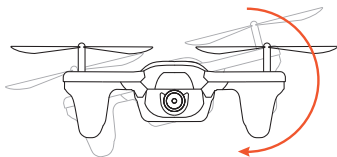
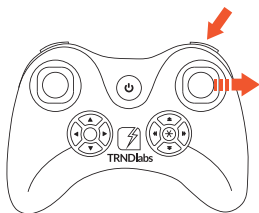

## Forward 360° Flip

Press the flip button and push the direction stick to the right at the same time.

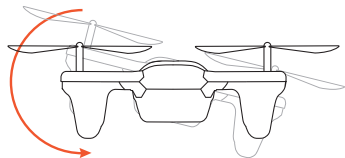
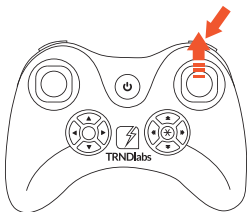



## Backward 360° Flip

Press the flip button and push the direction stick backward at the same time.

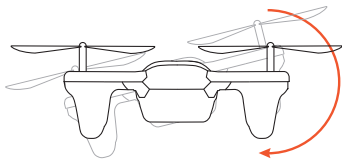
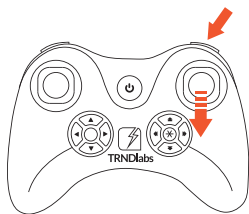

## Trimming

The correct trim is a basic requirement for fault-free flying behavior of your drone.

### Direction Trim

When hovering, if the drone flies forwards or backwards without you moving the direction stick, please proceed as follows:

If the drone moves on its own forwards, press the backward trimmer in steps.  
If the drone moves on its own backwards, press the forward trimmer in steps.

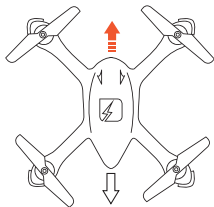
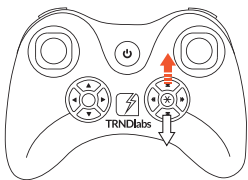

When hovering, if the drone flies to the left or right without you moving the direction stick, please proceed as follows:

If the drone moves on its own sideways to the left, press the right trimmer in steps.

If the drone moves on its own sideways to the right, press the left trimmer in steps.

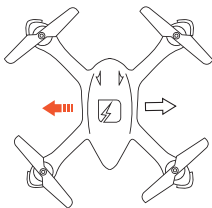
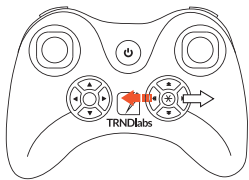

## Rotation Trim

When hovering, if the drone rotates to left or right without you moving the rotation stick, please proceed as follows:

If the drone moves on its own left, press the right trimmer in steps.

If the drone moves on its own right, press the left trimmer in steps.

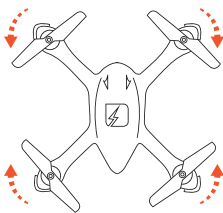
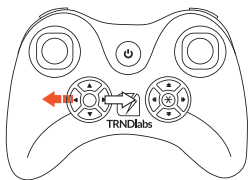

# Calibration

The drone needs to be calibrated if it flies unstable.

1. Place the drone on a flat surface and calibrate throttle (See 4 under "Flying Your Drone")
2. Move the direction stick and the throttle/rotate stick into the lower right corner. Two LED lights on the drone will flash for 2-4 seconds and turn into a constant light meaning that the calibration is successful.

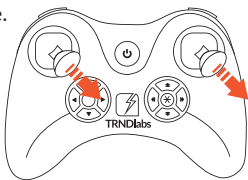

# Video & Photo Function

Fit the microSD Card underneath at the rear in the SD card slot in the drone. Make sure the metal contacts on the SD card are facing in the right direction.

## Recording a Video

Press the video button to begin video-recording. Press the button again to stop recording. While recording, the LED in the SD card slot on the drone flashes red.

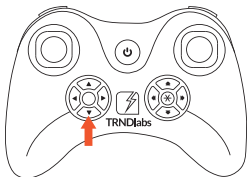
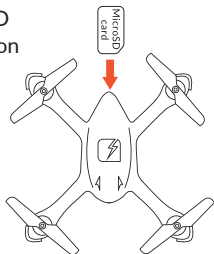

## Taking a Photo

Press the photo button on the controller and the camera takes a photo. The LED in the SD card slot on the drone flashes red after each photo is taken. The small button on the drone is an alternative photo button.

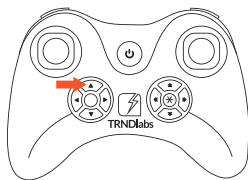

## Playing back videos/viewing photo's

Plug the microSD card into the microSD Card USB Reader and connect this to a computer. You will find the video files e.g. MOVI0000.avi on the SD card in the folder VIDEO. The videos are AVI files. You will find the photo files, e.g. PICT0000.jpg in the folder PHOTO. The photos are JPG files.

## Replacing Rotor Blades

Use a screwdriver to remove the broken rotor. Each rotor is marked with a number. Be sure to note the marking and the tilt angle of the rotor blades.

Front left: marking "2" or "4"

Front right: marking "1" or "3"

Rear left: marking "1" or "3"

Rear right: marking "2" or "4"

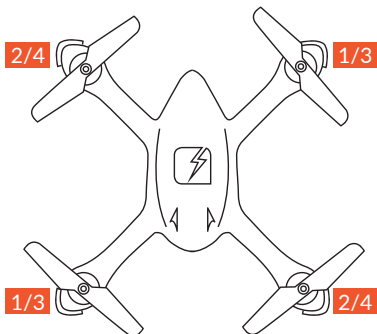



**Problem:** Controller does not work.

**Cause:** The power switch is turned "OFF".



**Solution:** Turn the power switch "ON".

**Cause:** The batteries have been wrongly inserted.

**Solution:** Check if the batteries have been correctly inserted.

**Cause:** The batteries do not have enough power.

**Solution:** Insert new batteries.



**Problem:** The drone cannot be controlled with the controller

**Cause:** The power switch on the controller is turned "OFF".



**Solution:** First turn the power switch on the controller "ON".

**Cause:** The controller is possibly not correctly frequency bound with the receiver on the drone.

**Solution:** Please carry out the binding procedure as described in "Flying Your Drone".



**Problem:** The drone does not lift.

**Cause:** The rotor blades rotate too slowly.



**Solution:** Push the throttle up.

**Cause:** The battery's power is not sufficient.

**Solution:** Charge the battery (see chapter "Getting Started / Charging").



**Problem:** During flight, the drone loses speed and height without any obvious reason.

**Cause:** The battery is too weak.



**Solution:** Charge the battery (see chapter "Getting Started / Charging").



**Problem:** The drone only flies in a circle or turns over on starting.

**Cause:** Rotor blades incorrectly fitted or damaged.



**Solution:** Fit rotor blades/replace rotor blades (see chapter "Replacing Rotor Blades").

# Safety Precautions

- Carefully follow the directions and warnings for this drone and any optional support equipment you may use.
- Never operate your drone with low controller batteries.
- The drone has rotating blades that move at high speed, posing danger of damage and injury. Pilots are responsible for any actions that result in damage or injury from the improper operation of the drone. Choose an adequate flying space without obstacles. Do not operate the drone near buildings, crowds of people, high-voltage power lines, or trees to ensure the safety of yourself, others, and your drone. Wear eye protection when operating your drone and keep your hands, face, hair, loose clothing, and foreign objects away from the rotating blades.
- This drone has small parts that may pose a choking hazard. Keep all small parts and electrical devices out of the reach of children and animals.
- Pets can become excited by radio-controlled drones. Keep pets away from your drone at all times.
- Keep the drone in sight at all times during operation and flight. Discontinue operation immediately if the drone flies out of your field of view.
- Because your drone is controlled by radio, it is subject to radio interference from many sources that are beyond your control. Radio interference can cause momentary losses of radio control; always allow a safety margin in all directions around the drone to prevent collisions.
- When flying indoors, avoid locations with ceiling fans, hanging light fixtures, heating or air conditioning vents, or any other obstacles that may interfere with or damage your drone.
- Keep hands, hair and loose clothing away from the rotors when the power switch is turned on.
- Parental guidance is required for younger users.
- The controller and charger are specifically designed to charge this drone. Never use other charging equipment.
- The drone is NOT intended for use by children under fourteen (14) years old, unless directly supervised by competent adult at all times.
- Regularly examine the drone and controller for any damage to the plugs, enclosure, rotors, battery covers and other parts. In the event of any damage, neither the drone nor the controller should be used.

## Caring For Your Drone

- For best performance, only use fresh Alkaline “AA” batteries in the controller.
- After each crash, inspect your drone for worn or damaged parts.
- The drone automatically switches off if the rotors are unable to rotate. Switch the power to restart the drone.
- When not in use, store your drone in its original packaging with the batteries removed from the controller and drone.
- Always recharge the battery immediately after use to prevent its becoming deep discharged. Please make sure to allow a pause of about 20 minutes between finishing the flight and recharging the battery. Recharge the battery occasionally (suggested every 2-3 months). Failure to treat the battery as described above can lead to its becoming defective.
- When transporting or temporarily storing the rechargeable battery the temperature should be between 5-50°C. If possible, do not store the battery or the drone in a car and do not expose it to direct sunlight. In case the battery is broiled it can be damaged or catch fire.
- Do not submerge the drone or remote control in water. This will damage the electronic components, and could pose a severe risk to the built-in battery.
- Keep the drone and remote away from heat sources.
- To clean, wipe gently with a damp cloth. Avoid use of solvents, as these can damage the plastic components.

## FCC Compliance Information (USA only)

This device complies with part 15 of the FCC Rules. Operation is subject to the following two conditions: (1) This device may not cause harmful interference, and (2) This device must accept any interference received, including interference that may cause undesired operation.



**WARNING**

Modifications not approved by the party responsible for compliance could void user's authority to operate the equipment.

