

VOLTAGE 400V 3P + PE
 POWER 57 kW
 CURRENT 81 A
 AIR CIRCULATION 6800 m³/h [4000 cfm]
 EXHAUST AIR 600 m³/h [350 cfm]

N° Revisione	Descrizione revisione	Data
A00		11/11/2020
Descrizione		
FORNO ELETTRICO POKER 1900 - 1 NAS AND 0 NAS RIT 1,4M ENT 1,4M USC		
Materiale		Peso
		1574,511 kg
		Trattamento superficiale
 Chiossi e Cavazzuti s.r.l. Via Costituzione 50/D 42015 Correggio RE Tel 0522 637224 Fax 0522 732854 www.chiossiecavazzuti.com		Codice 1390073
Progettato da	Data	Revisione
Marco Chiossi	23/02/2012	A00
	Foglio	
	1 / 3	

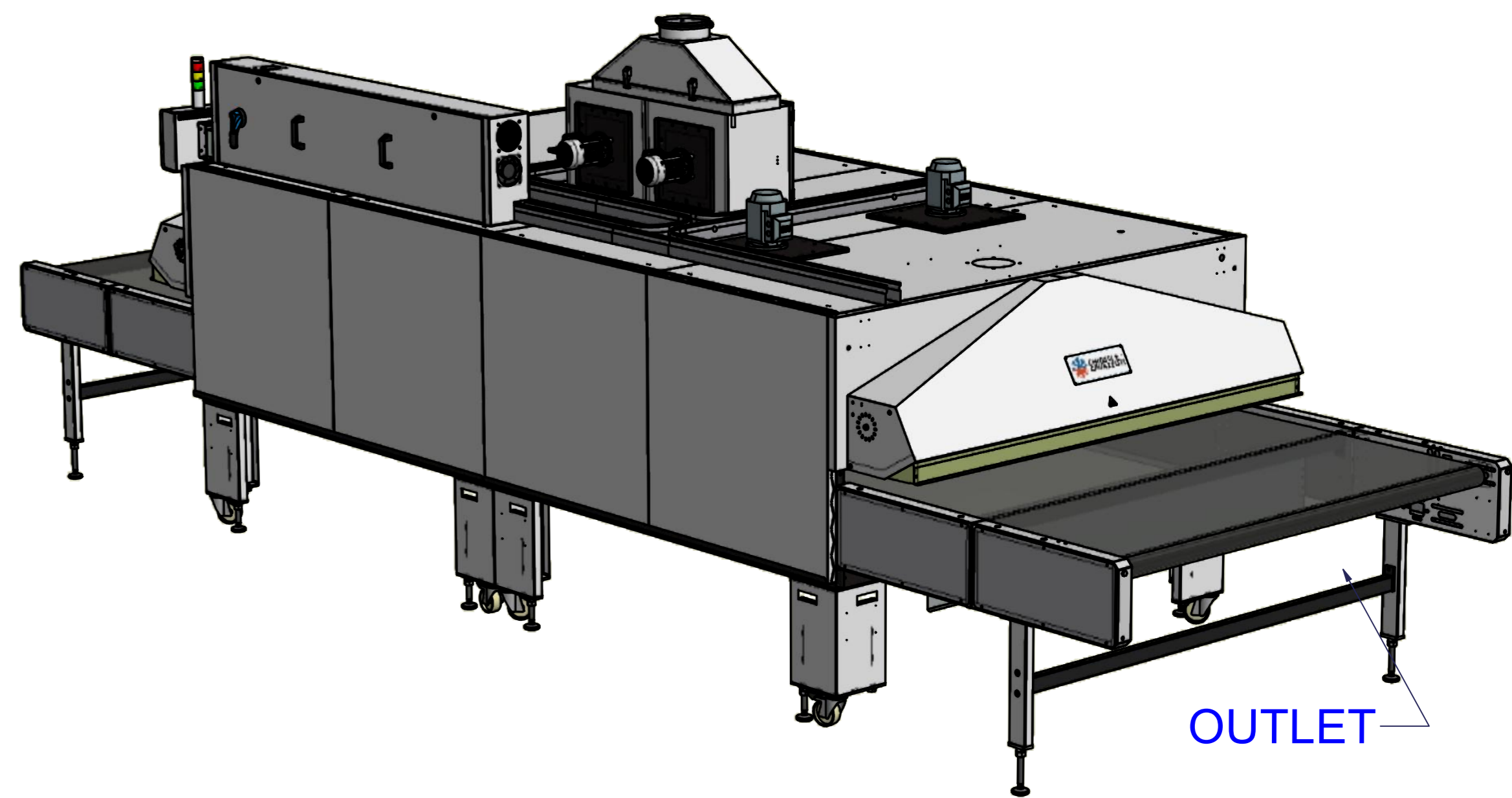
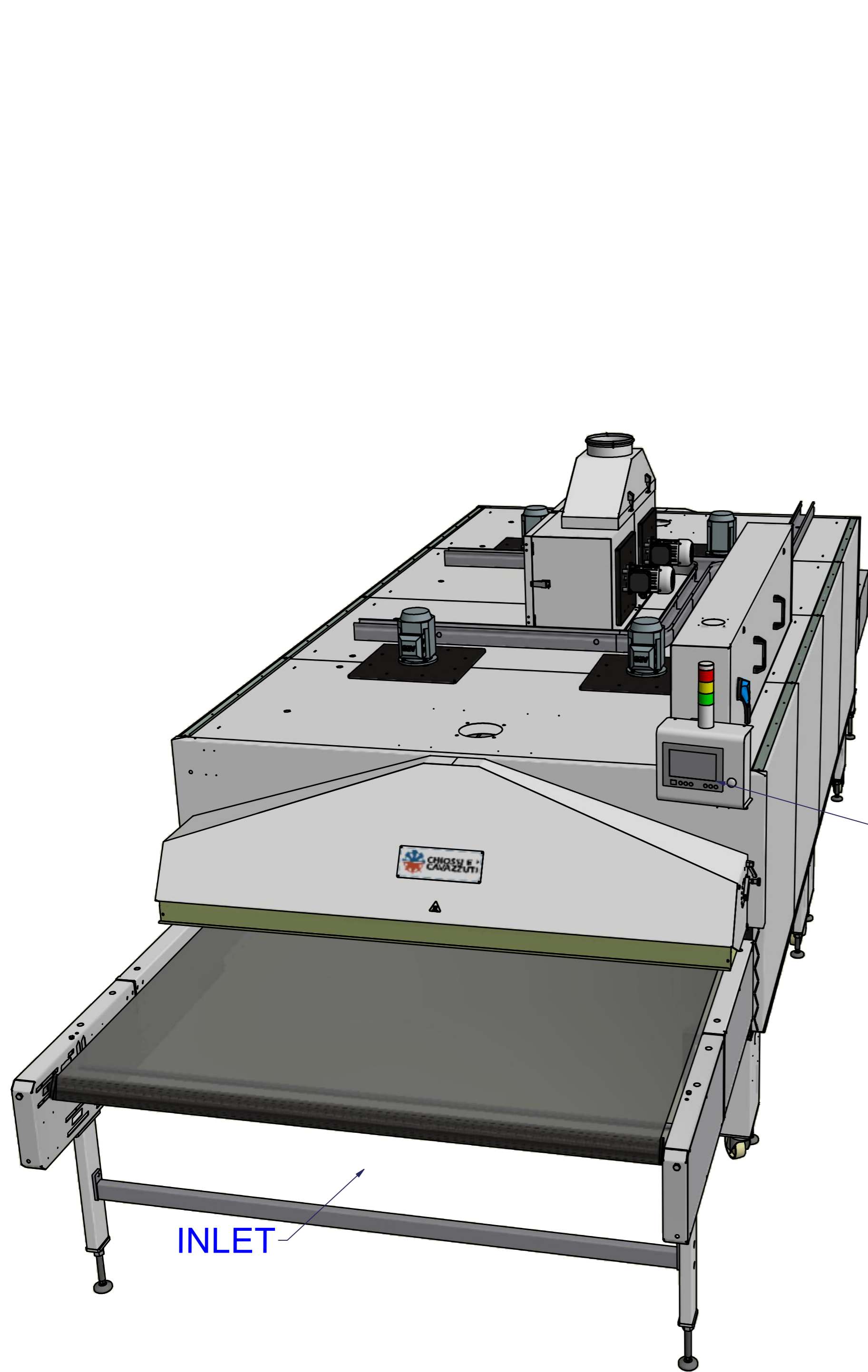

CONTROL PANEL WITH
PLC TOUCH SCREEN

INLET

OUTLET

N° Revisione	Descrizione revisione	Data
A00		11/11/2020
Descrizione		
FORNO ELETTRICO POKER 1900 - 1 NAS AND 0 NAS RIT 1,4M ENT 1,4M USC		
Materiale		Peso
		1574,511 kg
		Trattamento superficiale
 Chiossi e Cavazzuti s.r.l. Via Costituzione 50/D 42015 Correggio RE Tel 0522 637224 Fax 0522 732854 www.chiossicavazzuti.com		Codice 1390073
Progettato da	Data	Revisione
Marco Chiossi	23/02/2012	A00
		Foglio
		2 / 3

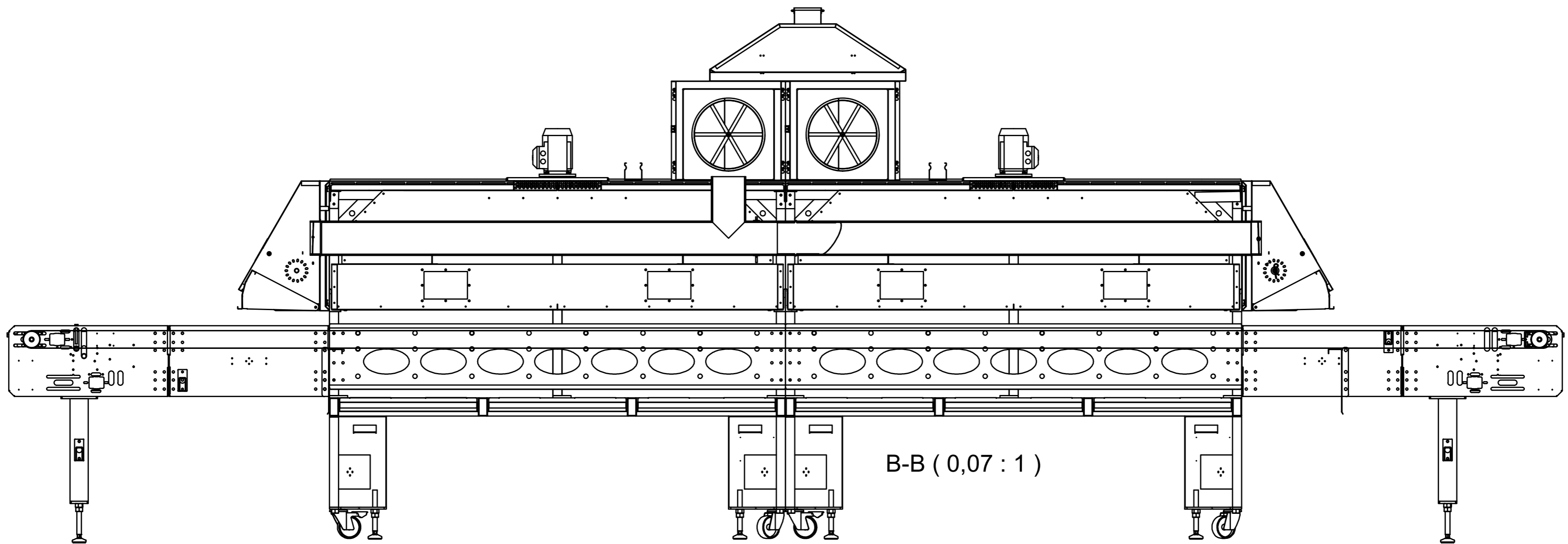

B-B (0,07 : 1)

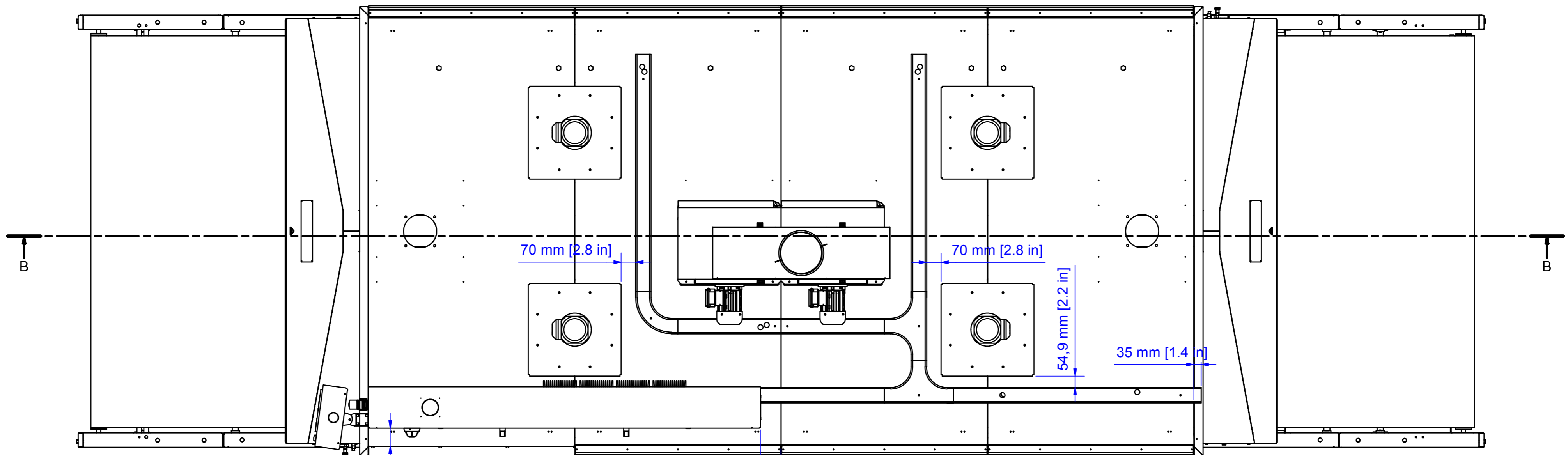

70 mm [2.8 in]

70 mm [2.8 in]

54,9 mm [2.2 in]

35 mm [1.4 in]

100 mm [3.9 in]

88,1 mm [3.5 in]

N° Revisione	Descrizione revisione	Data
A00		11/11/2020
Descrizione FORNO ELETTRICO POKER 1900 - 1 NAS AND 0 NAS RIT 1,4M ENT 1,4M USC		
Materiale		Peso 1574,511 kg
 Chiossi e Cavazzuti s.r.l. Via Costituzione 50/D 42015 Correggio RE Tel 0522 637224 Fax 0522 732854 www.chiossiecavazzuti.com		Codice 1390073
Progettato da Marco Chiossi	Data 23/02/2012	Revisione A00
		Foglio 3 / 3