

OPERATING INSTRUCTIONS

(Translation of the original instructions)



MHM SCREEN PRINTING MACHINE SYNCHROPRINT X-Type plus

©2012-2016 Machines Highest Mechatronic GmbH, Erl, Austria

Preface

Dear Customer,

congratulations and thank you for choosing the MHM Synchronprint X-Type plus Screen Printing Machine. This machine is designed to provide the highest standards of performance and reliability during its guaranteed long operating life. Highly innovative and precise MHM technology provides a combination of the finest built quality along with optimal safety. We trust that these Operating Instructions will assist you in becoming familiar with the safe and efficient operation of the Synchronprint X-Type plus.

Important Note:

Due to our policy of continuous improvement, we reserve the right to change specifications without prior notice. Therefore, certain individual fittings and components may differ slightly from the model detailed in this document. For any further questions regarding your Synchronprint X-Type plus, please contact the MHM service team.

Wishing you every success with your future production.

Machines Highest Mechatronic GmbH

Important Advice Regarding These Operating Instructions

These Operating Instructions form an integral part of the Synchronprint X-Type plus and must be made available to all authorized personnel at all times. No particular sections or pages must be removed from these Operating Instructions, and any missing sections or pages should be replaced immediately, in particular with regard to section “1. Safety Instructions”.

These Operating Instructions are subject to international copyright and may not be reproduced and/or revised without our prior written approval.

©2012-2016 Machines Highest Mechatronic GmbH, Erl, Austria. (All rights reserved).

Published by: Machines Highest Mechatronic GmbH
 Muehlgraben 43a
 A-6343 Erl / AUSTRIA

Contact details: Telephone: +43 (0) 5373 – 76080-18
 Fax: +43 (0) 5373 – 76080-20
 Mobile: +43 (0) 664 – 8151380
 E-mail: service@mhm.at

Erl, February 2016

Content:

Preface.....	2
Important Advice Regarding These Operating Instructions	2
1. Safety Instructions.....	5
1.1. Description of Key Words and Symbols in the Operating Instructions	5
1.2. General Information	6
1.3. Qualification of Operating and Service Staff	6
1.4. Required qualification for operations	7
1.5. Safety Instructions for the Operating Staff.....	8
1.6. Personal Protective Equipment	8
1.7. Additional Risks	9
1.8. Safety Signs on the Machine	10
1.9. Other Valid Rules and Regulations:	10
2. Intended usage of the machine.....	10
3. Data	10
3.1. Serial Number and Year of Manufacture	10
3.2. Dimensions.....	11
3.3. Specifications	11
4. Transportation and packaging	12
4.1. General Notes with Regard to Transportation and Danger Warnings.....	12
4.2. Packaging	12
4.3. Unloading of the crates.....	12
4.4. Packaging material	12
5. Assembly.....	13
5.1. General Assembly Instructions	13
5.2. Positioning of the Synchroprint.....	13
5.3. Ambient Conditions	13
5.4. External supply/Connection ports	14
5.4.1. Electrical Connections	14
5.4.2. Compressed Air.....	14
6. Commissioning the Synchroprint.....	15
7. Design and Operation.....	15
7.1. General Process Description	15
7.2. Overview Machine Parts	16
7.3. Control panel	16
7.4. Safety Devices	17
7.5. Pallets	18
7.6. Foot switch	18
7.7. Main Power Switch	18
7.8. Type Plate.....	19
7.9. Print Stations	19
7.9.1. Overview Print Stations	19
7.9.2. Squeegee Drive Motor	20
7.9.3. Squeegee/Print Arm	20
7.9.4. Screen Adjustment/Micro-Registration	20
7.9.5. Squeegee Stroke Length Adjustment.....	20
7.9.6. Squeegee/Print Arm Lock.....	20
7.9.7. Squeegee carriage speed & pressure controls	20

7.9.8.	Dryer connector.....	21
7.9.9.	Control Keypad	21
7.9.10.	Squeegee Carriage	23
7.10.	Additional equipment	24
7.10.1.	Flash Cure Units	24
7.10.1.	Flocking Devices	25
8.	Danger Zones	26
9.	Control of the Machine	27
9.1.	Starting up and shutting down the Synchroprint	27
9.1.1.	Putting the Machine into Operation	27
9.1.2.	Switching the Machine Off after normal operation	28
9.1.3.	Stopping the Machine in the event of an Emergency	28
9.1.4.	Stopping the Machine in the event of Malfunction.....	29
9.1.5.	Long-term Shutdown	29
9.1.6.	Permanent Shutdown of the Machine	29
9.2.	Configuration of the Control	29
9.3.	Menu Images	30
9.3.1.	Adjust.....	30
9.3.2.	Manually	34
9.3.3.	Automatic.....	36
9.3.4.	BasicSetup.....	38
9.3.5.	Help.....	39
9.4.	Error messages	39
9.5.	Blocked operation.....	40
9.6.	Trouble shooting.....	41
9.6.1.	Error Messages control system	41
9.6.2.	Basic errors (without error message)	42
10.	Maintenance of the Synchroprint	43
11.	Terms of the Guarantee.....	45
12.	Limitation of liability	45
13.	Support, Customer Service and Hotline.....	45

1. Safety Instructions



This section describes the safety instructions for the correct and safe operation of the Synchronprint X-Type plus. In addition, this section also contains references to the European rules and regulations concerning the guarantee of industrial safety along with safety at the workplace. These rules and regulations provide the basis for these operating instructions.

These Operating Instructions include:

1. General safety instructions.
2. Special safety instructions, if they are relevant to a specific section, at the beginning of that respective section.
3. Special safety instructions, if they are important for detailed sequences of operation, before the description of that respective sequence of operation.
4. Indications to read such instructions included in the respective section.

1.1. Description of Key Words and Symbols in the Operating Instructions

In these operating instructions classified key words and symbols are used to identify dangers and items that require special attention. Particular attention is to be paid to the sections marked in this manner, because they contribute to personal safety as well as the prevention of damage to the Synchronprint.

Symbol	Key word	Meaning
 DANGER	DANGER	This symbol indicates possible risk for life.
 CAUTION	CAUTION	This symbol indicates danger of damage to property and/or environment.
 NOTE	NOTE	This symbol indicates useful additional information and operating suggestions.

1.2. General Information

The Synchroprint X-Type plus (hereon named Synchroprint) is built in accordance to all appropriate safety regulations. Owing to its complex design, the Synchroprint must only be operated and maintained by suitably skilled staff.

Installation, operation or maintenance of the Synchroprint by persons who have not been suitably trained, introduced or acquainted with the system and informed regarding the possible dangers may result in:

1. Failure of essential functions of the Synchroprint.
2. Danger to persons through electrical or mechanical actions.
3. Material damage to the Synchroprint.

1.3. Qualification of Operating and Service Staff

‘Qualified personnel’ refers to people who are able to carry out the required procedures and be able to recognize as well as prevent potential risks, as a result of their training and experience. Such personnel should have a good knowledge of any relevant standards, regulations, rules of accident prevention and internal conditions etc.

Every person instructed to perform any operation on the Synchroprint must:



1. Be physically and mentally capable of coping with the respective tasks.
2. Be suitably instructed in operating the Synchroprint.
3. Be familiar with the Operating Instructions, in particular the general safety instructions in the individual sections, and have read and understood them.
4. Be aware of any additional general safety regulations of any local authorities/associations.
5. Be aware of the principles of industrial hygiene and be able to demonstrate them.
6. Be aware of the contents of suppliers’ safety instructions, should they affect his/her area of responsibility.
7. Be aware of any relevant safety devices at the workplace and be able to use them.
8. Be informed regarding the prevention of environmental damage in respect of his/her area of responsibility.
9. Be informed regarding the prevention of material damage in respect of his/her area of responsibility.

If casual workers are employed for assistance work they must be particularly informed regarding existing and potential dangers and instructed accordingly.

1.4. Required qualification for operations

Skill	Assistant	Operating personnel	Maintenance personnel	Service personnel
Colour refill (only at standstill)	X	X	X	X
Unloading substrates	X	X	X	X
Cleaning of the machine (only at standstill)	X	X	X	X
Setting screens	X**	X	X	X
Equip flood and print squeegees	X**	X	X	X
Equip the screens	X**	X	X	X
Adjust squeegees	X**	X	X	X
Clean of the screens in clean mode	X**	X	X	X
Equip machine with dryer or changing the position	X**	X	X	X
Applying substrates		X	X	X
Enable and disable printing heads		X	X	X
Enable and disable of dryer		X	X	X
Start of all printing processes and adjustment work		X	X	X
Activities at the maintenance unit		X	X	X
Lubricate of the machine		X	X	X
Shutting down the machine		X	X	X
Long-term shutdown			X	X
Permanent shutdown of the machine			X	X
Maintenance and repairs at the pneumatically system			X*	X
Maintenance and repairs at the electrical system			X*	X
Maintenance and repairs at the mechanical system			X*	X
Maintenance and repairs at additional units			X*	X
Maintenance and repairs at the electronically system				X
Maintenance and repairs at the safety system				X
<p>* only with the required qualification</p> <p>** only together with the operating personnel</p>				

1.5. Safety Instructions for the Operating Staff





 DANGER	All cabinets and covers on the Synchronprint must always be kept closed. Open cabinets and covers are extremely dangerous as live electrical components are accessible.
	Mechanical or electrical failures must only be repaired by an MHM authorized/approved technician.
	On every occasion, the operator should check the correct functioning of the safety devices (Emergency STOP), before commencing use of the Synchronprint.
	No modifications to any part of the machine or its assembly system that may adversely affect safety must be carried out without the prior approval of MHM.
	Program modifications in the control program and changes of settings which may affect the Synchronprint's operation should only be carried out by an MHM authorized/approved technician.
 CAUTION	All working spaces, passageways, escape and emergency routes and exits must be kept clear.
	No tools or other objects must be kept or left in the area of the machine.
	Any modifications or changes to the Synchronprint's settings should only be carried out by an MHM authorized/approved technician.
	Always wear protective gloves and safety goggles during cleaning work, in particular when using solvents!
	Any remains of potentially harmful substances should be disposed of according to the legal requirements of the country or state in which the Synchronprint is operated.
 NOTE	All accessories for service and maintenance work (e.g. cleaning agents) must be collected in suitable containers and disposed of according to any relevant regulations.

1.6. Personal Protective Equipment

Personal protective equipment must be used at work. This equipment comprises close-fitting working clothes with tight sleeves and high tearing resistance without any protruding parts. These features prevent operators from getting caught by moving machine parts.



1.7. Additional Risks

Even though the Synchroprint has been designed and built according to the most stringent safety criteria, as with all machinery we have to anticipate certain additional risks, which are detailed below:

Danger	Description	Behavior/Action
<p>Electrical threats: Indirect contact (in case of defect)</p> 	<p>Danger of life-threatening electrical shock by indirect contact with defective parts carrying voltage (in particular in case of defective insulation).</p>	<p>Switch off the machine with the main switch and EMERGENCY STOP facilities. Isolate the mains supply.</p>
<p>Mechanical threats: Crushing</p> 	<p>Crushing of parts of the body - in particular arms and hands.</p>	<p>Be aware of moving parts whilst operating the machine. Wear protective clothing at all times.</p>
<p>Mechanical threats: Getting caught or trapped</p> 	<p>Danger through moving parts (linear or rotary drive systems).</p>	<p>Danger in reaching into, under or over the machine. Only reach into the machine from the indicated points. Wear suitably fitting clothing, particularly in the area of the arms.</p>
<p>Mechanical threats: Slipping, stumbling and falling</p> 	<p>Danger of falling (e.g. obstacles on the floor).</p>	<p>The floor area around the machine must be kept free from any obstacles.</p>
<p>Danger through contact with or inhaling of substances</p> 	<p>Danger through contact with or inhaling substances or materials with harmful or toxic effects.</p>	<p>Observe the safety instructions for handling such substances.</p>

1.8. Safety Signs on the Machine

The following safety signs are attached to the corresponding points of the machine:

Danger	Description	Location
	Warning against squashing of parts of the body, in particular arms or hands.	At squeegee carriages.
	Warning of dangerous voltage.	At current-carrying parts of the machine with 230/400VAC.

The adhesive labels must be replaced if illegible (due to dirt or damage).

1.9. Other Valid Rules and Regulations:

The customer must comply with all regulations applicable in the country where the machine is located.

2. Intended usage of the machine

The machine is intended for the printing of substrates (usually textiles such as T-shirts, but also paper or similar materials) by means of screen printing. The substrates are conveyed by means of the “carrousel system”. With the use of optional accessories the substrate can also be dried or treated with other finishing techniques (e.g. flocking).



Any other use of the machine than described above may result in danger to persons or material damage and is therefore forbidden.

3. Data

This section details the Synchroprint technical specifications.



NOTE

NB: As our policy is one of continuous improvement, we reserve the right to change specifications without prior notice.

3.1. Serial Number and Year of Manufacture

Serial number and year of manufacture are indicated on the machine’s type plate.

3.2. Dimensions

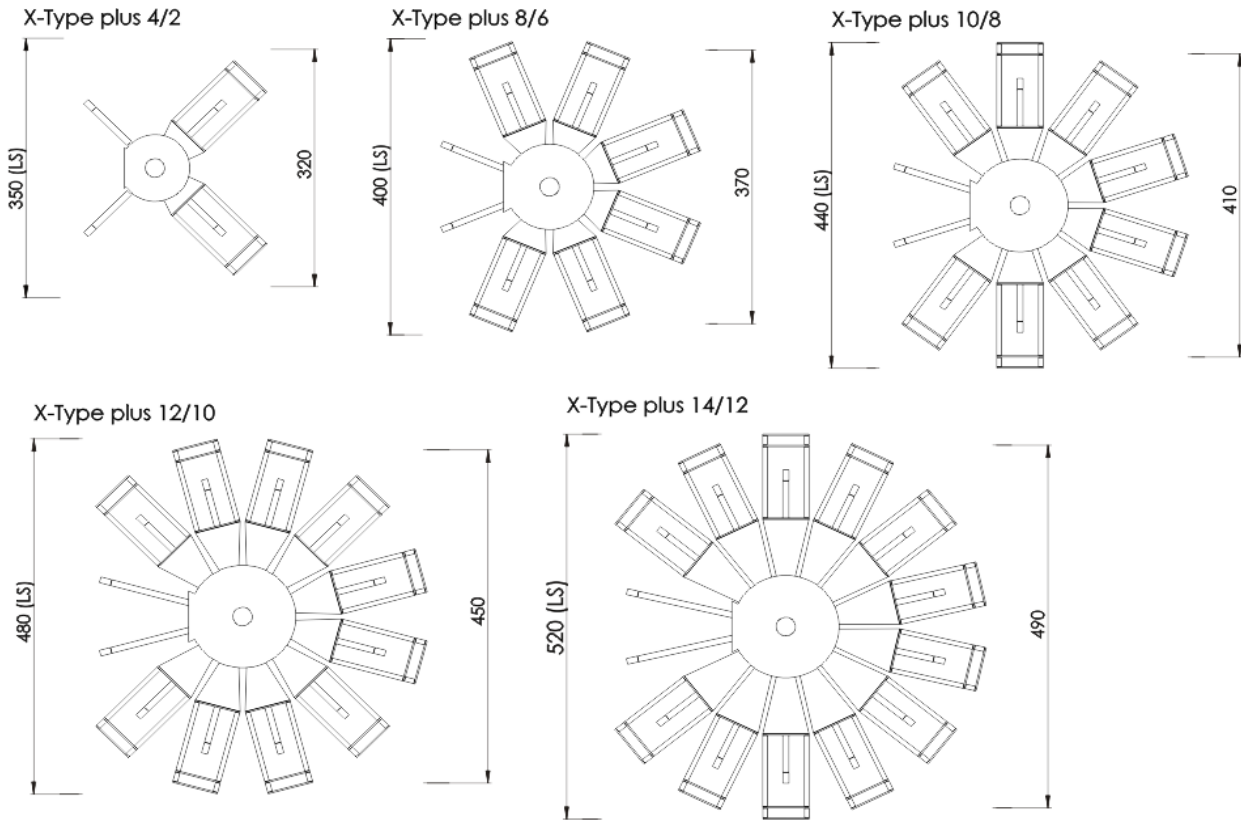

3.3. Specifications

Specifications X-Type plus	SPXC 04	SPXC 08	SPCX 10	SPXC 12	SPXC 14
number of pallets	4	8	10	12	14
max. number of printstations / colors	3	6	8	10	12
max. image area (standard version)	43 x 50 cm (17 x 19,5")				
max. image area (LS version)	43 x 55 cm (17 x 21,5")				
max. frame size (standard version)	60 x 80 cm (23 x 31")				
max. frame size (LS version)	66 x 92 cm (26 x 36")				
overall diameter	320cm 126"	370cm 146"	410cm 161,5"	450cm 177"	490cm 193"
overall diameter LS version	350cm 137,8"	400cm 157,5"	440cm 173,5"	480cm 189"	520cm 205"
Machine weight (standard version) [kg]	1100	1700	1850	2000	2300
Machine weight (LS version) [kg]	1150	1750	1900	2050	2350
electrical supply	1 ph. ~ 200/240V AC, 50/60Hz (+/- 5%)				
connected load (indexer)	1,6 kVA				
connected load (per printstation)	0,4 kVA				
∅ power consumption [kWh]	0,58	0,8	0,95	1,1	1,25
air pressure (minimum)	7 bar / 100 PSI (filtered, dry air only)				
∅ air consumption (l/min)	130	220	280	340	400

4. Transportation and packaging

This section provides an overview of the proper transportation of the Synchronprint.

4.1. General Notes with Regard to Transportation and Danger Warnings



Danger of falling objects!

The following instructions must be observed

1. Never stand or walk under hanging loads!
2. Transportation must be carried out by qualified staff observing all safety instructions.
3. The Synchronprint must only be lifted at the dedicated lifting points.
4. Only the lifting/handling devices and equipment indicated in this document must be used for the movement of the Synchronprint. Non-compliance may lead to serious damage of the Synchronprint and result in cancellation of the warranty.



Upon delivery of the Synchronprint the consignment must be examined for external damage immediately. In the case of any damages, they must be documented and reported to Machines Highest Mechatronic GmbH within 24 hours.

4.2. Packaging

The Synchronprint will be packed and delivered in several wooden crates. The crates' exact number, weight and dimensions will vary slightly according to each model/type of machine. Contact customer service for more information about individual orders.

4.3. Unloading of the crates

The Synchronprint is to be unloaded by the customer. A forklift truck with adequate fork length and lifting capacity (see 4.2 Packaging) will be required.



Danger of mechanical damage!

The Synchronprint must be lifted carefully and only at the dedicated lifting points at the middle of the base unit. Lifting the Synchronprint at/by any other point, especially the turntables, may result in serious damage. Be sure to maintain an adequate and safe distance during lifting.

4.4. Packaging material

After unpacking the machine, the packaging material must be disposed of according to local regulations.

5. Assembly

This section describes the external supply/connection ports of the Synchroprint and the points to be observed during assembly.

5.1. General Assembly Instructions



The Synchroprint must only be installed / assembled by an authorized MHM service technician or by an authorized service technician from an official MHM dealer/agent. Any assembly/installation by any third party not listed above will result in immediate cancellation of the warranty.

The customer should have a minimum of two persons available to assist the technician with the installation and assembly of the machine.

5.2. Positioning of the Synchroprint

The machine must be mounted on a bed with sufficient load-bearing capacity. In case of doubt this capacity has to be examined by a structural engineer.

In order to guarantee perfect installation and smooth operation of the Synchroprint, the machine must be installed at a sufficient distance from adjacent elements of the building (walls, columns, etc.) and/or other machines. The distance required in each case depends on the screen size, and must be chosen so as to allow the operator to replace the screens without any problems. The dimensions of the respective machine are indicated in Chapter “3 Data”.

5.3. Ambient Conditions

For the electrical equipment on the Synchroprint, ambient conditions according to standard IEC 60204 “Electrical Equipment of Industrial Machines” should be observed.

The following points should be observed in order to achieve efficient running and an optimum level of production with the Synchroprint:

1. The premises, where the Synchroprint is to be operated, must be kept clean, dry and well-aired.
2. The ambient temperature must not fall below +5° C or exceed +45° C.
3. Relative air humidity must not exceed 80 %.
4. The mains supply must not exceed or fall below a tolerance of +/- 5 % of the required voltage for the Synchroprint. If this voltage stability cannot be guaranteed, the customer must install a constant-voltage regulator to protect the Synchroprint against such fluctuations.
5. The compressed air must be clean, filtered and dry (class 1:4:1 according ISO8573-1:2010).
6. Compressed air supply must be sufficient in terms of pressure, volume and consistency.
7. Electricity supply should be sufficient with adequate fuse protection.
8. Maximum installation altitude is 2000m above sea level.

5.4. External supply/Connection ports

Connections for compressed air and mains electricity are located on the base unit of the Synchroprint as standard. Overhead supply connections may be ordered optionally but only at time of order, to enable supplies to enter the machine from above, through the centre column.



Danger of tripping over!
 In case of laying supply lines on the floor, it is necessary to attach step covers.

5.4.1. Electrical Connections



Risk of electric shock!
 Please observe the general safety regulations for electrical connections when connecting the mains supply to the Synchroprint. Avoid any contact with live components.

The electrical connections must be designed as follows:

Description	Requirement/Value
Supply voltage	1 x 200-240 V
Supply frequency	50/60 Hz ±5 %
Connected load	1.6 kVA + (0.4 kVA x „number of print heads“) (= “power for indexer main drive” + “power per print head” x “number of print heads”)



All flash cure units must be supplied through a separate/independent connection. Please observe the precise technical data from the flash cure unit specification sheet.

5.4.2. Compressed Air

Description	X-Type plus				
	4/2	8/6	10/8	12/10	14/12
Max. air consumption (l/min)	130	220	280	340	400
Air pressure (minimum)	7 bar / 100 PSI				
Air quality	filtered, dry air supply only (class 1:4:1 according ISO8573-1:2010)				

6. Commissioning the Synchroprint



NOTE

Before starting the machine, mains connection and compressed-air supply must be checked and, if necessary, established according to the instructions.



NOTE

Initial start-up of the Synchroprint should only be carried out by an authorised MHM service engineer or by an approved technician from an official MHM dealer/agent.

After the initial start-up of the machine, commissioning is to be completed in the presence of the authorized technician along with any persons authorized on the part of the customer. During this initial start-up and commissioning, all tasks carried out by the MHM service engineer or the technicians of an authorized dealer are recorded.



NOTE

Any defects or complaints must be brought to the attention of the authorized technician, documented in writing and recorded immediately on the service technician's installation/job sheet.

This installation/job sheet must be clearly signed by both parties, stating the date and location of the Synchroprint and will be legally binding hereon after.

7. Design and Operation

This section describes design and operation and indicates the individual assemblies.

7.1. General Process Description

The operator applies a substrate (usually a T-shirt or paper) to the pallets at the locating surface. Textiles will be fixed in position by means of the spray adhesive applied to the pallets beforehand. For paper a special vacuum model is necessary to hold the substrate on the pallet by means of negative pressure. Subsequently, the carousel moves the substrate to the first print station, where the substrate is printed by means of screen printing or treated with optional accessories. Subsequently, the substrate moves to the second station, where it is treated again, before the process continues with all other stations. Finally, the substrate arrives at the unloading point, where an operator takes it from the machine for further processing.

7.2. Overview Machine Parts

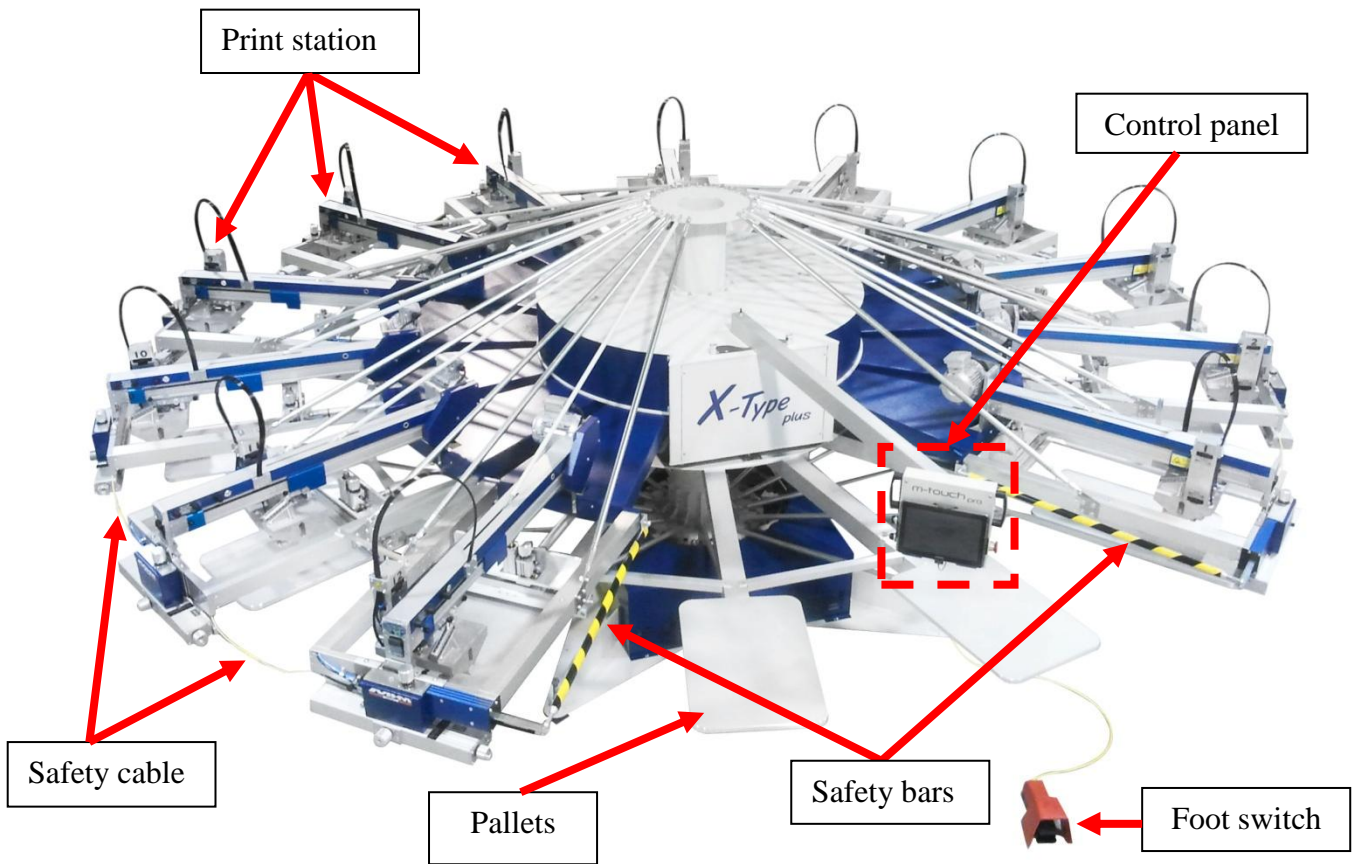

7.3. Control panel

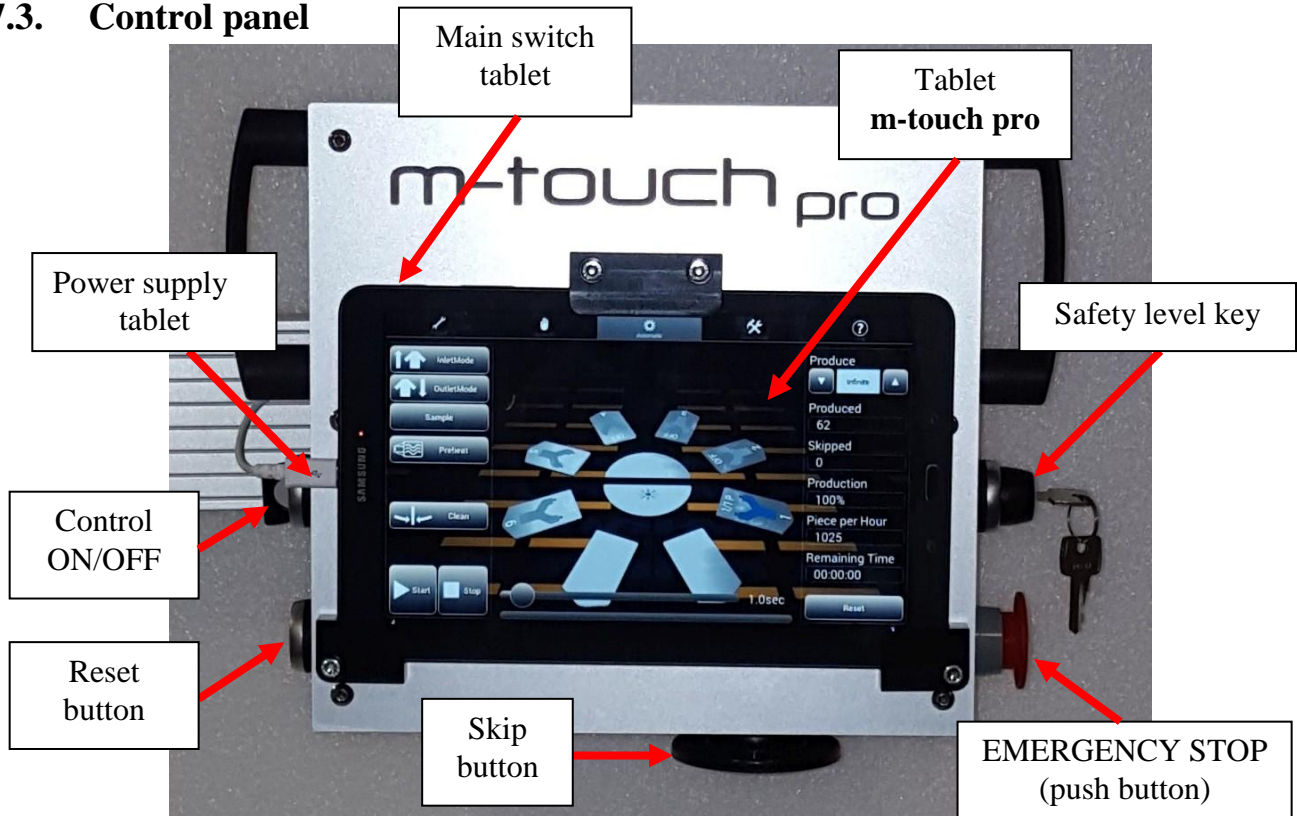

The main control panel includes the following features:

Machine feature	Description
Tablet m-touch pro	The tablet PC is used to control the main operating features of the Synchroprint. Touching (tapping) the command buttons displayed on the screen will operate various individual functions of the machine. You will find a detailed description of all functions in section “9 Control of the Machine”.
Main switch tablet	Use “Main switch tablet” to switch the tablet on, off or to put it into idle state. When the unit is on, push shortly to change into idle state. After a longer push a menu will be displayed where the unit can be switched off completely. To start the tablet a short push is enough. The handling is similar to modern Smartphones.
Control ON/OFF	“Control ON/OFF” is used to switch the control power supply which supplies all control components inclusive the tablet. To switch off the main power use the main power switch.
EMERGENCY STOP (push button)	The EMERGENCY STOP push button is part of the safety facility. See section 7.4 Safety Devices.
Skip button	Press the Skip-Button when substrate is not applied in a correct way. In this case the respective print station will not start to work and the substrate will not be printed. The print process at other stations and pallets will not be interrupted.
Reset button	To cancel a safety device shutdown first press the ERROR RESET PUSH BUTTON and clear error message on tablet afterwards.
Safety level key	In operating mode ADJUST an automatic error resetting can be activated with the safety level key; this is needed to adjust the machine in case of certain adjustment procedures. This can be done by switching the safety level key to position 1, in normal operation the key must be in position 0. Only properly trained and appropriately qualified personnel should use this function. The quick stop function of the turn table is active all the time. Print and flood strokes can also be made at active error situations, while a turntable index is prevented.
Power supply tablet	To load the battery of the tablet the power supply must be connected. To prevent battery from discharging, press “Main switch tablet” shortly to put tablet into idle mode. If this is not done, the tablet must be restarted the next day.

7.4. Safety Devices

The safety devices serve as emergency stop facilities to avoid accidents and to guarantee safe operation of the machine. The Synchroprint has the following safety devices:

Safety device	Description
EMERGENCY STOP (push button)	Push button located at the main control panel. In case of emergency, pressing the EMERGENCY STOP will stop all movements of the machine. The function of the push button is cancelled by unlocking the switch (turning it to the right).
Safety bars	Yellow/black bars located at the right and the left of the ‘load/unload’ area. Pressing any one of these bars will result in an immediate EMERGENCY STOP of the machine. The location of these bars ensures that the EMERGENCY STOP function is activated automatically should a person become trapped between print station and pallet.
Safety cable	The safety cable blocks the danger zone between two print stations. When the cable is disconnected, an immediate EMERGENCY STOP is activated.



These safety devices must not be used to switch off the machine under normal operation. Any EMERGENCY STOP presents an exceptional loading to the servo-motor and transmission etc. Excessive use will result in damage to the machine along with subsequent cancellation of the warranty.

7.5. Pallets

The substrates must be applied on the pallets. Depending on the substrate size, different pallets must be used. By default pallets with format 40x80cm made of aluminum in honeycomb structure and a thickness of 17mm are used. The maximum allowed pallet weight is 4kg.



Exceeding the maximum allowed weight of the pallets would increase the dynamic load to the machine and can cause material damage. The maximum weight of the pallets must be observed.



Only pallets provided by MHM must be used for production.

7.6. Foot switch

The foot switch is used to start an index movement when machine runs in manual mode. In automatic mode the index movement can be blocked.

7.7. Main Power Switch

The main power switch is mounted at the machine’s basic frame. It disconnects the machine from the main supply voltage immediately.

7.8. Type Plate

The type plate with type, serial number, year of manufacture, mains voltage, mains frequency, connected load and CE symbol is located on the machine base.

7.9. Print Stations

7.9.1. Overview Print Stations

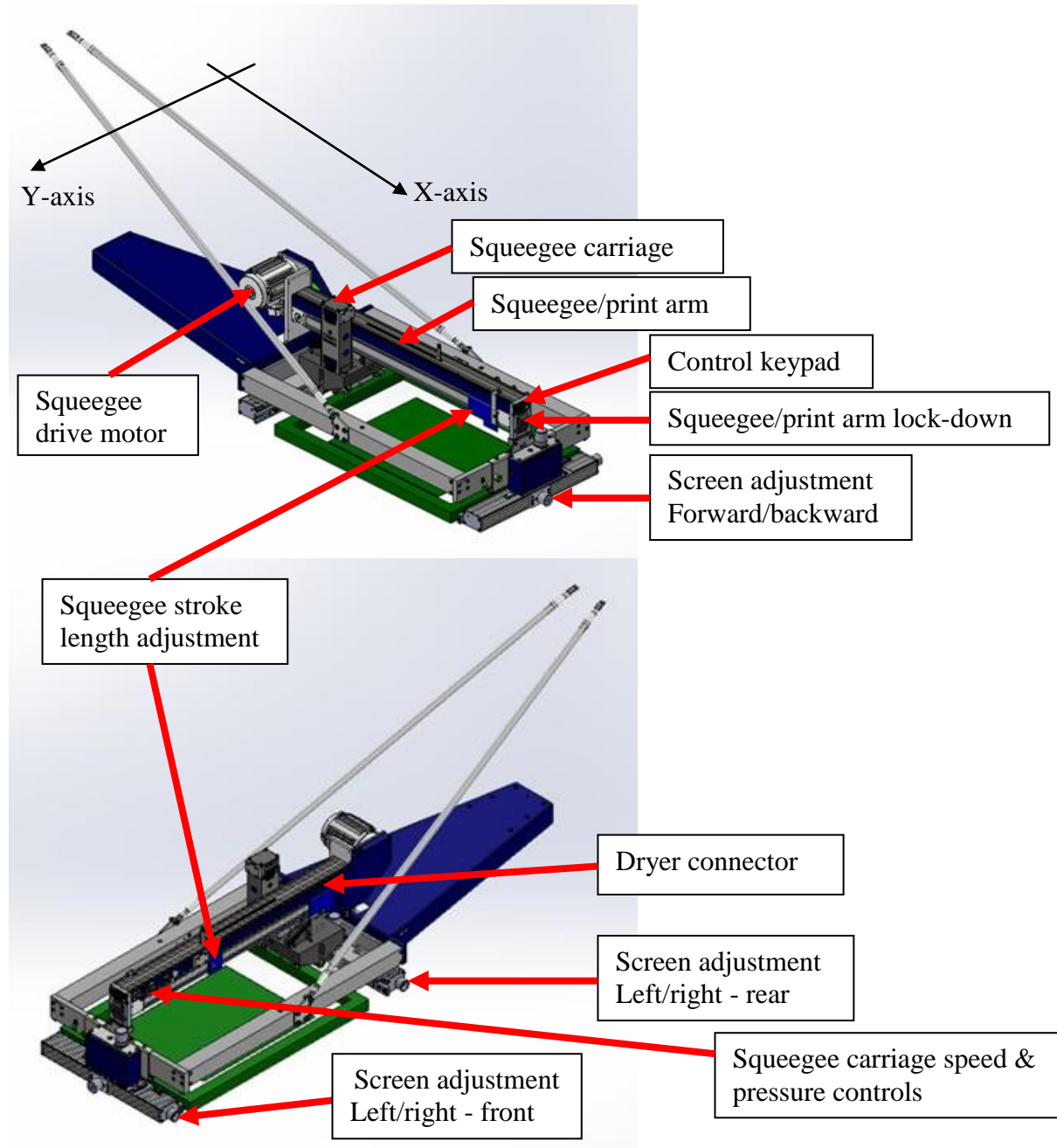

The print stations are used for printing individual colors onto textiles/garments. The X-Type plus may be ordered with a maximum of up to 12 print stations. The following sections include a detailed description of the individual components.

7.9.2. Squeegee Drive Motor

The squeegee/print arm motor is used to drive the squeegee carriage back and forth, precisely controlled by the frequency converter.

7.9.3. Squeegee/Print Arm

The squeegee carriage, squeegee stroke length adjustment, control keypad and control knobs for the squeegee carriage speed & pressure are all located on the squeegee arm.

7.9.4. Screen Adjustment/Micro-Registration

The screen adjustment/micro-registration is used for the precise positioning of the screens. Each screen may be positioned forwards/backwards by means of a single handwheel adjuster located at the front of each individual print station. For left/right adjustment there are two handwheel adjusters located at the front and rear of each individual print station. Adjustment is free from play and self-locking, therefore no additional clamping is required.

7.9.5. Squeegee Stroke Length Adjustment

The squeegee stroke length adjustment may be used to adjust the precise travel of the squeegee carriage. There are individual sensors on each print station to adjust the front and rear positions. Minimizing the travel of the squeegee carriage helps to reduce printing times and increase production.

7.9.6. Squeegee/Print Arm Lock

Pressing the squeegee/print arm lock moves the entire squeegee/print arm upwards, providing unobstructed access to the screens.

7.9.7. Squeegee carriage speed & pressure controls

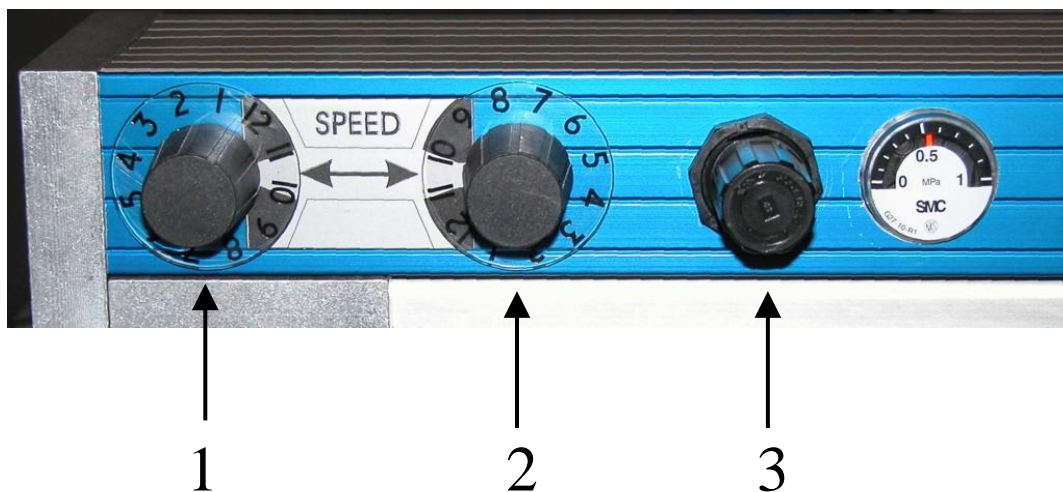

- 1... Adjustment for squeegee carriage speed forwards
- 2... Adjustment for squeegee carriage speed backwards
- 3... Adjustment for squeegee pressure (with clear display gauge)

7.9.8. Dryer connector

The dryer connector is used to control external units like intermediate dryers or flock units. When the machine detects a 24-V signal at pin number 6 “Auto detect”, the dryer is detected automatically. The drier is started with a 24-V signal on pin 5. The duration of the drying process can be controlled internally through the control or externally through the drier. In case of external control, a 24-V signal on pin 2 is required as a ready message. The system detects the positive edge of the complete signal, no continuous complete signal is allowed.

The following pin assignment is given:

- Pin 2: IN ready signal
- Pin 3: GND
- Pin 5: OUT run/start signal
- Pin 6: Auto detect
- Pin 7: +24 V

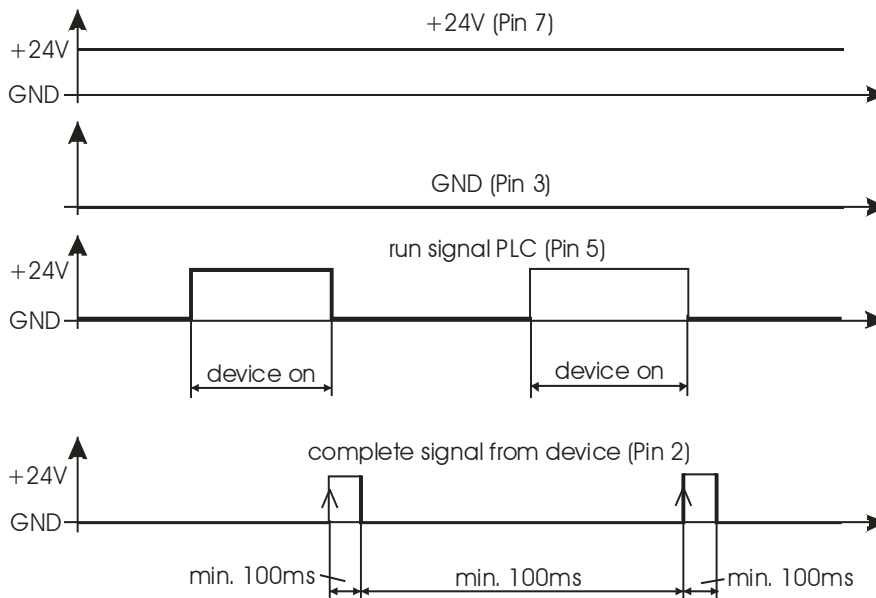









7.9.9. Control Keypad



The control keypad is used to operate various functions without having to return to the main control panel. Control of the machine through the control keypad is only possible when in the ‘ADJUST’ mode.

The following functions are available from the control keypad:

Key	Function
	Pressing and holding 'ADJUST' on the keypad (approx. 3 sec.) puts the machine in the 'ADJUST' mode.
	The 'LOCK' key is used to lock/unlock the screen pneumatically.
	Pressing the 'SQUEEGEE CARRIAGE MOVEMENT' key moves the squeegee carriage once, either forwards or backwards depending on its initial position.
	The 'RAISE/LOWER' key raises or lowers all print stations depending on their initial position.
	Pressing the 'ADJUST' and the 'SQUEEGEE CARRIAGE MOVEMENT' keys simultaneously starts one complete cycle of the respective print station. (<i>e.g. flood/machine lower/print/machine raise</i>)
	Pressing the 'ADJUST' and the 'INDEX LEFT' keys simultaneously will move the turntable one position/index to the left.
	Pressing the 'ADJUST' and the 'INDEX RIGHT' keys simultaneously will move the turntable one position/index to the right.
	Pressing the 'INDEX LEFT' and the 'INDEX RIGHT' keys simultaneously initiates a 'half-index' or cleaning mode, particularly useful for cleaning the screens. In this mode the turntable is rotated backwards in between the print stations, enabling the operator to reach underneath the screens with minimal obstruction. Pressing the two keys again will return the turntable to its original position.

7.9.10. Squeegee Carriage

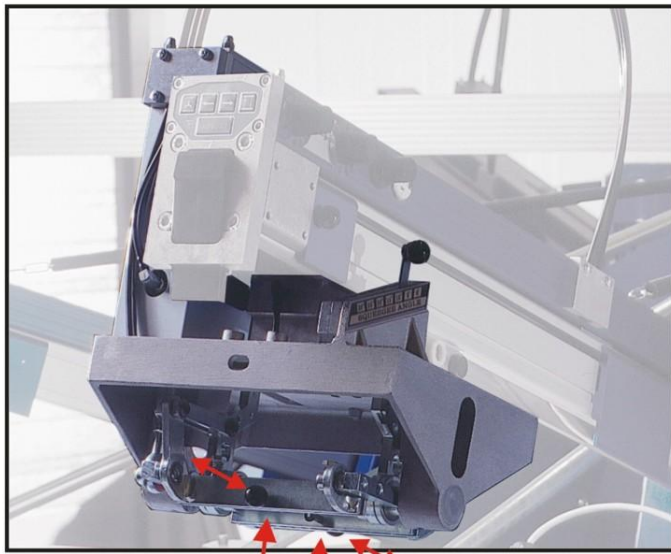

The squeegee carriage is equipped with two squeegees. Pulling the black 'quick release' knob (*pic. opposite*) will release the respective squeegee. Make sure that these locking knobs engage fully when loading the squeegee. The maximum permitted squeegee width must be observed.

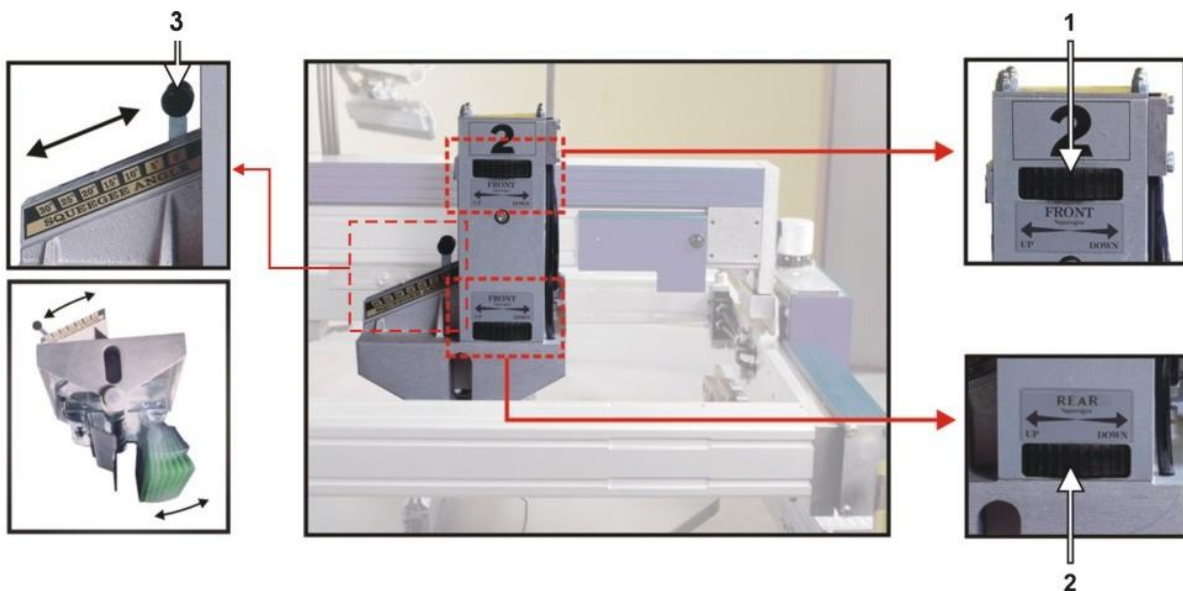
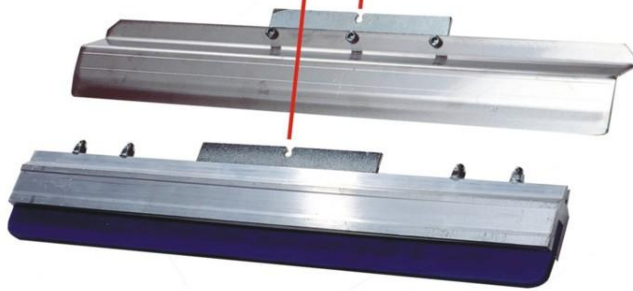

Squeegee height may be adjusted individually with the handwheels (*pic. 1 + 2*). Squeegee angle may also be adjusted individually by the sliding levers (*pic. 3*). Squeegee pressure may be adjusted with an adjusting knob located on the squeegee arm (see section 7.9.7 *Squeegee carriage speed & pressure controls*).

7.10. Additional equipment

7.10.1. Flash Cure Units



Flash cure units may be installed into either an empty station or a print station. The flash cure unit must be powered by a separate supply, which should comply with the electrical data supplied by the manufacturer (*see data sheet for flash cure units*). To control the unit the dryer must be connected with the dryer connector of the station.



When connecting the flash cure unit make absolutely sure to keep all cables away from any moving parts (especially the turntable/moving pallets etc). Failure to do so may result in damage to the cable along with serious electrical damage to the flash cure unit and machinery.

Procedure for the installation of a flash cure unit into a print station



When connecting the dryer with the dryer connector of the station the unit will be identified automatically and the print function of the station will be switched off. Be sure that every dryer which is installed into a print station is connected with the dryer connector.

An empty/blank screen frame (without mesh) should be loaded in the position of a normal screen in order to push and hold the screen holders away from the heated area to prevent any damage. Move the squeegee carriage backward to its rear end position before installing the flash cure unit into the print station. Subsequently, the electrical supply and data lead should be connected.



The pallets are only warranted to withstand temperatures of up to a maximum of 150° C. Exceeding this temperature will result in the cancellation of warranty for the pallets.

7.10.1. Flocking Devices



The high voltage of several thousand volts required for the flocking process represents a great threat for man and machine. That's why only specially qualified workers familiar with all potential risks are allowed to operate flocking devices. Before starting the machine, please read the manual of the flocking device's manufacturer and observe all safety regulations. Any noncompliance may endanger people and result in material damage to machines.

During the flocking process high voltage is used to generate a magnetic field, which aligns the flock fibers and transfers them onto the substrate. Installation and selection/control are similar to those of intermediate driers.



In case of any spark-over due to the high voltages applied, the electromagnetic interference arising from them may affect, or in extreme cases even destroy, the printing machine and other components.

Therefore, the following protective equipment is prescribed for flocking devices:

1. Optimal grounding of all machine components:
All machine parts must be connected using adequately dimensioned cables. In addition to the earth connection via the main lead, the machine must also be connected to the building's grounding.
2. Installation of a metal drier socket.
3. Use of a signal cable with good EMC- characteristics (07-0-0-0226-0).
4. Shielding of the sensor cable through a screening braiding (30-1-1-0006-0).
5. Installation of screening plates in front of the motion trackers (02-1-6-0024-0).
6. Attenuation of drier as well as position signals in the squeegee/print arm by means of ferrites (30-1-1-0005-0, also known as suppressor chokes).

Points 2-6 must be applied to all flocking stations as well as both adjacent stations. A set with all needed parts for one print station can be ordered with part number 20-0-0-9160-0. Please find detailed instructions in the file "package of measures for the use of flocking devices.pdf".

8. Danger Zones

Danger zones are the areas of the machine which during operation involve a certain risk for people owing to mechanical movement. This comprises all areas of the machine which involve rotary motion, clamping or other movements.

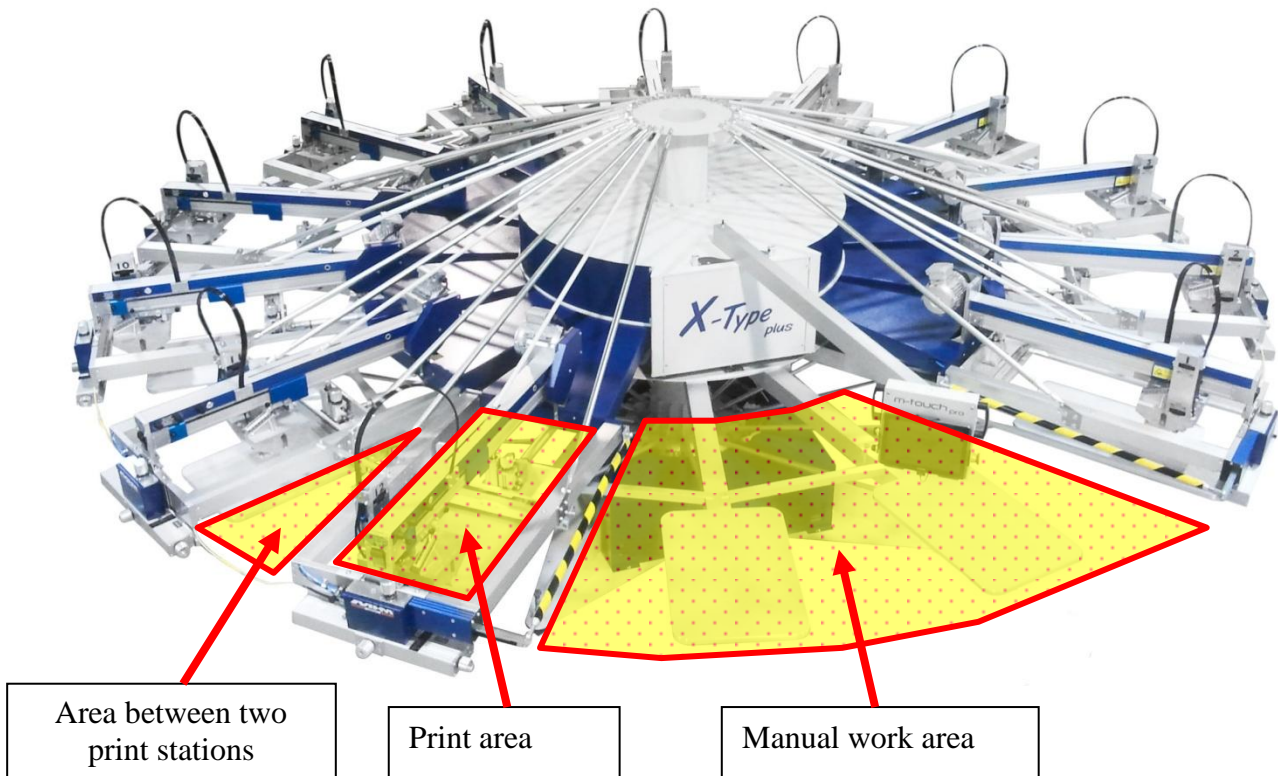

In this connection we indicate the following danger zones:

- **Manual Work Area with Locating Surface and Unloading Point**
The manual work area is located in the front of the machine and is used for applying the substrate to the pallet as well as unloading it from the latter. When applying or unloading substrates, operators must always stand in front of and not between the pallets, in order to prevent getting caught between pallet and print station or control panel in case of a rotary motion of the carrousel (index).
- **Area between Two Print Stations**
Access to the area between two print stations is barred by safety cables. This area also involves the risk of getting caught between a pallet and a print station.
- **Printing Area**
The working/printing area involves the risk of getting limbs jammed between the squeegee carriage and rigid mechanical parts. Do not reach into these zones during the printing movement.

If any work is to be carried out with or on the machine that requires entering or placing one's hands into any of the danger zones, make sure that the machine is stopped and restart is blocked by at least one of the following conditions.

1. The Control ON/OFF switch has been switched OFF.
2. The EMERGENCY STOP push button has been pressed.
3. One of the respective safety cables has been disconnected.

9. Control of the Machine

This section explains the control features of the machine from the control terminal.



This section illustrates the most important of the command screens, not all of which may be illustrated due to the very complex software. The command screens not illustrated in particular are those of a self explanatory nature.

9.1. Starting up and shutting down the Synchroprint

The following points must be observed:

- Prior to each start-up, any possible defects of the Synchroprint must be rectified by authorized staff.
- The start-up of the machine must only be carried out by qualified and trained personnel knowing and observing all safety instructions.
- It must absolutely be ensured that only authorized persons are permitted in the work area of the machine, and that starting the machine will not endanger anybody.
- The functioning of all safety facilities/devices must be checked.
- All tools and foreign parts must be removed from the machine prior to its start-up.
- The operators must be aware of the function and position of all safety devices/facilities.

9.1.1. Putting the Machine into Operation

To put the machine into operation the following switches must be at ON-Position:

- Main power switch
The Main power switch connects or disconnects the supply voltage to the machine.
- Control ON/OFF
“Control ON/OFF” is used to switch the control power supply which supplies all control components inclusive the tablet.
- Main switch tablet
Push “Main switch tablet” shortly to start the tablet. When the tablet was in idle state before, starting takes only a few seconds. When tablet was switched off, starting takes up to one minute.

After starting up the tablet a reference drive must be made. Start with button “Start Reference Drive” when displayed. Move turntable to position until the message windows becomes green. After a short time at the right position the turntable will be locked automatically.

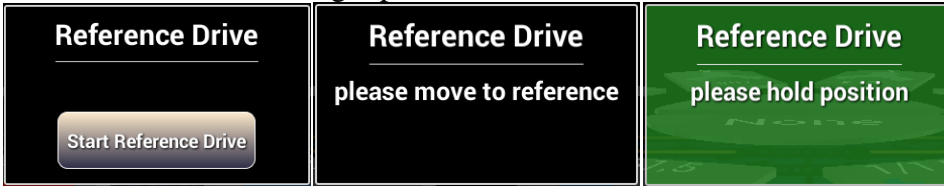

9.1.2. Switching the Machine Off after normal operation

The following order of operations must be observed when switching off the Synchroprint after normal operation:

- Clean all print stations.
- Press “Main switch tablet” shortly to put tablet into idle mode. This is necessary to prevent battery from discharging. If this is not done, the tablet must be restarted the next day. The handling is similar to modern Smartphones.
- Switch off control power supply with “Control ON/OFF”-Switch. By doing this energy can be saved.
- Switch off the Synchroprint with the main power switch. This will disconnect the main power supply completely, no energy will be consumed.

9.1.3. Stopping the Machine in the event of an Emergency



There is an **EMERGENCY STOP** push button located on the control panel. The operating staff must be aware of its location in order to stop the machine in the event of an emergency as quickly as possible.

If the operator detects any danger to personnel or the Synchroprint, he can immediately shut down the machine by pressing the **EMERGENCY STOP** push button.

On both the left and right hand side of the load/un-load stations there are two safety bars marked yellow/black, which stop the machine immediately when actuated.

Between each print station there are yellow safety cables. To enter the danger zone the cable must be disconnected and the machine will stop immediately.



When having dangerous electrical problems the main power switch must be used to disconnect the machine from the main supply voltage immediately.



These safety devices must not be used to switch off the machine under normal operation. Any EMERGENCY STOP presents an exceptional loading to the servo-motor and transmission etc. Excessive use will result in damage to the machine along with subsequent cancellation of the warranty.

9.1.4. Stopping the Machine in the event of Malfunction

If the main control system detects any electrical or mechanical malfunction, the main drive will be disabled/de-activated automatically for the safety and protection of the operating staff.

9.1.5. Long-term Shutdown

This refers to a scheduled long-term shutdown of the Synchronprint. The following steps must be carried out:

- Remove all the printing screens along with the pallets.
- Clean all print stations.
- Switch off tablet. Press “Main switch tablet” for longer than one second to start special menu. Press “Power off” when displayed.
- Switch off control power supply with “Control ON/OFF”.
- Disconnect the power supply with main power switch.
- Switch off the compressed air supply.
- Carry out a thorough cleaning of the machine.

9.1.6. Permanent Shutdown of the Machine

If the Synchronprint is to be shut down permanently or decommissioned (e.g. disposed of/scrapped), upon disassembly all individual parts must be disposed of according to their class of substance, in accordance with all respective regulations in effect at that time in the machine’s particular location/country, through a licensed waste-disposal company.

9.2. Configuration of the Control

The control of Synchronprint consists of the tablet “m-touch pro”, a central control PCB with inputs and outputs and control units at the print stations. Operation is carried out by touching the tablet or pressing the buttons at the control units of the print station.

Machine can be controlled by the following menu images:

- Adjust
- Manually
- Automatic
- Basic Setup
- Help

To change between the menu images touch the respective area at the top of the screen. The active menu image can be identified by the grey background color.

Touching the screen with two fingers and moving them up or down changes the angle of view. Moving the fingers together or apart changes the enlargement.





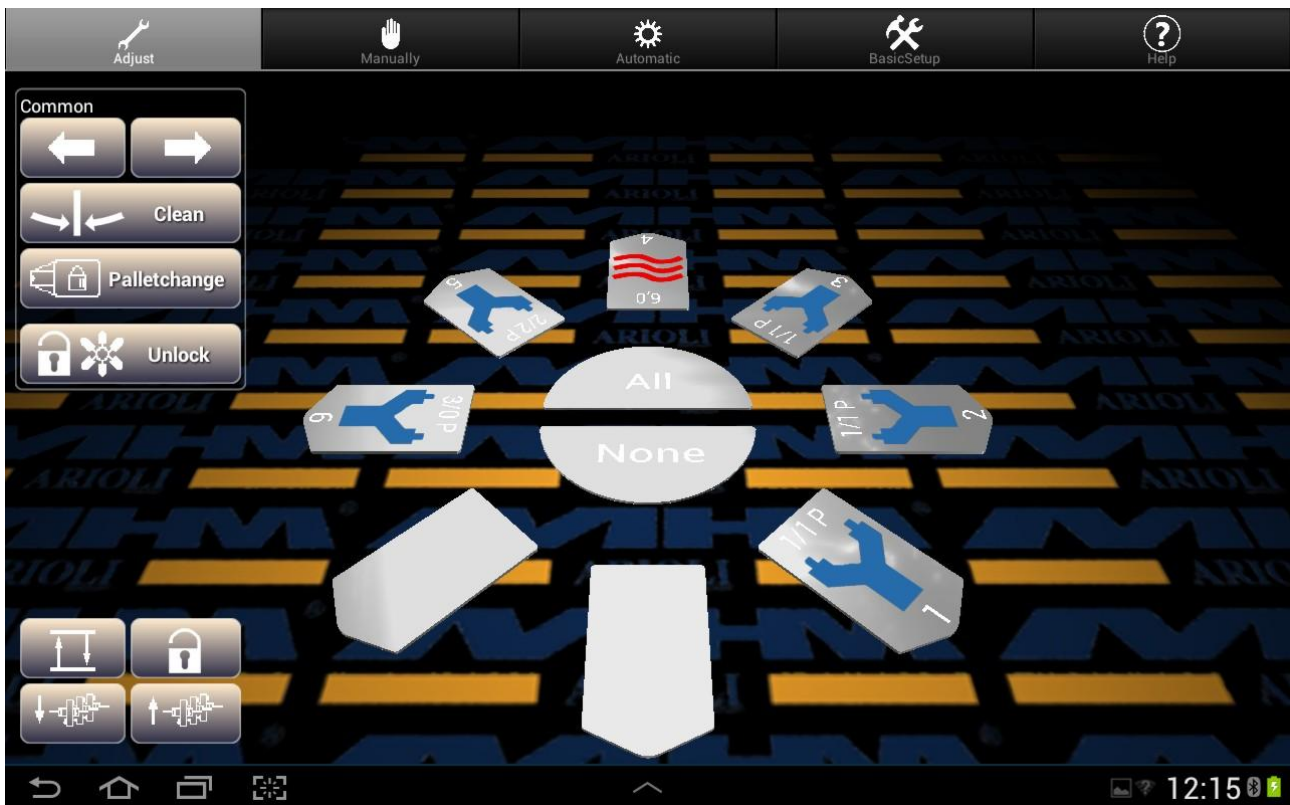



9.3. Menu Images

9.3.1. Adjust



The machine setup is displayed in the center of the machine. To change the setup, first choose the affected station by touching on it and then change its configuration. The station can be deselected by touching it again. It is possible to select more than one stations, active stations are displayed in red color. Possible settings for chosen stations are displayed on the right side of the Image. Using the buttons ALL and NONE quickly selects all stations or no station.

The following control panels are available:

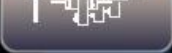
Button	Functional description
	Indexes/moves the turntable directly to the next print station on the left.
	Indexes/moves the turntable directly to the next print station on the right.
 Clean	Moves the turntable into the clean/half index position.
 Palletchange	Allows the operator to lock or release the pallets.
 Unlock	Unlocks the turntable and allows free manual turning.
	Raises or lowers the screens to off-contact position.
	Lock and Unlock the screen pneumatically.
	Moves all squeegees to the outer position.
	Moves all squeegees to the inner position.

If a print station is selected the following control panels are displayed.



“On” activates a station, appending parameters are displayed.
 “Off” deactivates a station.

Determines the number of print strokes at a print cycle.

Determines the number of flood strokes at a print cycle.

Select this when plastisol ink is used. Print cycle starts with a flood stroke followed by the print stroke.

Select this when waterbased ink is used. Print cycle starts with a print stroke followed by the flood stroke to prevent screen from drying up.

Start a print cycle with the programmed number of print and flood strokes.

Switches to the following control panel.

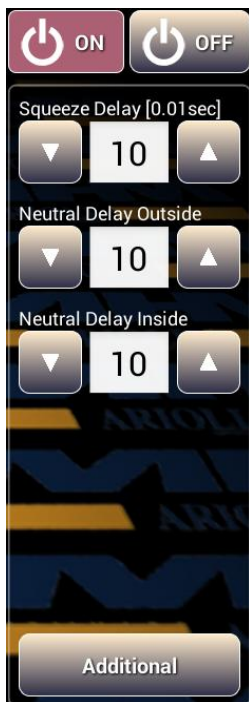

“On” activates a station, appending parameters are displayed.
 “Off” deactivates a station.

Start delay for squeegee movement. Input in hundredth of a second.

Shifting time for squeegee center position outside. Input in hundredth of a second.

Shifting time for squeegee center position inside. Input in hundredth of a second.

Switches to previous control panel.

When a dryer is detected by the machine the following control panels are displayed:

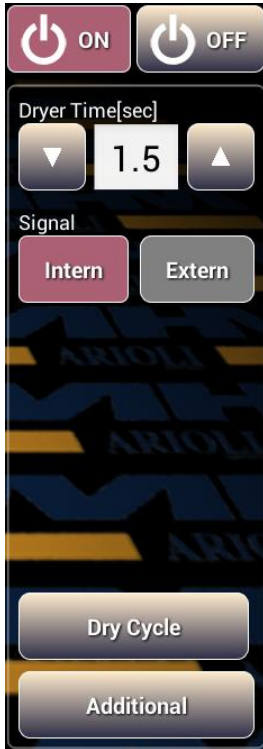

“On” activates a station, appending parameters are displayed.
 “Off” deactivates a station.

Determines the drying time. When time is set to 0, drying mode switches from internal to external automatically.

“Intern”: Drying time is controlled by the machine. Enter time in the field above.

“Extern”: Drying time is controlled by the dryer. Machine waits for a complete signal send by the dryer.

Start a drying cycle with the programmed parameters.

Switches to the following control panel.

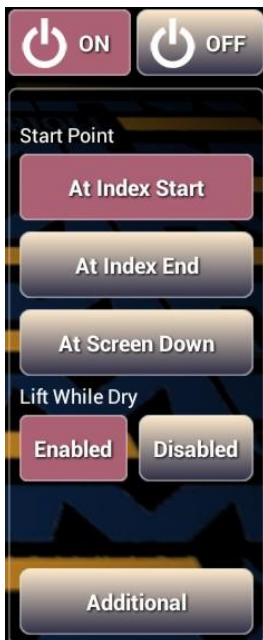

“On” activates a station, appending parameters are displayed.
 “Off” deactivates a station.

Drying starts at the beginning of an index.

Drying starts at the end of an index.

Drying starts after the machine has lowered to off-contact position.

„Enabled“: Lifting screen during drying is allowed.

„Disabled“: No screen lift during drying.



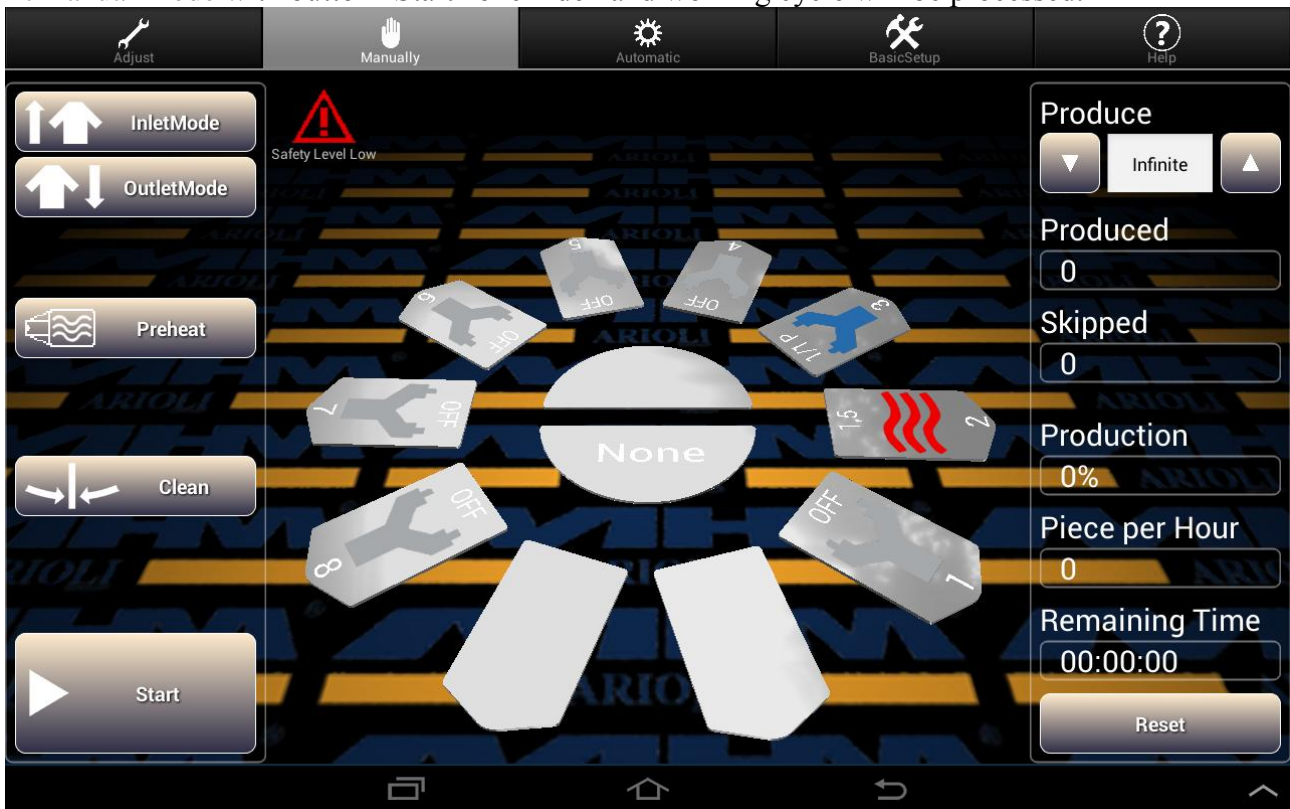

Switches to previous control panel.

9.3.2. Manually

At manual-mode with button “Start” one index and working cycle will be processed.



The following buttons are displayed:

Button	Functional description
 InletMode	Is used for the sequential start of a new print job/run. It activates each selected print station/flash cure unit in sequence when commencing a production run. After the first complete printing cycle with all enabled print stations/flash cure units, the startup mode will be turned off automatically.
 OutletMode	Is used to switch off the print stations one by one when print job is finished. A separate command screen will be displayed with options Continue, Outlet and don't flood at waterbased inc.
 Preheat	Warming up the pallets to working temperature. For this only active drying stations are used. Warming up is necessary to get the same print results from the beginning.
 Clean	Moves the turntable into the clean/half index position.
 Start	Start a print cycle including index. An optional foot switch provides the same function, only the first start command must always be given at the control panel.

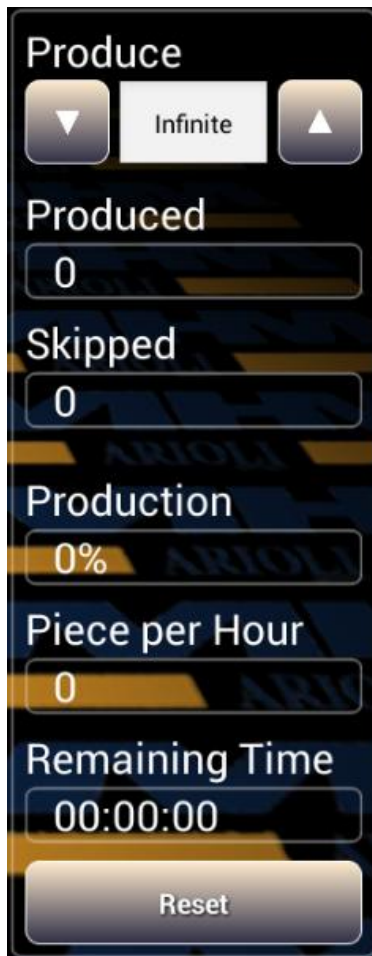

Determines the desired quantity of the production job. The value can be changed with the up and down arrows or by direct number input after touching the field

Displays the number of items which have been produced since the last “RESET”.

Displays the amount of skipped tables since the last reset.

Displays status of the actual job in percentage.

Displays the hourly output of the machine at actual speed.

Estimated remaining time for actual print job at actual speed.





Clear the counters “Produced” and “Skipped”.

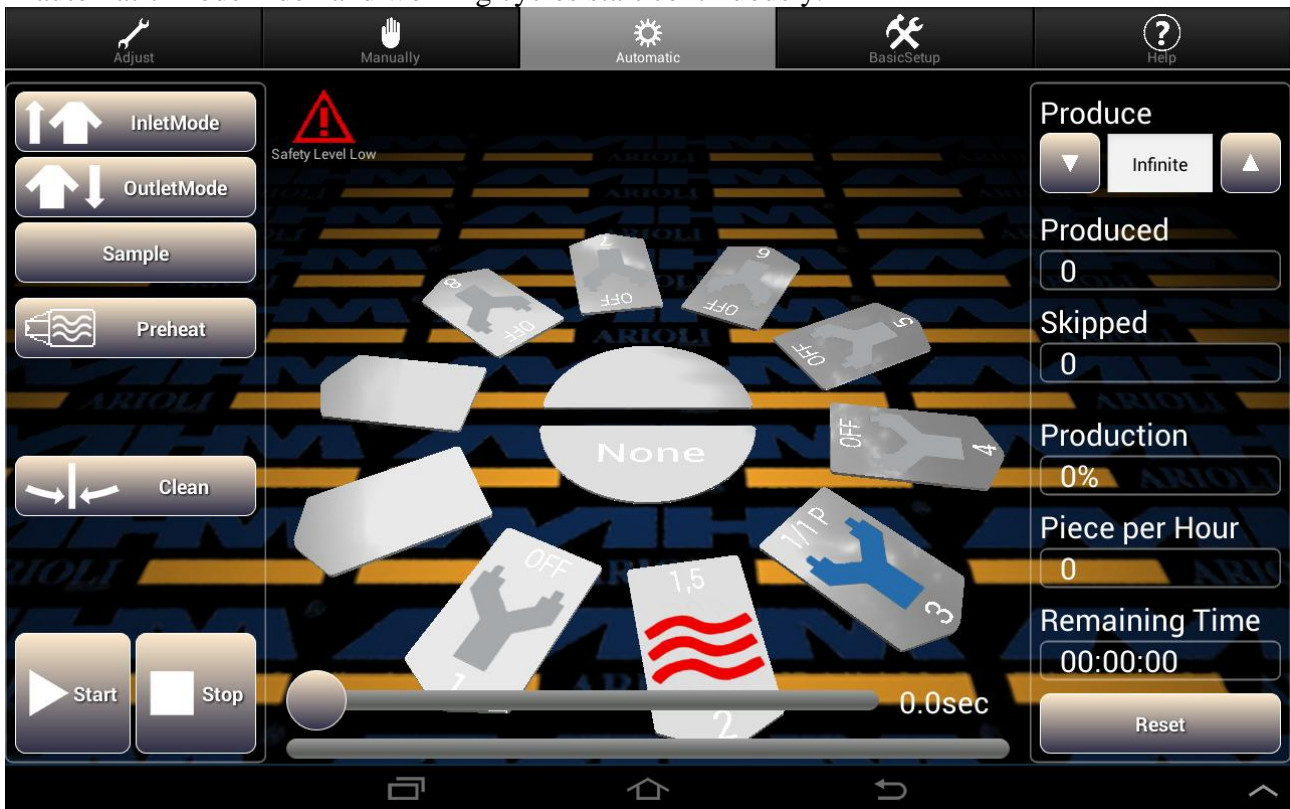

9.3.3. Automatic

In automatic-mode index and working cycles start continuously.



The following buttons are displayed:

Button	Functional description
	Is used for the sequential start of a new print job/run. It activates each selected print station/flash cure unit in sequence when commencing a production run. After the first complete printing cycle with all enabled print stations/flash cure units, the startup mode will be turned off automatically.
	Is used to switch off the print stations one by one when print job is finished. A separate command screen will be displayed with options Continue, Outlet and don't flood at waterbased inc.
	Starts a sample print. The desired amount can be increased by pressing the button "Sample" more often. The actual adjusted amount is displayed at "Produce". The sample will automatically perform the required inlet and outlet mode, the manual adjustment is not necessary.
	Warming up the pallets to working temperature. For this only active drying stations are used. Warming up is necessary to get the same print results from the beginning.

Button	Functional description
	Moves the turntable into the clean/half index position.
	Starts the automatic production. When a working cycle is finished the next index move starts automatically. An optional foot switch can be used to pause before next index move.
	Interrupts the actual print job after actual working cycle.

The slider delays the next index move. This can be used to give operators more time to do their work. Shift the round button to the left or right to change the desired time. The actual adjusted delay time is displayed on the right.

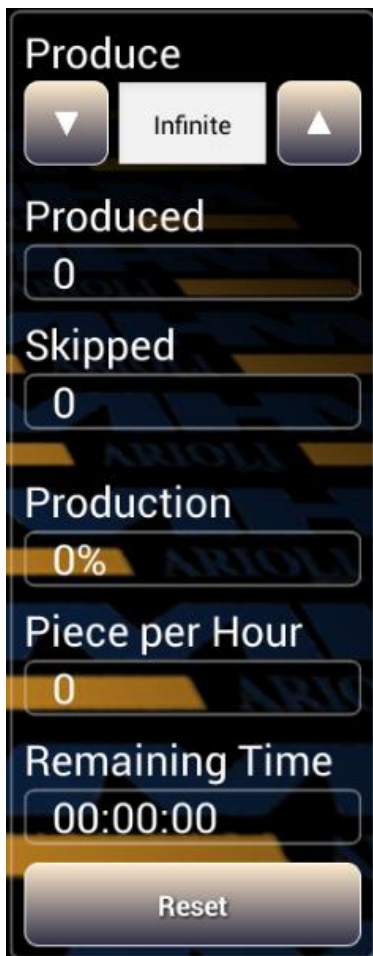

Determines the desired quantity of the production job. The value can be changed with the up and down arrows or by direct number input after touching the field

Displays the number of items which have been produced since the last “RESET”.

Displays the amount of skipped tables since the last reset.

Displays status of the actual job in percentage.

Displays the hourly output of the machine at actual speed.

Estimated remaining time for actual print job at actual speed.





Clear the counters “Produced” and “Skipped”.

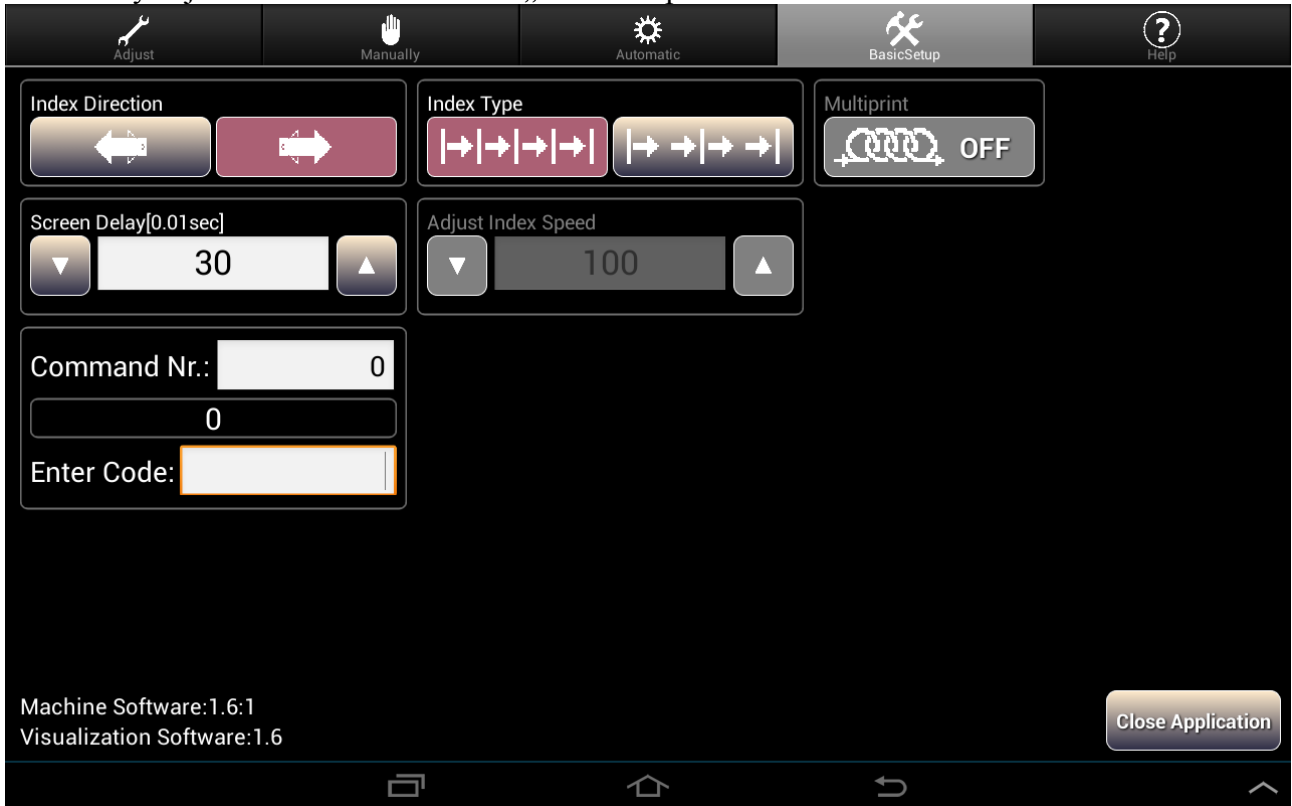

9.3.4. BasicSetup

Elementary adjustment must be made in „BasicSetup“.

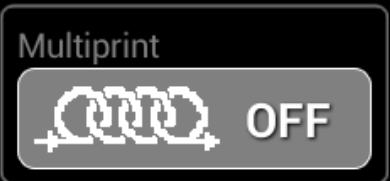
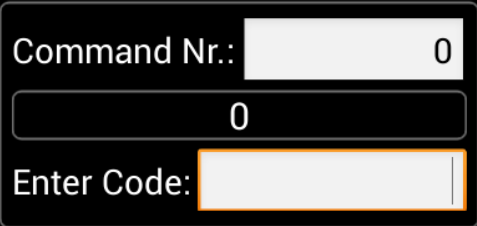

The following buttons are displayed:

Button	Functional description
	Defines the direction of rotation.
	Switches between single and double index. At double index two index moves are made between one working cycle.
	Delay time screen lift. Required time to raise or lower screen. Input in hundredth of a second.
	Optional parameter for index speed. Input in percentage of maximum index speed.

Button	Functional description
	Activates optional “Multiprint”-function. A separate manual is available.
	„Service“-menu.
	Closes the controlling software and display start screen of the tablet.

9.3.5. Help

“Help” supports you at troubleshooting and controlling the machine.

9.4. Error messages

If an error is recognized by the control unit a message will be displayed on the tablet. Beside an error message you get an error description. After the error reason is eliminated the message must be cleared by pressing the „Confirm-Button“.







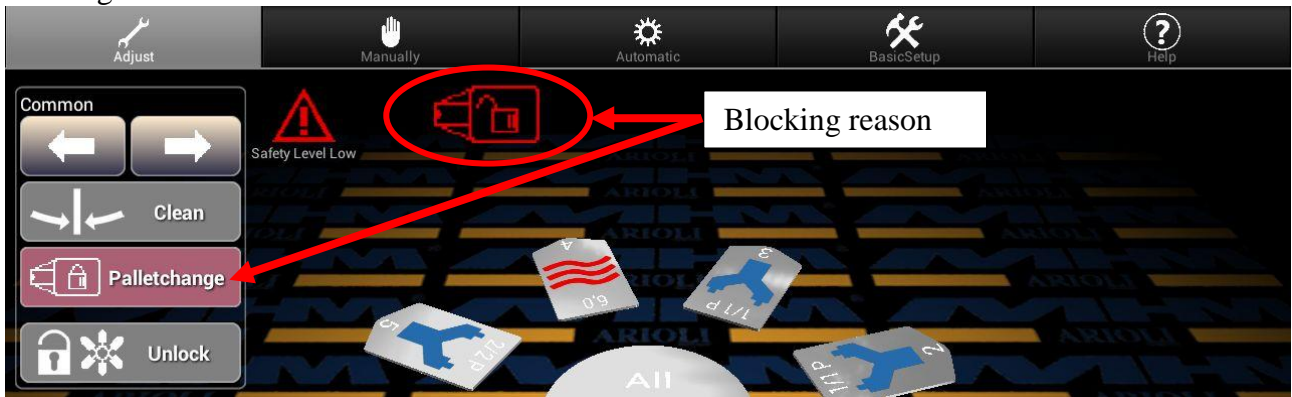

9.5. Blocked operation

In several working positions operation will be blocked automatically. The reason for blocking will be displayed by a symbol or pressed buttons on the tablet. To operate the machine again the blocking reason must be eliminated.



The following reasons block machine operation:

Label	Symbol or button	Description / trouble-shooting
Tablet not connected.		The tablet is not connected to machine control.
Palletchange	 + 	Palletchange function is active.
Clean		Turntable is on clean position.
Unlock table	 + 	Turntable is unlocked and turns free. Reference drive is necessary.
Unlock screens		Screens are unlocked.

9.6. Trouble shooting



Before trying to locate any fault, it must be made sure that the machine may not move unintentionally. Before entering the danger zones, one of the machine's safety facilities/devices must be actuated; in case of required work on current-carrying parts, the machine must be cut off from the supply voltage (using the main power switch).

9.6.1. Error Messages control system

The following error messages can be displayed on the tablet:

Error message	Error description	Error reasons / actions
Emergency Switch	Emergency stop	Emergency stop button was pressed. Safety bar was pressed. Safety cable was opened. "Control ON/OFF" is on off position.
Low Pressure	Failure signal from main air pressure sensor.	Air supply is not connected. Wrong pressure adjusted. Air supply pressure is too low.
FU Alert	Error from main frequency converter	Frequency converter is in error state.
"Check Station" + number of station	Timeout at print- or dryer station	Timeout ready signal dryer. Timeout squeegee carriage didn't start. Timeout squeegee carriage didn't reach end position.
Inverter Communication Error	Error CAN-communication with main frequency converter.	Only at option "Adjustable Indexspeed" available. Communication with main frequency converter is disturbed.
Index Timeout + error reason	Movement of index disturbed	Fix Pin: Error fixing pin Position Fail: Index position not reached FU Ready Signal: Main frequency converter ready signal is missing. Pallet Unlocked: Signal pallets unlocked. Drive Pin: Error transport pin. Pos Sensor: Index position not reached
"Diverse system errors" + READJUST + error code + please call MHM-Service	System error	Please contact MHM service department for further information.

After the error reason is eliminated the message must be cleared by pressing the „Confirm-Button“.

9.6.2. Basic errors (without error message)

The following error reasons are not recognized by the control system and no error message is displayed:

Error description	Possible reasons	Trouble-shooting
It's not possible to start the tablet m-touch pro	Main power switch is switched off and battery is empty.	Switch on main power switch!
	“Control ON/OFF” is switched off and battery is empty.	Switch on “Control ON/OFF”!
	Tablet isn't connected and battery is empty.	Connect tablet with machine control!
	Power supply of machine is missing and battery is empty.	Reestablish power supply!
Safety level can't be adjusted.	Safety key is not connected to unit control.	Check wiring from unit control to safety key!
	Wrong wiring of safety key at control panel housing.	Put control panel out of housing and check wiring of safety key!
Squeegee does not toggle at squeegee carriage movement.	Squeegee pressure too low.	Adjust pressure control at print station!
	No air pressure at print station.	Is manual screen lift working? YES: Pressure existent. No: Upper pressure stop cock active or tube snapped off.
	Valve not actuated.	Check wiring of squeegee valve!
Screen lift does not work.	No air pressure at screen lift unit.	Tube snapped off.
	Valve not actuated.	Check wiring of screen lift valve!
Unlock screens does not work.	Wrong low pressure adjustment.	Check adjustment of pressure regulator.
	Valve not actuated.	Check wiring lock/unlock valve!

10. Maintenance of the Synchroprint



Before doing maintenance work the machine must be cut off from the supply voltage using the main power switch).

The Synchroprint has been designed to operate ‘maintenance-free’ as far as possible. Only a few important service measures are necessary by the operator.

Task	Frequency	Comment/Action
Daily cleaning	Daily	Remove all residues from the Synchroprint remaining from production materials such as inks and adhesives etc. Clean, tidy and sweep the printshop area.
Check inspection glass on water separator/trap	Daily	The inspection glass of the water separator/trap must be checked for condensed water. The level must not exceed the red mark; otherwise the automatic relief aperture may become clogged or defective.
Weekly cleaning	Weekly	Wash off all anodized parts of the Synchroprint with an appropriate cleaner. Clean all inspection glasses and displays. Clean or replace the protective foil on the touch screen.
Cleaning the Control Panel	Weekly	The control terminal must only be cleaned with a dry cloth or appropriate monitor-cleaning cloth. If any aggressive cleaners or solvents are applied, the surface of the keypad will be damaged or destroyed, resulting in cancellation of the warranty.
Wipe clean the sealing band on the underside of all the linear profiles	Weekly	The sealing band on the underside of the linear profiles must be wiped clean thoroughly and lubricated with an oil-soaked cloth.

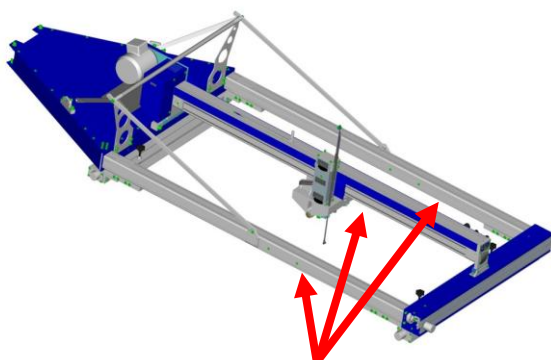

Sealing band on the underside of the linear profiles

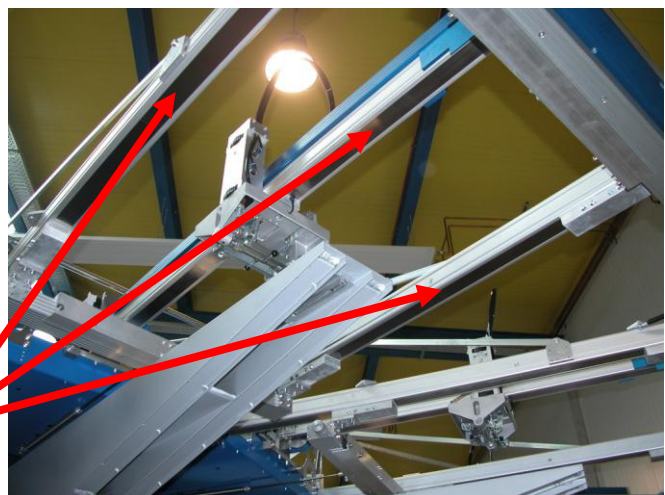

Task	Frequency	Comment/Action
Lubrication	Every 6 months	<p>The fixing pin, the transport pin and the torque support must be lubricated every 6 months through the lubrication nipples. MHM recommends “Berner Heavy-Duty Multi-Purpose Grease” or a comparable grease with the following technical specifications:</p> <ul style="list-style-type: none"> ▪ Water-repellent, supple lithium grease ▪ Dropping point at approx. +195° C ▪ Effective lubrication range from -20° C to +120° C
Clean automatic relief aperture	Monthly	The entire water separator/trap is attached to the pressure regulator with a bayonet lock. Take off the water separator/trap and clean the automatic relief aperture.

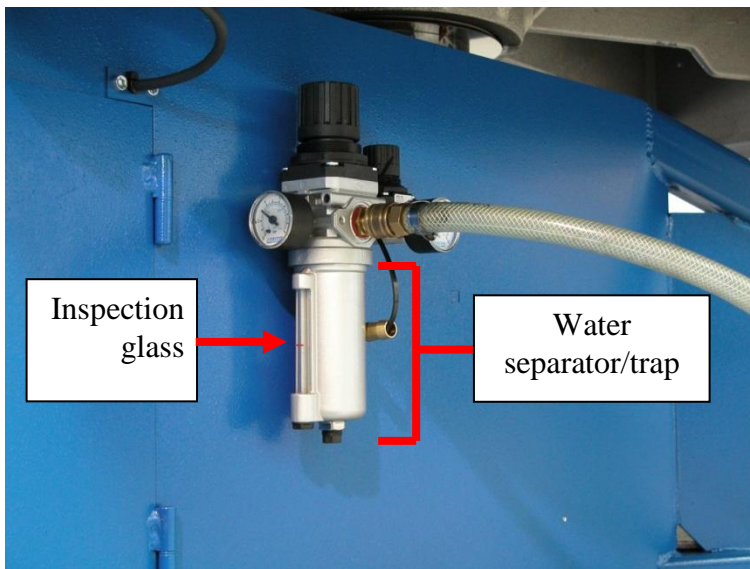

Clogged valve silencers cause lowered speed of pneumatic functions. In that case the silencers must be changed.

11. Terms of the Guarantee

The terms of the guarantee are detailed in the General Terms and Conditions of Machines Highest Mechatronic GmbH.

12. Limitation of liability

Warranty and liability claims for personal injury and material damage are **excluded** if they can be attributed to or are a result of one or several of the following:

- Improper use of the Synchronprint.
- Incorrect assembly, operation or maintenance of the Synchronprint by the operator.
- Operation of the machine with defective safety devices and/or safety devices which are missing / removed or not in correct working order.
- Failure to comply with the safety instructions in this document with regard to transportation, assembly, start-up, installation, operation, control and maintenance of the Synchronprint.
- Failure to comply with the Operating Instructions.
- Unauthorized modifications to the Synchronprint (e.g. disassembly of original MHM components and/or use of any non-original MHM components)
- Unauthorized modifications to any part of the drive or control systems (e.g. change of control components or frequency converters).
- Lack of monitoring and maintenance of machine parts/components subject to wear and tear.
- Repair measures, maintenance or service work carried out by unauthorized persons.
- Use of lubricants other than those recommended by MHM.
- Operation of the machine under technical conditions other than those specified by MHM (e.g. excessive power supply voltage and/or excessive air pressure).
- Damage by any foreign object and/or force majeure.
- Omission of specified maintenance, service measures and procedures.
- Operation of the Synchronprint by untrained personnel.

13. Support, Customer Service and Hotline

In case of any problems or additional questions please turn to your appropriate service partner.