

HIX PREMIER PRINTERS

Manual Screen Printer

CONVERTIBLE/RALLY/CRUISE/GT SERIES

OWNER'S MANUAL



6 Color / 4 Station
CRUISE model shown



CORPORATION

For Customer Service, Call **1-800-835-0606**

or Visit www.hixcorp.com

CONTENTS

| | |
|----------------------------------|-------|
| Printer/ Assembly | 2-4 |
| Set Printhead | 5 |
| Screen Installation & Adjustment | 6 |
| PrePress and Registering | 7-11 |
| Gas Spring Replacement | 12-13 |
| HIX Manual Printers | 14-15 |
| Warranty | 16 |

BEFORE warranty repair you MUST get Prior Authorization:

PRINTER ASSEMBLY

TOOLS REQUIRED:

- (2) 9/16" Wrench
- (2) 1/2" Wrench
- (1) 7/8" Socket and Ratchet
- (1) Phillips Screwdriver

Assembly (if press is assembled/ partially assembled go to next step)

ARM ASSEMBLY

1. Slide each arm under the flange nut on lower print wheel, and then tighten from the bottom.
2. Insert the additional (2) 1/2" bolts (Fig 1) to print arm flanges and tighten.

BASE ASSEMBLY

Empty the contents of **ALL** cartons on the floor.

NOTE: This will require two people.

1. Place leg assembly on floor, leveling pads down.
2. Align base with (4) holes on leg assembly. (2 people required)
3. Tighten the (4) 3/8" bolts down to leg assembly with 9/16" wrench.
4. To level printer adjust leveling pads and tighten jam nuts.



Fig 1

PRINT HEAD ASSEMBLY

1. Remove the nut, bearing cap cardboard tube and plastic shrinkwrap from spindle (Fig 2).
2. Remove the top bearing from spindle and set on a clean cloth.
3. Place print head wheel assembly over spindle.

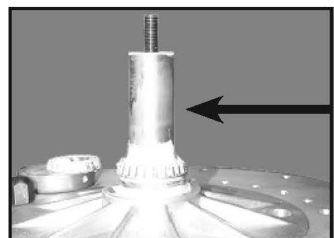

Fig 2

PRINTER ASSEMBLY

NOTE: Make sure the bearing is seated evenly in the bearing race on the bottom of the printwheel assembly such that wheel assembly **turns freely**. 2 people required (Fig 3).



Fig 3

4. Place the tapered end of the bearing into the top race of the printwheel assembly and hand tighten the cap on screw until snug. The cap on screw can then be tightened an additional $\frac{1}{4}$ turn by inserting a rod into the hole in the top of the bearing cap. (Fig 4)

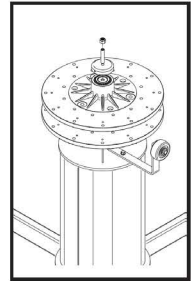

Fig 4

SHIRTBOARD POSITION

5. Holding the bearing cap in place, tighten the nut firmly on the top of the spindle assembly.

NOTE: Spin and gently rock both upper and lower printwheels to assure bearings are seated properly (Fig 5).



Fig 5

Attach shirtboards on the print arms, flat side in, push the shirtboard to the back until they rest just under the print head and tighten them using the knobs located on the side **FIRST**. Tighten the bottom knob second on the shirtboard clamps (Fig 6).



Fig 6

PRINTER ASSEMBLY

REGISTRATION GUIDE ALIGNMENT

1. Lower **all** print heads (Fig. 7). Tighten the (2) bolts (Fig. 8) that secure the registration guide bracket to the arm.

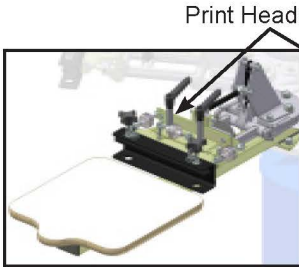

Fig. 7

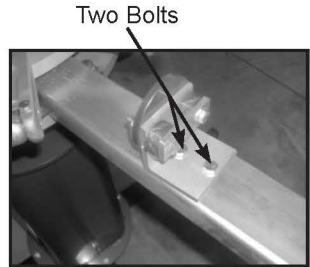
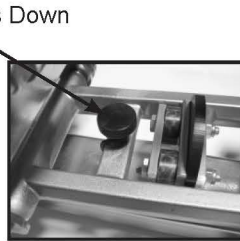

Fig. 8

NOTE: This procedure must be done to ensure all print heads will register for printing.

BRAKE WHEEL ADJUSTMENT

1. The brake wheel is mounted so as to allow the wheel to be raised or lowered to provide the braking action desired.
2. Loosen the retaining bolt and align brake wheel under a print arm.
3. Insert a Phillips screwdriver into the hole on the brake wheel shaft. (Fig. 9)
4. Raise or lower the brake wheel by moving the screwdriver to the desired brake resistance (Fig. 9).



Fig. 9

5. Tighten the retaining bolt and check the braking action.
6. Re-adjust if needed.

SET PRINTHEAD



NOTICE: Failing to properly set up printhead level will not allow print to be registered.

YOUR HIX PRESS MUST BE REGISTERED ON CONTACT!
(Meaning the exposed screen is touching the shirtboard.)

1. **Front to rear adjustment.** Insert Screen into screen clamp (see page 6) and adjust the screen tilt adjustment (see page 9).

Adjust so that the screen is parallel with the shirt board front to back, and make sure your screen sits totally flat on the shirtboard. Or the screen **will** slip when you tighten the ratchet handles. (See handles on page 7 Fig. 13)

2. **Left to right/ Parallel adjustment.** Be sure the back screen clamp (or cross tube holding side clamps) is level and parallel in relationship to the shirtboard. (Left to right on the shirtboard) There are two bolts that secure the back clamp (or crosstube) to the lower registration plate. Slightly loosen nuts holding these bolts. The left side of the back clamp (or crosstube) is oversized which allows you to move the clamp (or crosstube) to align the screen parallel to the shirt board. Adjust to parallel and tighten.

NOTE: If not level after tightening repeat steps 1 and 2 above.

WARNING: Failing to level this section of the printer will cause an un-even contact from the left to the right or front to rear. This may will cause the screen to “slip” or move when you tighten the registration ratchet handles.



Back clamp



Cross tube that holds side clamps

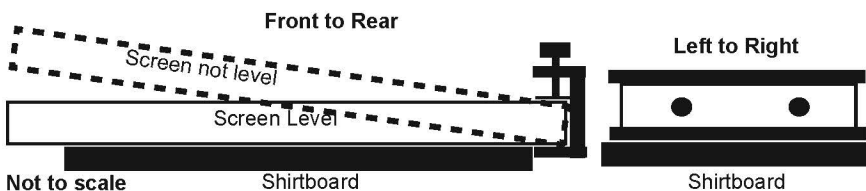

Not to scale

Shirtboard

Shirtboard

SCREEN INSTALL. & ADJUST.

FOR BACK CLAMPS: (FIG. 10)

1. Loosen both black knobs on the back clamp and center the screen in the clamp making sure the screen is all the way inside the clamp.
2. Tighten the black knobs so that they securely grip the screen.

FOR SIDE CLAMPS: (FIG. 11 AND 12)

(If the side clamp is not attached see Fig 12)

1. Loosen the two black adjustment knobs on each side clamp wide enough to accept the screen.
2. Loosen the angled back knob on the back of each side clamp and move clamps far enough apart on the cross tube so that the screen will fit into the clamps.
3. Insert the screen into the side clamps and press clamps inward so that they are against the sides of the screen frame and centered over the shirtboard. Center on the crosstube.
4. Gently tighten the angled knobs on the cross tube.

NOTE: Do not overtighten.

5. Tighten the two black knobs on each side clamp to securely grip the screen.

Back Clamp Fig. 10

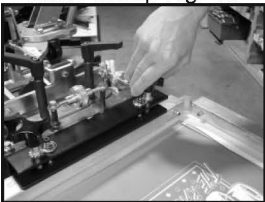

Side Clamp Fig. 11

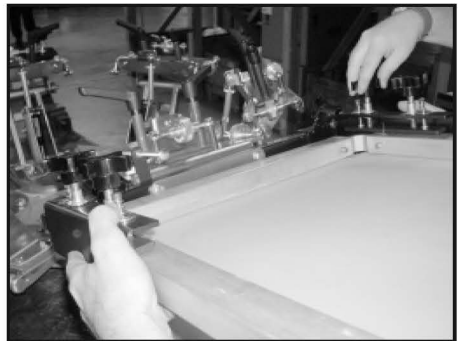

Slide this side over cross tube.



Fig. 12

NOTE: The bolt securing the left hand side of the cross tube is in an oversized hole allowing for adjustment if a screen is slightly warped or twisted. Likewise, printers configured with the back clamp feature a similar slotted hole which exists to allow for leveling of the screen.

Remember if you modify this adjustment for a warped screen, to reset printhead for flat screen (see page 5)

Loosen the nuts on the cross tube or the back clamp. Adjust up or down so that the screen is parallel (right to left) to the shirt board.

PREPRESS & REGISTRATION

NOTICE: Before printing follow these steps below.

1. The first step involves setting all micro register heads to a neutral position. This can be done by loosening the ratchet handles approximately a 1/4 turn (Fig. 13) and then turning the three registration knobs (Fig. 14) until the arrow tab points (Fig. 15) to the center of the inscribed cross hairs.

Perform this adjustment on every print head that takes a screen.

ratchet handles

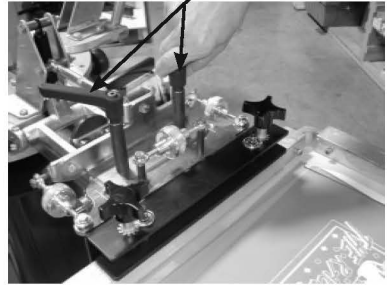

Fig. 13

registration knobs

Fig. 14

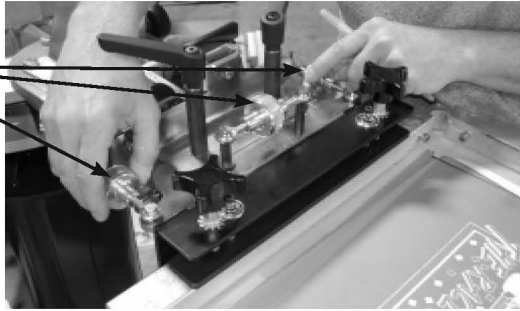
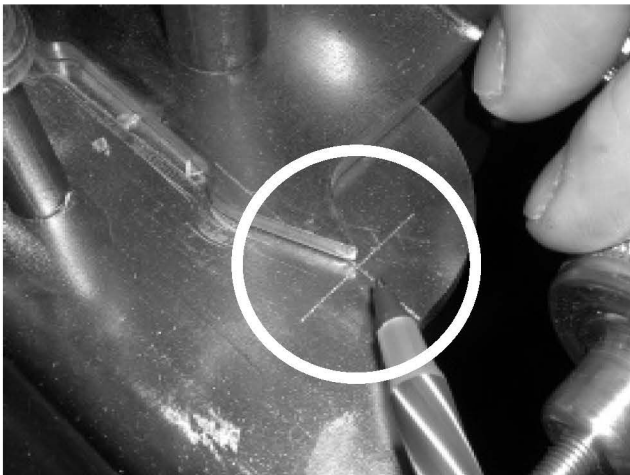

Fig. 15



PREPRESS & REGISTRATION

- Center, level, and tape your art/film positive (normally the black or trap) on **one** shirt board using a T-Square and a ruler. Roughly center or position to desired location. Make sure all printable images lie within the boundary of the shirtboard. (Fig. 16) Then register your screens to the film positive (see page 9). (**film positive**- Any artwork on a clear film that can be used to expose a screen.)



Fig. 16

- Optionally, if you do not have a positive or vellum; you can spray tack adhesive on the shirt board, then load a shirt or **pellon** onto the board. Then “**print**” the black/darkest color or **keyline positive** directly onto the shirt or pellon. Cure, then register your screens to this print (see page 9). (**keyline positive**- the outline that traps all other color separation positives. **pellon**- test print material, so to not ruin usable material.)

NOTE: Slight adjustments to the shirtboard to improve alignment may be necessary.

- To adjust the shirtboard:** (Fig. 17) Loosen the shirt board and position so that it lines up with the screen frame when it is lowered into the horizontal position.

REMEMBER to tighten the side knob first and then the bottom/larger knob.

- Lower the screen onto the shirt board with the taped artwork.
- Loosen the screen clamps on back clamp models or angled back knob on side clamp presses and center the screens side to side if needed.

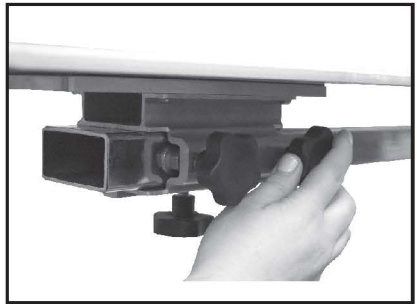

Fig. 17

Note: Keep in mind you still want the screen to **fit tight** against the back of the screen clamps to improve support. (Fig. 18)

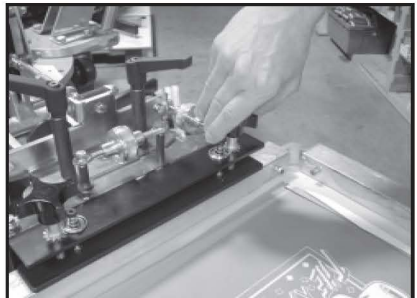
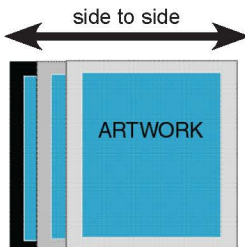

Fig. 18

PREPRESS & REGISTRATION

7. Lower your screen all the way down to the shirt board. You may have to use the **off contact adjustor** (Fig. 19) and your **screen leveler** (Fig. 20) to achieve front to rear "contact" with the shirt board. Now slightly loosen the ratchet handles. You should be able to notice the movement of the screen after adjusting the three adjustment nuts. (Fig. 14)

off contact adjustor

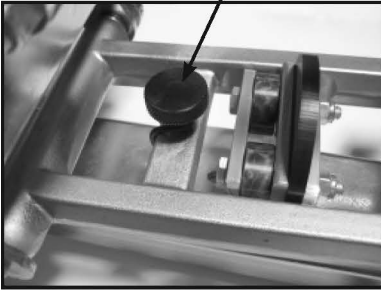

Fig. 19

screen leveler

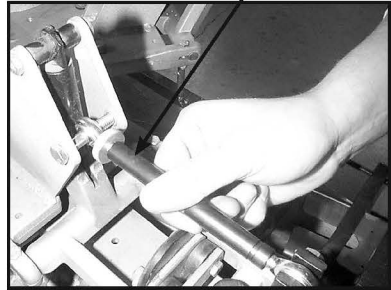

Fig. 20



Shirtboard



Shirtboard

If not parallel left to right see page 5, step #2.

8. Looking through the screen (Fig. 21) use the adjustment knobs. (Fig. 22-23)

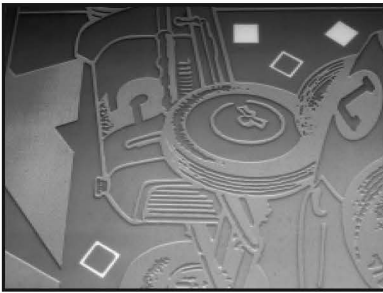

Fig. 21



Fig. 22

Once you have achieved perfect lineup with the screen and art, hold the screen down with your hand and then working back and forth, gently snug up the ratchet handles (Fig. 23) until the screen is firmly locked in place. Recheck your registration then use the off contact and the screen leveling adjustment to raise the screen approximately 1/16" off the shirtboard surface.

NOTE: If your ratchet handles are too tight you may cause damage to the adjustment nuts by forcing them. (Fig. 23)

PREPRESS & REGISTRATION

If your clamps are too loose when you begin the adjustments (Fig. 23) your screen may jump out of registration during final clamping. (See page 5)

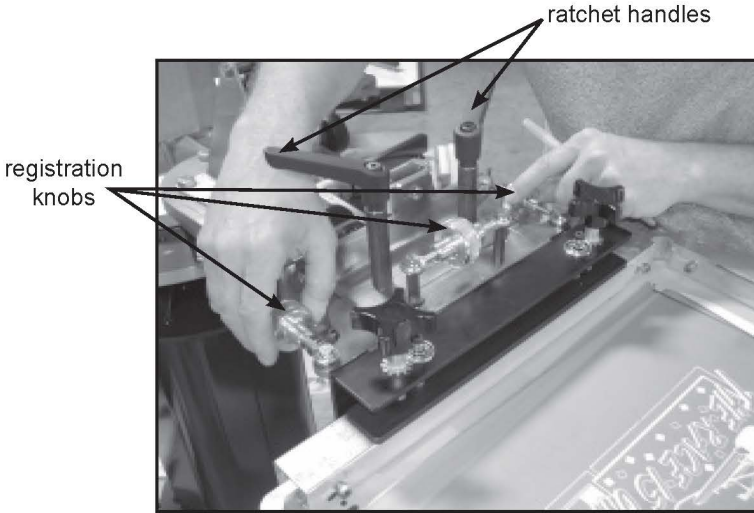

Fig. 23

9. Before proceeding to the next print head alignment, measure the distance between the end of the shirt board clamp and the registration guide on the print arm. This distance should be the same for all the other shirt boards in the setup process. (Fig. 24) Adjust if necessary see shirtboard position pg. 3

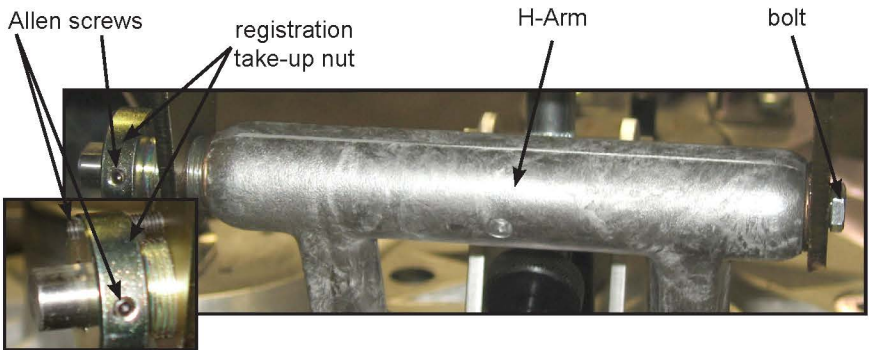

Fig. 24

NOTE: Over time the bushings (Fig. 25) between the micro-registration and the H-Arm could become worn and create play in the print head. This play can cause prints to fall out of registration. An adjustment to the registration take-up nut (Fig. 26) on the micro-registration will need to be made.



PREPRESS & REGISTRATION



1. Loosen the two Allen screws on the registration take-up nut.
2. Loosen the 1/4-20x0.750 bolt on the opposite side of main pivot pin as the registration take-up nut.
3. Turn the registration take-up nut clockwise to tighten the space and remove any play. **BE CAREFUL NOT TO OVER TIGHTEN.**
4. Tighten the two Allen screws and bolt from steps 1 and 2.

GAS SPRING REPLACEMENT

1. Remove shirtboard and install the jacket hold down board onto the arm. Place the off-contact compensation cap over bolt head (Fig. 33).

NOTE: This cap compensates for the height increase of the jacket board over a standard board.

2. Adjust the rubber grip blades so that they are parallel with the edge of the board. Gap adjustment will vary depending on the jacket and liner thickness. (Fig. 34)

3. Center jacket over platen (Fig. 35) with latch protruding.

NOTE: On small or youth size jackets, it may be necessary to unzip the

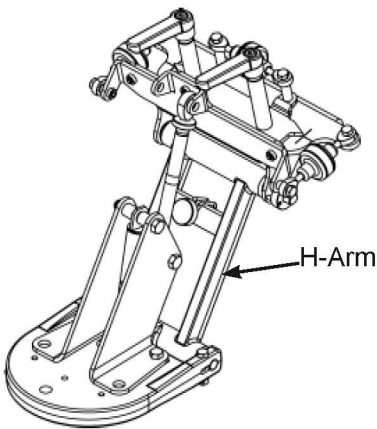

jacket front first.

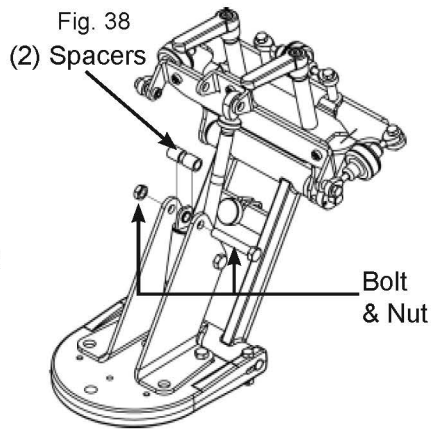

4. Lower the holddown into position (Fig. 36) and lock the toggle latch. Check the jacket position to ensure it is centered properly before printing. Reposition grip (step 2) as necessary.

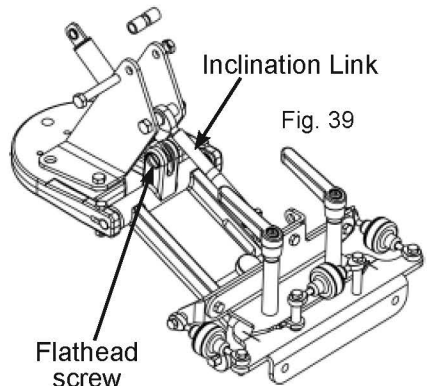

5. Lock the toggle latch so

GAS SPRING REPLACEMENT

will not tend to creep up (Fig. 37).

NOTE: It is wise to “pre-flash” each jacket before the first print is made to prevent shrinking of the jacket, which can cause registration problems when doing multi-color prints.

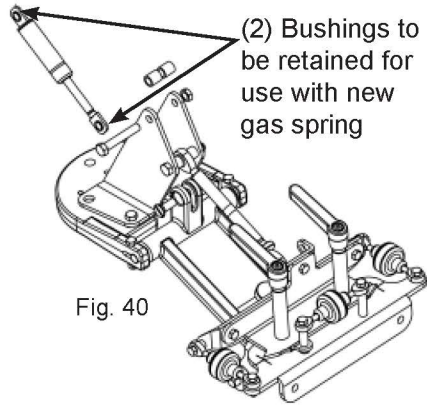
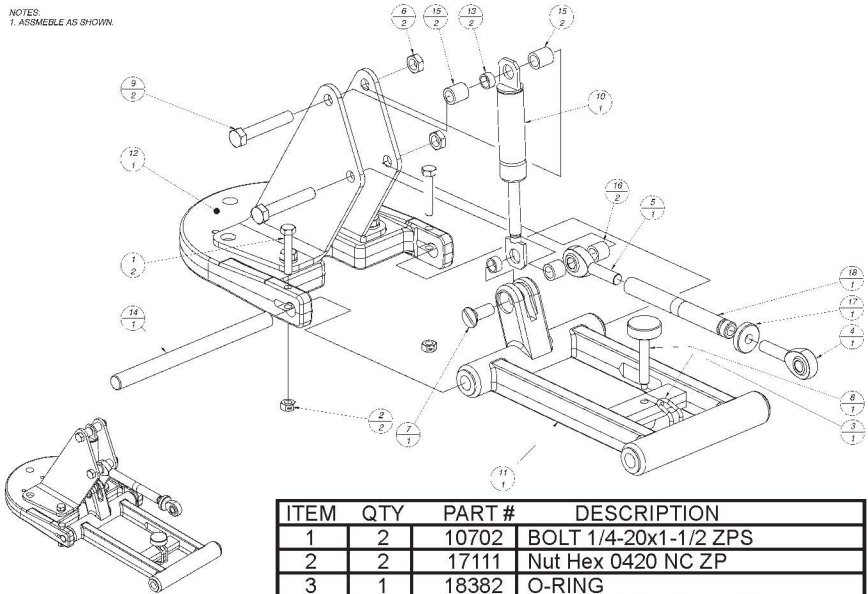

Fig. 40

NOTES:
1. ASSEMBLE AS SHOWN.



| ITEM | QTY | PART # | DESCRIPTION |
|------|-----|---------|--------------------------|
| 1 | 2 | 10702 | BOLT 1/4-20x1-1/2 ZPS |
| 2 | 2 | 17111 | Nut Hex 0420 NC ZP |
| 3 | 1 | 18382 | O-RING |
| 4 | 1 | 29991 | ROD END 3/8x3/8-24 RH |
| 5 | 1 | 30007 | ROD END 3/8x3/8-24 LH |
| 6 | 2 | 47753 | NUT HEX JAM 3/8-16 NC ZP |
| 7 | 1 | 69302 | SCREW MCH 3/8-16x1 FHSL |
| 8 | 1 | 86017 | KNOB, 5/16-18 CLAMPING |
| 9 | 2 | 86850 | BOLT 3/8-16 x 2-1/4 |
| 10 | 1 | 89326 | SPRING, 150# GAS |
| 11 | 1 | 1010600 | ASSY, H-ARM |
| 12 | 1 | 1010610 | ASSY, PRINT HEAD BRACKET |
| 13 | 2 | 1011032 | BUSHING, GAS SPRING |
| 14 | 1 | 1011033 | SHAFT, H-ARM PIVOT |
| 15 | 2 | 1011080 | SPACER, GAS SPRING UPPER |
| 16 | 2 | 1152004 | SPACER, ROD END |
| 17 | 1 | 1157002 | ADJUSTMENT LOCK NUT |
| 18 | 1 | 1157003 | TUBE, KNURLED ADJUSTMENT |

HIX MANUAL SCREEN PRINTERS

CONVERTIBLE SERIES



**4 color / 2 station
Bench Printer**



**4 color / 4 station
Bench Printer**

- Back clamps
- Micro adjustment
- 15x15 wooden shirt platen
- Dual machined rotary print wheel
- Cast and machined head assemble with full parallel off-contact adjustment

Rotary print wheel and head assembly can be put on a floor mount base to upgrade to Rally Series Premier Printer.

RALLY SERIES



**4 color / 4 station
Premier Rotary Printer**



**6 color / 4 station
Premier Rotary Printer**



**6 color / 6 station
Premier Rotary Printer**

- Back clamps
- Aluminum shirt platen
- Micro adjustment
- Dual machined rotary print wheel
- Cast and machined head assemble with full parallel off-contact adjustment

Back clamps can be replaced with side clamp to upgrade to Cruise Series Premier Printer.

HIX MANUAL SCREEN PRINTERS

CRUISE SERIES



6 color / 4 station
Premier Rotary Printer



6 color / 6 station
Premier Rotary Printer

- Side clamps
- Aluminum shirt platen
- Micro adjustment
- Dual machined rotary print wheel
- Cast and machined head assemble with full parallel off-contact adjustment

Air Assist kit can be added to upgrade to GT Series Premier Printer.

GT SERIES



6 color / 4 station
Premier Rotary Printer



6 color / 6 station
Premier Rotary Printer

AIR ASSIST



- Side clamps
- Aluminum shirt platen
- Micro adjustment
- Dual machined rotary print wheel
- Cast and machined head assemble with full parallel off-contact adjustment
- Air Assist

WARRANTY

(Effective 3/1/2020)

HIX will automatically register the equipment on the date it was shipped to you or your distributor. If the equipment was not purchased directly from HIX, but through a distributor (either domestic or foreign), please keep a copy of their sales invoice showing the serial number and date it was sold/shipped to you with this warranty. In this case, we will use the distributor's invoice date as the beginning warranty date. **STAPLE A COPY OF YOUR PROOF OF PURCHASE TO THIS WARRANTY** and keep in a safe place to provide verification of your warranty should a problem occur. Thank you.

Please fill in the following information and attach a copy of your receipt for your records.

Date Purchased: _____ From: _____
Model #: _____ Serial #: _____

This warranty applies to equipment manufactured by the HIX Corporation (HIX), Pittsburg, Kansas, U.S.A. HIX warrants to the original purchaser, its Ovens and Dryers, Heat Transfer Machines, Textile Printers, Spot Heaters, and Exposure Units against defects in workmanship and material, except for wear and tear for a period of "One Year" from the date of purchase. HIX warrants Accessories for a period of 90 days from the date of purchase. doughXpress products are covered under separate warranty.

In the event of a defect, HIX, at its option, will repair, replace or substitute the defective item at no cost during this warranty period subject to the limitations of insurance and shipping costs stated below (excludes labor).

In the case of heat transfer presses (except the Hobby Lite and Large Format presses), HIX warrants the heat casting for the "Life" of the machine for the original purchaser. If a part becomes obsolete at the time for repair, and/or cannot be reasonably substituted for, HIX will credit, at half the then current list price or last recorded price, only that part toward a new machine or any product HIX offers. This credit offer shall be the sole responsibility of the HIX Corporation in the event of an obsolete part.

This warranty does not cover belts, rail tape, pads, mug wraps, canvas, rubber blankets, bulbs, glass. Warranty does not cover damages due to accident, misuse/abuse, alterations or damage due to neglect, shipping or lack of proper lubrication or maintenance. HIX shall not be responsible for repairs or alterations made by any person without the prior written authorization by HIX. This warranty is the sole and exclusive warranty of HIX and no person, agent, distributor, or dealer of HIX is authorized to change, amend or modify the terms set forth herein, in whole or in part.

In the case of a problem with the equipment identified herein, HIX Corporation should be contacted during regular business hours to discuss the problem and verify an existing warranty. HIX personnel will assist the customer to correct any problems which can be corrected through operation or maintenance instructions, simple mechanical adjustments, or replacement of parts. In the event the problem cannot be corrected by phone, and upon the issuance of a return authorization by HIX, the equipment shall be returned to HIX or an authorized service representative. All insurance, packaging and shipment/freight costs are solely the responsibility of the customer, and not that of HIX, and HIX shall not be responsible for improper packaging, handling or damage in transit. Contact HIX customer service for complete return authorization information. Correct shipping boxes are available from HIX.

This expressed warranty is given in lieu of any and all other warranties, whether expressed or implied, including but not limited to those of merchantability and fitness for a particular purpose, and constitutes the only warranty made by HIX Corporation.

In no event shall HIX's liability for breach of warranty extend beyond the obligation to repair or replace the nonconforming goods. HIX shall not be liable for any other damages, either incidental or consequential, or the action as brought in contract, negligence or otherwise.

This warranty gives you specific legal rights and you may also have other rights which vary from state to state.



1201 E. 27th Terrace • Pittsburg, KS 66762 • U.S.A.
Web site: www.hixcorp.com • Phone: (800) 835-0606 • Fax: 620-231-1598
E-Mail: customerservice@hixcorp.com • E-Mail: sales@hixcorp.com