

SCHEDA COMPONENTI

POS.	DESCRIPTION	FILE NAME	MATERIAL	QTY
1	ASTA D10 X 60,9 FIL M10X1 TRN	AST000440009TRN	CW617N-UNI-EN-12164	1
2	CESTELLO (2) CON FILTRO 8/12 SEC HOSTAFORM	CPL016460039STP	HOSTAFORM	1
3	HI/335-GACO PICC 17,65 X 8,33 X 4,7 SEAEP80N01 PEROX	GUS016090056STP	SEAEP80	2
4	MANOPOLA D 40 X 25 TORNITO	MAN003390000TRN	CW617N-UNI-EN-12164	1
5	MOLLA ASSIALE D19,5 H40 FILO1,3 7 SPIRE	MOL002160025AVL	AISI302	1
6	O-ring Ø17x1.5	GOR002170051STP	EPDM	1
7	O-ring Ø20x2.5	GOR002640051STP	EPDM	1
8	O-ring Ø6x2,5	GOR002120051STP	EPDM	1
9	OTTUR ASS OT STD GRZ C/GACO	2OT00010001GR		1
10	OTTUR D15 H14,5 FORO M6 SEDE GACO TRN	MIN016050009TRN	CW617N-UNI-EN-12164	1
11	PULSANTE 103C OT STD CRM	2PS00320001CR		1
12	Torretta per vitone standard	CPL016550039STP	POM_HOSTAFORM	1
13	VITONE D26 MARC ASS OT STD C/GACO E ORING CRM	2VI00010001CR		1
14	VITONE W26X19 H23,5 C/DATA TRN	MIN003550000TRN	CW617N-UNI-EN-12165	1

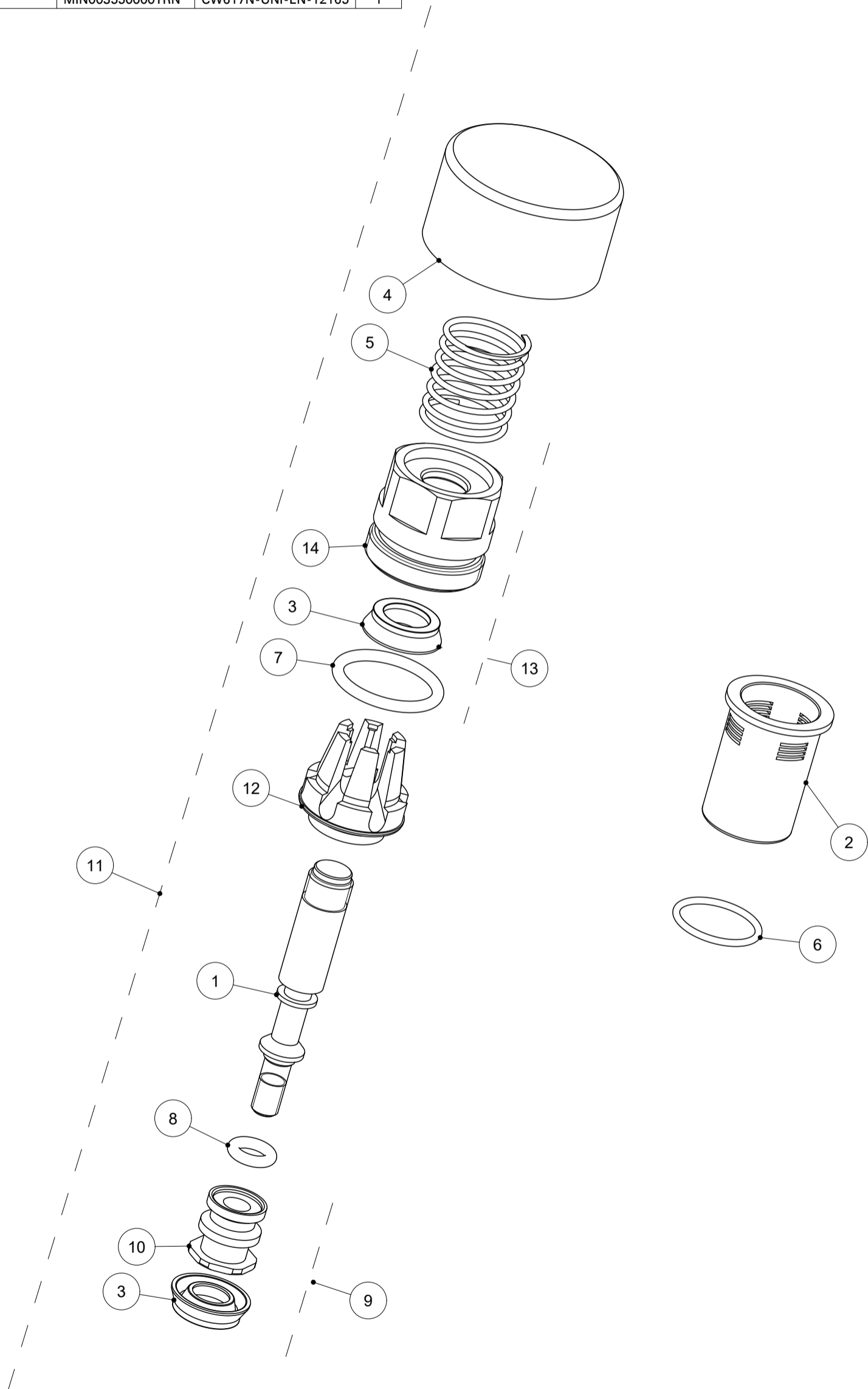

- 103CV 8/12

RIC VITONE ASS 103C 8/12SEC

MCM srl Via dell'acacia 54-56 - 28021 - Borgomanero (NO) - Tel. +39 0322 843060 www.mcmtaps.it

Formato / Format  
**A3**

Dis. RIC019420005ASS

Il presente disegno a termine di legge non può essere reso pubblico o riprodotto senza l'autorizzazione scritta di mcm srl