

SE110P

Ceiling Exhaust fan with plastic blower



Starling

Next Generation Fans



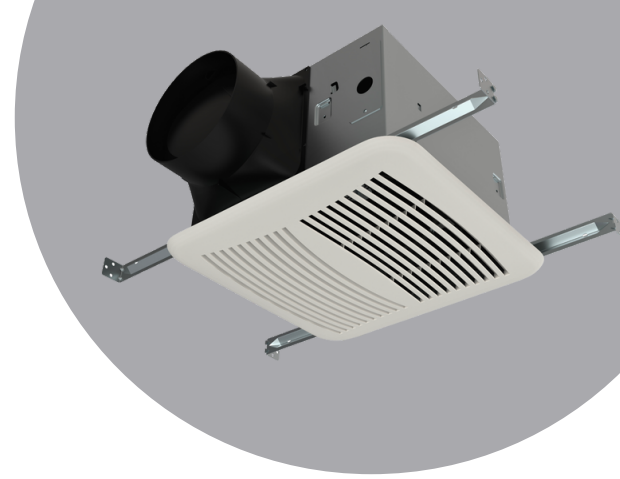

SE110P Specification

Description:

The ventilating fan is designed for quiet and efficient air exhaust and can be mounted on either the ceiling or wall. The SE series is both HVI and ENERGY STAR certified, ensuring high performance. Equipped with a capacitor start motor, known for its exceptional efficiency and long-lasting reliability, this fan has undergone ETL evaluation and conforms to UL and cUL safety standards. What sets this fan apart is its unique plug and play concept, allowing the addition of accessories such as a motion sensor, humidistat, light, or speed controller without requiring a fan replacement.

Housing:

The housing is constructed from rugged 26 GA galvanized steel, ensuring durability. It features a detachable 6-inch polymeric resin collar that includes a lightweight built-in backdraft damper. The double hanger bar mounting brackets are adjustable up to a 24-inch span, enabling ideal positioning for installation.

Motor/Blower:

The plug-in permanently lubricated motor is engineered for continuous operation, and energy efficiency as listed by ENERGY STAR . The power rating is 120 volts and 60 Hz. This fan is ETL and cETL listed for tub/shower enclosure use when connected to a GFCI branch circuit. The motor also includes a built-in overload disconnect for safety and to prolong motor life. Our Premium series operates at lower RPMs, providing quieter operation.

Grille:

The Premium grille boasts a low-profile design that combines elegance with simplicity. Constructed from rugged polymeric resin, it ensures long-lasting durability. The grille is equipped with torsion spring clips, facilitating even mounting.



Typical Specification:

The ceiling ventilator features a corrosion-resistant galvanized steel housing with 4-point mounting capability. It is ducted to a roof vent or wall cap using 6-inch round pipe. The blower assembly is removable and incorporates a centrifugal-type blower wheel and a permanently lubricated motor designed for continuous operation. The air and sound delivery meet the HVI certified ratings, as indicated in the attached fan curves. STERLING ventilators feature a permanent split capacitor motor, which significantly improves efficiency and qualifies them to carry the ENERGY STAR label.

Compatible with:

- LightKit LEDG-SE
- Humidistat Kit
- Speed Controller Kit
- Motion Sensor Kit
- RDF3 Fire Radiation Damper

Model Number	SE110P	
Static pressure in inches w.g.	0.1	0.25
Air Volume (CFM)	110	100
Noise (sones)	0.9	1.2
Fan Wattage	32W	32W
Duct Diameter	6"	
Power rating (V/Hz)	120/60Hz	

