

INSTALLATION MANUAL

AutoSlide

AutoSlide iLock

AutoSlide Elite

AutoSlide Elite iLock

CONTACT



WEB

autoslide.com



Email

support@autoslide.com



Phone

(833) 337-5433



AUTOSLIDE™

WELCOME

Congratulations on the purchase of your new AutoSlide automatic door opening system. Please carefully read through these instructions before beginning the installation. This manual is designed for the installation of the AutoSlide Standard, Standard iLock, Elite, and Elite iLock systems onto a single sliding panel door.

We hope AutoSlide improves the quality of your life by providing easy access and convenience throughout your home.



Hi,

I'm an IT specialist from Autoslide North America. I've installed thousands of AutoSlide units on all types of sliding doors in many different situations.

We've included all the parts you'll need to automate your door and listed the tools required for easy installation. If you run into any problems, please email us at: support@autoslide.com.

For faster technical support, visit us online at www.autoslide.com/support

We are here to help you.
- Team Autoslide

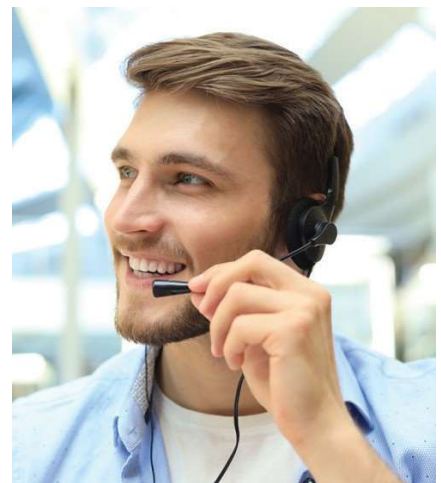

CONTENT

01

IN THE BOX

PAGE 3 - 5

02

OVERVIEW

PAGE 6 - 6

03

PREPARE

PAGE 7 - 13

04

INSTALL

PAGE 12 - 16

05

OPERATE

PAGE 17 - 24

06

FINALIZE

PAGE 25 - 26

07

REHANDING

PAGE 27 - 30

08

TROUBLESHOOTING

PAGE 31 - 32

09

POLICY

PAGE 33 - 35

IN YOUR BOX

AUTOSLIDE DRIVE SYSTEM

Contains the motor and electronic controller that allows you to calibrate and control the door opening. A metal cover protects and conceals the AutoSlide's electronic components.

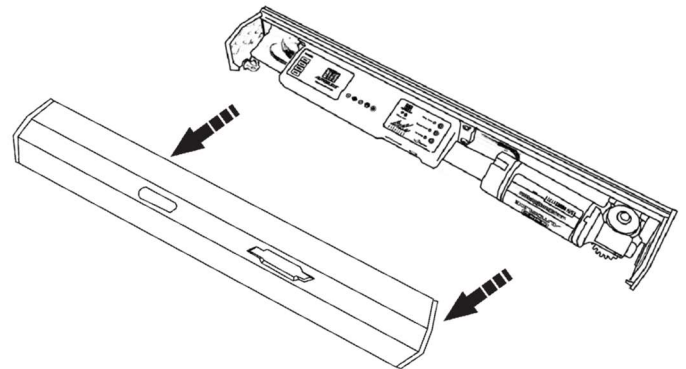

L-MOUNTING ADAPTER BRACKET

Metal bracket used to create a head mount above the door when one is not present. Bracket is adjustable using sliding holes for screws.

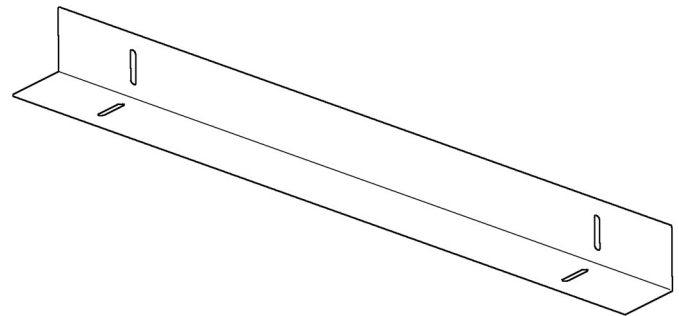

FRICTION TESTER

Used to test your door's drag force. Does not apply to Elite and Elite iLocking AutoSlides.

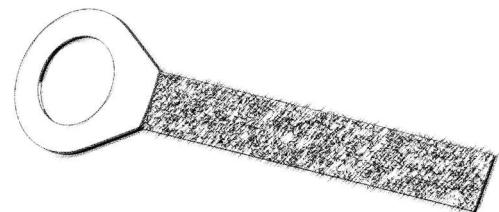

POWER PACK

Converts AC power source to 24 volts DC for AutoSlide system.

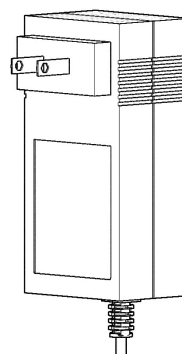

Standard Power Pack (top),

Elite Power Pack (right)

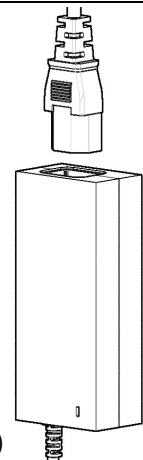

01

IN THE BOX

CHECK BEFORE PROCEEDING

IN YOUR BOX

SCREWS AND TOOLS

Use the included screws to mount the AutoSlide drive unit. The small flathead screwdriver is used to adjust the DIP switch positions, and the Allen key may be used to re-hand the drive unit if needed. Note that additional screws may be needed depending on your door.

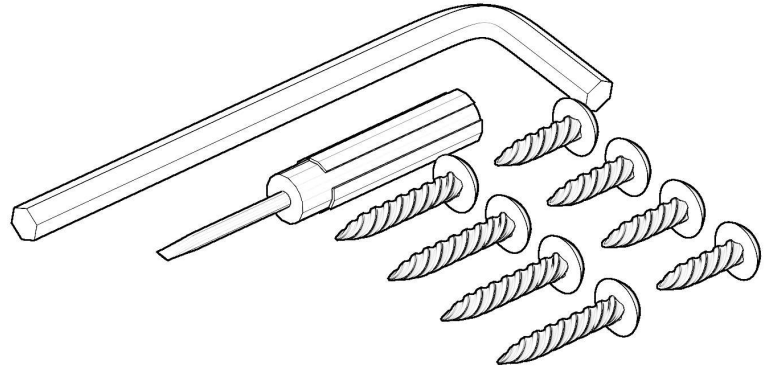

RACK

The track mounted to your active sliding door panel. The motor gear uses the rack to push and pull your door open and closed. Each track is 20" long, and two are included with every kit.

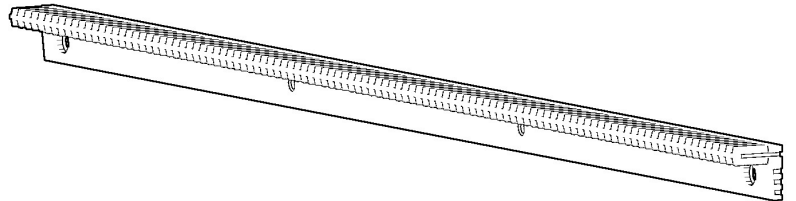

RACK SCREWS

Use these screws and endcaps to attach the rack to your active sliding panel.

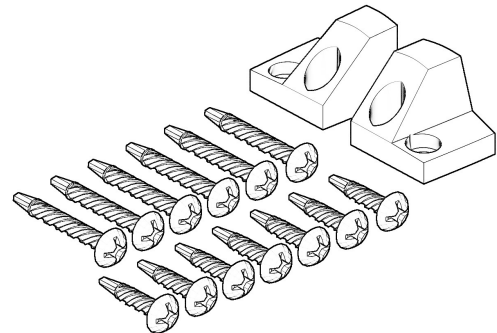

WALL PUSH BUTTONS

Used to activate the AutoSlide system to open and close the door. These buttons connect wirelessly. Two are included with every system.



WHAT YOU'LL NEED

SCREWDRIVER

A No. 2 flat head screwdriver and Phillips head screwdriver are recommended.

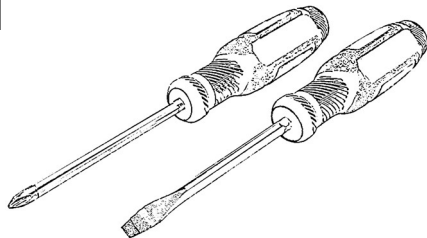

DRILL

The unit and tracks will need to be drill mounted to the door. An assortment of drill bits is recommended.

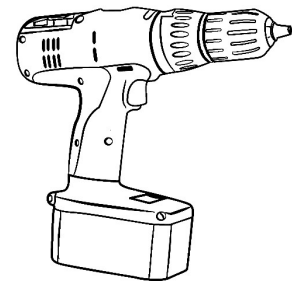

HACK SAW

Needed to cut off any excess rack once sized to the sliding panel width.

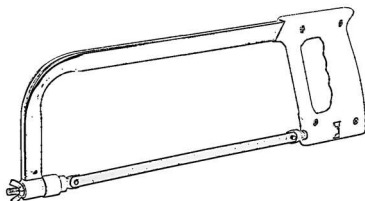

TAPE MEASURE & MARKING PENCIL

Needed for marking and measuring drill holes, rack lengths.

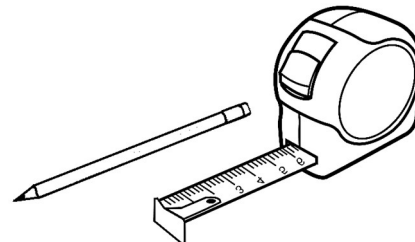

Depending on the door and mounting options, additional materials may be needed to attach the system to the door. This may include shims to extend out the rack or move the unit down, drywall anchors or concrete anchors, specialized screws, etc. For mounting assistance, please contact Autoslide support staff directly with pictures of the door and frame.

MOUNTING MEDIUM	RECOMMENDED FIXING METHOD
DRYWALL	DRYWALL ANCHORS
MASONRY	CONCRETE ANCHORS TAPCONS
VINYL, WOOD	NORMAL SCREWS SELF-TAPPERS
METAL	DRILL PILOT HOLE & SELF-TAPPERS

STAGES OF A STANDARD INSTALL INCLUDE...



Approximately
90 minutes

PREPARE

To prepare for the install, you will need to assess the scenario: check the door's readiness, test the drag force of the door, plan how the system will mount, and gather any necessary tools and materials.



INSTALL

During the install, you will mount the AutoSlide drive system to the door frame or floor, then attach the rack to the sliding door panel.



OPERATE

To operate your door, you will need to connect the power and program the Controller. Once connected, you can then synchronize the Wall Push Buttons and/or other sensors to the Controller and test how the door operates.



FINALIZE

Once installed and set up, place the cover back on the drive unit and conceal cables as desired. The unit can also be concealed and covered with a faux valence or access panel.

02

OVERVIEW

STAGES OF A STANDARD INSTALL

BEFORE YOU BEGIN

You will need a power point (outlet) near your door to plug in your AutoSlide unit. Confirm a power point is near the installation position and can be reached by the included power cable. Otherwise, a *heavy duty* extension cable or AutoSlide extension cable can be used.

Note: If necessary, contact a professional electrician to install a new outlet or electric cabling.

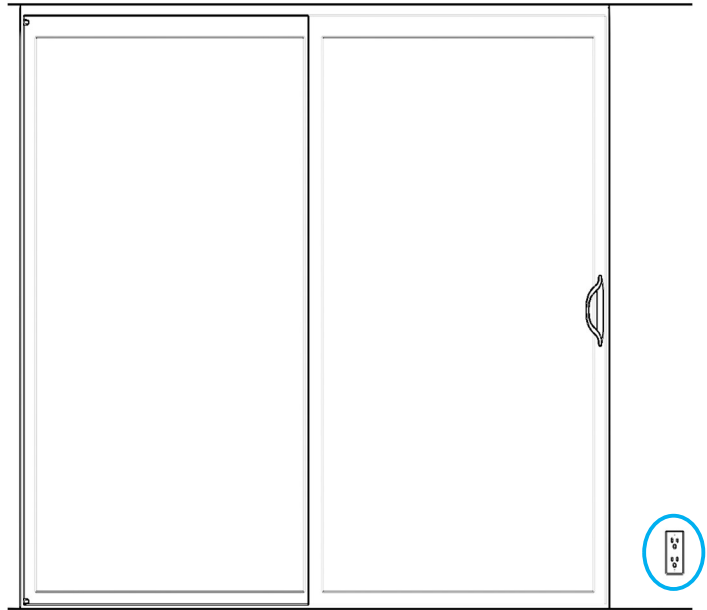

WORKING ORDER

Assess the operating condition of your door before installing the AutoSlide. Check the door:

- Rolls smoothly and is level. The best way to check if the door is level is by closing the door, leaving a finger size gap between door and jamb. Run your finger along the gap to see if it is even from top to bottom.
- Track is clean and is free of foreign objects. If necessary, use a silicone or aluminum based lubricant to reduce resistance.

Note: If the door is not sliding smoothly or level, contact a local professional to perform maintenance.

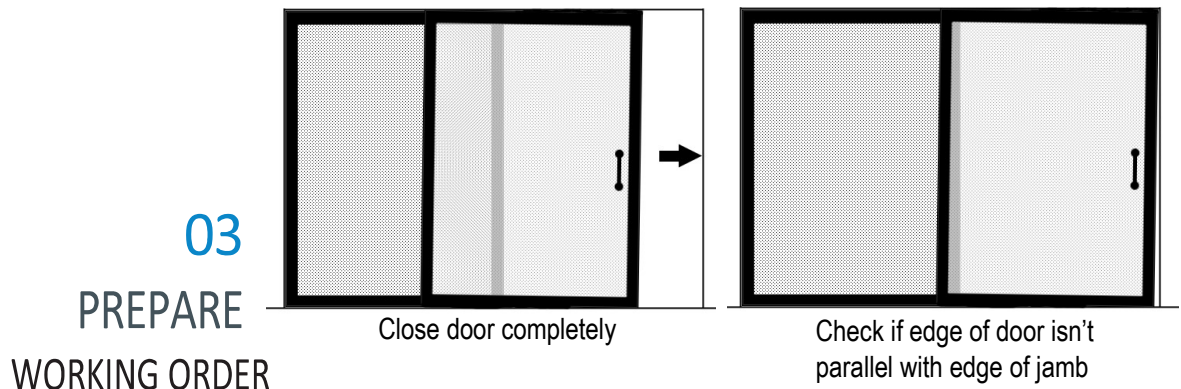

THE FRICTION TEST

A simple friction test is used to confirm the drag force of your door. This will determine if the Standard Motor or the Elite Motor is needed to open and close your door. Your sliding door must be in proper working condition and run freely along its track.

1. Close the door.
2. Wrap/loop the friction tester around the sliding door handle and secure the Velcro.
3. Pull on the Friction Tester with even force to fully open and close the door **3 times**. Use the same force as you would to normally open the door and assess.

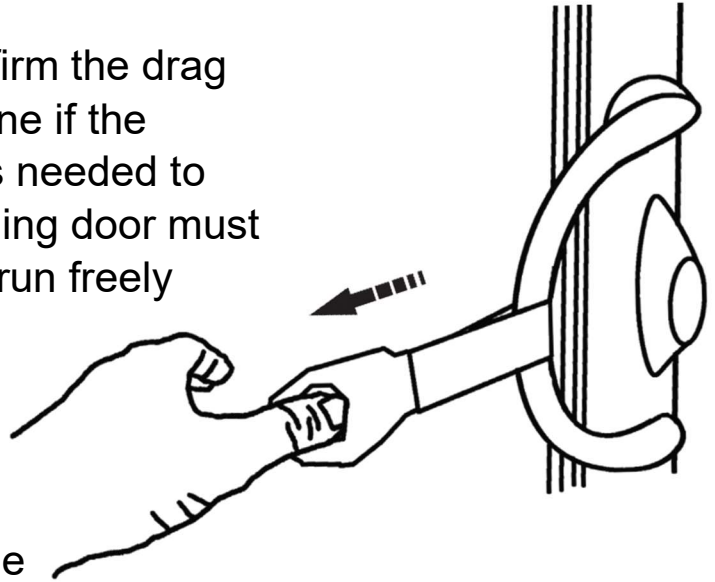

The test strip is only used on **Standard** units. If you already have an **Elite** unit, this test can be skipped.



Standard Motors will have a **silver** barrel



Elite Motors will have a **black** barrel

If the Velcro... Then...

Stays intact

Your door is ready for the AutoSlide system to be installed. Go to the next page.

Breaks during the test

Your door is not yet ready for the AutoSlide to be installed. You may need to improve the sliding action with some maintenance.

Note: If the door is in good working order but is too heavy, you must upgrade to an Elite Motor.

Contact Autoslide about upgrading at (833) 337-5433.

DRIVE MOUNTING OPTIONS - TOP

Inside vs. Outside Mount

The drive system's preferred mounting location is to the head above the door. The unit may be mounted inside or outside and is determined by the track of the active panel (i.e. active panel on inside track requires mounting inside the home). When possible, an inside mount is the preferred location.

TOP MOUNT OVER FIXED PANEL

This is the preferred mounting option when the sliding panel opens to the left when viewed on the side of the active panel (as shown).

If the system must be mounted over the fixed panel (for clearance/aesthetic purposes) and the door opens to the right, it is necessary to rehand the unit (see Section 07 prior to installing).

ADAPTER BRACKET

If the door header doesn't have enough depth to mount the unit onto it, you can use the included mounting adapter "L" bracket to facilitate a mount directly to the wall. The bracket can be used in a variety of ways, including as reinforcement.

In some situations, it may be necessary to drill new holes into the unit base. If so, take great care to not damage any hardware or cables.

VERTICAL GAP

If the motor wheel can't vertically meet the track (and the track is placed as high as possible), use a block of wood or metal to shim the unit down closer to the track. It will likely be necessary to mark and pre-drill your holes in the shim.

Top Mount Over Active Panel

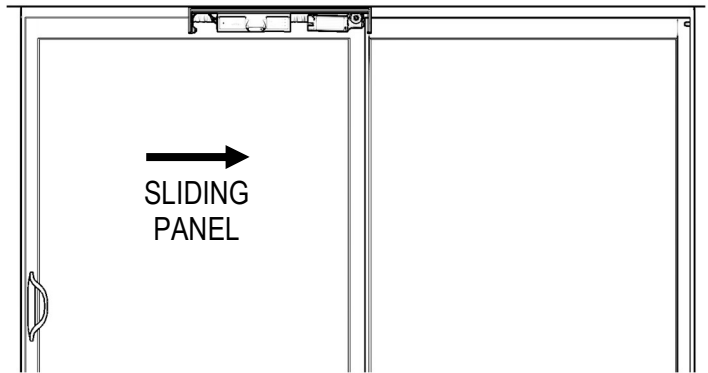

Top Mount Over Fixed Panel

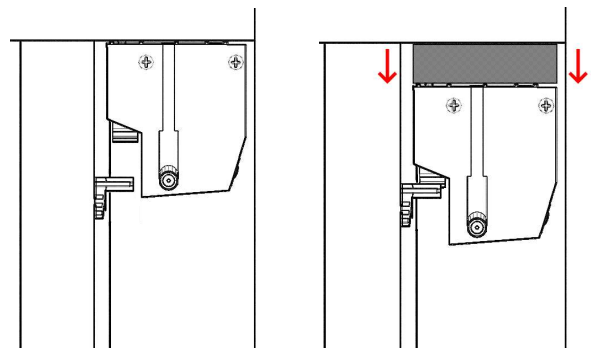
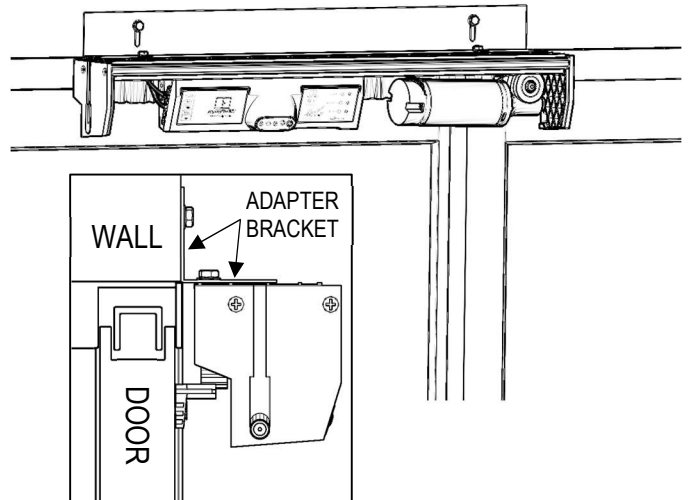
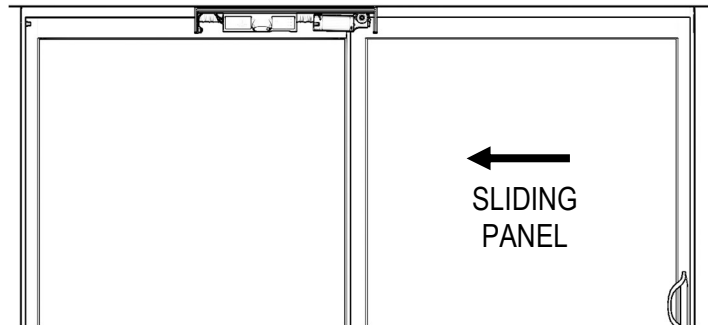

DRIVE MOUNTING OPTIONS - BOTTOM

BOTTOM MOUNT UNDER FIXED PANEL LEFT-HANDED DOOR

If the drive system cannot be mounted at the top of the door frame, it can be mounted to the floor. Floor mounting should be used as a final option only, if top mounting isn't possible. Use this example if your door opens left to right.

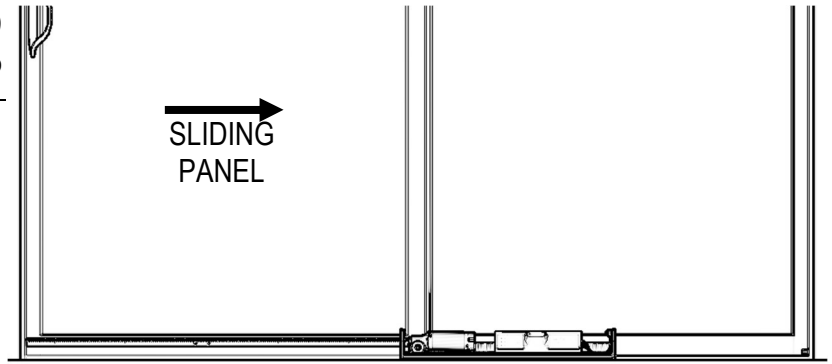

Often clearance can be an issue when installing tracks for a floor-mounted system. Note that the tracks can be installed flange up or flange down to avoid drilling into the glass (see figures to the right).

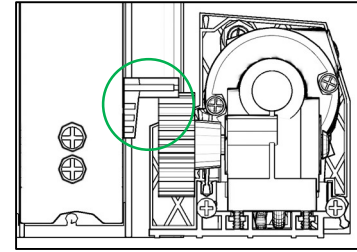
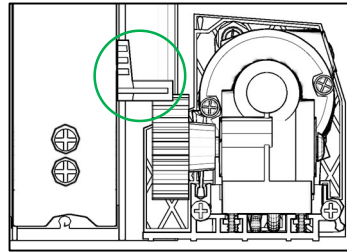

BOTTOM MOUNT UNDER FIXED PANEL RIGHT-HANDED DOOR

If the door opens from right to left, floor mounting the unit in its default configuration will cause it to extend into the door opening; in this case, the unit must be re-handed (see below) so the unit body stays under the fixed panel.

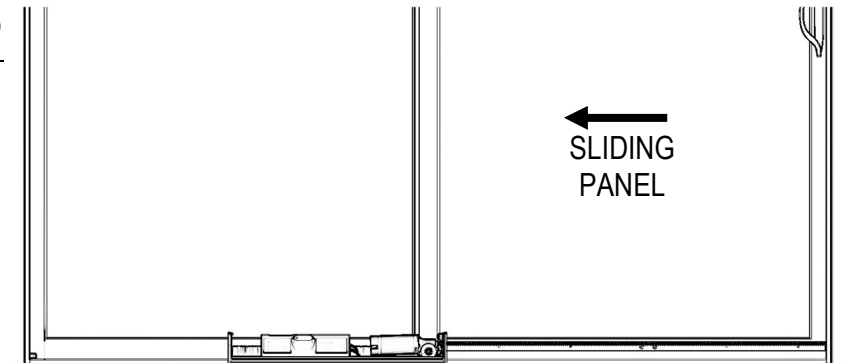

REHANDING

If floor mounting on a right-handed door, it is required to **re-hand** the system (reversing the position of the motor and control panel). Refer to Section 07 to rehand *before* installing.

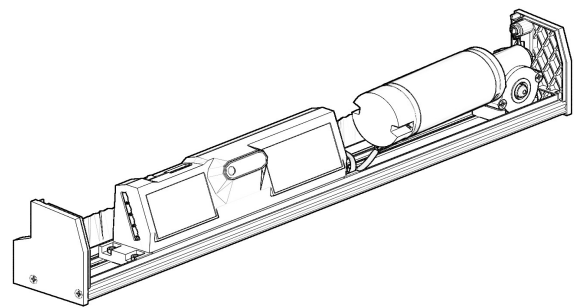

VERTICAL GAP

If the motor wheel can't vertically meet the track (and the track is as low as possible), use a block of wood or metal to shim the unit up closer to the track. It will likely be necessary to mark and predrill your holes in the shim.

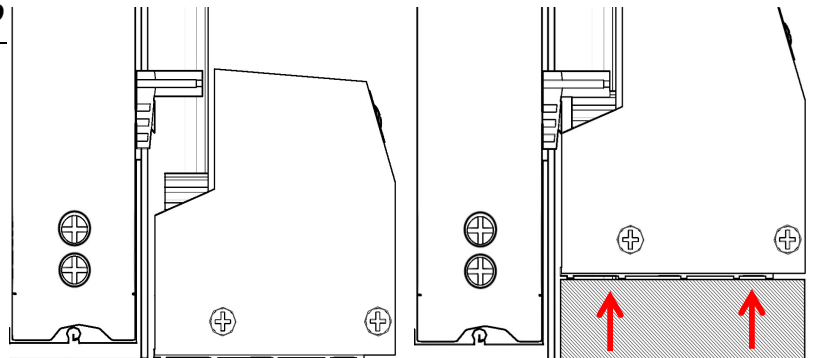

TRACK MOUNTING OPTIONS

Once the drive system is mounted, the tracks can be securely mounted, using a drill, to the sliding door panel engaging the motor wheel. The tracks can be mounted **flange up** or **flange down** depending on clearance.

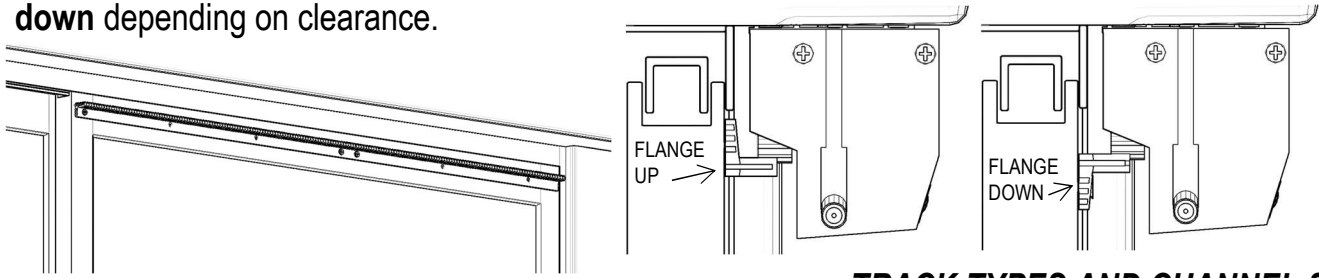

TRACK TYPES AND CHANNEL SIZE

The AutoSlide kit by default includes regular tracks (shown below on the left). Slimline tracks (right) are available upon request before purchasing and are designed for barn and pocket doors.



LIMITED DOOR FRAME

If the top frame of the sliding panel is too thin, you can mount a **metal bar** to the sides of the sliding panel. Then mount the tracks to the bar. The bar should span the full width of the sliding panel.

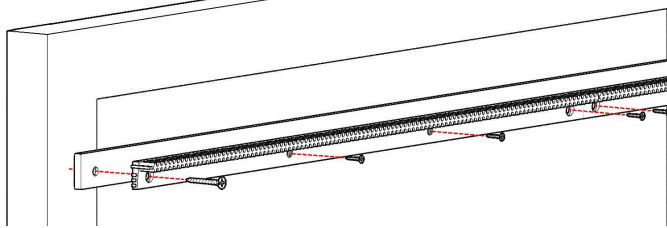
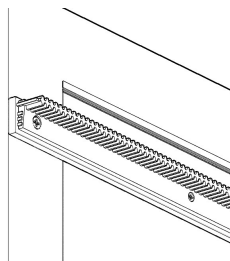

If there isn't enough frame on the door's sides to bar mount the tracks, they can also be secured to the door using **3M VHB** industrial tape. Contact a specialist on the recommended tape for your door material. If adhering to glass, seal the glass first to prevent moisture weeping into tape.

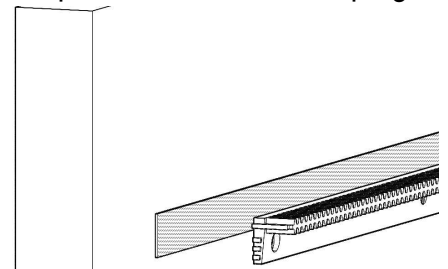

HORIZONTAL GAP

If the tracks don't meet the motor wheel due to a horizontal gap, use spacers or shims to extend out the track.

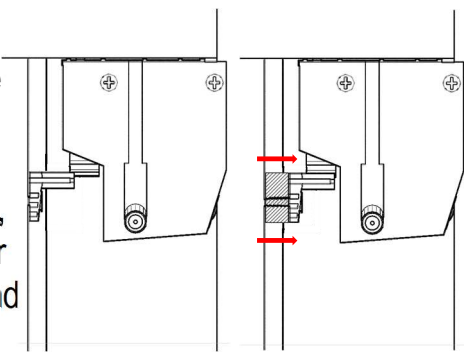

Alternatively, motor wheels with longer pinions are available on request when purchasing. The longer pinion will extend the wheel up to **1"**.

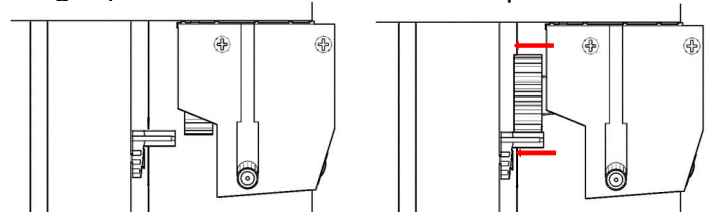

DRIVE MOUNTING

This section will show the **top mount** installation process onto a **right-handed** door. Please note the exact process may vary; refer to the previous section to prepare your door prior to starting installation.

1) Mount the drive system to the door's header using the three holes on the back of system base like shown.

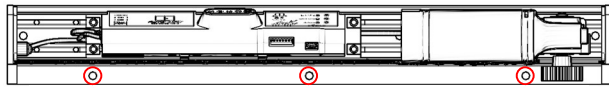

Bottom view, primary mounting holes circled in red

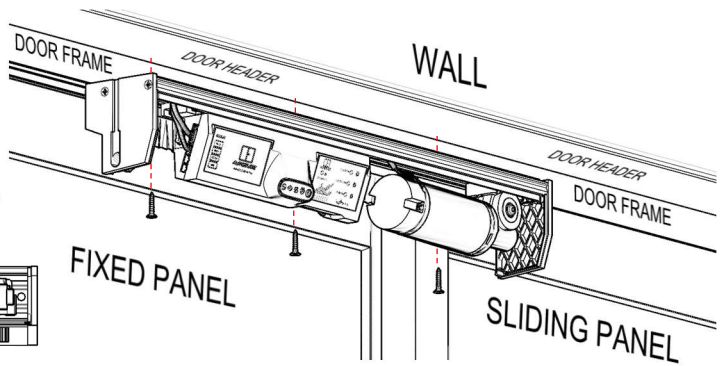

- Allow for **3" / 75mm** overlap of the AutoSlide unit and the back of the sliding panel when the door is fully closed.
As a guideline, the center of the motor wheel should be $1\frac{3}{8}$ " / 35mm from the back edge of the sliding panel (regardless of mounting placement or door orientation).

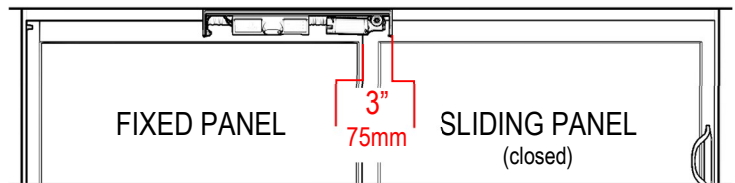

- Ensure the motor wheel will remain within the edges of the sliding panel when fully opened/closed. If the motor wheel goes past the sliding panel's front edge when opened fully, the overlap described above can be reduced to $2\frac{3}{8}$ " / 60mm (but track endcaps **cannot be used** in Step 2).

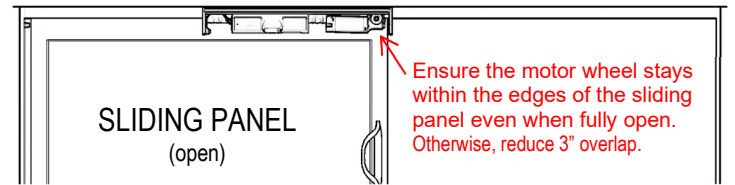

- The *inset edge* of the unit endcap (see diagram to right) should be **21mm to 25mm** from the sliding panel's surface (plus the width of any shim that will be used with the tracks).

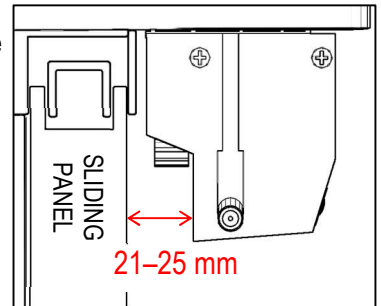
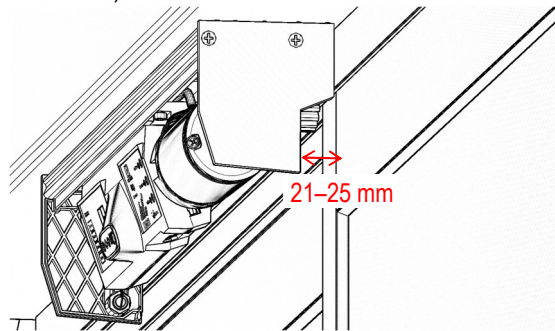

If the system is mounted as close as possible and this measurement exceeds 25mm, the tracks must be shimmed out as depicted to the right (or a longer motor wheel pinion used).

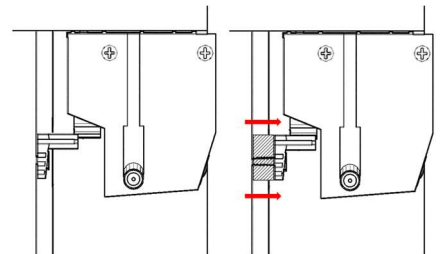

04

INSTALL

INSTALLATION PROCESS

DRIVE MOUNTING

- 1) ○ The bottom of the motor wheel should reach below the bottom edge of the door frame, so that the motor wheel can meet the track once mounted.

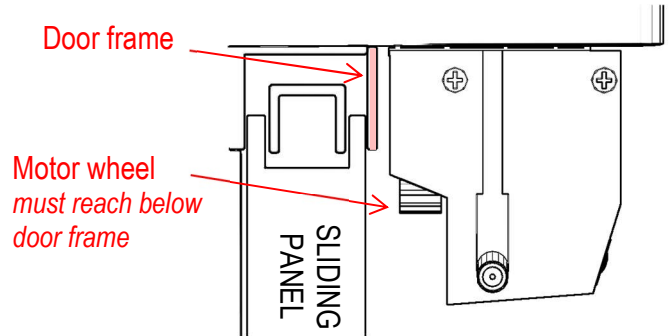

- If the motor wheel doesn't reach below the edge of the door frame, there will be a vertical gap between the wheel and track. In this case, the unit will need to be shimmed down.

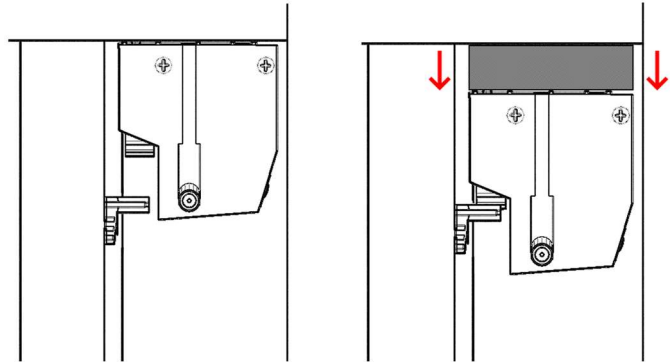

Note: If the top header doesn't have enough width to mount the system, the adapter bracket can facilitate a direct wall mount (as shown). Note the unit can be adjusted both vertically and horizontally with the bracket. This adapter bracket can also be used as reinforcement, and can be mounted either flange up or flange down.

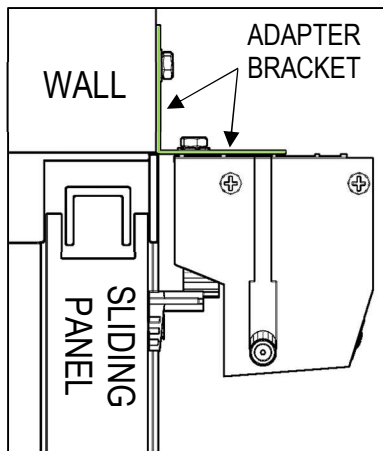
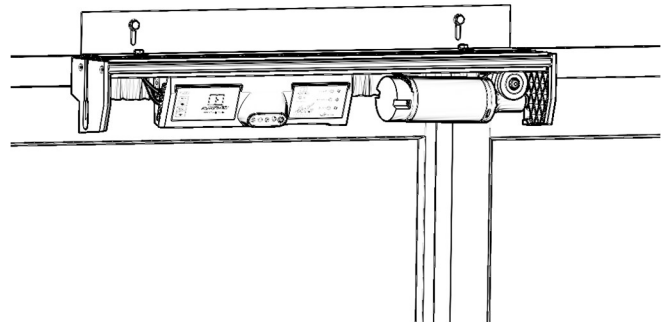

Mounting adapter (green) used flange up, drill mounted to wall

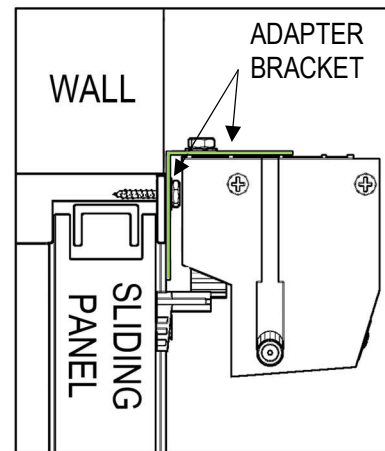

Mounting adapter (green) used flange down, drill mounted to door frame; do not drill into the rail for the sliding panel itself

TRACK CUTTING

- 2) a) Join the tracks together using the grooves at the ends.

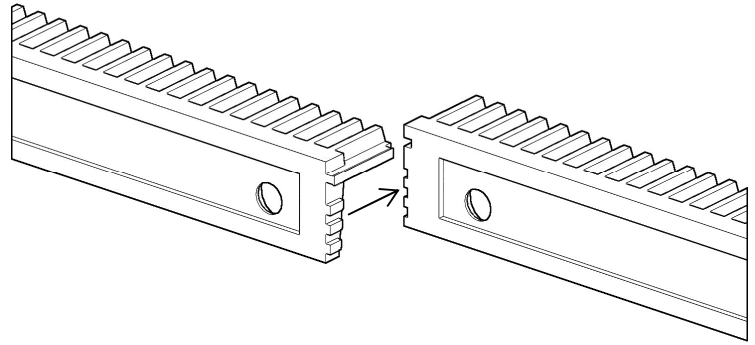

- b) Fully close the door into the jamb. Measure the **exposed** width of the sliding panel (from the back edge of the sliding panel to the start of the jamb). Use a hacksaw to cut the tracks to match this width.

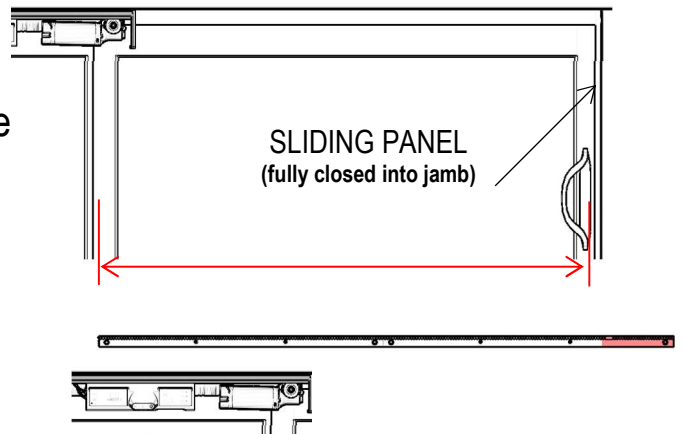

Note: If the location of the cut is not near a mounting hole on the track, you can either drill a new hole into the track or use one of the optional track endcaps for support. Four additional teeth may need to be cut from the track for each endcap. If using track endcaps, ensure the motor wheel **does not hit** an endcap (whether fully open or fully closed) once the tracks are mounted.

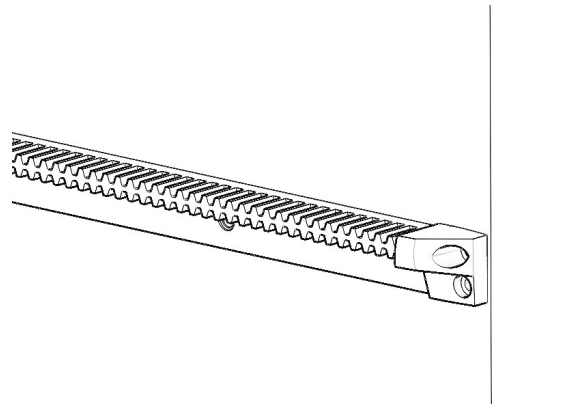

Note: If the total track length is shorter than the sliding panel width, the AutoSlide will still be able to automatically open the door partially. In this case, a door stopper should be installed to prevent the sliding panel from opening too far and running off the AutoSlide track.

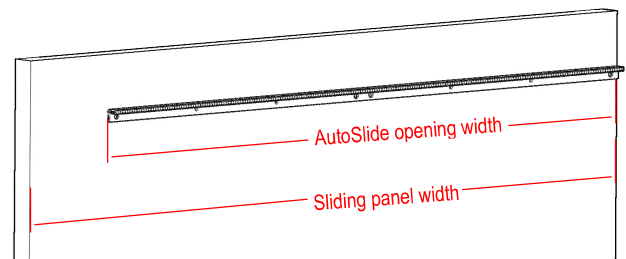

TRACK MOUNTING

- 3) a) Hold the track to the sliding door panel (closed). Align the edge of the track with the back (non-leading) edge of the door as shown.

Note: The tracks can be mounted flange up (see below) or flange down (see below right). Take great care to note how far your glass goes into your panel frame, and mount accordingly to avoid drilling into the glass.

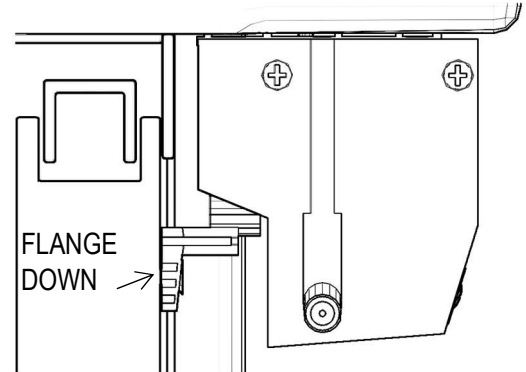
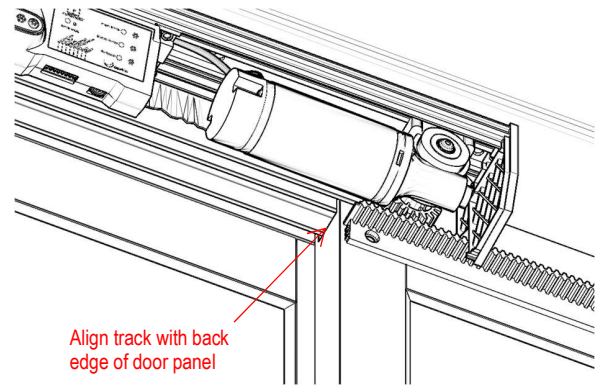
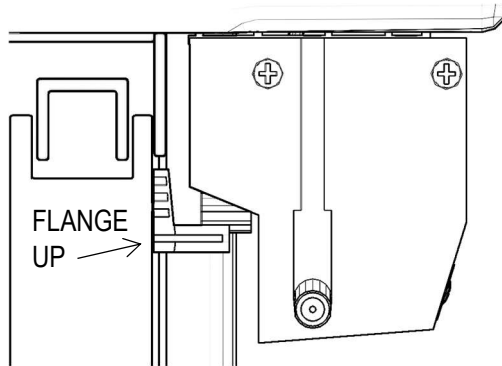

- b) Keeping the track in place relative to the sliding panel, open the door to the first position where a track mounting hole is accessible and close to the motor wheel.

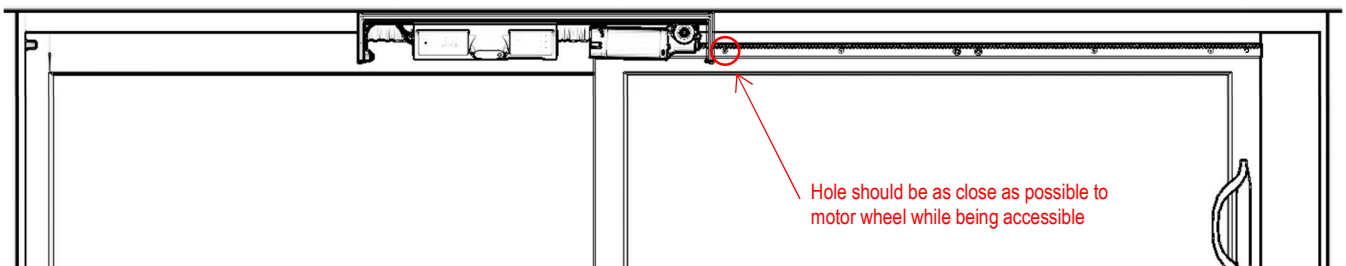
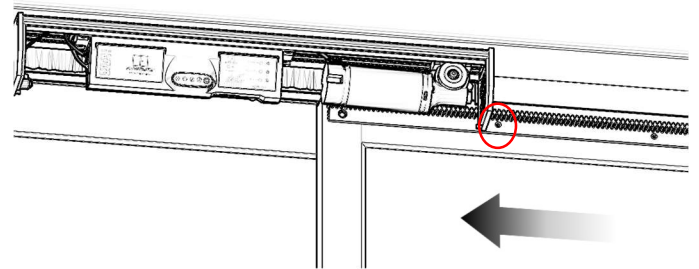

- c) While holding the track up tightly to the motor wheel, drill in the first screw.

If the tracks aren't installed with enough pressure on the motor wheel, the motor wheel may grind against the track during setup or use.

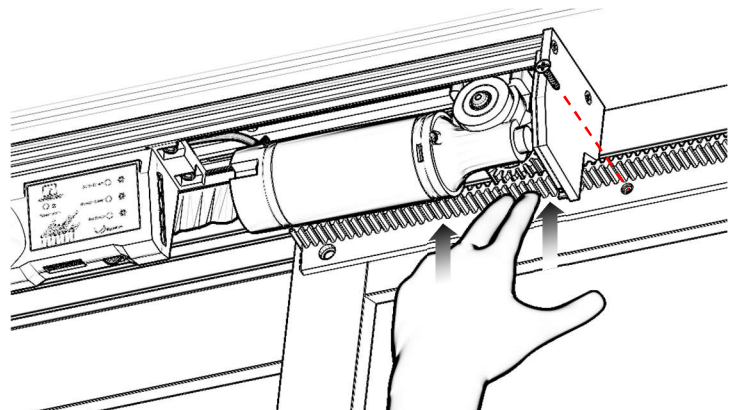

TRACK MOUNTING

- 3) d) Once secure, slide the door so that the next track mounting hole is close to the motor wheel. While pushing upwards on the track to the motor wheel, drill in the next screw.

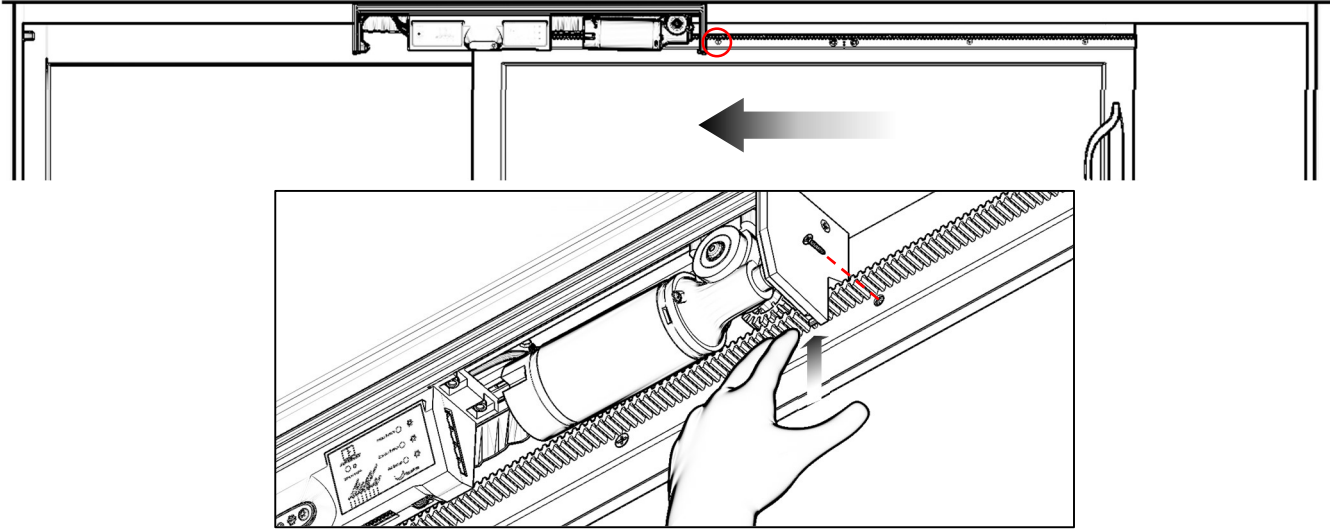

- e) Repeat for remaining mounting holes until track is entirely mounted to sliding panel. Be sure to firmly hold the track up to the motor wheel each time.

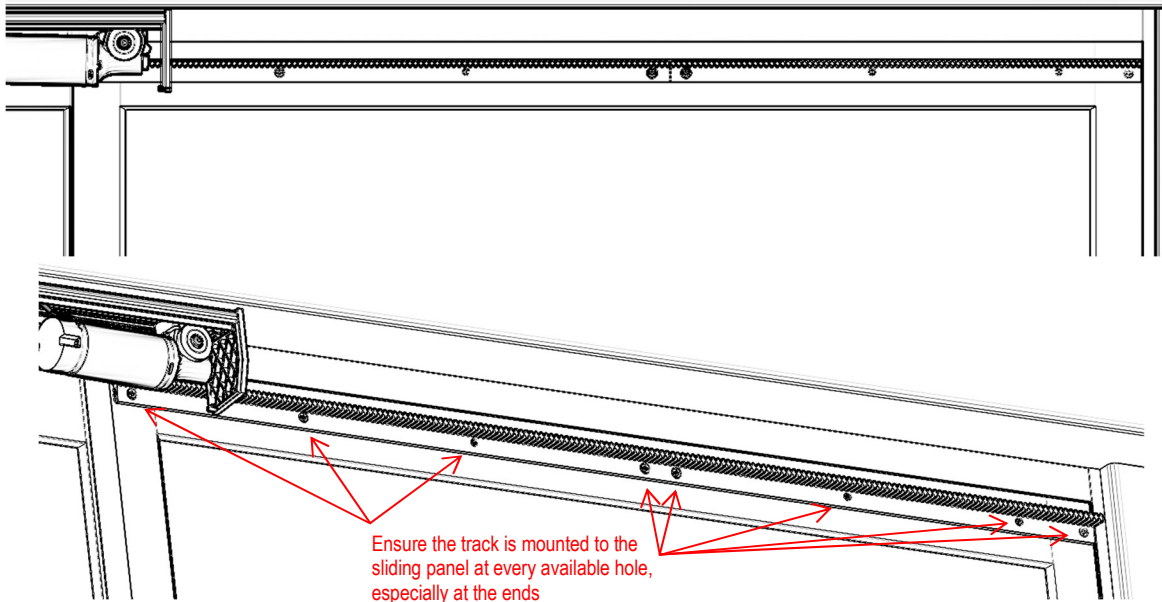

- f) Once the track is attached to the door, open and close the door manually to ensure the door runs smoothly without any interference. Ensure the motor wheel is consistently engaging with the track in all positions.

LOCKING, MODE, AND SENSOR PORT GUIDE

The AutoSlide Standard iLock and Autoslide Elite iLock include a dynamic breaking lock built into the motor. This will lock the door when closed, provided the AutoSlide is in a locking mode. An iLock system will always include a chrome cylindrical segment towards the end of the motor barrel:

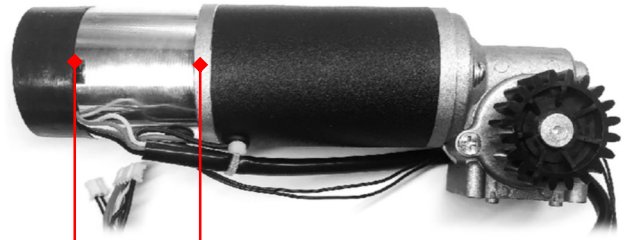

Elite iLocking Motor

The AutoSlide system uses four unique modes:

Green / Auto Mode

A mode for everyday human use. Pet sensors are disabled, open-assist is enabled, and the door doesn't lock. Most commonly used mode.

Blue / Stacker Mode

By default, keeps the door fully open. A sensor connected to the Stacker Port can operate the door like a garage door, leaving it open partially.

Red / Secure Mode

A security mode designed for use with iLock units. Outside sensors are disabled, open-assist is disabled, and the door is locked.

Orange / Pet Mode

Primary mode for pet use. Pet and Inside sensors are enabled. Outside sensors can be disabled. Pet distance enabled. Door is locked.

These are indicated by the four mode icons on the front of the control panel:



The desired mode is selected by successive presses of the Mode button (to the right of the mode icons). The modes will cycle in the order displayed, though Pet Mode will be skipped if not programmed.

There are four sensor ports located on the right side of the control panel:

Inside Sensor (top port):

A master channel enabled in Green, Red, and Pet Mode. Opens to the programmed full width.

Outside Sensor (2nd port down):

A secondary channel enabled in Green and Pet (if desired) Mode. Opens to programmed full width.

Pet Sensor (3rd port down):

A special channel enabled in Pet Mode only. Opens to the programmed partial pet width.

Stacker Sensor (bottom port):

A specialized channel enabled in Blue Mode only. Can be used to keep the door open partially if desired.

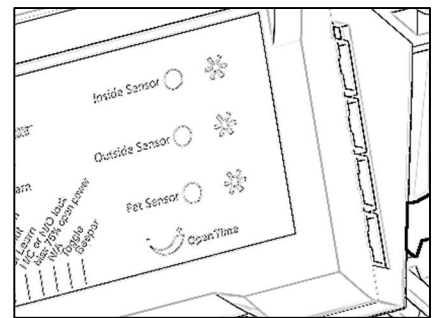

The Open Time dial is located at the bottom of the control panel and keeps the door open between 0-24 seconds before closing. If the dial is turned to the max, the system enters into Toggle Mode. The door then operates per activation of sensor, push to open and push to close. This can be used in Green and Red Modes.

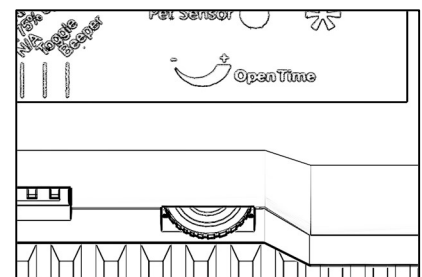

05

OPERATE

SETUP AND OPERATION GUIDE

DIP SWITCH SETTINGS GUIDE

Eight white DIP switches are located at the bottom of the control panel:

<p>1 Direction/Learn</p> <ul style="list-style-type: none"> • Leave in OFF position for right-handed door operation. Leave in ON position for left-handed door operation. • Toggling this back & forth in Blue Mode will program the stacker opening width. • Toggling this back & forth in green or red mode programs the human opening width. 	<p>2 Slam Shut</p> <ul style="list-style-type: none"> • Boosts power at the start of the opening and end of the closing of the door when in ON position. • Designed for tight jambs and weatherseals. • Can't be used when DIP #7 is ON.
<p>3 Pet Learn</p> <ul style="list-style-type: none"> • This switch is used to program the pet width of the AutoSlide. • Toggle ON and OFF to start and stop the door at the desired pet open width. • The direction (left-opening vs right-opening) is already determined from DIP #1. 	<p>4 Secure Pet</p> <ul style="list-style-type: none"> • This switch is used to disable the Outside Sensor channel in Pet Mode. • Designed for security-based pet setups with iLock units.
<p>5 75% Power</p> <ul style="list-style-type: none"> • Reduces the power of the motor if the unit opens too fast or if the door is too light in weight. • Usually turned ON when automating lightweight screen doors or pocket doors. 	<p>6 App Control</p> <ul style="list-style-type: none"> • When turned OFF, enables manual motherboard control of the system. • When turned ON, enables Bluetooth Module (app) control of the system. • This should only be on if a Bluetooth module is plugged in and installed.
<p>7 Extra Power</p> <ul style="list-style-type: none"> • Increases the amount of power the motor uses for heavier sliding doors. • Turn ON if motor is struggling to open/close door. • This cannot be used when DIP #2 is ON. 	<p>8 Beep</p> <ul style="list-style-type: none"> • When turned ON, the AutoSlide will emit an audible beep when the door opens, starts to close, and when it changes modes.

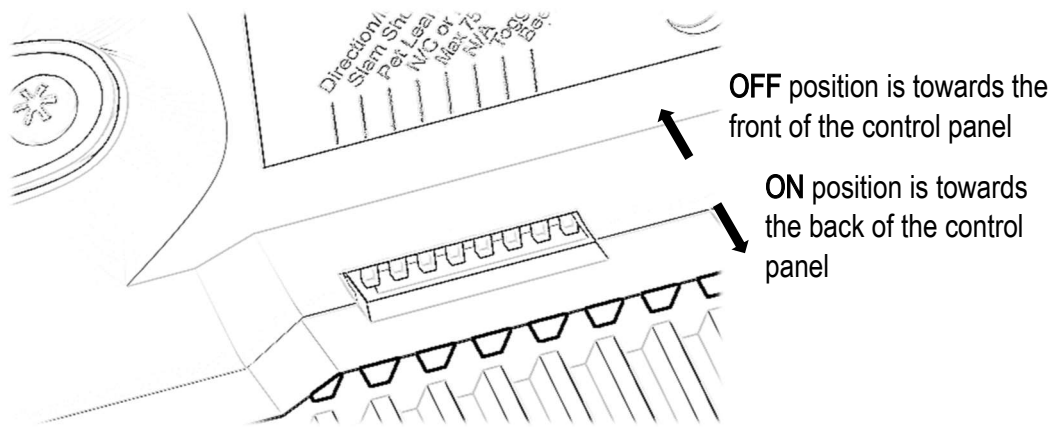

POWERING ON AND INITIALIZING

- 1) Ensure the red power switch on the side of the control panel is set to OFF (O down).

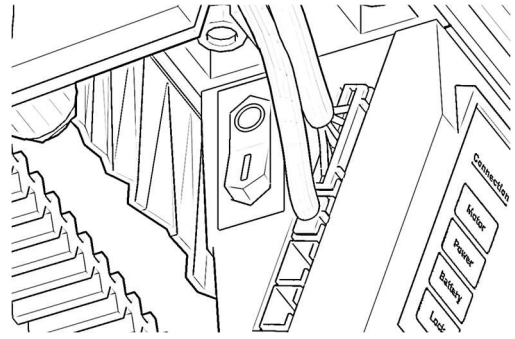

Configure DIP switch settings as desired. Ensure DIP switch #1 is flipped OFF (towards the front of the unit's control panel).

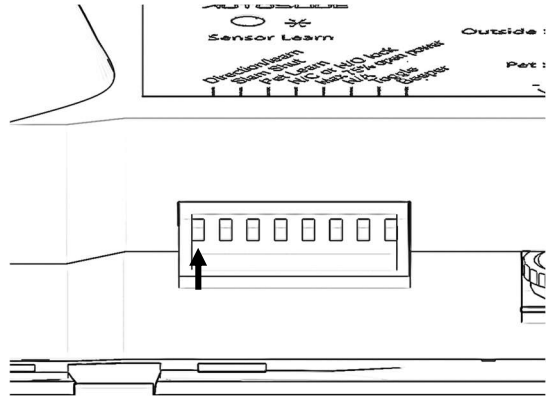

Plug the included power pack into the AutoSlide system's power port (located on the unit's left endcap). Plug the other end into the closest available wall outlet.

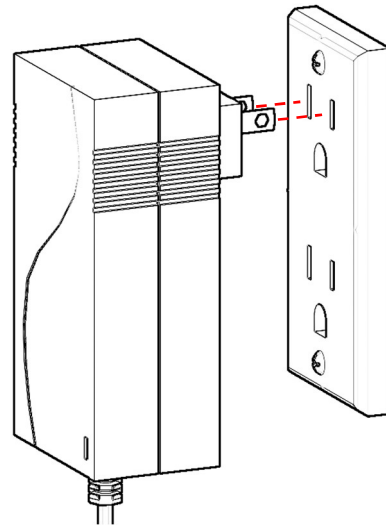
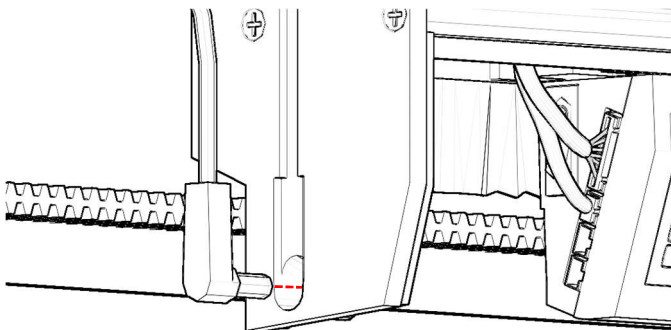

POWERING ON AND INITIALIZING

2)

Manually move the door to halfway between open and closed. Use the red power switch to power the unit on:

- If the unit starts to **close** the door, let the door close completely before proceeding to the next step.
- If the unit starts to **open** the door, power off the unit. Turn DIP switch #1 ON, then power on the unit (see right figure). The door should now start to close.

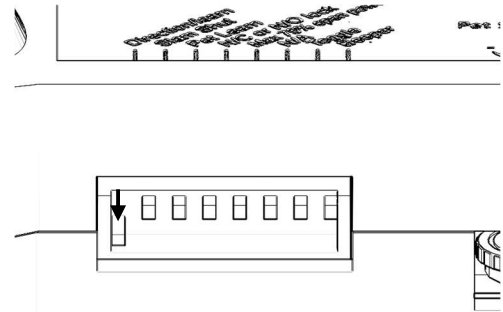
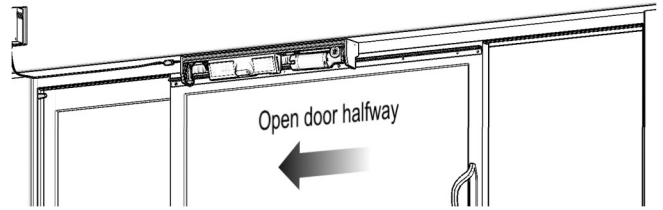

The door should close until it hits a jamb or doorstop. Once it closes and stays closed...

- If the unit has a solid Green mode light on the front, proceed to the next step.
- If the unit has a solid Red, Blue, or Yellow mode light, locate the Mode Button (gray button with a blue star, circled to right). Press this button repeatedly to toggle through modes until the Green Mode light is selected.

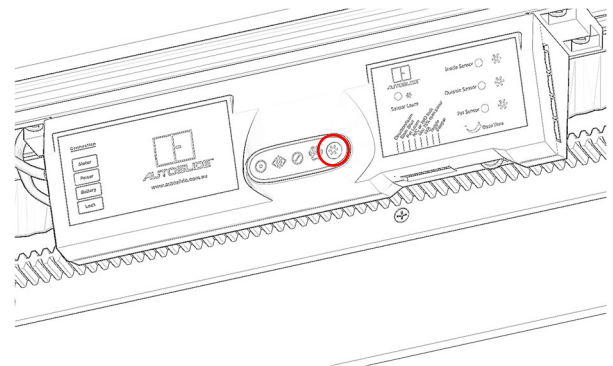
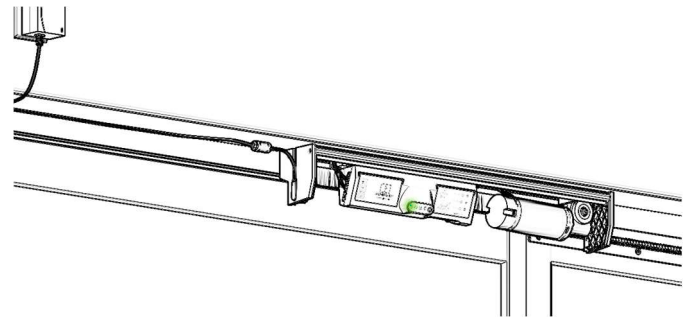

PROGRAMMING FULL OPENING WIDTH

- 3) Ensure an open jamb/doorstopper is in place in the desired max opening position, so the door doesn't run off the AutoSlide track.

To start the programming process, reverse DIP switch #1 from its current position, then **immediately** reverse back DIP switch #1 (flip it back and forth).

- The door will immediately open until it hits an open jamb or doorstop. **If none exist, manually brace the door when it reaches the desired opening width to keep it from opening any further.**

Once the programming process has started, the door will:

1. Slow open fully
2. Slow close fully
3. Fast open partially
4. Slow close fully

Once the door remains in the fully closed position with a solid Green Mode light, the full opening width is programmed.

To test the door, press the button for Inside Sensor located at the top right of the control panel. The door should open and close automatically (if the Open Time dial isn't set at the max position).

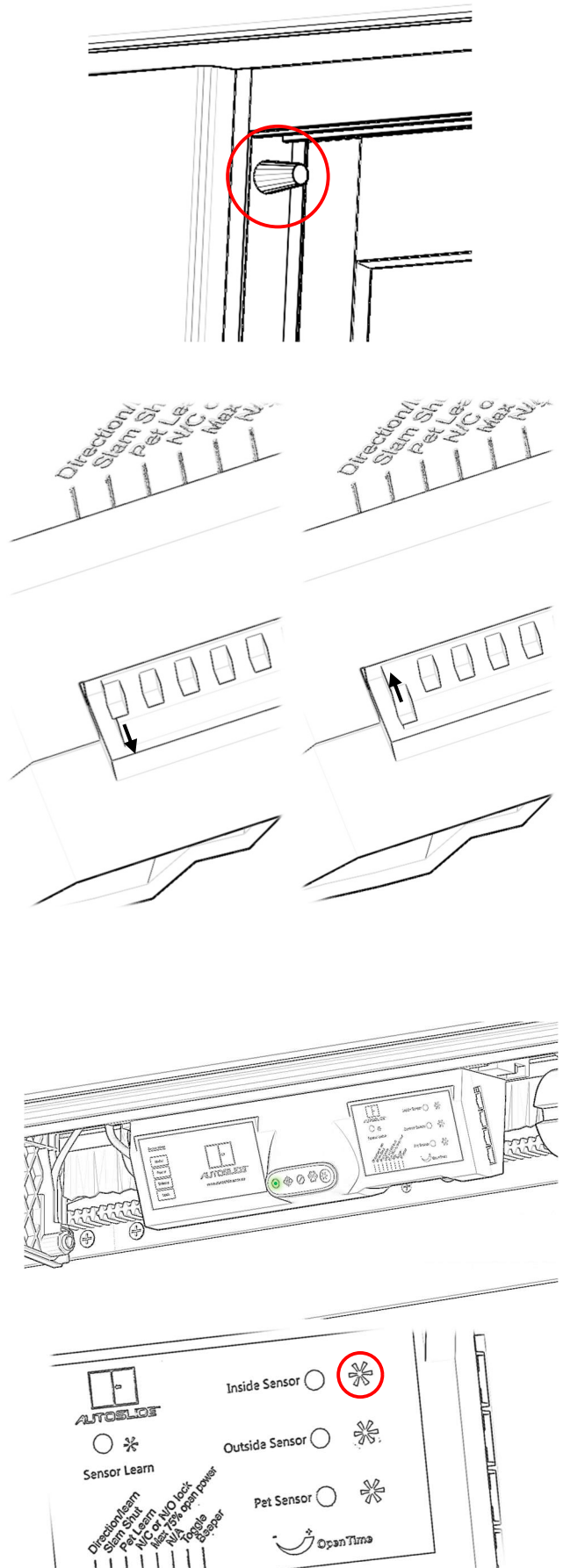

PROGRAMMING STACKER OPENING WIDTH

- 4) From Green Mode, press the mode button (circled at right) one time to place the unit into Blue (Stacker) Mode. The door may open automatically to a partial factory width.

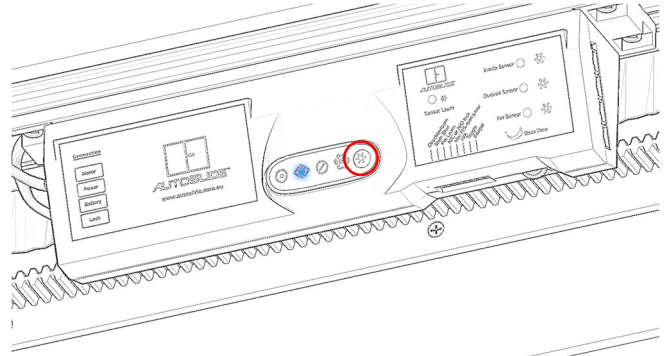

To start the programming process, reverse DIP switch #1 from its current position then **immediately** reverse back DIP switch #1 (flip it back and forth).

- The door will immediately open until it hits an open jamb or doorstop. If none exist, manually pull the door when it reaches the desired full opening width to keep it from opening any further.

Once the stacker programming process is started, the door will:

1. open fully, then
2. close fully.

Once the door is staying in the fully closed position with a solid Blue mode light, the stacker opening width is programmed.

To test the door, press the Mode button repeatedly until the unit is in Green Mode. Once the door is in Green Mode and staying closed, press the Mode button one time to place the door into Blue Mode. The door should automatically open to the programmed Stacker width.

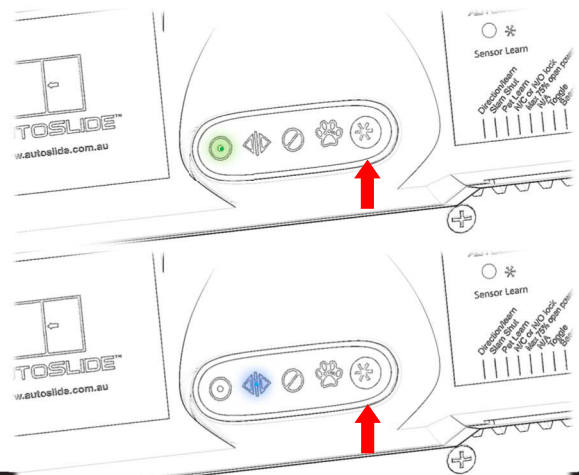
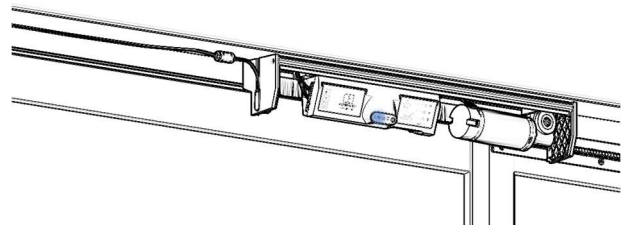
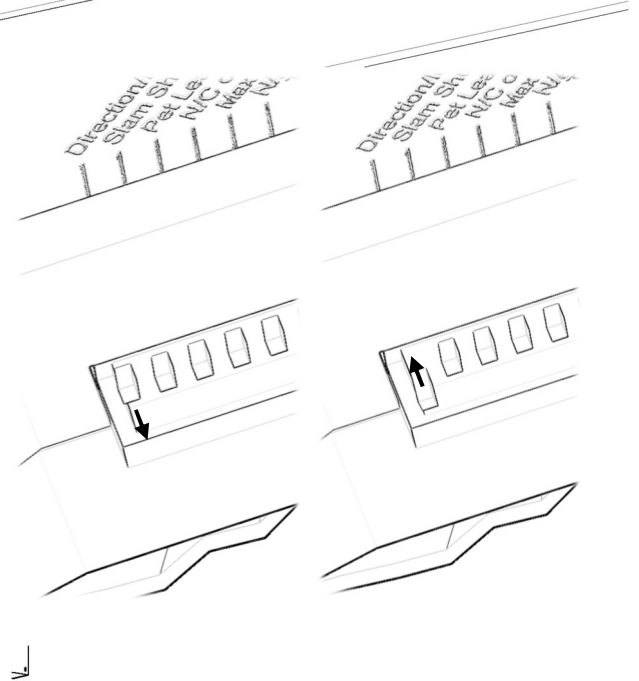

PROGRAMMING PET OPENING WIDTH (FOR PET APPLICATION ONLY)

5)

To start the pet programming process, flip DIP switch #3 ON and back OFF.

- The door will immediately open until it hits a doorstop. Manually brace the door when it reaches the desired pet opening width to keep it from opening any further.

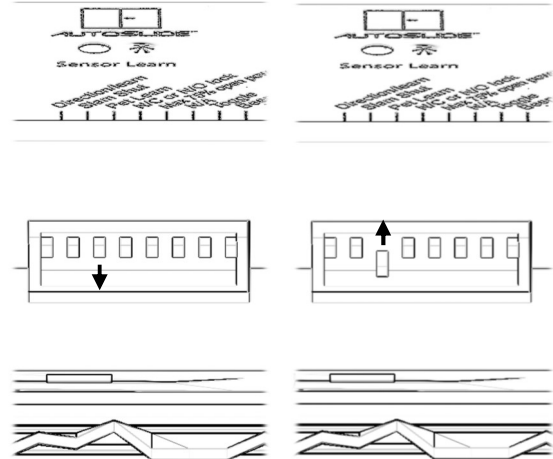

Once the programming process is started, the door will:

1. Slow open fully or until stopped
2. Slow close fully

Once the door remains in the fully closed position with a solid Orange Mode light, the pet opening width is programmed.

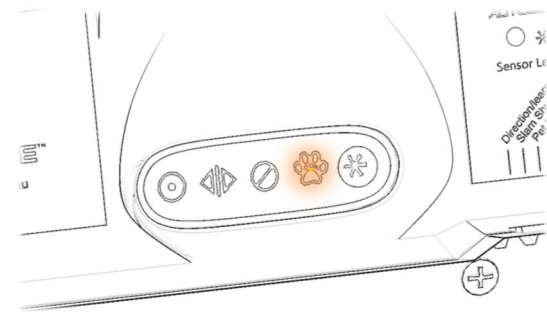

To test the door, press the button for Pet Sensor located on the right of the control panel. The door should open to the partial pet width and close automatically.

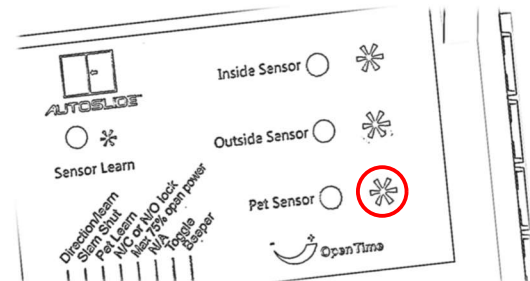

Once the Normal opening width, Stacker opening width, and Pet opening width (if needed) are programmed, the AutoSlide unit setup process is complete.

Note: If power is turned off, the motor (locking or non-locking) will completely disengage for egress and allow manual operation of the door.

Additionally, if power is turned off and back on, all settings are retained. When power resumes, the door will slowly close until it hits the close jamb or doorstop. However, the opening widths will not need to be reprogrammed.

PAIRING WIRELESS WALL BUTTONS AND WIRELESS SENSORS

1. Remove both wireless wall-mounted push buttons from the box and remove the plastic tab battery protector from both buttons.
2. Press each wall button to ensure it flashes blue when pressed. If the door opens when the wall button is pressed, the button is already paired and can be set aside.
3. To pair a button to the AutoSlide, press and release the “Sensor Learn” button on the AutoSlide control panel. A red light should illuminate next to the button once released.
4. Press the wall button once. The red light should blink three times. Press the wall button again. The red light should go out. This indicates the AutoSide has learned the wall button
5. Test the wall button by pressing it to open the door.

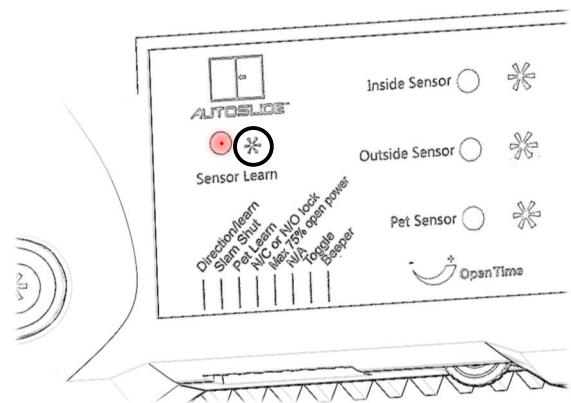
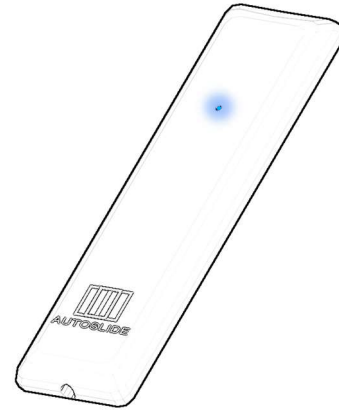

The same process is used to pair any wireless sensor/remote to the AutoSlide system:

1. Press and release the Sensor Learn button once.
 2. Trigger the wireless sensor/remote once.
 3. Trigger the wireless sensor/remote again.
 4. Test the sensor/remote to ensure it's paired to the system.
-

PUTTING THE COVER ON THE SYSTEM

1. Lift the metal unit cover to underneath the system as shown (door and track omitted):

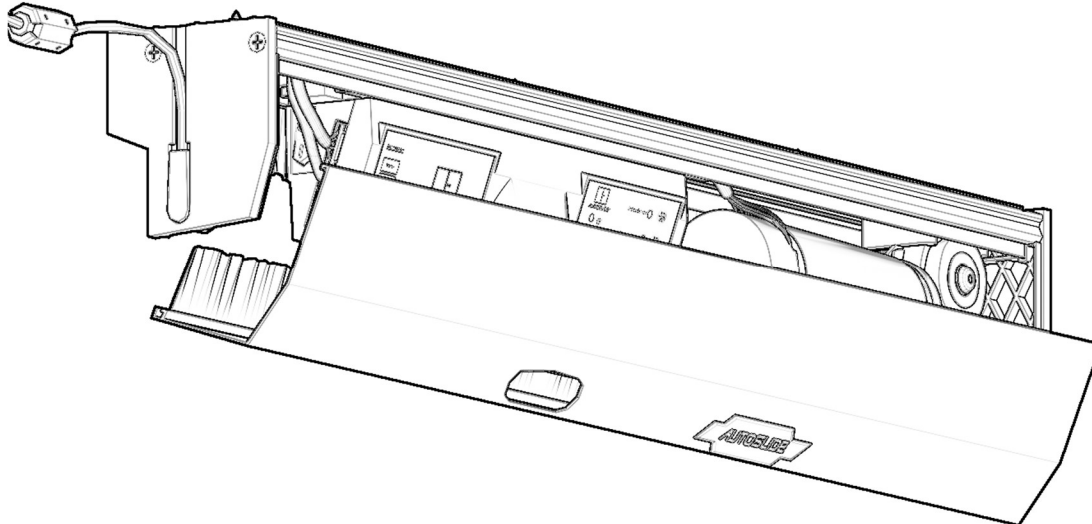

2. Click the tab provided on each of the unit endcaps into the groove in the cover as shown.

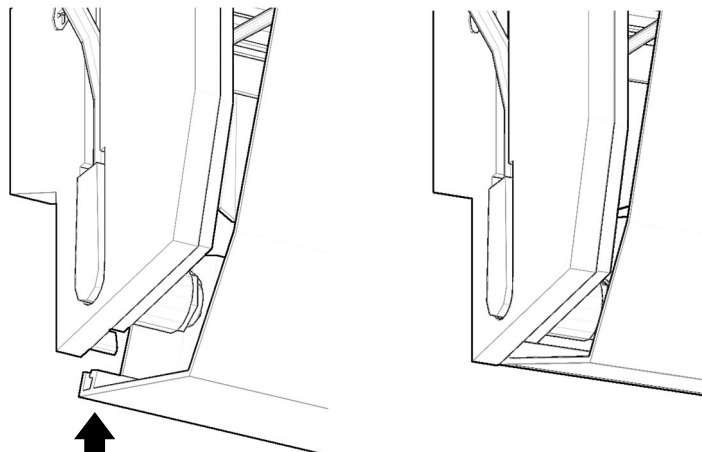

3. Rotate the front of the cover upwards about the groove until it engages with the aluminum base fully and clamps tight.

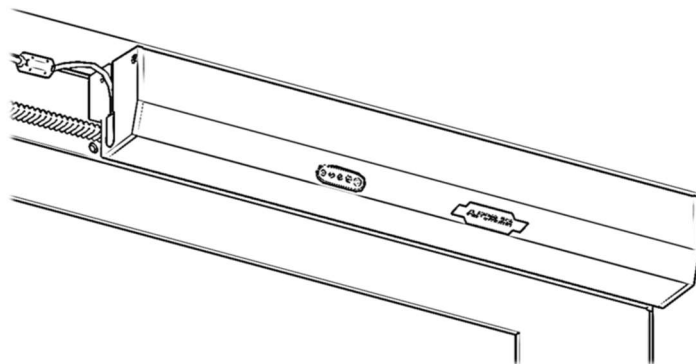
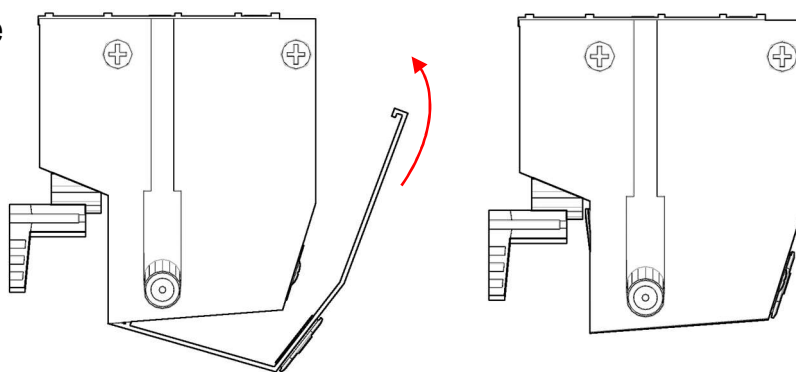

06

FINALIZE

COMPLETING THE INSTALL

FINISHING TOUCHES

CONCEALING THE UNIT

The AutoSlide unit, once mounted, can be concealed under a valence if desired. However, it is advisable to keep an access panel in case the unit or control panel needs to be adjusted. You may need to cut a channel to feed out the power cable and any sensor cables.

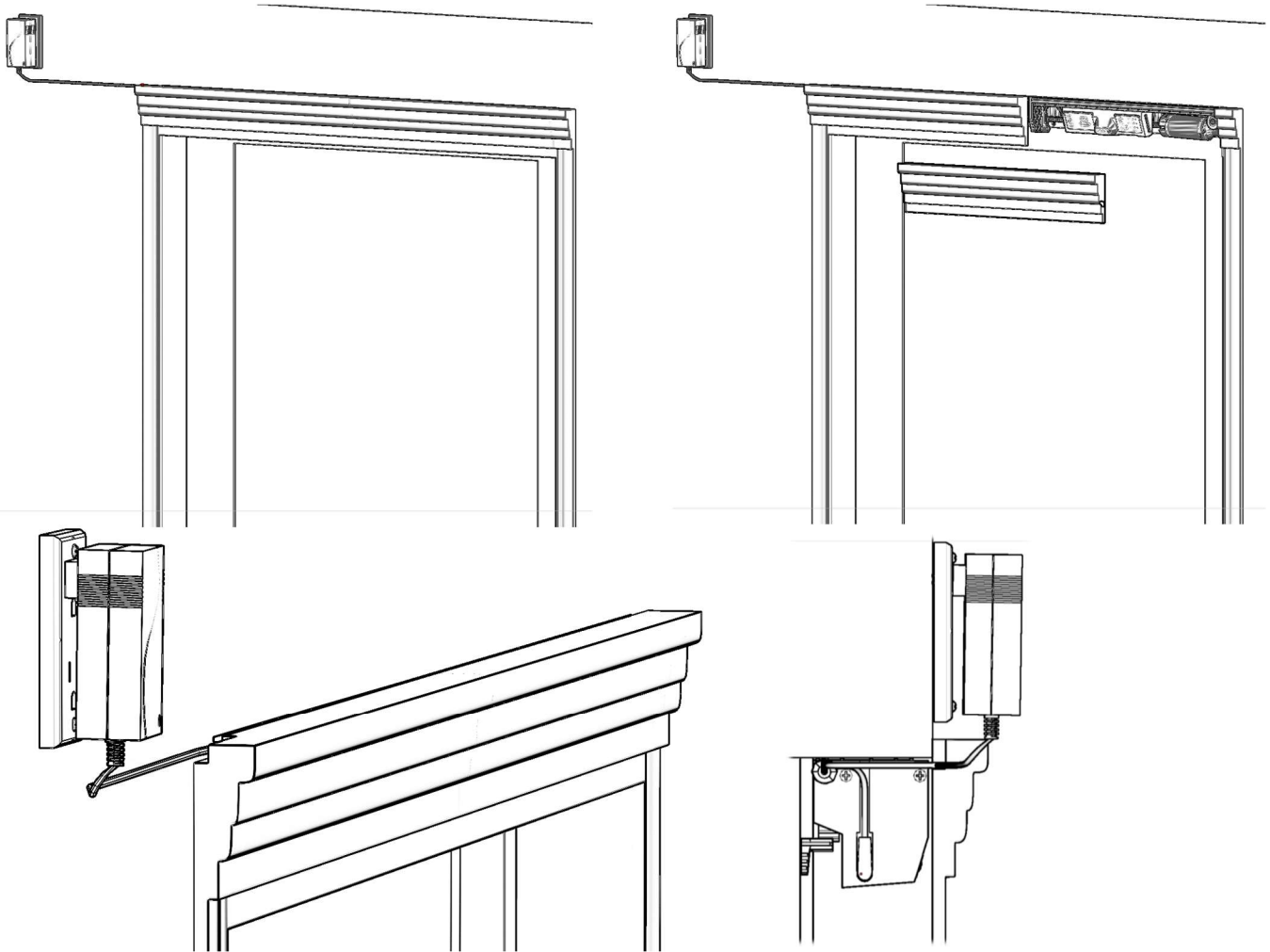

CONCEALING THE CABLES

The power and sensors cables coming out of the Autoslide unit can be concealed using cable covers (not included).

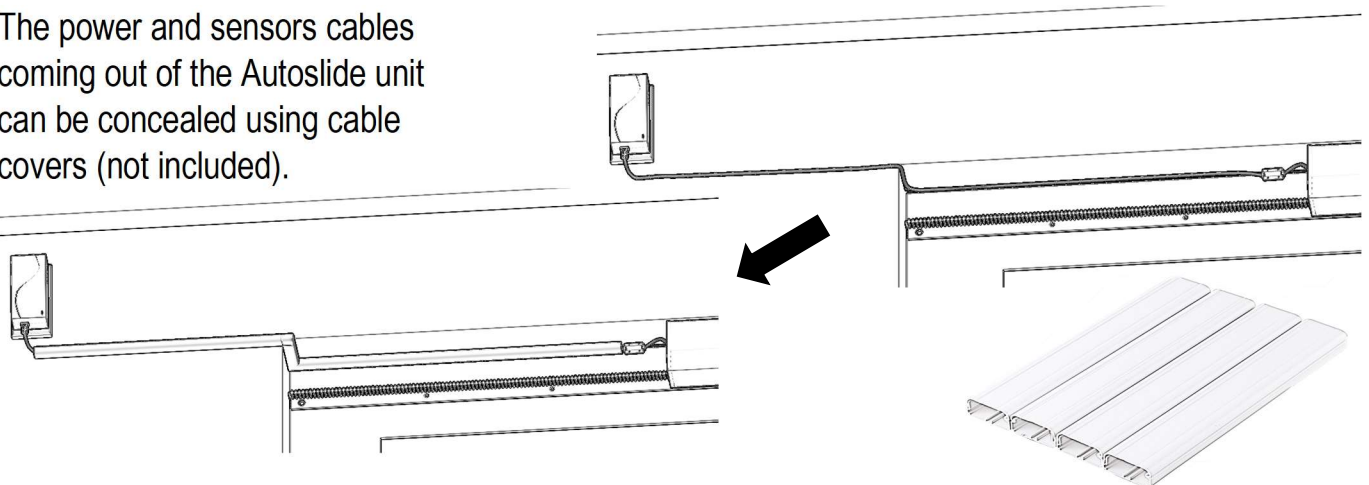

REVERSING THE MOTOR

Re-handing the system (reversing the position of the motor and the control unit) is required if floor mounting onto a left-opening door.

Re-handing should be done prior to starting the installation process. Note that if re-handing the system, the unit's left endcap with the power port may be up against a wall when mounted and inaccessible. Be sure to plug the power cable into the unit endcap's power port before mounting the unit if needed.

- 1) Unplug all cables from the control panel. Unscrew the two screws from the right unit endcap (the endcap without a power port) and remove the endcap.

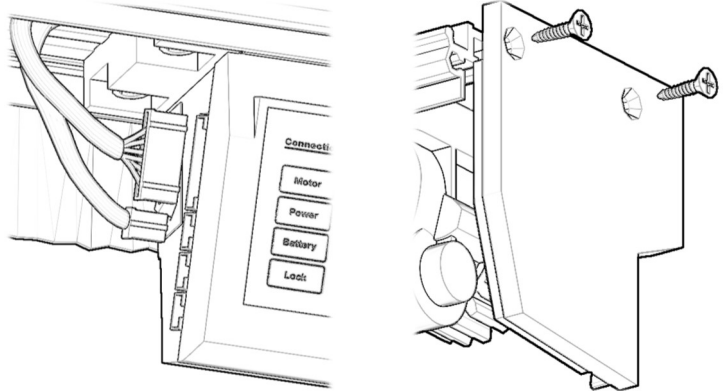

- 2) Use the included Allen key to remove the bolt opposite the motor wheel. Slide out the motor wheel.

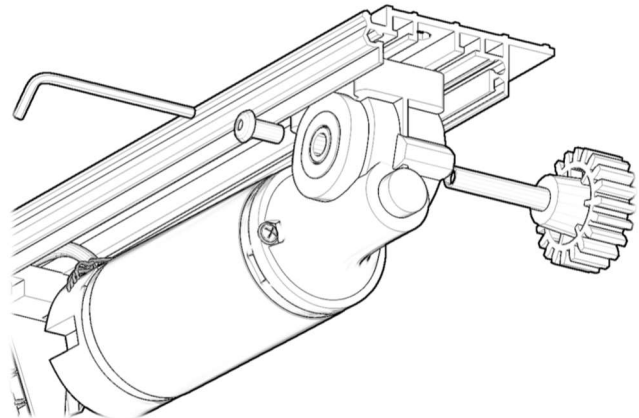

- 3) Insert the motor wheel on the opposite side of the motor and tighten the bolt using Allen key.

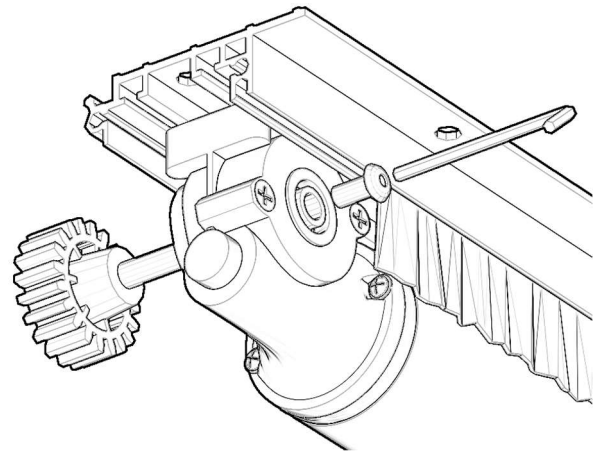

07

REHANDING

REVERSING THE AUTOSLIDE

SWITCHING THE MOTOR AND CONTROL UNIT

- 4) Remove the four screws holding the motor to the unit base. Use the Allen key to remove the four bolts holding the control panel to the unit base.

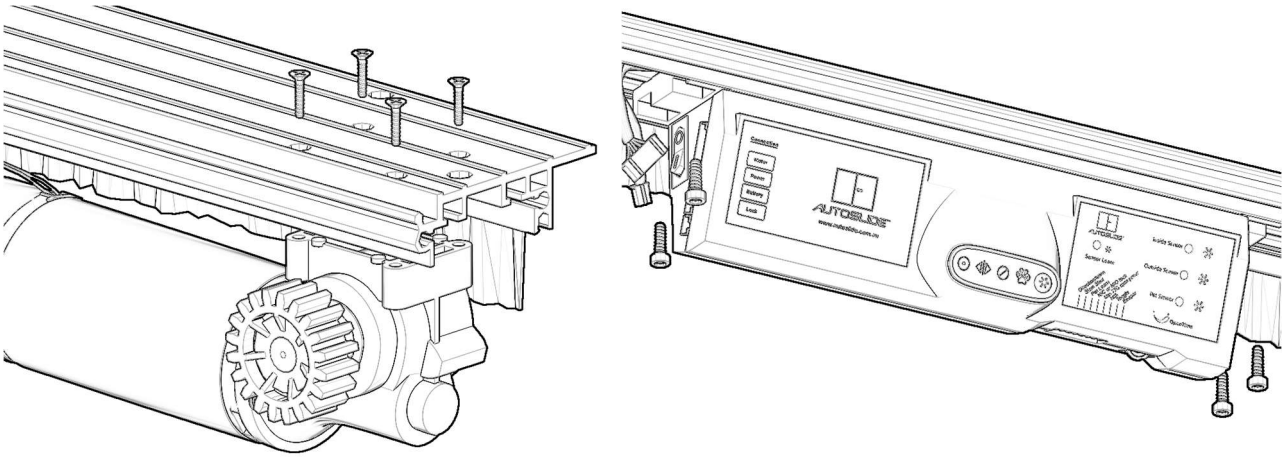

- 5) Slide the base brush and metal bars to the opposite side.

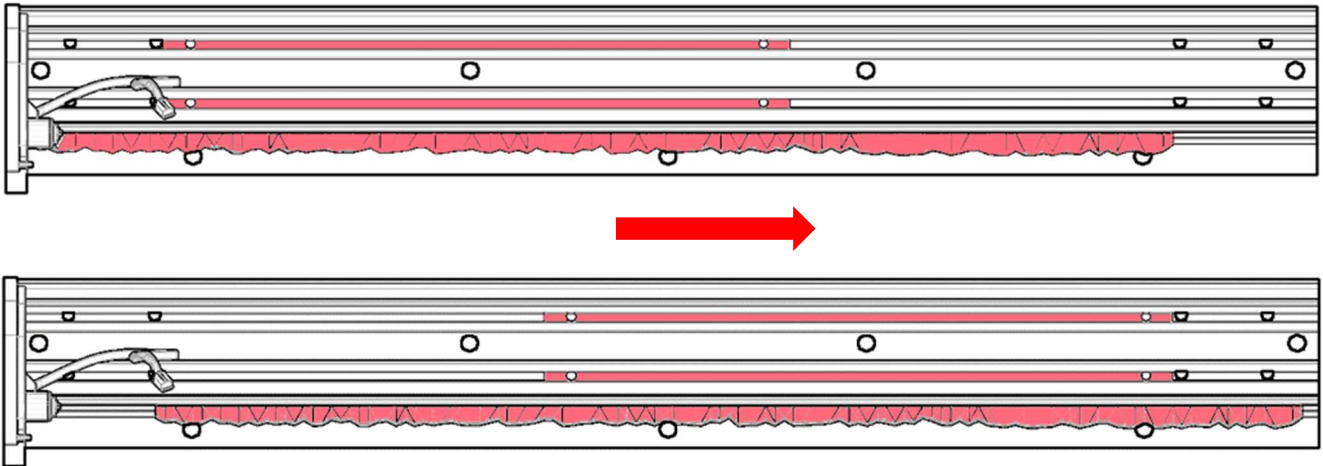

- 6) Place the power cable in extruded recessed area. Unit is shown upside down below.

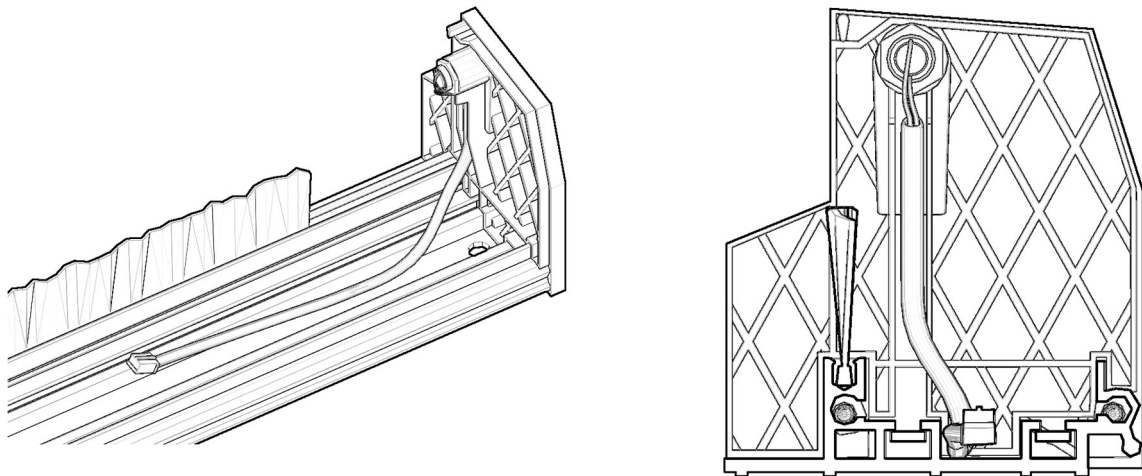

SWITCHING THE MOTOR AND CONTROL UNIT

- 7) Re-attach the motor to the unit base on the opposite side, so it sits above the power cable without damaging it.

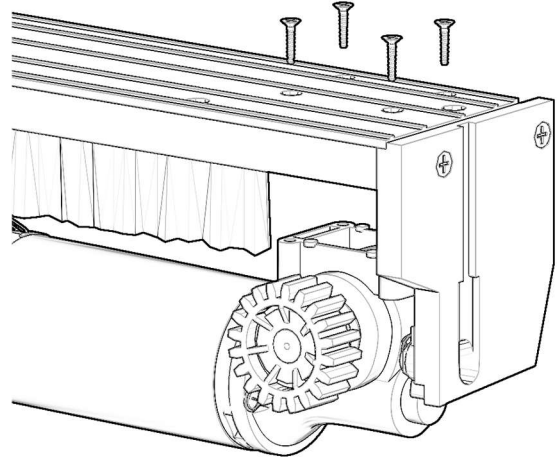
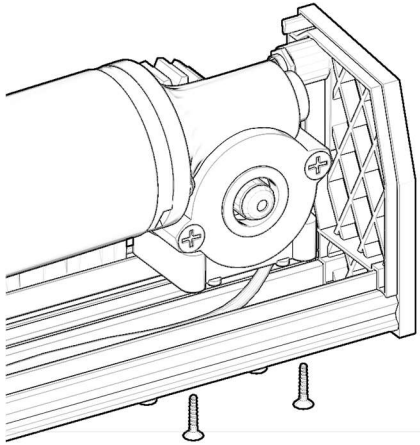

- 8) Reattach the control panel to the metal bars in the unit base using the Allen key. **Do not tighten completely.**

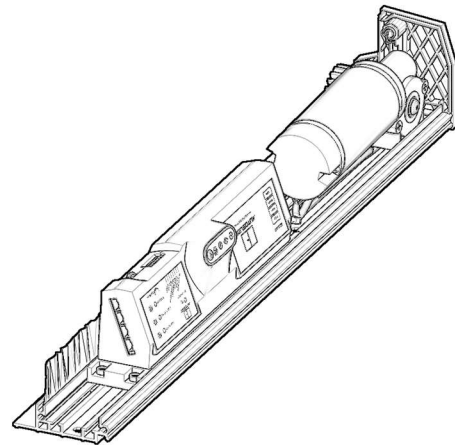
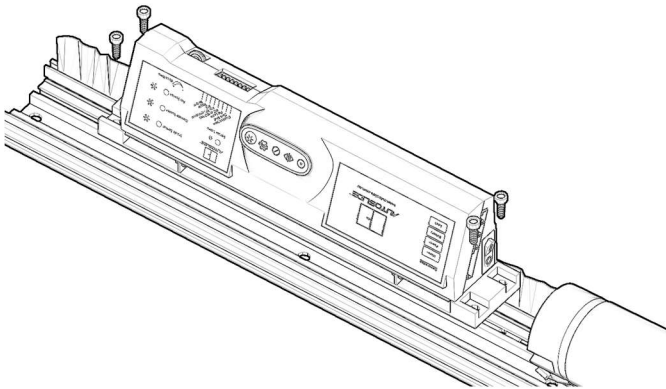

- 9) Re-secure the right endcap to the unit.

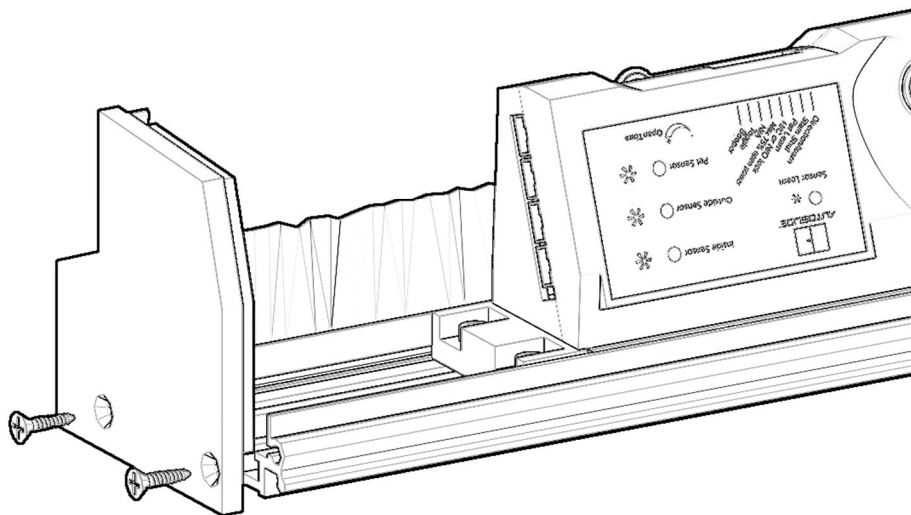

COMPLETING RE-HANDLING

10) Plug the motor and power cables back into their corresponding ports on the control panel.

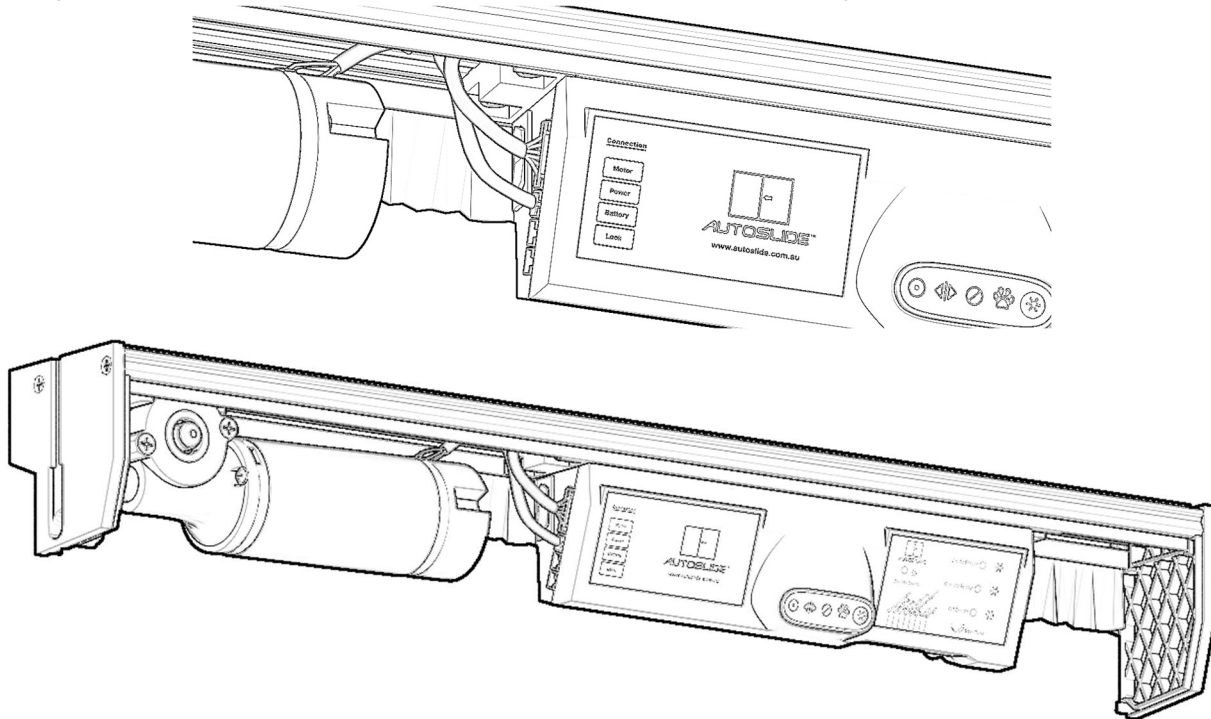

The logo clip on the unit cover can be popped out and put into the opposite cut hole on the cover.

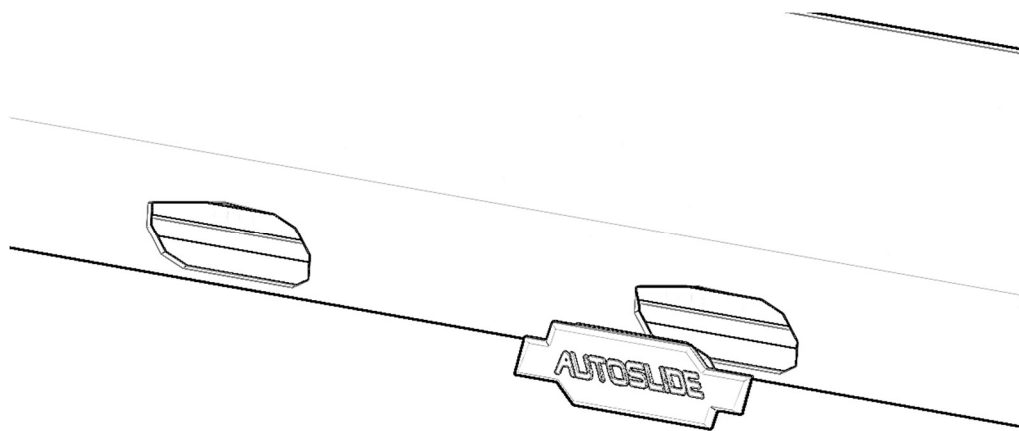

Note: Aligning the mode control pad to the cut in the unit cover may require some slight adjustment to the left or right of the control panel. Once aligned properly, tighten the four Allen key bolts holding the control panel in place. The unit is now re-handled and ready for install.

FREQUENTLY ASKED QUESTIONS

Is there anyone that can install the AutoSlide for me?

While designed to be a Do-It-Yourself project, we have licensed and qualified installers throughout the United States and Canada. Please check our Authorized Dealer Page on our website to find an installer near you. Otherwise, a licensed electrician or local handyman can install the system.

Can I install the AutoSlide outdoors?

The AutoSlide system can be installed outdoors. It is just advised to keep it covered and out of direct rain or snow. If the ambient temperature of the environment goes below 32F, the motor will experience performance issues. It is always advisable to install indoors when possible.

What if there is a power failure?

If power is lost to the system, the motor (and lock if the unit is an iLock system) will completely disengage. The unit will revert back to a manual door to allow for egress. If power is needed during a power failure, ask about our back-up battery.

What if the door hits someone?

Every unit has a built-in Auto-Reverse safety feature. If the door hits an object or person in its closing path, the door will automatically reverse to the opposite direction.

Can I connect this to my home automation system?

Yes, we offer a key switch cable that allows the unit be triggered to open or close by any momentary relay switch. All that is needed is a momentary relay switch compatible with your home automation system. The AutoSlide then can be triggered by your home automation system on command. Feel free to contact us for more details.

Can I control this with my phone?

Yes, we offer a Bluetooth module that allows your AutoSlide system to communicate with our app on your phone or tablet. Paired with the AutoPlus Hub, you can control your AutoSlide from anywhere in the world. Please contact a sales representative for more information.

How can I get a full automatic opening with my barn door or pocket door?

For a full and complete opening with a barn door or pocket door, the motor wheel can be recessed into the wall. An additional option (for pocket doors only) is to extend out the AutoSlide track further past the leading edge of the sliding panel by a few inches. This may require reinforcement (e.g. a wooden block or metal bracket).

09

TROUBLESHOOTING
FAQs AND COMMON ISSUES

COMMON ISSUES

Issue	Cause	Solution
Door only opens partially after width programming.	Incomplete learn cycle.	Remove the unit cover. Power the system off and back on. Once the door is closed, reprogram the opening width by flipping DIP switch #1 back and forth. Ensure the door opens fully during the programming process.
Door emits a loud grinding noise when closed.	Lack of pressure between track and motor wheel.	If your door has height adjustment screws, either raise the sliding door panel to raise the Autoslide tracks tighter to the motor wheel (assuming the unit is top mounted) or slightly shim the unit down to the tracks. Ensure the tracks and unit are not loosely mounted.
Door does opens partially and automatically opens after every close.	Motor wheel is skipping on track and offsetting the unit's calibration.	If your door has height adjustment screws, either raise the sliding door panel to raise the Autoslide tracks tighter to the motor wheel (assuming the unit is top mounted) or slightly shim the unit down to the tracks. Ensure the tracks and unit are not loosely mounted.
Door opens/closes very slowly.	System not configured for door's drag weight.	Turn ON DIP switch #7 to increase the motor's power output.
Door can't overcome starting friction.	Door is either locked or excess friction in door.	Ensure door isn't manually locked. Power off unit and manually open/close door to investigate any excessive friction. Turn ON DIP switch #2 to increase starting power in the motor.
Door labors and excessive noise is produced during operation.	Motor wheel and track may be too tightly meshed.	Ensure there is only a slight gap between the track teeth and the motor wheel along the entire length of track. Adjust as needed. Note that if the motor wheel starts to slip on the track, the motor wheel and track aren't tightly meshed enough.
Door opens at random.	RFID interference or falsely tripping sensor.	Remove the unit cover. Press and release the Sensor Learn button on the control panel (a red light will turn on), then press and hold the Sensor Learn button until the red light turns off. This will clear all wireless sensors. Pair your wireless sensors one by one back to the system to either eliminate interference or find the falsely tripping sensor.

For additional support or questions regarding the system and installation, please contact us directly at support@autoslide.com

WARRANTY POLICY - TWO YEAR LIMITED MANUFACTURER'S WARRANTY

Autoslide Pty Ltd, the only manufacturer of AUTOSLIDE® branded products, warrants their product to the original retail purchaser to be free of material and/or workmanship defects for a period of two years after the date of original retail purchase. Proof of the original purchase and a Return Merchandise Authorization number is required to obtain a remedy under this limited warranty and the product must be returned to an Autoslide service center at your expense. The Autoslide service centers for the USA are located in California and Florida.

During the limited warranty period, Autoslide Pty Ltd or its authorized service representative will repair or replace at Autoslide Pty Ltd's option, without charge, a materially defective product. We may use new or refurbished replacement parts. If we replace the product, it may be with a new or refurbished product of same or similar design. Autoslide Pty Ltd may keep any removed or defective parts, and/or replaced product. The repaired or replaced product is warranted for the remainder of the original warranty or 90 days, whichever is greater. Repair or replacement of this product at Autoslide Pty Ltd's option is your exclusive remedy.

This limited warranty only applies to products purchased, used and serviced in the United States and its territories, or Canada.

This is the only warranty applicable to this product. ALL OTHER WARRANTIES EXPRESS OR IMPLIED INCLUDING ALL IMPLIED WARRANTIES OF MERCHANTABILITY OF FITNESS FOR A PARTICULAR PURPOSE ARE HEREBY DISCLAIMED. AUTOSLIDE PTY LTD IS NOT LIABLE FOR ANY INDIRECT, INCIDENTAL, CONSEQUENTIAL OR SIMILAR DAMAGES INCLUDING, BUT NOT LIMITED TO, LOST PROFITS OR REVENUE, INABILITY TO USE THE PRODUCT, OR ANY OTHER ASSOCIATED EQUIPMENT, THE COST OF SUBSTITUTE EQUIPMENT, AND ANY CLAIMS BY THIRD PARTIES RESULTING FROM THE USE OF THIS PRODUCT.

This warranty gives you specific legal rights, and you may have other rights that vary from state to state. Some states do not allow the exclusion or limitation of incidental or consequential damages, so the limitations or exclusions stated above may not apply.

What Is NOT Covered Under This Limited Warranty:

- Normal wear and tear or cosmetic damage.
- Damage due to accidents, misuse, physical force, improper installation or operation, mishandling, neglect, fire, heat, water, humidity, liquids, insect infestation, or other intrusion.
- Damage caused by use of non AUTOSLIDE accessories or misapplication.
- Products whose serial numbers have been removed, altered or rendered illegible.
- Batteries.
- Products used for business, commercial or institutional purposes.
- Damage caused by acts of nature such as, but not limited to, lightning damage.
- Products returned without valid proof of purchase or proper Return Merchandise Authorisation (RMA) number.

Call our USA office at 833-337-5433 or email us at info@autoslide.com to leave your contact details for a customer service representative. Please leave your name, US state/territory location you are calling from, contact number and email address for a technical support specialist to return your call within 24 hours. Between the hours of 9 am and 5 pm PST, you can chat with one of our live customer service agents online.

10
POLICY

WARRANTY AND RETURN

RETURN POLICY - STANDARD RETURN POLICY OVERVIEW

You may return merchandise purchased from Autoslide for a refund or a replacement, provided that the procedures and requirements are followed. All returns require a return merchandise authorization (RMA) number. An RMA number must be issued within 30 calendar days after the date of purchase. An RMA number is valid for 14 calendar days after it is issued.

Refunds

Products returned with all original parts in original form will not be charged a processing fee. A processing fee of 20 percent will apply to the value of merchandise returned for a refund if original parts are not in their original form. Refunds are applied to the payment method used at the time of purchase 5-10 days after our receipt of the returned merchandise. We will only refund the value of the merchandise returned, not the shipping cost. On items with free shipping returned for a refund, the original shipping cost that we paid the shipping courier will be deducted from your refund.

Exchanges

If you purchased a product that you wish to exchange for an alternate item, you can return the item for a refund and simply place a new order for the item you desire. We do not apply store credit to your new purchase. If we see a new purchase for equal or greater value of your return, we will waive the 20 percent processing fee if it were to apply to your return.

Defective Merchandise

Merchandise that is discovered to be defective upon receipt will be replaced. You may also return defective merchandise for a refund if done so within 30 days of purchase.

Damaged Merchandise

All packages are inspected for damage prior to leaving our warehouse. If your merchandise is damaged during shipment by the shipping courier, please contact us immediately as we must be informed within 10 calendar days from the date of receipt for all damage/shipping related claims. Damaged merchandise can be replaced with the same model only. You may also return damaged merchandise for a refund if done within 10 calendar days of receipt of shipment.

Return Shipping

Return shipping cost (the cost to send merchandise back to our store) is comparable to your cost of driving to any store for returning an item, which is not reimbursable. Therefore, we do not reimburse any return shipping cost.

If an item you received is defective, we will definitely replace the item with a new one. However, we do not cover or reimburse the shipping cost for returning defective merchandise back to our store. We will ship the replacement product to you at our cost and use every good measure to ensure that the replacement order is processed quickly.

If you received Free Shipping on your order, the cost of the original shipping outbound to the shipping address on the order will be deducted from your refund amount.

RETURN POLICY - STANDARD RETURN POLICY OVERVIEW

Replacement Terms

We will send a product replacement for an authorized return following the completion of receiving and inspection at our facility. The replacement will ship within four business days following our receipt of your return (excluding weekends and national holidays). We do not send advance replacements or replacements before we receive and inspect the returned merchandise.

To receive a replacement quicker, you may place a new order for the same item (shipping not included), and we will issue a refund for the full value of the returned product (including shipping), upon completion of our return process.

Returning Items

Please email us at info@autoslide.com Monday-Friday, 9 AM-5 PM Pacific Standard Time to receive an RMA number.

All returned merchandise must be in original condition, and must include the original factory box (UPC bar codes and serial numbers must be intact) and factory packaging (e.g. foam, plastic, wrappings, etc.), peripherals (e.g. tracks, cords, power pack, etc.), and all instruction booklets and paperwork. The RMA number or any other inscriptions must not be written or printed on the product box or packaging. We will not process the return if any of these conditions are not followed.

To locate the nearest shipping outlet, you may contact the following carriers:

UPS: (800) 742-587 or <http://www.ups.com>

FedEx: (800) 463-3339 or <http://www.fedex.com>

USPS (Post Office): (800) 275-8777 or <http://www.usps.com>

Remember, returned merchandise that is lost or damaged during transit is solely the shipper's responsibility (which is you when you return a product to us). It is important to save the tracking information and to properly insure all merchandise being returned to Autoslide LLC..

Return Exceptions

Although our return policy is quite flexible on most items, there are some exceptions, as written below:

- Any product not purchased from www.autoslide.com
- Any product without a valid, readable serial number, including but not limited to products with missing, damaged, altered, or otherwise unreadable serial number
- Any product that is returned without all original packaging and accessories, including the retail box, manuals, cables, and all other items originally included with the product
- Any product from which the UPC code has been removed from its packaging
- Any product that exhibits physical damage or abuse
- Products that are not eligible for return for any of the above reason(s) will be sent back to you at your cost and expense.