

⚠ WARNINGS

THIS PRODUCT CONTAINS SMALL PARTS AND IS NOT SUITABLE FOR CHILDREN UNDER 36 MONTHS. SMALL PARTS ARE A CHOKING HAZARD.
THIS PRODUCT IS INTENDED FOR USE BY CHILDREN AGED 3 YEARS+.
MAXIMUM USER WEIGHT: TP959 100KGS TP960 70KGS
ONLY FOR DOMESTIC USE. FOR OUTDOOR USE ONLY.
TOY MUST BE ASSEMBLED BY AN ADULT BEFORE USE.
CHILDREN MUST NOT USE THIS PRODUCT UNTIL PROPERLY INSTALLED.
ADULT SUPERVISION REQUIRED.
REMOVE ALL PACKAGING BEFORE GIVING TO YOUR CHILDREN.
RETAIN PACKAGING FOR FUTURE REFERENCE.

TP959 & TP960 Slide Body Assembly



Instructions for assembly, maintenance and safe use.
Please retain for future reference.

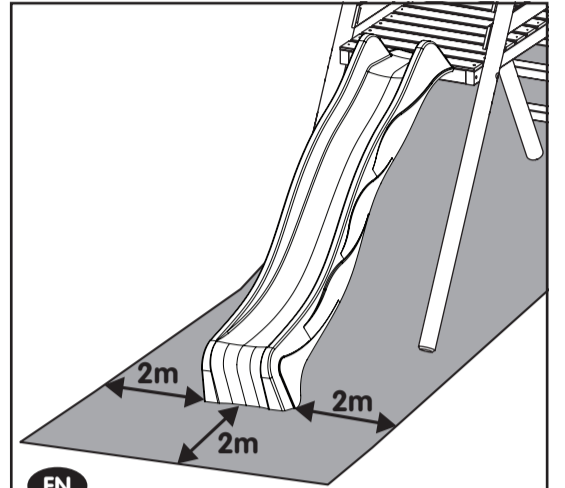
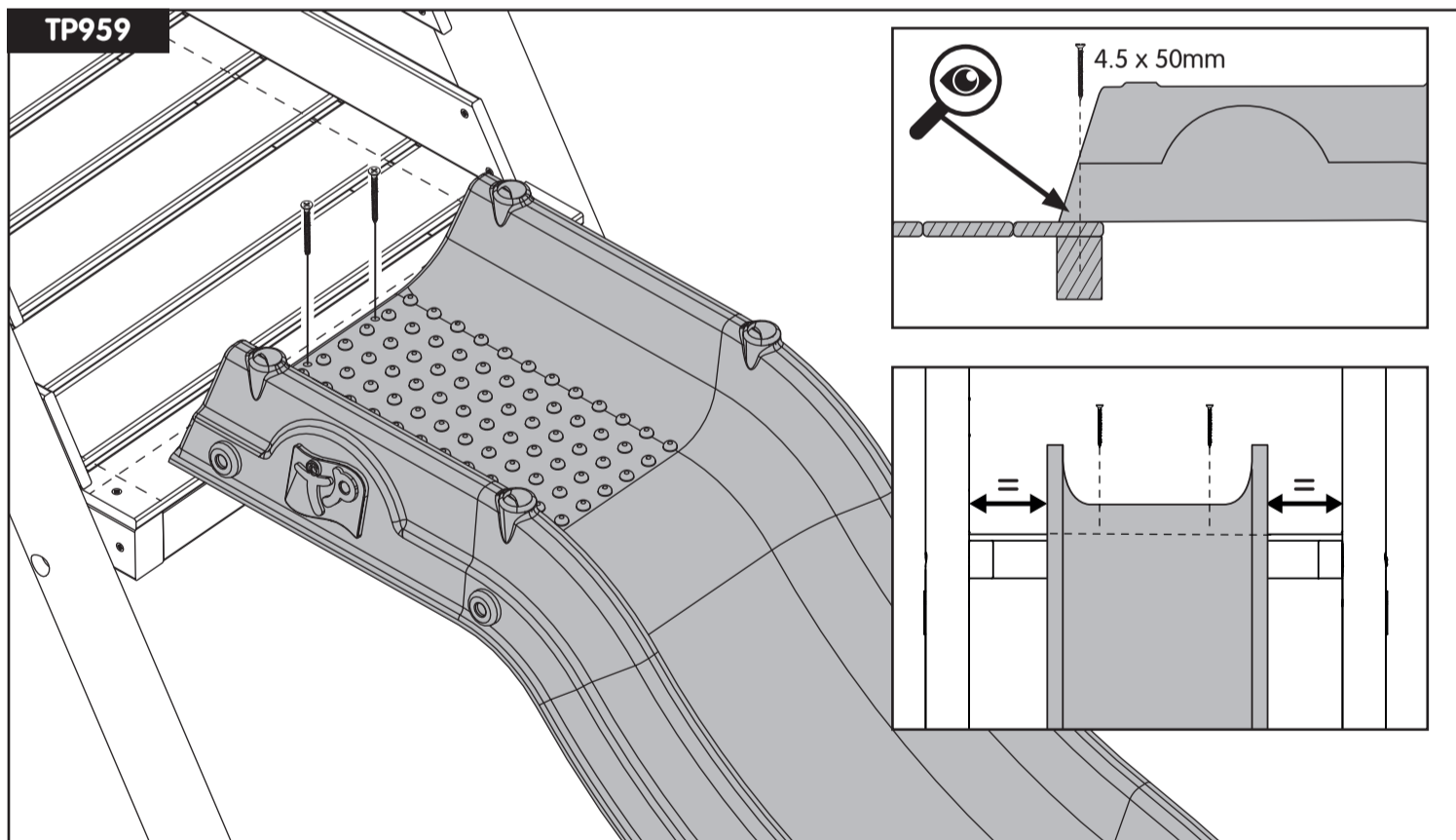
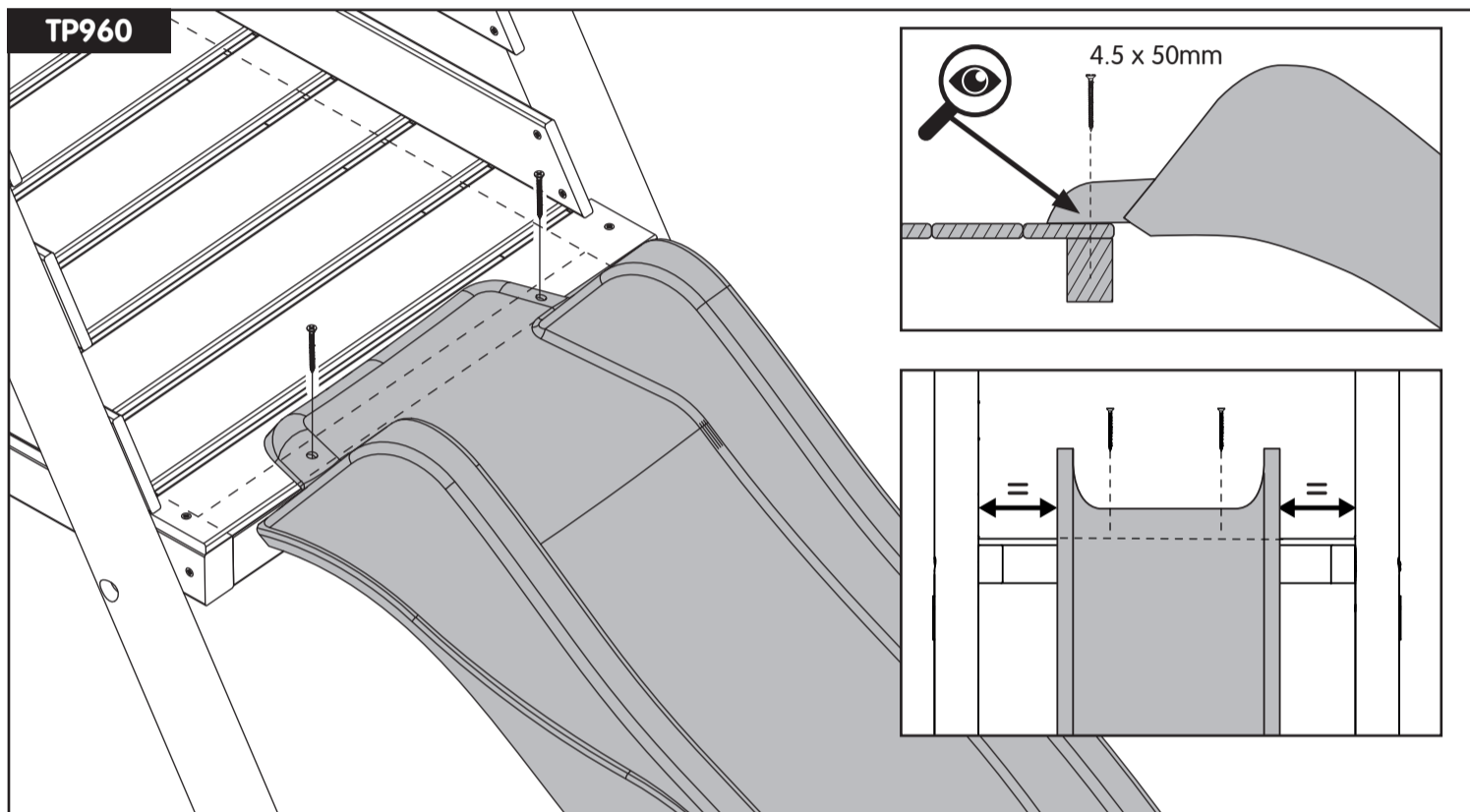
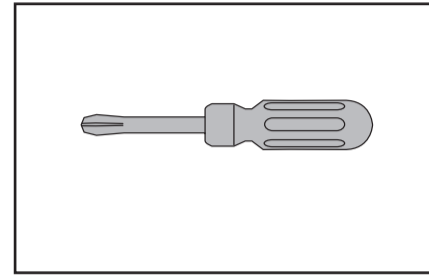
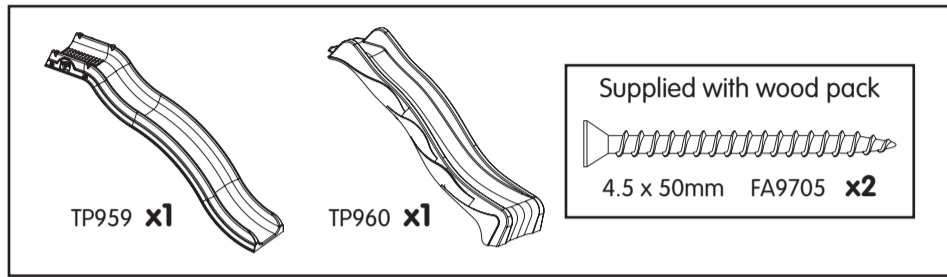

EN

The safe play area refers to the zone extending 200cm around the toys on all sides and 250 cm above the toy.
The safe play area must be free from all obstacles.

FR

L'espace de sécurité se rapporte à la zone de 200 cm qui s'étend de tous les côtés autour des jeux et à la zone de 250 cm qui s'étend au-dessus du jeu. L'espace de sécurité doit être libre.

DE

Der sichere Spielbereich bezieht sich auf eine Zone von 200 cm rund um das Spielzeug sowie 250 cm oberhalb des Spielzeugs. Der sichere Spielbereich muss frei von allen Hindernissen sein.

ES

El término zona segura de juego hace referencia a la zona que abarca un radio de 200 cm en torno al juguete y 250 cm por encima del juguete. La zona segura de juego debe estar despejada y libre de todo obstáculo.

IT

L'area di gioco sicura si riferisce alla zona che si estende per 200 cm su tutti i lati attorno all'insieme da gioco e per 250 cm sopra l'apparato. L'area di gioco sicura deve essere priva di ostacoli.

NL

Het veilige speelgebied betreft de zone die zich 2 meter aan alle zijden rond de speeltoestellen bevindt en 2,5 meter boven het speeltoestel. Het veilige speelgebied moet vrij zijn van enig obstakel.

PT

A área de segurança refere-se à zona que se estende 200 cm para todos os lados para além do brinquedo e 250 cm acima do brinquedo. A área livre não deve conter qualquer obstáculo.

PL

Wolna przestrzeń bezpiecznej zabawy to strefa 200 cm wokół zabawki oraz 250 cm nad zabawką.
W wolnej przestrzeni bezpiecznej zabawy nie powinno być żadnych przeszkód.

AR

تشير منطقة اللعب الآمن إلى المنطقة التي تمتد 200 سم حول الألعاب من جميع الجوانب و250 سم فوق الألعاب.
يجب أن تكون منطقة اللعب الآمن خالية من أي عوائق



Thank you

Thank you for purchasing this product.

Please register your new product on line at tptoys.com

www.tptoys.com/productregistration

Find out about the guarantee for this product, visit www.tptoys.com/guarantee

For customer services and help with your product, visit www.tptoys.com/customer/help

Your TP Guarantee Number/Product Batch No is

Designed in the UK by **Robovision Ltd t/as TP Toys**
Unit 11, Enterprise Way, Flitwick, Bedfordshire. MK45 5BX

www.tptoys.com

