



WWW.SMITTYBILT.COM

Installation Instructions

SRC Classic Rear Bumper (#76750)
1987-2006 Jeep Wranglers

NOTE: Carefully read entire instructions thoroughly before attempting to assemble and/or install this product.

Parts Included	Qty
Rear Bumper	1
Backing Plates	4
10mm x 30mm Hex Bolt	8
10mm Flat Washer	8
10mm Lock Washer	8
12mm x 40mm Hex Bolt	2
12mm Flat Washer	2
12mm Lock Washer	2



Step 1: Remove factory bumper, if equipped.

Step 2: Locate (2) Backing Plates, (4) 10mm Hex Bolts, (4) 10mm Flat Washers, and (4) 10mm Lock Washers. With a helpers assistance hold backing plates to the rear of the vehicle frame. Align holes in rear plate on the Bumper to those existing holes in the frame. Loosely attach to one side of vehicle with the hardware listed in this step.(Fig 1)For ease of installation it is recommended to remove the rear body mount bolts. (Fig 2) Be sure to secure after installation is complete.

Step 3: Repeat Step 2 for opposite side; loosely attach bolts at this time.

Step 4: Align the lower mount brackets (one per side) with the holes on the bottom of the frame. Using (1) 12mm Hex Bolt, (1) 12mm Flat Washer, and (1) 12mm Lock Washer attach and secure the bottom bracket to the frame. **Note:** if equipped, the factory bolt can be used in this step.

Step 5: Repeat Step 4 for opposite side.

Step 6: Tighten all hardware completely at this time. Installation is now complete.

Note: On TJ models the inner holes will need to be drilled. These are optional and will require dropping the fuel tank for installation of the inner metal Plates. Measure the distance on the mounting bracket and match these measurements on the frame or you may mount the outer four holes to the frame and use the holes on the bracket as a template to mark the drilling locations. Remove Bumper and set aside. Drill the frame holes to 7/16". (Fig C) **CAUTION: Use extreme care in assuring the locations you drill are correct. Before drilling be sure to check the backside of the frame for possible hazards or obstructions**

For Technical Support/Warranty Information please call 310-762-9944

Smittybilt, 400 West Artesia Blvd. Compton, CA 90220



WWW.SMITTYBILT.COM

Installation Instructions

SRC Classic Rear Bumper (#76750)

1987-2006 Jeep Wranglers

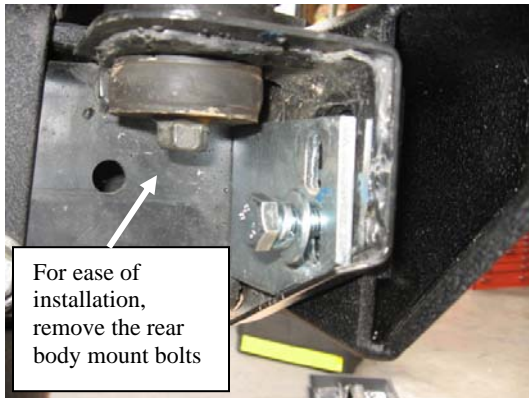
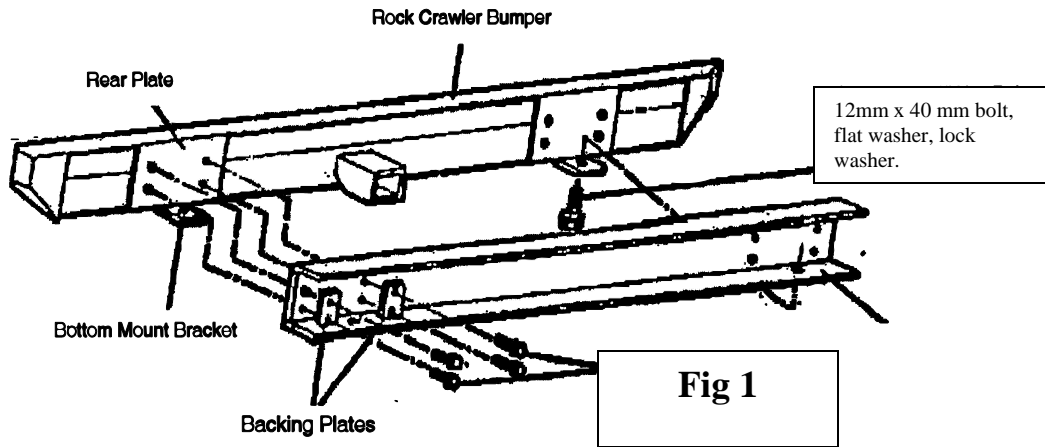

(Fig B)

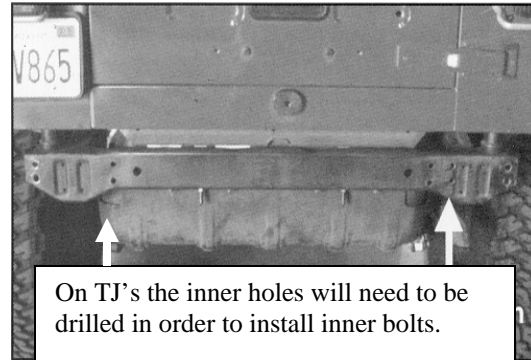

(Fig C)

NOTE: The receiver hitch on this part is not rated for towing but is accessory friendly.

Product cleaning and maintenance instructions

Dual state powder coat finish – Mild soap, window or glass cleaner may be used to clean the finish. In order to protect the finish, you may wax your product on a regular basis with pure carnauba automotive wax. Do not use any types of soap, polish or was that contains abrasive that could damage the finish

WARRANTY

Smittybilt's products are covered under the following limited warranties only. Note that the duration of the limited warranty differs according to the material and finish of the product purchased. Subject to the duration and conditions of the limited warranty stated below, Smittybilt warrants to the original retail purchaser that its products are free from defects in material and workmanship. All other warranties and representations express or implied are hereby disclaimed, including fitness for merchantability and buyer's intended use or purpose. All parts are sold "AS IS" except for the limited warranties granted herein. Buyer assumes all risks as to the selection, suitability and performance of all goods and products selected. This limited warranty does not cover damage or impairment in any part due to misuse, improper installation, accident or contact with on-road or off-road hazards, product modification, improper or inadequate cleaning and/or maintenance. Smittybilt is not responsible for items damaged during shipping. This warranty is not transferable from the original buyer. For the original Buyer to be eligible for the limited warranty coverage, the Buyer must provide proof of purchase. Smittybilt strongly recommends returning the warranty registration card.

Customer's remedy hereunder shall be limited only to repair or replacement (at Smittybilt's option) of any defective part(s) returned to Smittybilt at customer's expense. The determination of whether or not a returned part is defective or subject to coverage under the limited warranties stated herein shall be made at Smittybilt's sole discretion. **Limited Five (5) Year / 50,000 Mile Pro-Rata Warranty (whichever occurs first) on Dual-Stage Powder Coating Products** - Smittybilt dual-stage powder coated products carry the foregoing limited repair or replacement warranty for a period of (5) years or 50,000 miles (whichever occurs first) from date of purchase **against workmanship and defects in the material**, provided that any claim submitted after (2.5) years from date of purchase shall, if accepted, be satisfied by Smittybilt offering customer a credit on the purchase of a replacement product equal to fifty percent (50%) of customer's initial purchase price.

For Technical Support/Warranty Information please call 310-762-9944

Smittybilt, 400 West Artesia Blvd. Compton, CA 90220



WWW.SMITYBILT.COM

Installation Instructions
SRC Classic Rear Bumper (#76750)
1987-2006 Jeep Wranglers

For Technical Support/Warranty Information please call 310-762-9944

Smittybilt, 400 West Artesia Blvd. Compton, CA 90220



WWW.SMITYBILT.COM

Installation Instructions
SRC Classic Rear Bumper (#76750)
1987-2006 Jeep Wranglers

For Technical Support/Warranty Information please call 310-762-9944

Smittybilt, 400 West Artesia Blvd. Compton, CA 90220



WWW.SMITYBILT.COM

Installation Instructions
SRC Classic Rear Bumper (#76750)
1987-2006 Jeep Wranglers

For Technical Support/Warranty Information please call 310-762-9944

Smittybilt, 400 West Artesia Blvd. Compton, CA 90220