



Installation Instructions

HighRock 4x4™ Overhead Rack

Vehicle Application

- Jeep Wrangler Unlimited Soft Top Only
2007 and newer
Part Number: 41415

www.Bestop.com - We're here to help! Visit our web site and click on ["Ask a Question"](#). Click here for more [Jeep Accessories by Bestop](#).

INSTALLATION TIME	SKILL LEVEL		
 1 Hour	 1 - Easy		
TOOLS			
 Tape Measure	 Ratchet	 Socket 7/16"	 Pen
 Allen Wrench 5/32"	 Utility Knife	 Wire Cutters	 Wrench 7/16"
 Safety Glasses			



CAUTION

Safety glasses should be worn at all times while installing this product.

WARNING

This product is designed primarily to enhance the appearance of the vehicle and to shield the occupants from ordinary weather conditions. Do not rely in any way on the components of this product to contain occupants within the vehicle, or to protect against injury or death in the event of an accident. This product will not protect the occupants from falling objects. Never operate the vehicle in excess of manufacturer's specifications.

WEAR SEAT BELTS AT ALL TIMES

Read and follow, precisely, all installation instructions provided when installing product. Failure to do so may result in a poor fit and could place occupants of the vehicle in a potentially dangerous situation.

HighRock 4x4™ Overhead Rack – Installation Instructions

Parts List and Hardware Identification

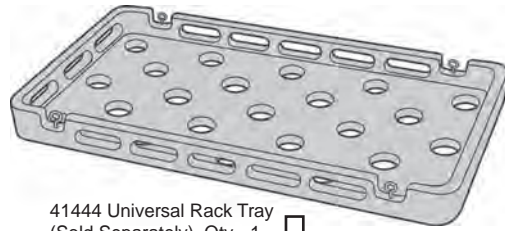

41444 Universal Rack Tray
(Sold Separately), Qty - 1

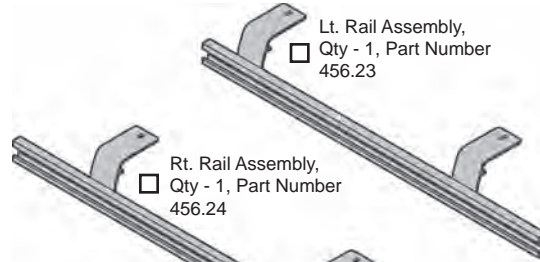

Lt. Rail Assembly,
Qty - 1, Part Number
456.23

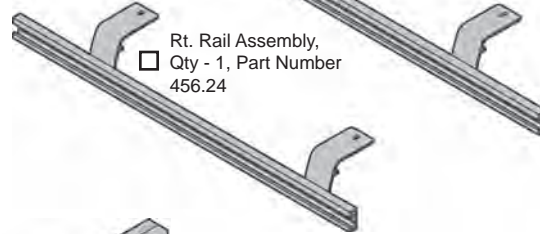

Rt. Rail Assembly,
Qty - 1, Part Number
456.24

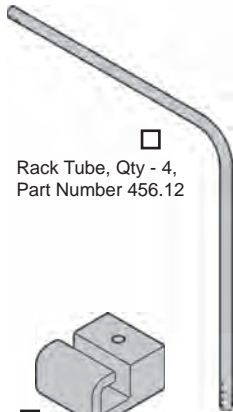

Rack Tube, Qty - 4,
Part Number 456.12

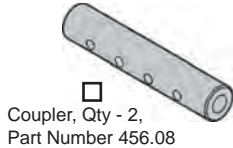

Coupler, Qty - 2,
Part Number 456.08

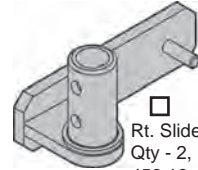

Rt. Slide Assembly,
Qty - 2, Part Number
456.16

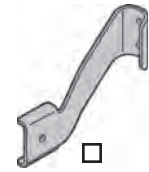

Lt. Gusset, Qty - 2,
Part Number 456.27

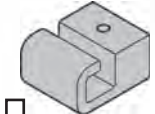

Clamp, Qty - 4,
Part Number 456.04

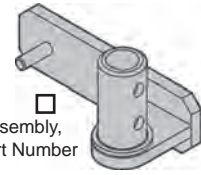

Lt. Slide Assembly,
Qty - 2, Part Number
456.15

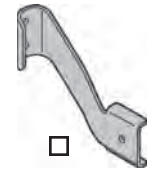

Rt. Gusset, Qty - 2,
Part Number 456.28



Tube Clamp, Qty - 4,
Part Number 472.36

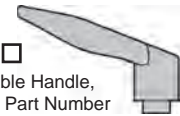

Adjustable Handle,
Qty - 4, Part Number
456.29



Foam, Qty - 2, Part
Number 459.14

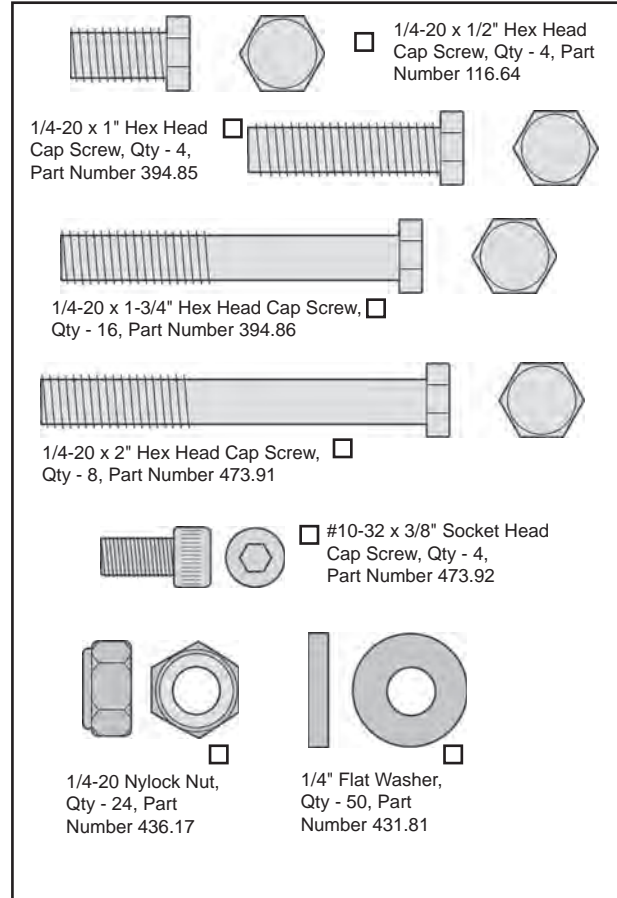

1/4-20 x 1/2" Hex Head
Cap Screw, Qty - 4, Part
Number 116.64

1/4-20 x 1" Hex Head
Cap Screw, Qty - 4,
Part Number 394.85

1/4-20 x 1-3/4" Hex Head Cap Screw, Qty - 16, Part Number 394.86

1/4-20 x 2" Hex Head Cap Screw, Qty - 8, Part Number 473.91

#10-32 x 3/8" Socket Head
Cap Screw, Qty - 4,
Part Number 473.92

1/4-20 Nylock Nut,
Qty - 24, Part
Number 436.17

1/4" Flat Washer,
Qty - 50, Part
Number 431.81

HighRock 4x4™ Overhead Rack – Installation Instructions

1 Install Slide Assemblies on Rack Tubes

Place the Left and Right Slide Assemblies into the bottom of the Rack Tubes. Use two (2) 1/4-20 x 1" Hex Head Cap Screws, 1/4" Washers and 1/4-20 Nylock Nuts to secure each Slide Assembly. Create two (2) Left Tube Assemblies and two (2) Right Tube Assemblies.

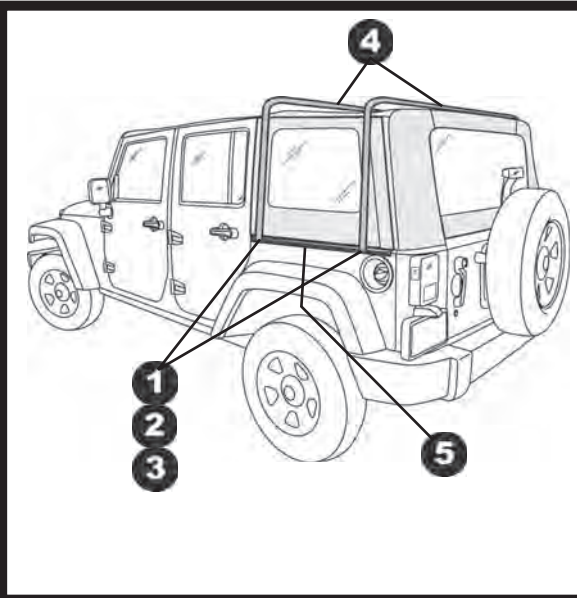
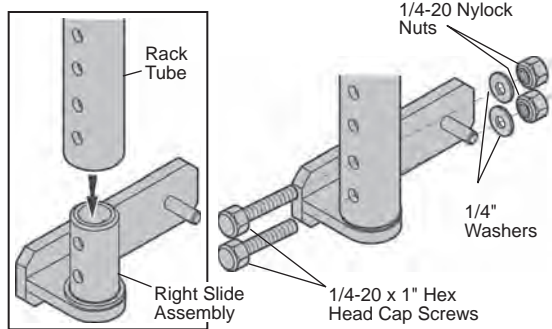

4 Assemble Right and Left Tube Assemblies

Use a Coupler to slide a Right and Left Tube Assembly together. Secure the Coupler with four (4) 1/4-20 x 1" Hex Head Cap Screws, 1/4" Washers and 1/4-20 Nylock Nuts. Create two (2) assemblies.

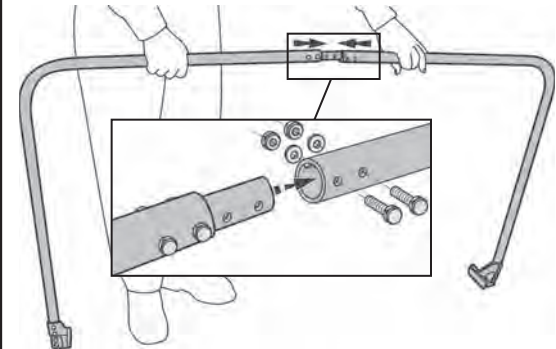

2 Install Gussets on Tube Assemblies

Use two (2) 1/4-20 x 1-3/4" Hex Head Cap Screws, 1/4" Washers and 1/4-20 Nylock Nuts to install the Left Gussets on the Left Tube Assemblies. Repeat with the Right Gussets and Right Tube Assemblies.

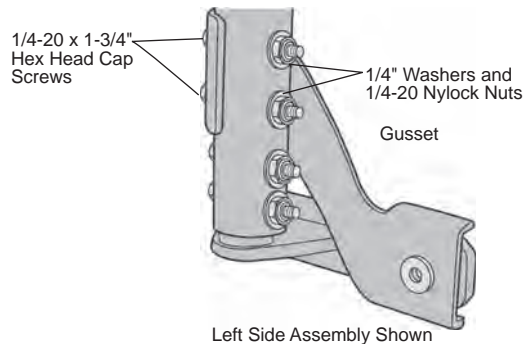

3 Install Adjustable Handles on Tube Assemblies

Thread an Adjustable Handle into the hole in the Gusset on each Tube Assembly.

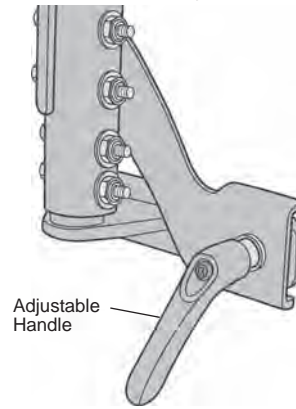

5 Install Foam on Rails

Cut the Foam to match the length of each Rail. Peel the backing off a little at a time and press the Foam firmly into place on the back of the Rail. Repeat with both Rails.

HighRock 4x4™ Overhead Rack – Installation Instructions

6 Install Rail Assemblies

Place a Rail Assembly along the side of the vehicle. Slide a Clamp under the ledge at each end of the Rail and use a 1/4-20 x 2" Hex Head Cap Screw to secure the Rail to each Clamp. Repeat on both sides of the vehicle.

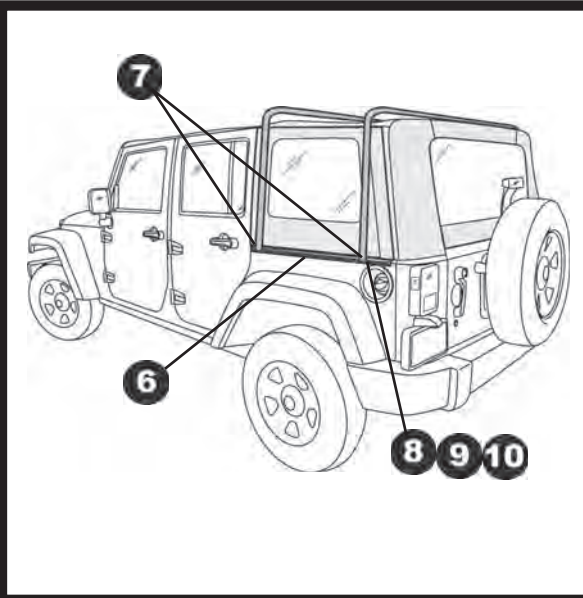
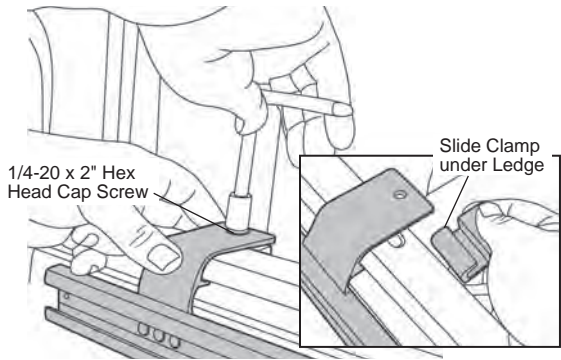

9 Cut Plastic Strip at Marked Locations

Use wire cutters to snip the plastic strip along the bottom of the top at the marked locations. Do not cut the fabric.

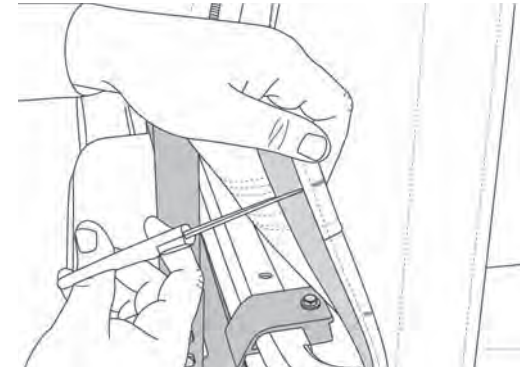

7 Install Tube Assemblies in Rails

Slide the Tube Assemblies into the Rails on each side of the vehicle. Tighten the Adjustable Handles. Repeat with both assemblies.

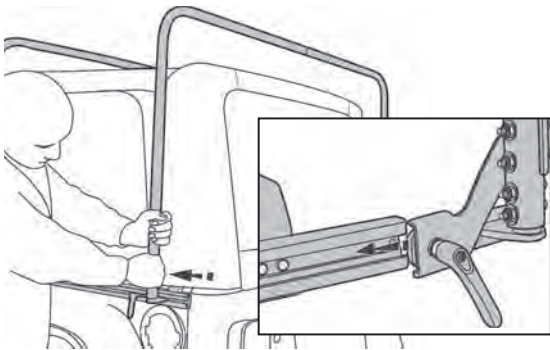

8 Mark Clamp Locations

Mark the locations of the rear Clamps on the soft top. Measure 3/4" in front of and behind each clamp and mark these locations on the rear corners of the top.

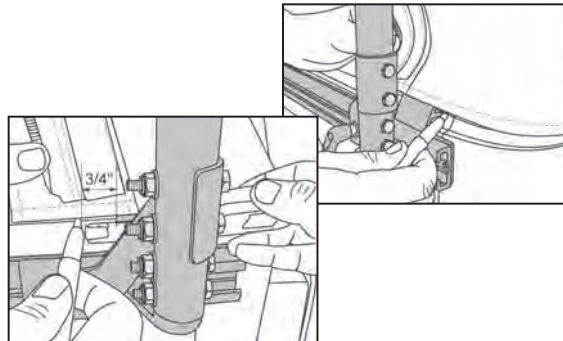

10 Notch Plastic Strip

Use a utility knife to score the plastic strip between the marks. Score the plastic enough to allow you to break it off. Do not cut the fabric.

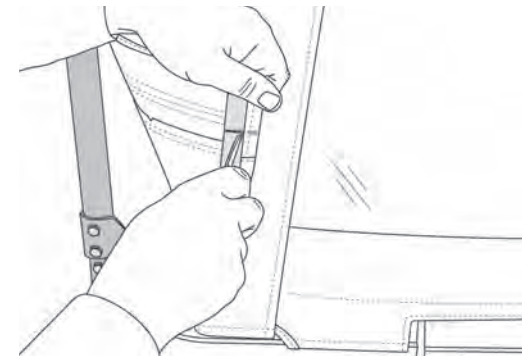

HighRock 4x4™ Overhead Rack – Installation Instructions

11 Cut Notches for Front Clamps

Repeat Steps 8 – 10 for the Front Clamps, marking the locations on the Quarter Windows.

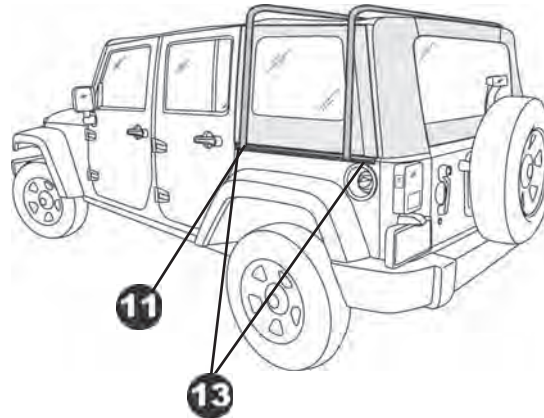
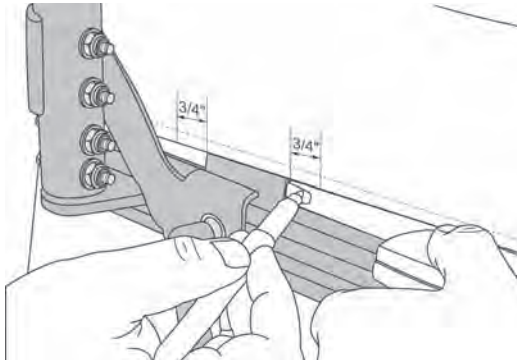

12 Install Rack Tray

Use the Tray Clamps, 1/4-20 x 1/2" Hex Head Cap Screws and 1/4" Flat Washers to mount the Rack Tray to the Overhead Rack.

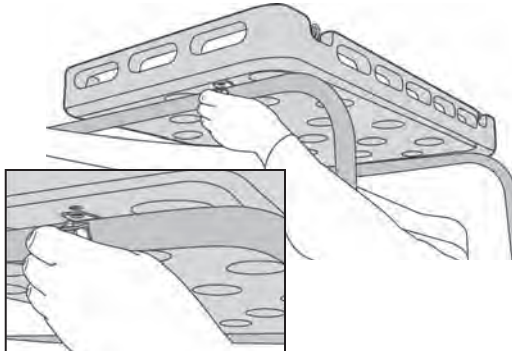

13 Install Socket Head Screws in Rail Channel

Use an allen wrench to install the four (4) #10-32 Socket Head Screws in the ends of the Rail Channels.

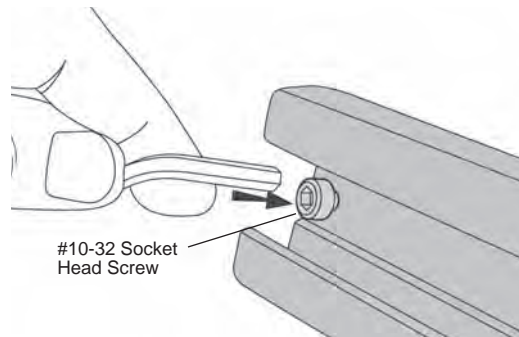

HighRock 4x4™ Overhead Rack – Installation Instructions

LIMITED WARRANTY

We warrant our product to be free from defects in material and workmanship, for the terms specified below, provided there has been normal use and proper maintenance. This warranty applies to the original purchaser only. All remedies under this warranty are limited to the repair or replacement of any item or items found by the factory to be defective within the time period specified. If you have a warranty claim, first you must call our factory at the number below for instructions. You must retain proof of purchase and submit a copy with any items returned for warranty work. Upon completion of warranty work, if any, we will return the repaired or replaced item or items to you freight prepaid. Damage to our products caused by accidents, fire, vandalism, negligence, misinstallation, misuse, Acts of God, or by defective parts not manufactured by us, is not covered under this warranty.

THE WARRANTY TIME PERIOD IS AS FOLLOWS FOR REPLACE-A-TOP™, SAILCLOTH REPLACE-A-TOP™, SUPERTOP®, SUPERTOP® REPLACEMENT SKINS, SUNRIDER®, AND TIGERTOP®: TWO YEARS FROM DATE OF PURCHASE.

THE WARRANTY TIME PERIOD IS AS FOLLOWS FOR ALL OTHER “SOFT GOODS” MANUFACTURED BY OUR COMPANY (USING PRIMARILY VINYL, PLASTICS, AND/OR FOAM): ONE YEAR FROM DATE OF PURCHASE.

THE WARRANTY TIME PERIOD IS AS FOLLOWS FOR ALL OTHER “HARD GOODS” MANUFACTURED BY OUR COMPANY (USING PRIMARILY METALS, PLASTICS, AND/OR FIBERGLASS): ONE YEAR FROM DATE OF PURCHASE.

ANY IMPLIED WARRANTIES OF MERCHANTABILITY AND/OR FITNESS FOR A PARTICULAR PURPOSE CREATED HEREBY ARE LIMITED IN DURATION TO THE SAME DURATION AND SCOPE AS THE EXPRESS WRITTEN WARRANTY. OUR COMPANY SHALL NOT BE LIABLE FOR ANY INCIDENTAL OR CONSEQUENTIAL DAMAGE.

Some states do not allow limitations on how long an implied warranty lasts, or the exclusion or limitation of incidental or consequential damages, so the above limitations or exclusions may not apply to you. This warranty gives you specific legal rights, and you may also have other rights which vary from state to state.



For further information or request for warranty work, please contact:
Bestop Inc., Customer Service
Toll-Free: (800)845-3567
Main: (303)465-1755
E-mail: csbestop@Bestop.com
Website: www.Bestop.com