



Installation Instructions

HOSS™



Hardtop Organized
Storage System





Hardtop Cart Only

Application:

- 2007 Jeep Wrangler, Wrangler Unlimited
2 and 4 Door Hard Top
Storage System
Part Number: 42806

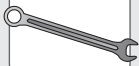
www.Bestop.com - We're here to help! Visit our web site and click on ["Ask a Question"](#). Click here for more [Jeep Accessories by Bestop](#).

INSTALLATION TIME	SKILL LEVEL
 2 Hours	 2 - Moderately Easy

TOOLS			
 Wrench 7/16", 3/4" and 9/16"	 Tape Measure	 Phillips Screwdriver	 Safety Glasses

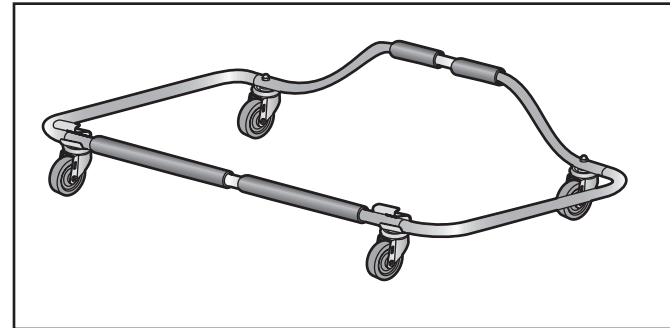

HOSS™ Top Cart Installation Instructions

Parts List and Hardware Identification

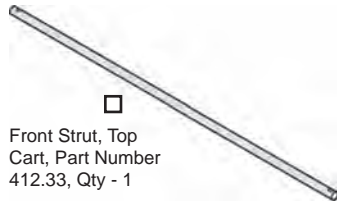

□
Front Strut, Top
Cart, Part Number
412.33, Qty - 1

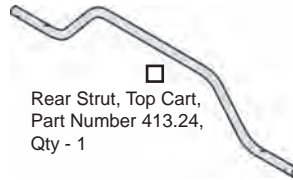

□
Rear Strut, Top Cart,
Part Number 413.24,
Qty - 1



□
Short Foam Tube, Part
Number 412.41, Qty - 2

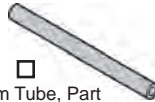

□
Long Foam Tube, Part
Number 412.40, Qty - 2

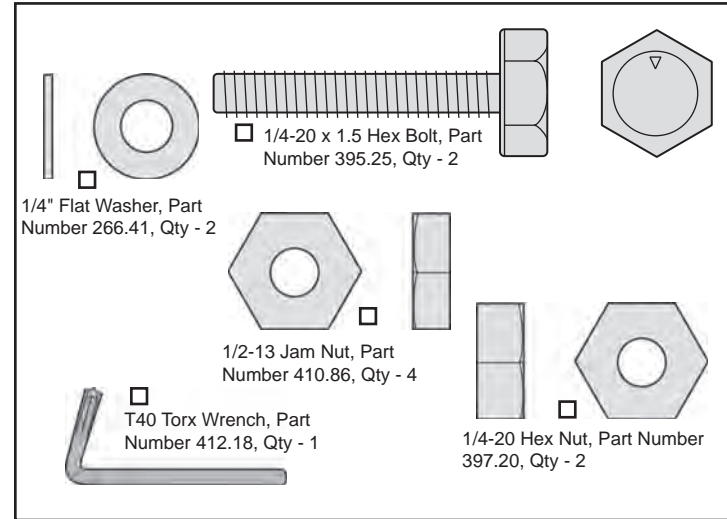

□
1/4" Flat Washer, Part
Number 266.41, Qty - 2

□
1/4-20 x 1.5 Hex Bolt, Part
Number 395.25, Qty - 2

□
1/2-13 Jam Nut, Part
Number 410.86, Qty - 4

□
T40 Torx Wrench, Part
Number 412.18, Qty - 1

□
1/4-20 Hex Nut, Part Number
397.20, Qty - 2



□
Left Corner Hook, Top
Cart, Part Number 413.23,
Qty - 1

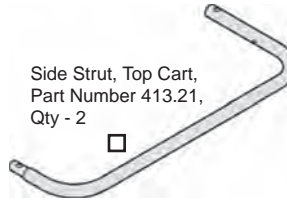

□
Side Strut, Top Cart,
Part Number 413.21,
Qty - 2



□
Caster, Top Cart, Part
Number 409.59, Qty - 2

□
Top Cart Strap, Part
Number 413.60, Qty - 1

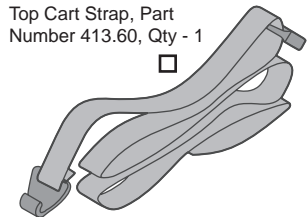

□
Corner Hook Rubber
Pad, Part Number
412.42, Qty - 2



□
Right Corner Hook, Top
Cart, Part Number 413.22,
Qty - 1



□
Braking Caster, Top Cart,
Part Number 412.45,
Qty - 2

HOSS™ Top Cart Installation Instructions

1 Install Long Foam Tubes on Front Strut - Top Cart

Locate the Top Cart Front Strut and two (2) of the Long Foam Tubes in the parts kit. Slide the sleeves over the strut and center them with a 2" space between them.

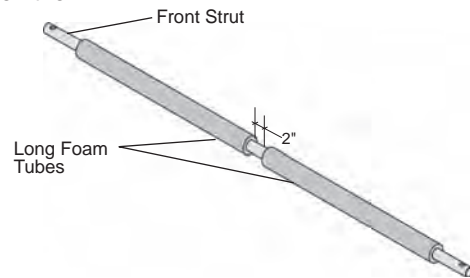

2 Install Short Foam Tubes on Rear Strut - Top Cart

Locate the Top Cart Rear Strut and the two Short Foam Tubes in the parts kit. Slide the sleeves onto the strut and center them with a 2" space between them.

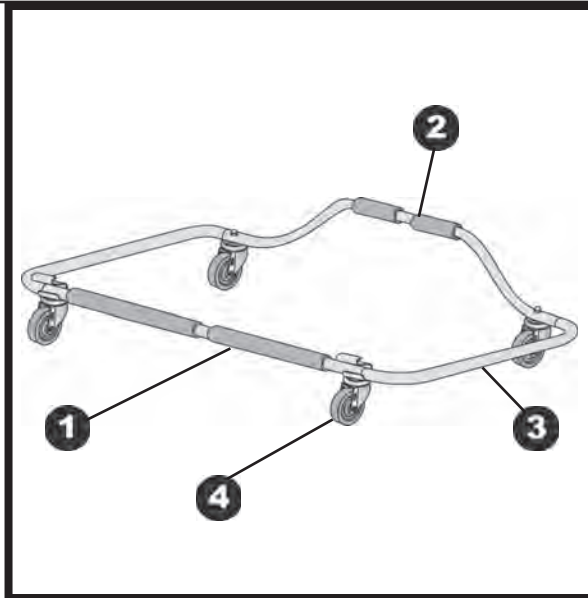
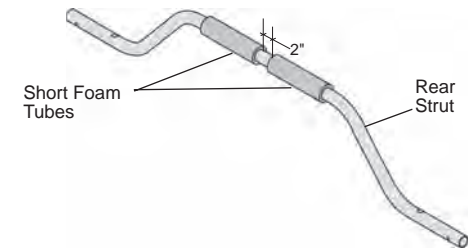

3 Assemble Top Cart Struts

Orient the Front, Rear and Side Struts to each other. Slide them together and line up all the holes.

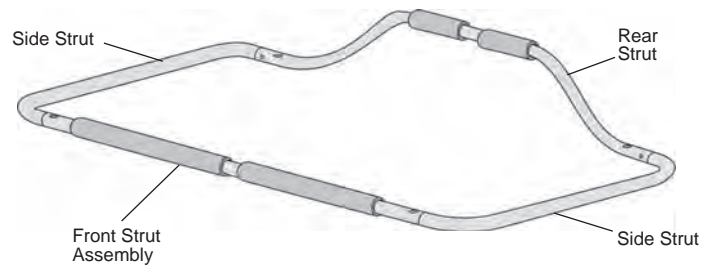

4 Secure Front and Right Side Strut - Top Cart

Slide the Right Corner Hook onto the Front Strut. Place a 1/2-13 Jam Nut over the hole in the Front Strut. Install a Top Cart Braking Caster through both struts, the hook and into the Jam Nut.

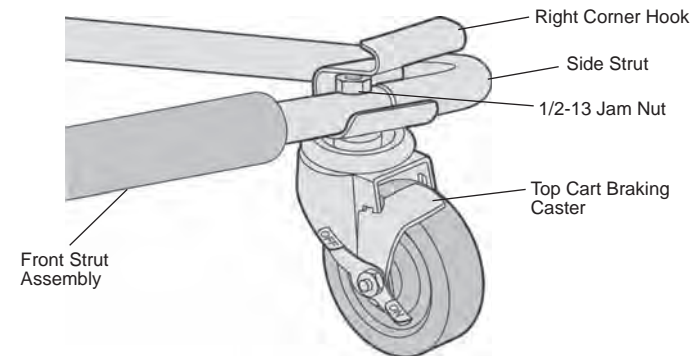

HOSS™ Top Cart Installation Instructions

5 Secure Rear Strut to Top Cart Assembly

Place a Top Cart Caster without a brake through the larger holes where the Side and Rear Struts join and secure it with a 1/2-13 Jam Nut. Then install a 1/4-20 x 1.5" Hex Bolt, a 1/4" Washer and a 1/4-20 Hex Nut.

Repeat this procedure with the other Side Strut / Rear Strut Assembly.

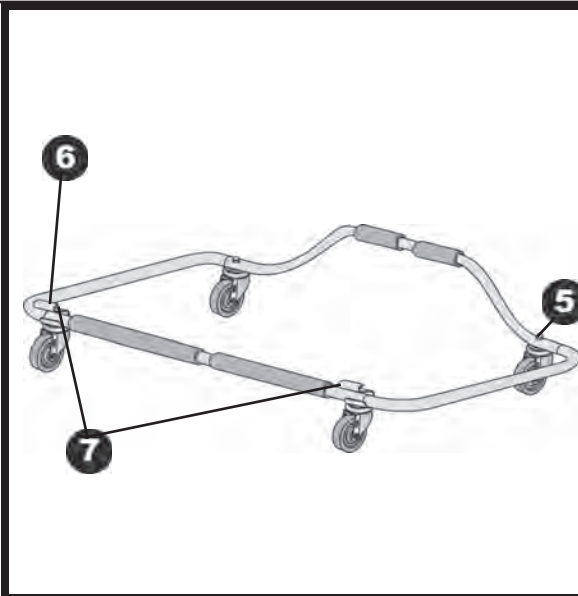
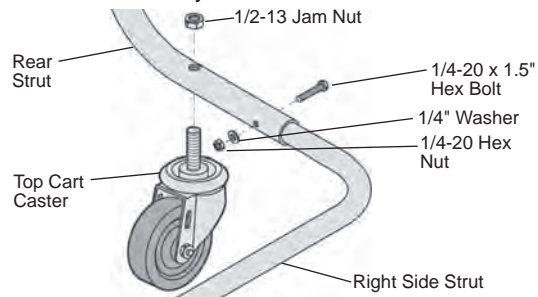

7 Install Corner Hook Rubber Pads - Top Cart

Locate the Corner Hook Rubber Pads in the parts kit. Clean the flat area on the Corner Hooks.

Orient the Corner Hook Rubber Pads to fit squarely on the Corner Hooks. Remove the backing from the pads and press them firmly onto the Corner Hooks.

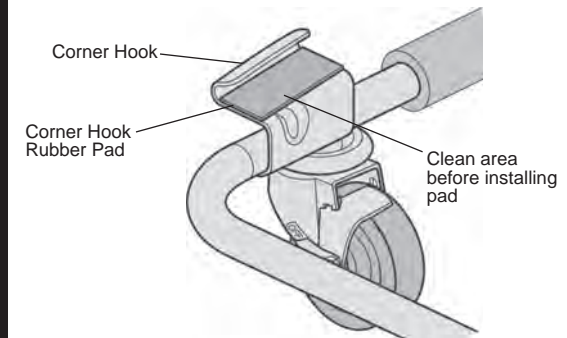

6 Install Left Front Braking Caster and Corner Hook - Top Cart

Slide the Left Corner Hook onto the Front Strut. Slide the end of the Left Side Strut into the end of the Front Strut Assembly. Place a 1/2-13 Jam Nut over the hole in the Front Strut. Install a Top Cart Braking Caster through both struts, the hook and into the Jam Nut. Securely tighten all hardware.

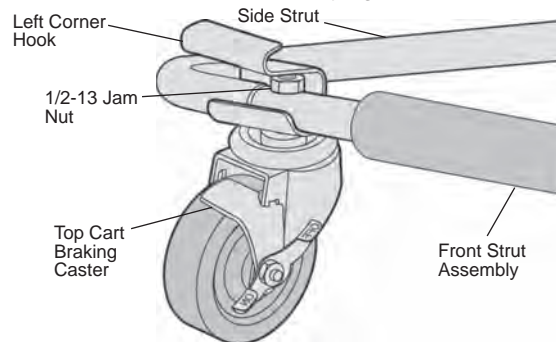

HOSS™ Top Cart Installation Instructions

8 Removing your OEM Hardtop

Release the levers that secure the SunTops to the windshield. Release the knobs that secure the SunTops to the rear deck. Release the Levers. Remove the SunTops from the vehicle.

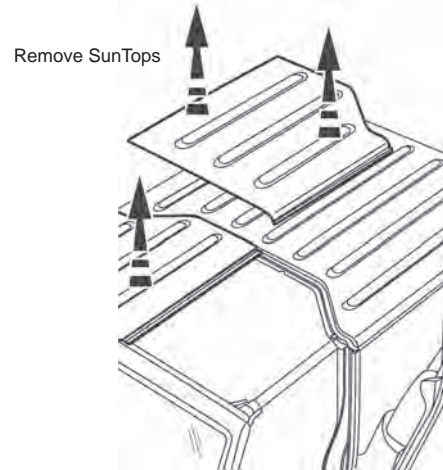
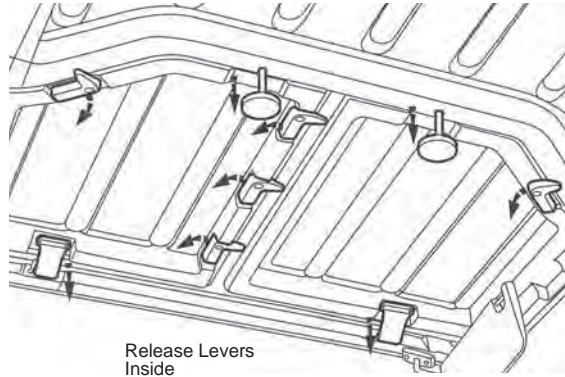

9 Removing your Hardtop

Use the T40 Torx Wrench to remove the six (6) Torx Bolts that secure the 2 Door Hardtop or the eight (8) Torx Bolts that secure the 4 Door Hardtop.

Carefully store the bolts to be used when reinstalling the top.

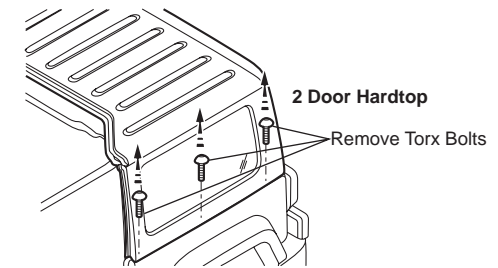

8 Removing your Bestop Hardtop

Release the knobs that secure the Sun Roof to the vehicle. Remove the Sun Roof.

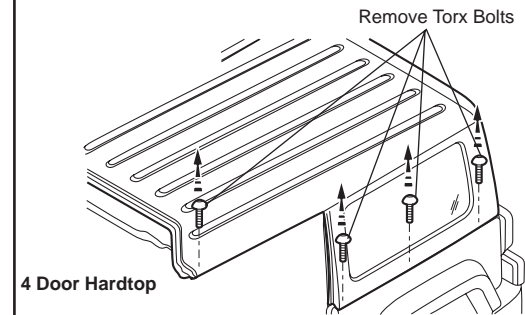
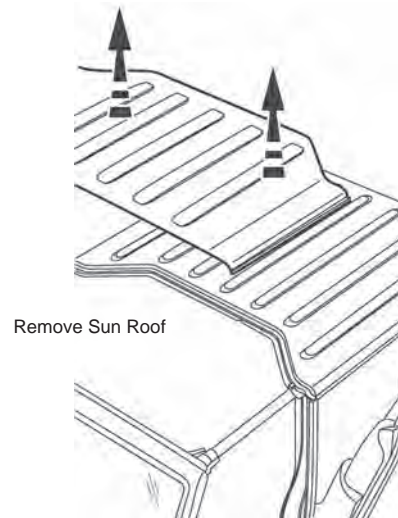
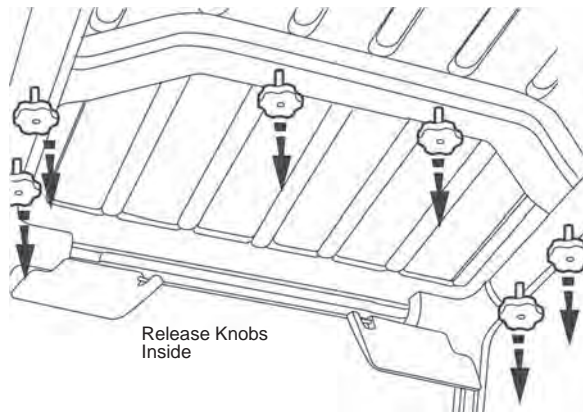

HOSS™ Top Cart Installation Instructions

10 Install Strap on Top Cart

Orient the Top Cart Strap with the buckle facing the rear of the Top Cart. Wrap the straight end of the strap around the Rear Strut in the space between the two Foam sleeves. Pull it toward the buckle in the middle of the strap without twisting. Thread the end of the strap through the buckle.

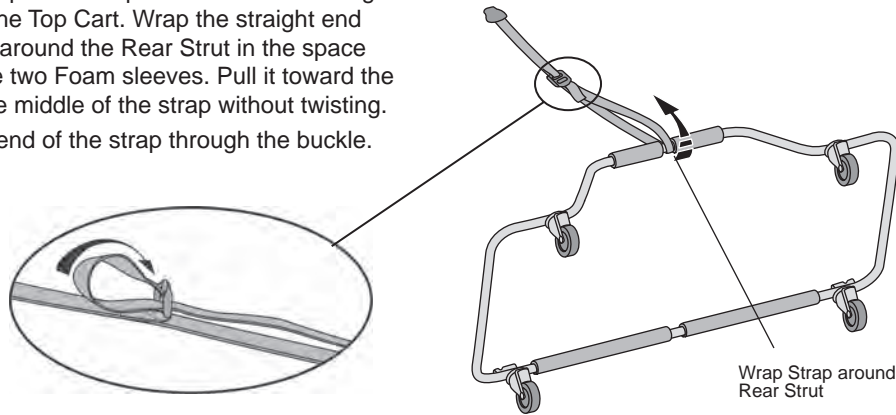

CAUTION Four or more people are required to lift the hardtop safely.

11 Removing your Hardtop

Slide the top back slightly, but leave on the vehicle.

Place the Top Cart against the rear of the top with the Rear Tube toward the top.

Position Right and Left Corner Hooks on the cart under the rear flange of the hardtop for maximum support.

Hook the strap to the front of the hardtop. Pull the strap as tight as possible.

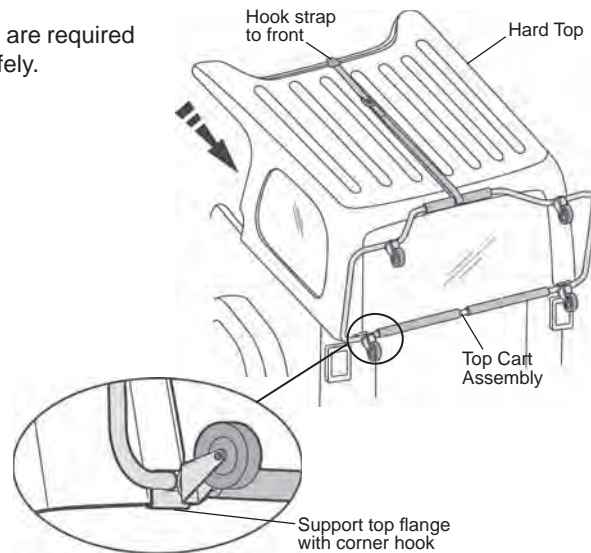

CAUTION

Four or more people are required to lift the hardtop safely.

12 Removing your Hardtop

Use the Side Struts as handles to lift the hardtop and Top Cart off the vehicle and move toward the rear. Slowly place the top in its normal position down on the ground next to the vehicle. Recheck that the strap is secure.



HOSS™ Top Cart Installation Instructions



CAUTION

Two or more people are required to lift the hardtop safely. DO NOT allow the hardtop to rock backwards while lifting.

13 Removing your Hardtop

Lock the Front Brake Casters. Slowly lift the front of the hardtop until it is completely resting on the Top Cart Casters. Do not allow the hardtop to rock backwards as it approaches the full upright position.

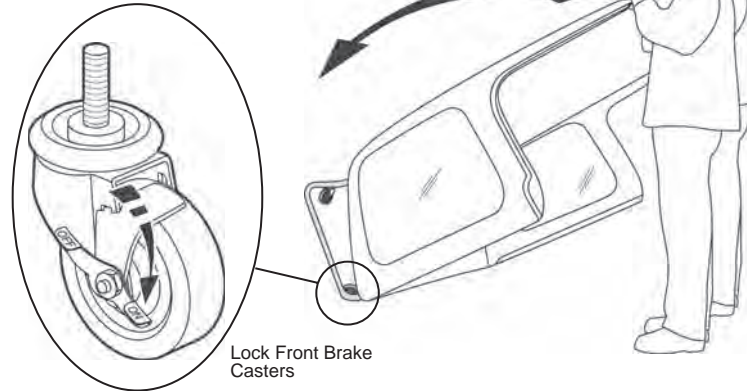

14 Storing your Hardtop

Release the Front Brake Casters and roll the hardtop/cart assembly into position for storage. Once the cart is in this position, again lock the front casters.

Limited Warranty

We warrant our product to be free from defects in material and workmanship, for the terms specified below, provided there has been normal use and proper maintenance. This warranty applies to the original purchaser only. All remedies under this warranty are limited to the repair or replacement of any item or items found by the factory to be defective within the time period specified.

If you have a warranty claim, first you must call our factory at the number below for instructions. You must retain proof of purchase and submit a copy with any items returned for warranty work. Upon completion of warranty work, if any, we will return the repaired or replaced item or items to you freight prepaid. Damage to our products caused by accidents, fire, vandalism, negligence, misinstallation, misuse, Acts of God, or by defective parts not manufactured by us, is not covered under this warranty.

THE WARRANTY TIME PERIOD IS AS FOLLOWS: ALL "PRODUCTS" MANUFACTURED BY OUR COMPANY: ONE YEAR FROM DATE OF PURCHASE.

ANY IMPLIED WARRANTIES OF MERCHANTABILITY AND/OR FITNESS FOR A PARTICULAR PURPOSE CREATED HEREBY ARE LIMITED IN DURATION TO THE SAME DURATION AND SCOPE AS THE EXPRESS WRITTEN WARRANTY. OUR COMPANY SHALL NOT BE LIABLE FOR ANY INCIDENTAL OR CONSEQUENTIAL DAMAGE.

Some states do not allow limitations on how long an implied warranty lasts, or the exclusion or limitation of incidental or consequential damages, so the above limitations or exclusions may not apply to you.

This warranty gives you specific legal rights, and you may also have other rights which vary from state to state.



For further information or request for warranty work, please contact:
Bestop Inc. Customer Service
(800) 845-3567
(303) 465-1755