

Trench Drain Installation Guide

Component Identification

| Item | Description |
|------|----------------------|
| 1 | Trench Drain Channel |
| 2 | Grate |
| 3 | Fasteners & Screws |
| 4 | Open End Cap |
| 5 | Closed End Cap |
| 6 | Mounting Bracket |
| 7 | Inline Sand Trap |
| 8 | Debris Basket |
| 9 | Sand Trap End Caps |

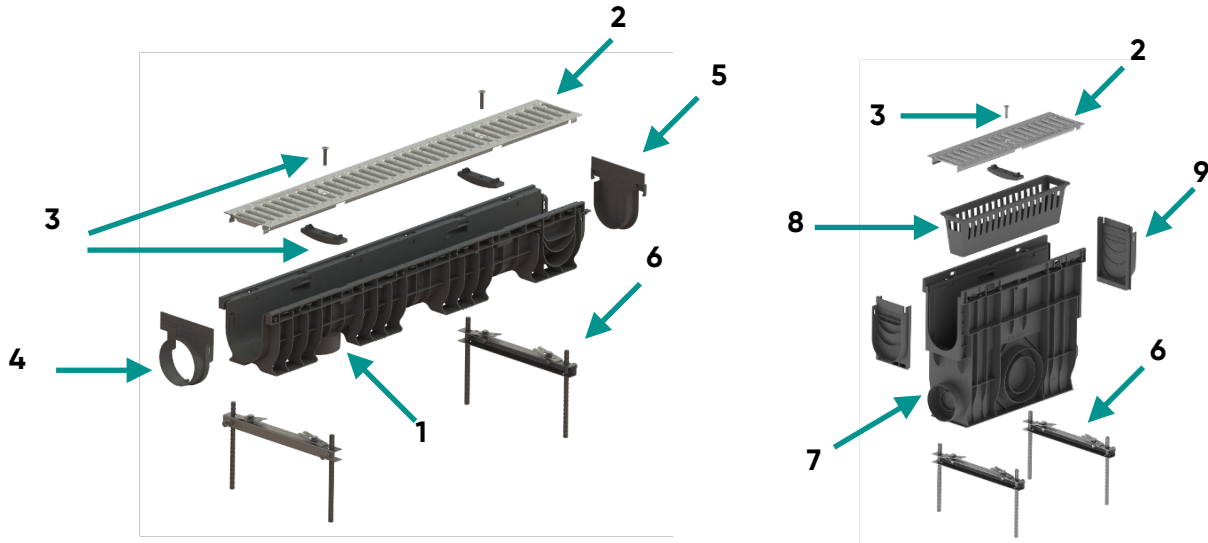

Channel Preparation

The Standartpark Canada PPE plastic channels are designed with universal purpose in mind. All channels have a possible outlet from the bottom, and the larger channels have additional outlet options on the side and from the end caps. These outlets come sealed and simply need to be cut out.

The same preparation applies for using the 90-degree channel connection. All of our channels have an outlet to allow a 90-degree connection to another channel. This section must be cut out and has several cut-out sizes available. Make sure you cut out the appropriate size for the channel you are connecting.

End caps

All Standartpark Canada channels come with end caps to enclose the channel at the end of your trench drain line. The installation of end caps is quite simple overall but many of our end caps have slight differences which require a different installation process.

The first step is identifying which connection side of the channel (male or female) you will be connecting the end cap to:

- For the female side, all that must be done is apply silicone sealant and then connect the end cap
- For the male side, you will need to cut off the male connection that protrudes from the channel and then proceed as if it was the female side
- Some end caps may need to slide into a slot, some may need to just be applied to the outside, and some have clip-on pieces to provide a more secure fit.
- Certain end caps have an outlet option. Most outlet end caps come already cut but some require that you cut out the outline of the hole.

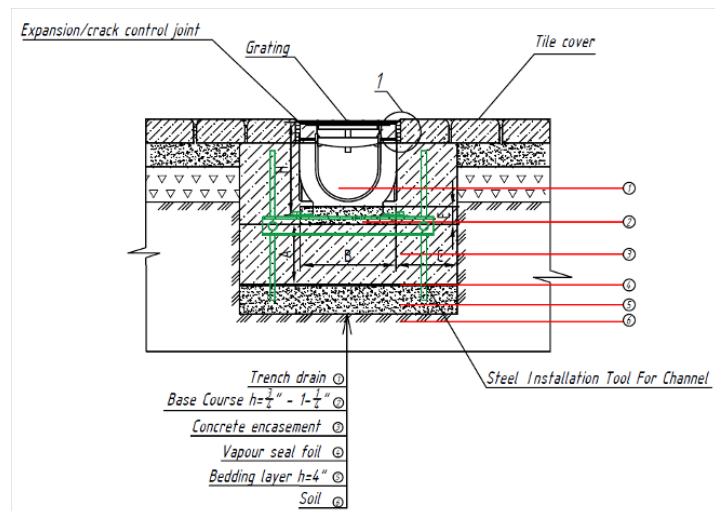

Installation Preparation

There are several steps you must take prior to installation and pouring the concrete.

Standartpark trench drain channels are installed to be level with the floor and are recommended to be encased in concrete. This means that an appropriately sized trench must be dug in the location that the system will be installed. The trench should be dug in accordance to the size of channel plus the additional dimensions for the concrete. Standartpark Canada recommends that **the trench be 3-5 inches wider than the channel on both sides and 2-4 inches of depth below the channel** for the concrete base.

Standartpark trench drains can be installed with tile or concrete on the surface. Tile installation is the exact same as concrete but you must account for the tile when measuring for the height of the concrete.

When installing the channel in concrete, it is recommended that **the grates are secured in the channel prior to installation to prevent the channel from being warped** from the weight of the concrete. At the same time, you want to prevent the concrete from making contact with the grate and seeping into the channel. That's why it is recommended to cover the grates prior to installation. It is recommended that you **cover the grates with plastic, tape, or plywood for the best protection.**



It is essential that you understand how to set up your system and account for any connections to your system prior to pouring your concrete. While the "Mounting Bracket" installation method will allow you to fully set up your system before the concrete is poured, the "Pad and Pour" method requires your system be set up on an existing base of concrete. For this reason, it is important that you consider which outlets or connections need to be set up before pouring the base.

Channel Installation

Types of Installation

There are two types of installation that can be used for our trench drain channels.

1. **Concrete Pad and Pour Installation** (Traditional)
2. **Mounting Bracket Installation** (Recommended) (Required for Cascade Depth System)

Pad and Pour Installation

If you are doing a concrete installation without the use of mounting brackets, these are your step-by-step instructions:

1. Inspect to make sure your trench meets the desired dimensions for the entire system.
2. When pouring concrete, make sure the base (2-4 inches) is leveled out according to your site plan. Wait for the concrete to cure for at least 2 days before moving on.
3. Set your channels on the concrete pad, attach together and connect your pipe outlets according to your design. Pipe connections are designed for PVC and Drainage tile – if you wish to utilize a corrugated pipe, please use a rubber coupling with clamps. That makes for a snug fit. Seal all

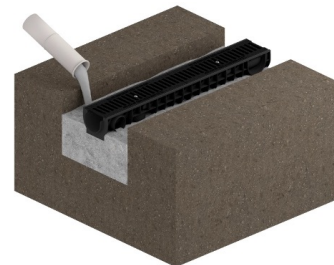

channels with Standartpark silicone or an equivalent and make sure they are water tight and dry before your final concrete pour.

4. Standartpark recommends leaving your gratings in the channel when you are doing your final pour – this will alleviate any instances of your channels being altered while the concrete sets. This is important so your gratings fit nice and snug after the concrete settles. (It is incredibly important that if you purchased an inline sand trap for your system, that you follow this rule and have the grating with connecting brackets placed in the sand trap when pouring concrete) Your left in grating should already be covered, if not then do so now to prevent concrete from making its way in the channel while pouring.

5. Pour around sides of the channel and wait for the concrete to set.

Mounting Bracket Installation

With our installation using mounting brackets, you're able to level your system in the trench before concrete is poured. It also allows the concrete to be poured all at once, making installation quicker and more efficient.

1. Make sure you dig and prep your site exactly to your specifications. Make sure all outlet pipe locations are aligned. And that you have enough width and depth in your trench to comfortably place your installation mounting brackets inside. (Systems like cascade mean that there may be varying depths throughout the trench)
2. Loosen the mounting bracket and leveling bolts. Place the "V" clip of your mounting bracket into the channel connections, or on the channel itself.
3. Make sure your channel connections are water tight (we recommend a silicone in between the channel joints) and that end caps are tight and sealed off as well.
4. Place your entire system into the trench. Make sure the rebar holding bolts are loose and will allow rebar to enter.
5. Insert rebar through the mounting bracket and into your ground – lift up on the channels and tighten the mounting brackets – level your entire system.
6. Double check your channel connections – and secure your pipe outlet connections – make sure system is level – we recommend leaving gratings in during pour.
7. Double check all rebar leveling bolts – they are tight and snug.
8. Pour your concrete and wait to settle.

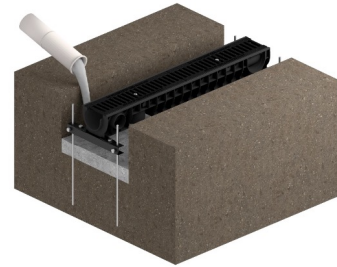

FAQ's

- **How to connect channels:**

Some of our channels have a snap and lock connection – Some have a slide in connection due to male-female ends (used for straight and gradual curve situations). All you need to do is seal the connection. We recommend a silicone (clear/water based) for water tight.

- **How to connect the outlet pipe:**

All pipes are not rated the same, just as they are not sized the same. However, the basis of design will work for all sizes. If you find that your PVC or corrugated piping is a little too large, or a little too small – just use a rubber coupling with hose clamps. They create a nice snug fit and provide water proofing during your installation.

- **How to properly install an inline sand trap:**

It is incredibly important to have the grate remain in the sand trap during installation due to the possibility of the weight of the concrete warping the sand trap channel. It is also important to use a brace to support the middle of the trap as the depth makes the middle especially vulnerable to warping. We recommend pinning a piece of wood in the middle of the trap prior to installation to solve this issue. Not following these steps may result in a sand trap that doesn't meet the load class requirements and also difficulties in removing the debris basket.

Standartpark fully stands behind each and every one of our products. We always urge our customers to email or call us with any questions. If you ever have any issues or concerns, we would like to hear them, please send us an email at info@standartpark.ca

Thank you again for your business!

Please note: All the specifications, drawings, and installation schemes can be found and downloaded on our website. Go to the product page and you'll find tabs for all these options at the bottom of the page. Installation videos can also be found on YouTube at:

Standartpark Canada.

Contact us:

Tel: +1 (905) 238-1771

info@standartpark.ca

www.standartpark.ca

YouTube: Standartpark Canada