

Slot Drain Installation Guide

Slot Type

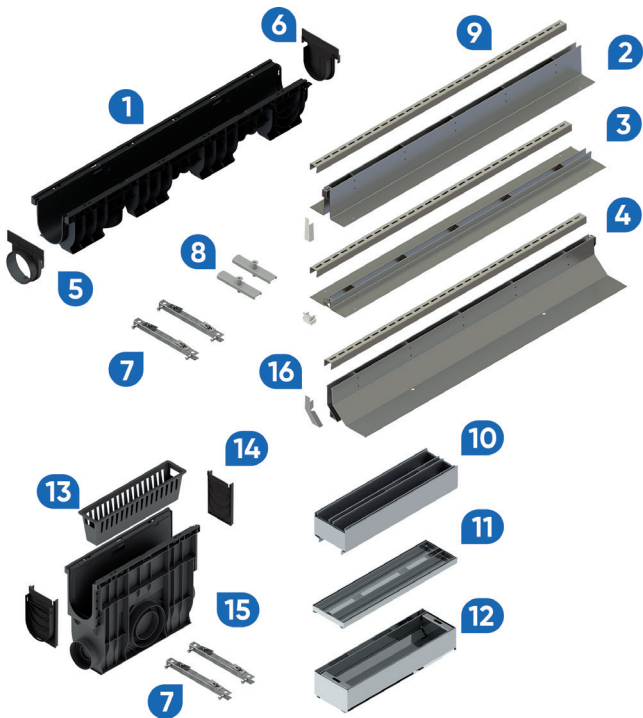

Component Identification:

Item	Description	Item	Description
1	Trench Drain Channel	9	Slot Cover
2	Standard Slot Drain	10	Clean-out slot Standard
3	Micro Slot Drain	11	Clean-out slot Micro
4	Wall Slot Drain	12	Clean-out slot Wall
5	Open End Cap	13	Debris basket
6	Closed End Cap	14	End Cap for Sand trap
7	Mounting Bracket	15	Inline Sand Trap (optional)
8	Connecting Screws & Fasteners	16	Slot drain End Cap

There are three types of slot drains that we offer:

- **Standard Slot Drain** – the slot has 4" in height above the channel.
- **Micro Slot Drain** – the slot has 1" in height above the channel.
- **Wall Slot Drain** – the slot has 4" in height above channel installed against an existing wall/slab.

Each slot type follows the same standardized instructions but you must be aware of the subtle differences in each installation method based off the slot type you have. Each

slot type has slight differences in required depth of trench. The "Mounting Bracket" installation is not available for Wall Slot drains.

Channel preparation

The Vodaland Canada PPE plastic channels are designed with universal purpose in mind. All channels have a possible outlet from the bottom, and the larger channels have additional outlet options from the end caps. The bottom outlets come sealed and simply need to be cut out, while the end cap outlets just need to be connected to the end of the channel.

All of our channels have 90-degree connection options as well which can be fit onto the end of another channel. This section must be cut out and provides several cut-out sizes to connect different depths and widths of channels together. Make sure you cut out the appropriate size for the channel you are connecting. Then an end cap will be needed to close off the open end of the 90-degree to create a corner.

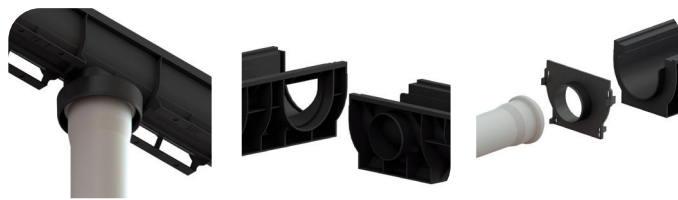

End Caps

All Vodaland Canada channels come with end caps to enclose the channel at the end of your trench drain line. The installation of end caps is quite simple overall but many of our end caps have slight differences which require a different installation process. The first step is identifying which connection side of the channel (male or female) you will be connecting the end cap to:

- For the male side, all that must be done is apply silicone sealant and then connect the end cap.
- For the female side, you will need to cut off the connection that protrudes from the channel and then proceed as if it was the male side.
- Some end caps may need to slide into a slot, some may need to just be applied to the outside, and some have clip-on pieces to provide a more secure fit. Speak to a Vodaland representative if you need assistance identifying which end cap type you have.
- Certain channels have end cap outlet options. It is important that outlet end caps connect to the male connection side for most ideal seal.
- Included with the channel end caps, you will also receive stainless steel slot end caps that cover the ends of the slot. The side of the slot with the protruding connection piece can also be bent to cap off that end.



Installation preparation

There are several steps you must take prior to installation and pouring the concrete. Vodaland slot drain channels are installed to be level with the floor and are recommended to be fully encased in concrete. This means that an appropriately sized trench must be dug for the location that the system will be installed. The trench should be dug in accordance to the size of channel and slot, plus the additional dimensions for the concrete encasement. The width and depth of concrete encasement changes depending on the load class that the trench drain must meet. Use the table below to identify appropriate encasement size:

Load class	Class A	Class B	Class C
Concrete Encasement Depth (Inches)	3.2	4	6
Concrete Encasement Width (Each Side*) (Inches)	3.2	4	6

*The wall slot drain only requires concrete encasement on the opposite side of the wall it is going up against.

Slot drains can be installed with tile or concrete on the surface. Tile installation is the exact same as full concrete installation, but you must account for the tile height when measuring for the height of the concrete encasement.

When installing slot drains, the slot and the channel are to be fully encased in concrete so the top of the slot is the only part to be showing. At the same time, you want to prevent the concrete from making contact with the slot and seeping into the channel. That's why it is recommended to cover the slot prior to installation. It is recommended that you cover the slots with plastic, tape, or a thin piece of wood for the best protection.

It is essential that you understand how to set up your system and account for any connections to your system prior to pouring your concrete. While the "Mounting Bracket" installation method will allow you to fully set up your system before the concrete is poured, the "Pad and Pour" method requires your system be set up on an existing base of concrete. For this reason, it is important that you consider which outlets or connections need to be set up before pouring the base.

Channel installation

Types of Installation

There are three types of installation that can be used for our trench drain channels.

- **Pad and Pour Installation** (Traditional)
- **Mounting Bracket Installation** (Recommended) (Required for Cascade Depth System)



Pad and Pour Installation



Mounting Bracket Installation

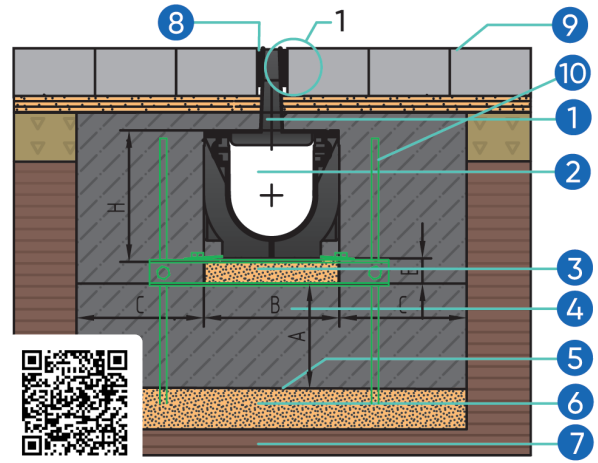

scan for video

1. Slot Drain
2. Trench drain
3. Base Course $h = \frac{3}{4}'' - 1\text{-}\frac{1}{4}''$
4. Concrete encasement
5. Vapour seal foil
6. Bedding layer $h = 4''$
7. Soil
8. Expansion/crack control joint
9. Tile cover
10. Steel Installation Tool For Channel

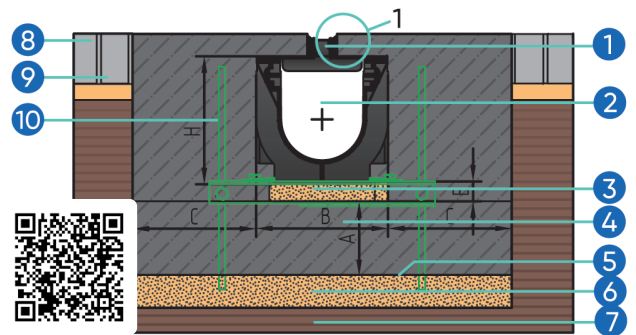
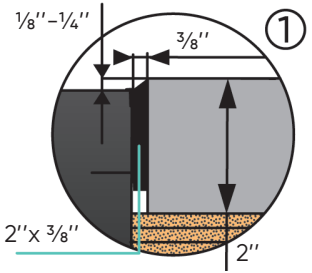

1. Micro Slot Drain
2. Trench drain
3. Base Course $h = \frac{3}{4}'' - 1\text{-}\frac{1}{4}''$
4. Concrete encasement
5. Vapour seal foil
6. Bedding layer $h = 4''$
7. Soil
8. Expansion/crack control joint
9. Tile cover
10. Steel Installation Tool For Channel

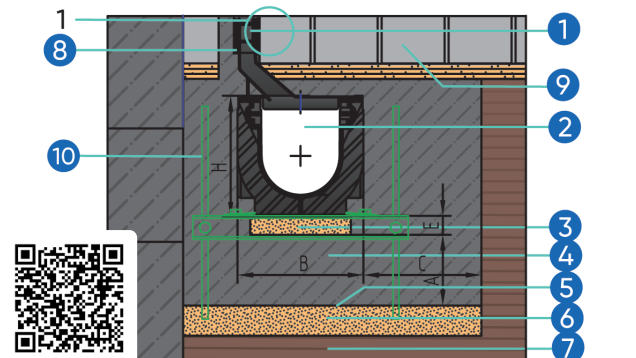
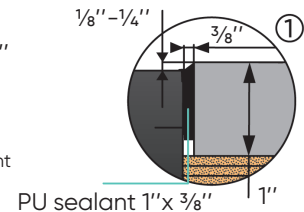

1. Wall Slot Drain
2. Trench drain
3. Base Course $h = \frac{3}{4}'' - 1\text{-}\frac{1}{4}''$
4. Concrete encasement
5. Vapour seal foil
6. Bedding layer $h = 4''$
7. Soil
8. Expansion/crack control joint
9. Tile cover
10. Steel Installation Tool For Channel

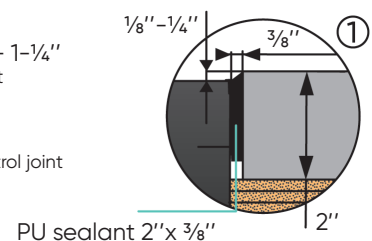

Pad and Pour Installation

If you are doing a concrete installation without the use of mounting brackets, these are your step-by-step instructions:

- 1 Inspect to make sure your trench meets the desired dimensions for the entire system.
- 2 Prepare your base: If pouring concrete, make sure the base (3-6 inches) is leveled out according to your site plan. If piping is to be connected by bottom outlet, have this piping positioned prior to pouring base. Wait for the concrete to cure for at least 2 days before moving on.
- 3 Set your channels on the concrete pad, attach together and connect your pipe outlets according to your design. Our pipe connection adapters are designed for PVC and Drainage tile – if you wish to utilize another form of piping, please use a rubber coupling with clamps. This makes for a snug fit. Seal all channels with Vodaland silicone or an equivalent and make sure they are water tight and dry before your final concrete pour.
- 4 It is required that the slots be placed in channels prior to pouring the concrete. Holes on the base of the slot allow it to be screwed onto the channel to provide additional support. Wall slot drain screws connect to fasteners instead of the channel. At this point your slot should also be covered to prevent concrete from entering the channel.
- 5 Pour around sides of the channel and slot, and wait for the concrete to set.

Mounting Bracket Installation

With our installation using mounting brackets, you're able to level your system in the trench before concrete is poured. It also allows the concrete to be poured all at once, making installation quicker and more efficient.

- 1 Make sure you dig and prep your site exactly to your specifications. Make sure all outlet pipe locations are aligned. And that you have enough width and depth in your trench to comfortably place your installation mounting brackets inside. (Cascade systems require that there be varying depths throughout the trench)
- 2 Loosen the mounting bracket and leveling bolts. Place the "V" clip of your mounting bracket into the channel legs and tighten to secure.
- 3 Make sure your channel connections are water tight with Vodaland silicone and that end caps are tight and sealed off as well.
- 4 Place your entire system into the trench. Make sure the rebar holding bolts are loose and will allow rebar to enter. We recommend #3 or 10M (3/8") rebar for this purpose.
- 5 Insert rebar through the mounting bracket and into your ground – lift up on the channels and tighten the leveling brackets – level your entire system with a bubble level.
- 6 Double check your channel/slot connections and secure your pipe outlet connections. Make sure system is level and it is required to have the slots in during pour. Insert screws in the holes at the base of the slot to connect the slot firmly to the channel and provide additional support. (Wall slot drain screws connect to fasteners instead of the channel).
- 7 Double check all rebar leveling bolts – they are tight and snug.
- 8 Pour your concrete and wait to settle.

90 Degree Turns

Our slot drains are designed with the ability to be connected as a 90-degree turn, much like the plastic channels beneath them. To create a seamless 90-degree turn for the metal slot, an adapter is needed. It serves no purpose other than filling the gap between the perpendicular slots for a better look. To close the end of the slot on 90 degree turns we sell metal slot end caps but there are other possible solutions: wood planks, extended height endcaps, or bending the existing metal on the slot.



FAQ's

How to connect channels?

Most of our trench drains have a click-in snap and lock connection, some slide into one another using the male and female connections on each channel. All that is required is to seal between the connections. We recommend our silicone sealant for the most water tight seal.

How to connect the outlet pipe?

All pipes are not rated the same, just as they are not sized the same. However, the basis of design will work for all sizes. If you find that your PVC or corrugated piping is a little too large, or a little too small – just use a rubber coupling with hose clamps. They create a nice snug fit and provide water proofing during your installation.

How to properly install an inline sand trap (clean-out system)?

It is incredibly important to have the slot remain in the sand trap during installation due to the risk of the weight of the concrete warping the sand trap channel. It is also important to use a brace to support the internal middle of the trap as the depth makes the middle especially vulnerable to warping. We recommend pinning a piece of wood in the middle of the trap prior to installation to solve this issue. Not following these steps may result in a sand trap that doesn't meet the load class requirements and also becomes difficult in removing the debris basket.



Vodaland fully stands behind each and every one of our products. We always urge our customers to email or call us with any questions. If you ever have any issues or concerns, we would like to hear them, please send us an email at info@vodaland.ca

Thank you again for your business!

Please note: All the specifications, drawings, and installation schemes can be found and downloaded on our website. Go to the product page and you'll find tabs for all these options at the bottom of the page. Installation videos can also be found on **YouTube** at: **Vodaland Canada**.

Contact us:

+1 (905) 238-1771

info@vodaland.ca

www.vodaland.ca

YouTube: Vodaland Canada