

PRO 150PC SYSTEM - LOAD CLASS D400-E600 EXPOSED CONCRETE PAVEMENT SHALLOW INSTALLATION

6" (150mm) PRO POLYMER CONCRETE TRENCH DRAIN

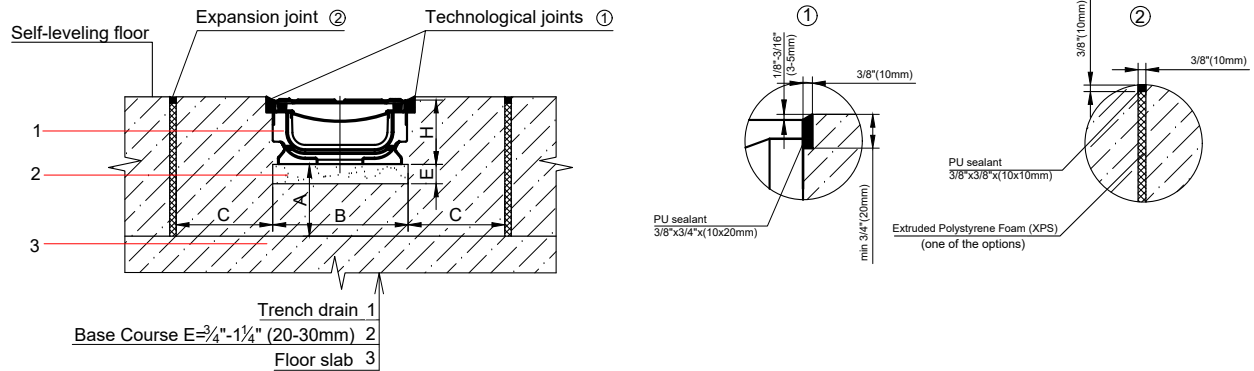

PARAMETER	LOAD CLASS	
	CLASS D	CLASS E
CONCRETE ENCASEMENT DEPTH (A), in	8" (200mm)	10" (250mm)
CONCRETE ENCASEMENT WIDTH (C), in	8" (200mm)	8" (200mm)

NOTES:

- SPECIFIER IS RESPONSIBLE FOR CONCRETE ENCASEMENT AND REINFORCING BASED UPON APPLICATION AND LOCAL CODES.
- EXPANSION AND CONTRACTION CONTROL JOINTS AND REINFORCEMENT ARE RECOMMENDED TO PROTECT CHANNEL AND CONCRETE SURROUND. ENGINEERING ADVICE MAY BE REQUIRED.
- THIS INSTALLATION SCHEME IS A RECOMMENDATION. CONSULT WITH THE MANUFACTURER FOR INSTALLATION INSTRUCTIONS.
- THE FINISHED LEVEL OF CONCRETE SURROUND SHOULD BE 1/8" - 3/16" (3-5mm) ABOVE THE TOP OF THE CHANNEL EDGE.

GENERAL: THE TRENCH DRAIN SHALL BE VODALAND CANADA PRO 150PC AS MANUFACTURED BY VODALAND OR APPROVED EQUAL.

SPECIFICATION: CHANNELS SHALL BE 39.4" (1000mm) LONG AND THE NOMINAL CLEAR OPENING SHALL BE 6" (150mm) WITH 8.3" (210mm) OVERALL WIDTH AND NEUTRAL 0% BUILT IN SLOPE. CHANNELS SHALL HAVE MALE-TO-FEMALE INTERLOCKING JOINTS. GRATINGS SHALL BE DUCTILE CAST IRON FASTENED TO STEEL EDGE RAILS AND MEET THE SYSTEM LOAD CLASS SPECIFIED. CHANNELS AND GRATE SHALL WITHSTAND A REQUIRED EN1433 LOAD CLASS.

MATERIALS: PRO 150PC TRENCH DRAIN SHALL BE MANUFACTURED FROM POLYMER CONCRETE WITH THE FOLLOWING APPROXIMATE PROPERTIES:

COMPRESSIVE STRENGTH	14,000 PSI
FLEXURAL STRENGTH	4,000 PSI
TENSILE STRENGTH	1,500 PSI
WATER ABSORPTION:	0.05%
FROST PROOF:	YES
DILUTE ACID AND ALKALI RESISTANT:	YES
SALT PROOF:	YES

THE COMPLETE DRAINAGE SYSTEM SHALL BE BY VODALAND CANADA INC. ANY DEVIATION OR PARTIAL SYSTEM DESIGN AND/OR IMPROPER INSTALLATION WILL VOID ANY AND ALL WARRANTIES PROVIDED BY VODALAND CANADA INC.

REVISED: 2023

Vodaland Canada Inc.

1-5900 Ambler Dr, Mississauga, ON L4W 2N3 • Phone: 905-238-1771 • Email: info@vodaland.ca

PRO 150PC SYSTEM - LOAD CLASS D400-E600
ENCLOSED ASPHALT PAVEMENT INSTALLATION

6" (150mm) PRO POLYMER CONCRETE TRENCH DRAIN

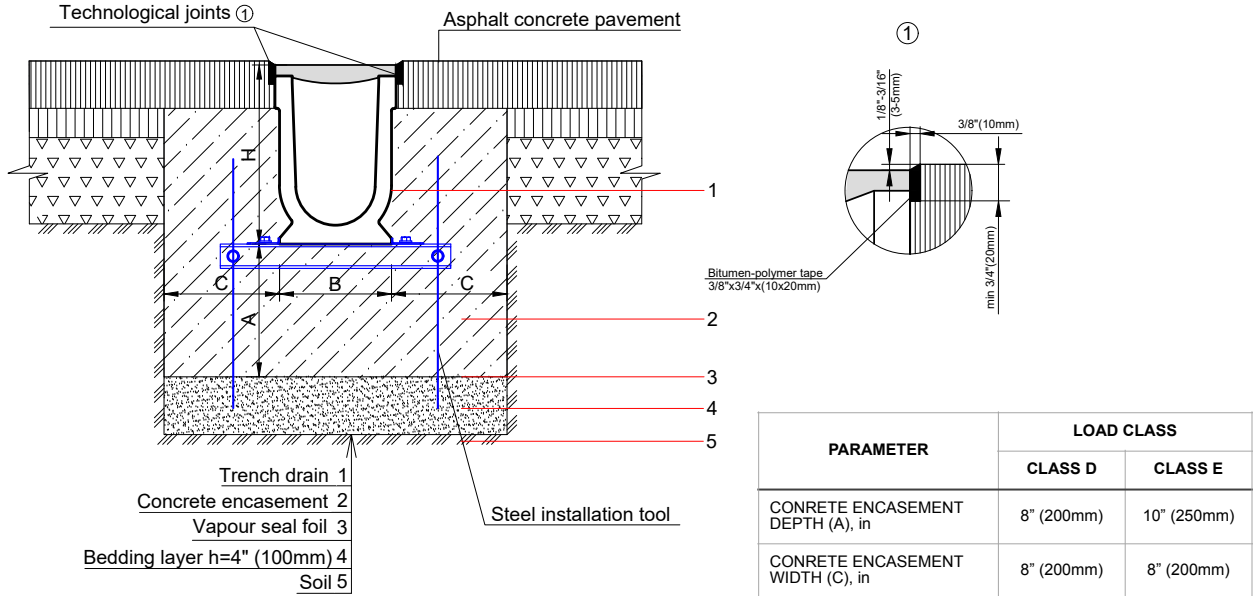

NOTES:

1. SPECIFIER IS RESPONSIBLE FOR CONCRETE ENCASEMENT AND REINFORCING BASED UPON APPLICATION AND LOCAL CODES.
2. EXPANSION AND CONTRACTION CONTROL JOINTS AND REINFORCEMENT ARE RECOMMENDED TO PROTECT CHANNEL AND CONCRETE SURROUND. ENGINEERING ADVICE MAY BE REQUIRED.
3. THIS INSTALLATION SCHEME IS A RECOMMENDATION. CONSULT WITH THE MANUFACTURER FOR INSTALLATION INSTRUCTIONS.
4. THE FINISHED LEVEL OF CONCRETE SURROUND SHOULD BE 1/8" - 3/16" (3-5mm) ABOVE THE TOP OF THE CHANNEL EDGE.

GENERAL: THE TRENCH DRAIN SHALL BE VODALAND CANADA PRO 150PC AS MANUFACTURED BY VODALAND OR APPROVED EQUAL.

SPECIFICATION: CHANNELS SHALL BE 39.4" (1000mm) LONG AND THE NOMINAL CLEAR OPENING SHALL BE 6" (150mm) WITH 8.3" (210mm) OVERALL WIDTH AND NEUTRAL 0% BUILT IN SLOPE. CHANNELS SHALL HAVE MALE-TO-FEMALE INTERLOCKING JOINTS. GRATINGS SHALL BE DUCTILE CAST IRON FASTENED TO STEEL EDGE RAILS AND MEET THE SYSTEM LOAD CLASS SPECIFIED. CHANNELS AND GRATE SHALL WITHSTAND A REQUIRED EN1433 LOAD CLASS.

MATERIALS: PRO 150PC TRENCH DRAIN SHALL BE MANUFACTURED FROM POLYMER CONCRETE WITH THE FOLLOWING APPROXIMATE PROPERTIES:

COMPRESSIVE STRENGTH	14,000 PSI
FLEXURAL STRENGTH	4,000 PSI
TENSILE STRENGTH	1,500 PSI
WATER ABSORPTION:	0.05%
FROST PROOF:	YES
DILUTE ACID AND ALKALI RESISTANT:	YES
SALT PROOF:	YES

THE COMPLETE DRAINAGE SYSTEM SHALL BE BY VODALAND CANADA INC. ANY DEVIATION OR PARTIAL SYSTEM DESIGN AND/OR IMPROPER INSTALLATION WILL VOID ANY AND ALL WARRANTIES PROVIDED BY VODALAND CANADA INC.

REVISED: 2023

Vodaland Canada Inc.

1-5900 Ambler Dr, Mississauga, ON L4W 2N3 • Phone: 905-238-1771 • Email: info@vodaland.ca

PRO 150PC SYSTEM - LOAD CLASS D400-E600
EXPOSED ASPHALT PAVEMENT INSTALLATION

6" (150mm) PRO POLYMER CONCRETE TRENCH DRAIN

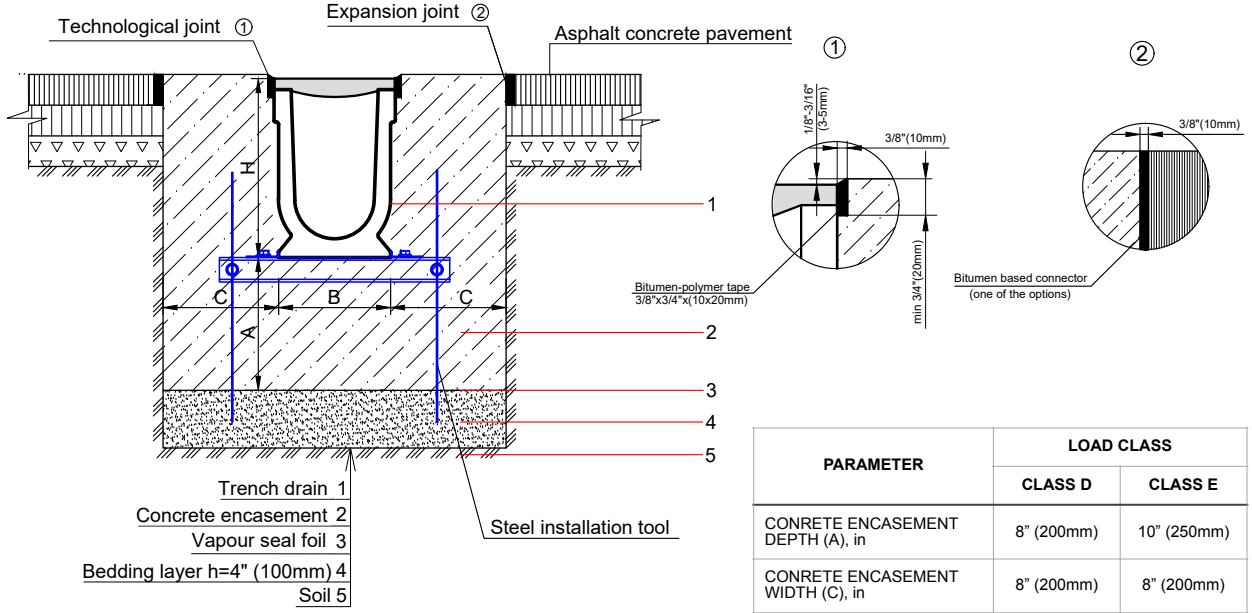

NOTES:

1. SPECIFIER IS RESPONSIBLE FOR CONCRETE ENCASEMENT AND REINFORCING BASED UPON APPLICATION AND LOCAL CODES.
2. EXPANSION AND CONTRACTION CONTROL JOINTS AND REINFORCEMENT ARE RECOMMENDED TO PROTECT CHANNEL AND CONCRETE SURROUND. ENGINEERING ADVICE MAY BE REQUIRED.
3. THIS INSTALLATION SCHEME IS A RECOMMENDATION. CONSULT WITH THE MANUFACTURER FOR INSTALLATION INSTRUCTIONS.
4. THE FINISHED LEVEL OF CONCRETE SURROUND SHOULD BE 1/8" - 3/16" (3-5mm) ABOVE THE TOP OF THE CHANNEL EDGE.

GENERAL: THE TRENCH DRAIN SHALL BE VODALAND CANADA PRO 150PC AS MANUFACTURED BY VODALAND OR APPROVED EQUAL.

SPECIFICATION: CHANNELS SHALL BE 39.4" (1000mm) LONG AND THE NOMINAL CLEAR OPENING SHALL BE 6" (150mm) WITH 8.3" (210mm) OVERALL WIDTH AND NEUTRAL 0% BUILT IN SLOPE. CHANNELS SHALL HAVE MALE-TO-FEMALE INTERLOCKING JOINTS. GRATINGS SHALL BE DUCTILE CAST IRON FASTENED TO STEEL EDGE RAILS AND MEET THE SYSTEM LOAD CLASS SPECIFIED. CHANNELS AND GRATE SHALL WITHSTAND A REQUIRED EN1433 LOAD CLASS.

MATERIALS: PRO 150PC TRENCH DRAIN SHALL BE MANUFACTURED FROM POLYMER CONCRETE WITH THE FOLLOWING APPROXIMATE PROPERTIES:

COMPRESSIVE STRENGTH	14,000 PSI
FLEXURAL STRENGTH	4,000 PSI
TENSILE STRENGTH	1,500 PSI
WATER ABSORPTION:	0.05%
FROST PROOF:	YES
DILUTE ACID AND ALKALI RESISTANT:	YES
SALT PROOF:	YES

THE COMPLETE DRAINAGE SYSTEM SHALL BE BY VODALAND CANADA INC. ANY DEVIATION OR PARTIAL SYSTEM DESIGN AND/OR IMPROPER INSTALLATION WILL VOID ANY AND ALL WARRANTIES PROVIDED BY VODALAND CANADA INC.

REVISED: 2023

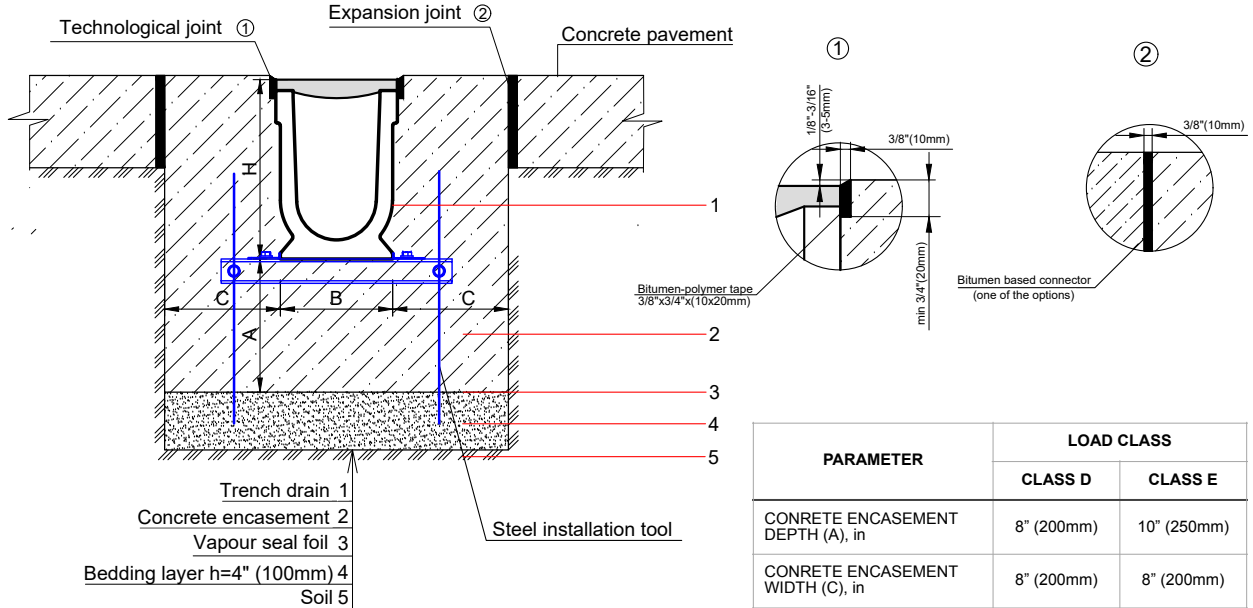
PRO 150PC SYSTEM - LOAD CLASS D400-E600
EXPOSED CONCRETE PAVEMENT INSTALLATION
6" (150mm) PRO POLYMER CONCRETE TRENCH DRAIN

PARAMETER	LOAD CLASS	
	CLASS D	CLASS E
CONCRETE ENCASEMENT DEPTH (A), in	8" (200mm)	10" (250mm)
CONCRETE ENCASEMENT WIDTH (C), in	8" (200mm)	8" (200mm)

NOTES:

1. SPECIFIER IS RESPONSIBLE FOR CONCRETE ENCASEMENT AND REINFORCING BASED UPON APPLICATION AND LOCAL CODES.
2. EXPANSION AND CONTRACTION CONTROL JOINTS AND REINFORCEMENT ARE RECOMMENDED TO PROTECT CHANNEL AND CONCRETE SURROUND. ENGINEERING ADVICE MAY BE REQUIRED.
3. THIS INSTALLATION SCHEME IS A RECOMMENDATION. CONSULT WITH THE MANUFACTURER FOR INSTALLATION INSTRUCTIONS.
4. THE FINISHED LEVEL OF CONCRETE SURROUND SHOULD BE 1/8" - 3/16" (3-5mm) ABOVE THE TOP OF THE CHANNEL EDGE.

GENERAL: THE TRENCH DRAIN SHALL BE VODALAND CANADA PRO 150PC AS MANUFACTURED BY VODALAND OR APPROVED EQUAL.

SPECIFICATION: CHANNELS SHALL BE 39.4" (1000mm) LONG AND THE NOMINAL CLEAR OPENING SHALL BE 6" (150mm) WITH 8.3" (210mm) OVERALL WIDTH AND NEUTRAL 0% BUILT IN SLOPE. CHANNELS SHALL HAVE MALE-TO-FEMALE INTERLOCKING JOINTS. GRATINGS SHALL BE DUCTILE CAST IRON FASTENED TO STEEL EDGE RAILS AND MEET THE SYSTEM LOAD CLASS SPECIFIED. CHANNELS AND GRATE SHALL WITHSTAND A REQUIRED EN1433 LOAD CLASS.

MATERIALS: PRO 150PC TRENCH DRAIN SHALL BE MANUFACTURED FROM POLYMER CONCRETE WITH THE FOLLOWING APPROXIMATE PROPERTIES:

COMPRESSIVE STRENGTH	14,000 PSI
FLEXURAL STRENGTH	4,000 PSI
TENSILE STRENGTH	1,500 PSI
WATER ABSORPTION:	0.05%
FROST PROOF:	YES
DILUTE ACID AND ALKALI RESISTANT:	YES
SALT PROOF:	YES

THE COMPLETE DRAINAGE SYSTEM SHALL BE BY VODALAND CANADA INC. ANY DEVIATION OR PARTIAL SYSTEM DESIGN AND/OR IMPROPER INSTALLATION WILL VOID ANY AND ALL WARRANTIES PROVIDED BY VODALAND CANADA INC.

REVISED: 2023
Vodaland Canada Inc.

 1-5900 Ambler Dr, Mississauga, ON L4W 2N3 • Phone: 905-238-1771 • Email: info@vodaland.ca

