

OIL WATER SEPARATOR

OILBASE100-1 OIL/WATER SEPARATOR

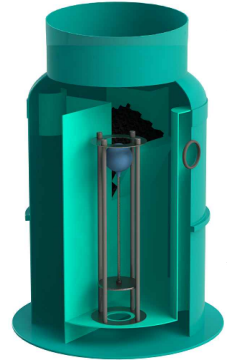
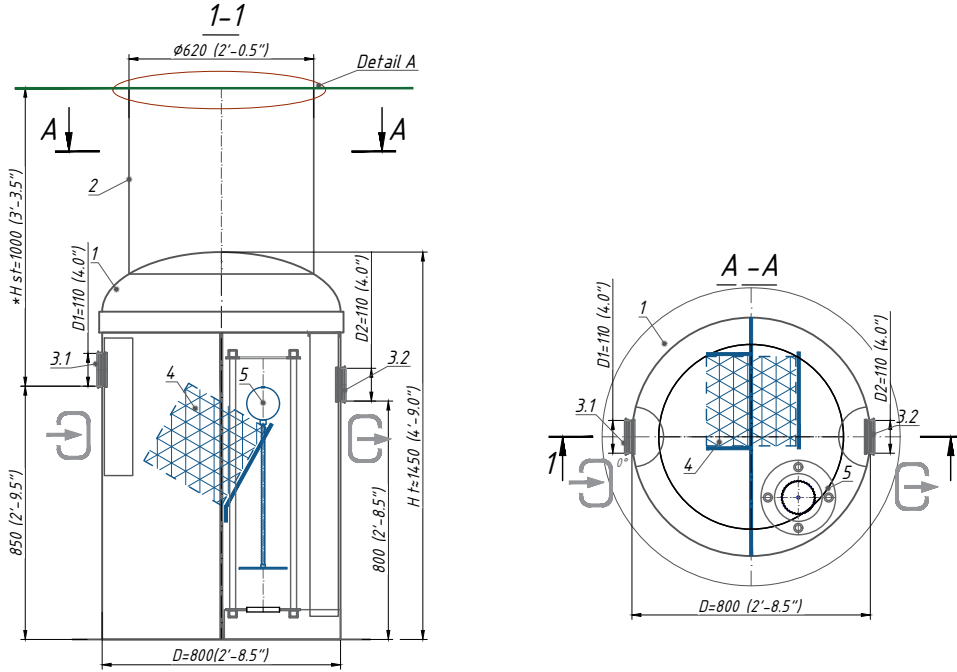

General: The oil water separator shall be Vodaland Canada OILBASE100-1 as manufactured by Vodaland or approved equal.

Specification: The oil water separator shall be manufactured from Fiberglass as per BS EN 976-1/2:1997 standard and have the following properties : Water absorption 0.01%, Frost proof, salt proof and Fuels and oils resistant. The oil separator shall be equipped with a coalescing unit and automatic shut-off valve including a sludge trap for situations when the maximum oil capacity is reached. Useful capacity of the oil separator shall be 460L (121.5 gal), a sludge capacity of 100L (26.4 gal) & light liquids capacity of 50L (13.2 gal).

Performance: The oil water separator has an efficiency of 1.456mg/L and flow rate of 1L/sec (15 GPM).

Accessories: Cover shall be manufactured from fibreglass with a minimum inside opening $\varnothing 24.5''$ (620mm) with an option of Cast iron cover. Neck extensions are available with 0.5m,1m,1.5m lengths and with or without ladders. Flange adaptors are also available to attach cast iron manhole cover. Cast Iron cover shall withstand a required EN1433 load class D.

Installation: Separator shall be installed in strict accordance with the manufacturer’s installation instructions and recommendations.

Product:

Description	Item #	Height	Width
Oilbase100-1 oil/water separator	OB1-1	72.83" (1850mm)	31.5"(800mm)

Accessories:

Description	Item #	Qty
Fiber glass adaptor plate	F0602	1
Cast Iron manhole cover - D class	35258-55M	1
Neck extension - 0.5m	N0605	1
Neck extension - 0.5m w/ 1m access ladder	N0605L15	1
Neck extension - 1.0m	N0610	1
Neck extension - 1.0m w/ 2m access ladder	N0610L20	1
Neck extension - 1.5m	N0615	1
Neck extension - 1.5m w/ 2m access ladder	N0615L25	1