

1. Dimensions for reference, inch [mm]
2. Area of water intake slots 150.4 sq in [970 sq cm]
3. Delivery and packaging are carried out in accordance with the terms of the contract
4. The manufacturer reserves the right, without notice to the consumer, to make changes to the design of the products for improvement of their technological and operational parameters, which will not affect the quality and properties of the product
5. Deviation of the actual weight of the nominal can be up to 10%.

UNLESS OTHERWISE SPECIFIED: DIMENSIONS ARE IN MILLIMETERS SURFACE FINISH: TOLERANCES: ISO 2768 - C LINEAR: ANGULAR:		FINISH:		DEBURR AND BREAK SHARP EDGES		DO NOT SCALE DRAWING		REVISION	
DRAWN		NAME		SIGNATURE		DATE		TITLE:	
CHK'D		Kozak				27.02.23		8" [DN200] Polymer Concrete Drain Channel Mega H13.2" [H335] with Cast Iron Grate E600	
APPV'D		Kyselytsia						ARTICLE:	
MFG		Malynovskiy						07500/335	
Q.A						MATERIAL: Polymer Concrete, Ductile Cast Iron		A3	
						WEIGHT: 176,9 lb / 80.4 kg		SCALE:1:5	
								SHEET 1 OF 1	

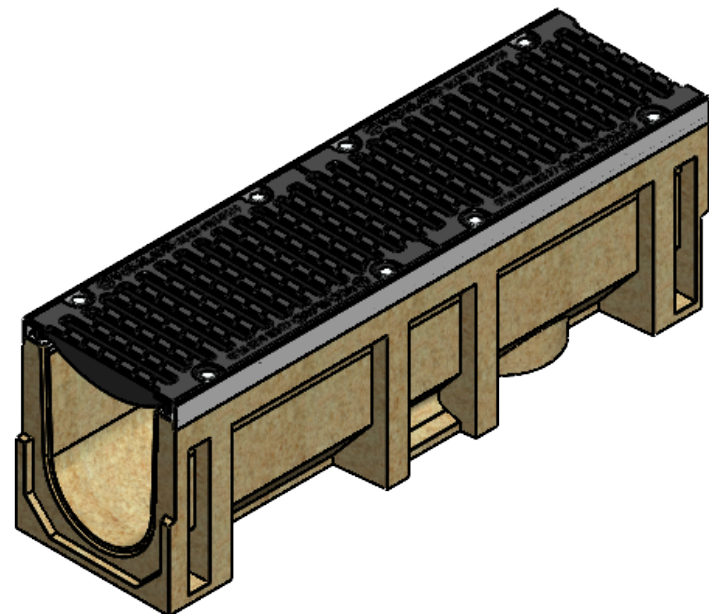
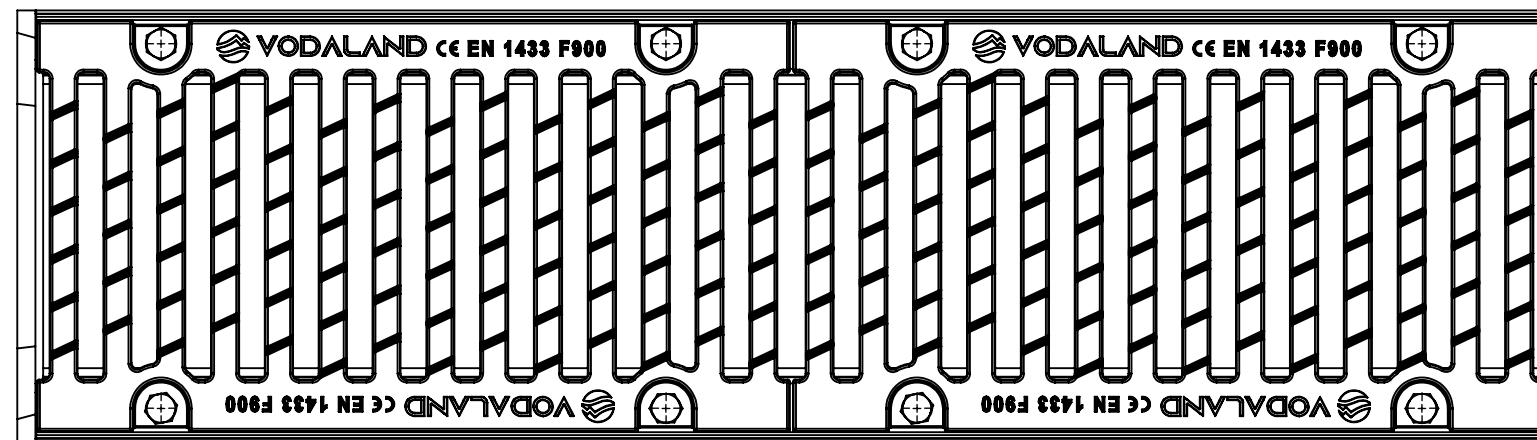
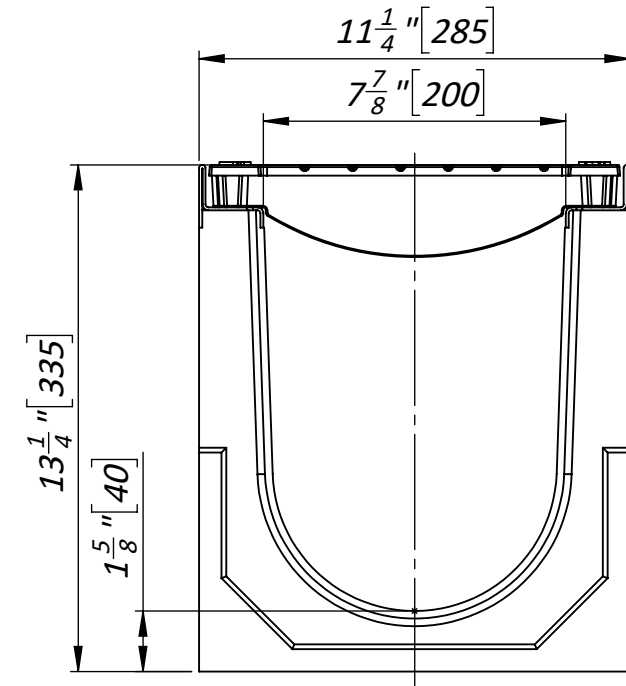
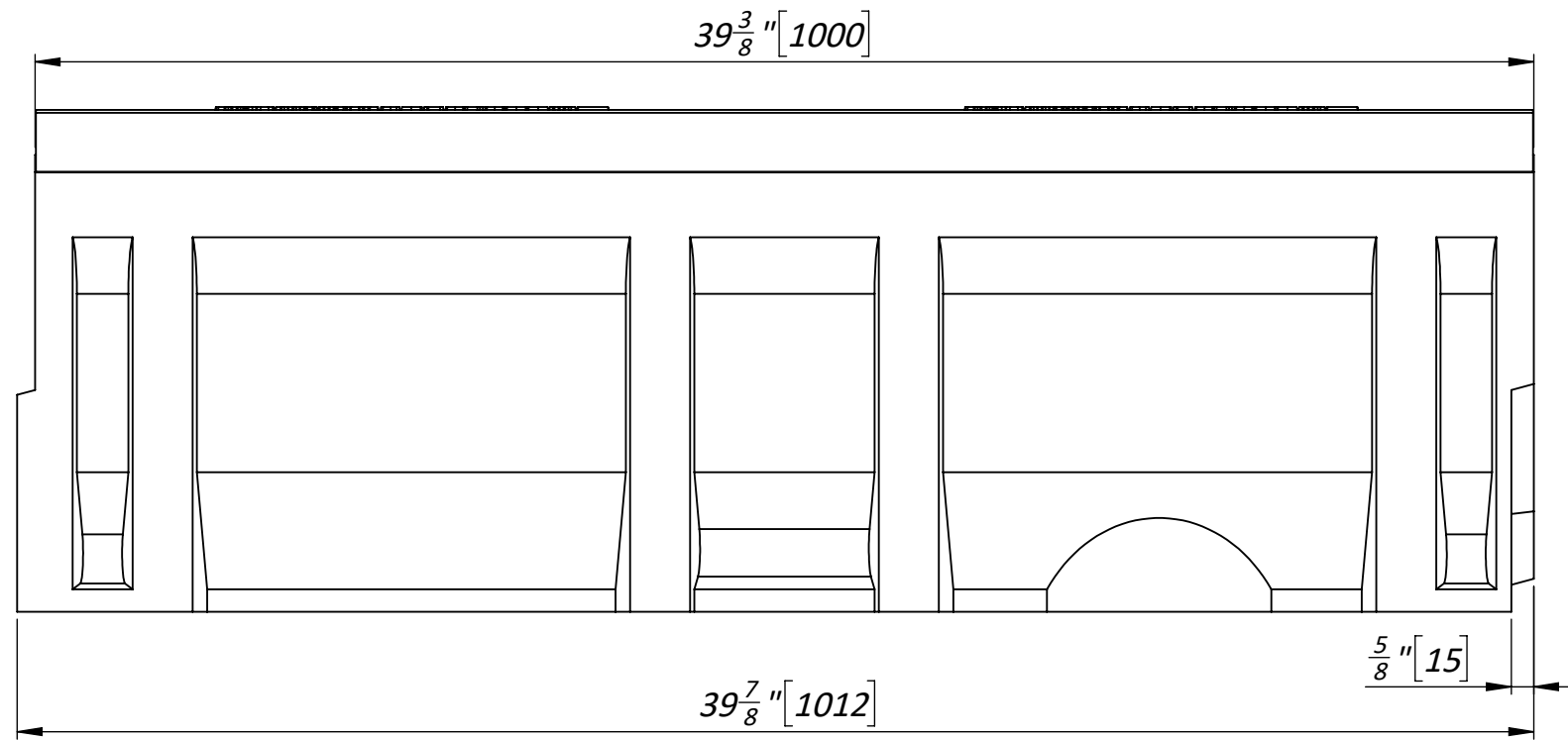

1. Dimensions for reference, inch [mm]
2. Area of water intake slots 150.4 sq in [970 sq cm]
3. Delivery and packaging are carried out in accordance with the terms of the contract
4. The manufacturer reserves the right, without notice to the consumer, to make changes to the design of the products for improvement of their technological and operational parameters, which will not affect the quality and properties of the product
5. Deviation of the actual weight of the nominal can be up to 10%.

UNLESS OTHERWISE SPECIFIED: DIMENSIONS ARE IN MILLIMETERS SURFACE FINISH: TOLERANCES: ISO 2768 - C LINEAR: ANGULAR:			FINISH:		DEBURR AND BREAK SHARP EDGES		DO NOT SCALE DRAWING		REVISION		
DRAWN			NAME		SIGNATURE		DATE		TITLE:		
CHK'D			Kozak				27.02.23		8" [DN200] Polymer Concrete Drain Channel Mega H13.2" [H335] with Cast Iron Grate F900		
APPV'D			Kyselytsia						ARTICLE:		
MFG			Malynovskiy						07501/335		
Q.A									A3		
							MATERIAL: Polymer Concrete, Ductile Cast Iron		SCALE:1:5		
							WEIGHT: 190,7 lb / 86.7 kg		SHEET 1 OF 1		