

MANHOLE COVER - LOAD CLASS D400

CAST IRON MANHOLE COVER

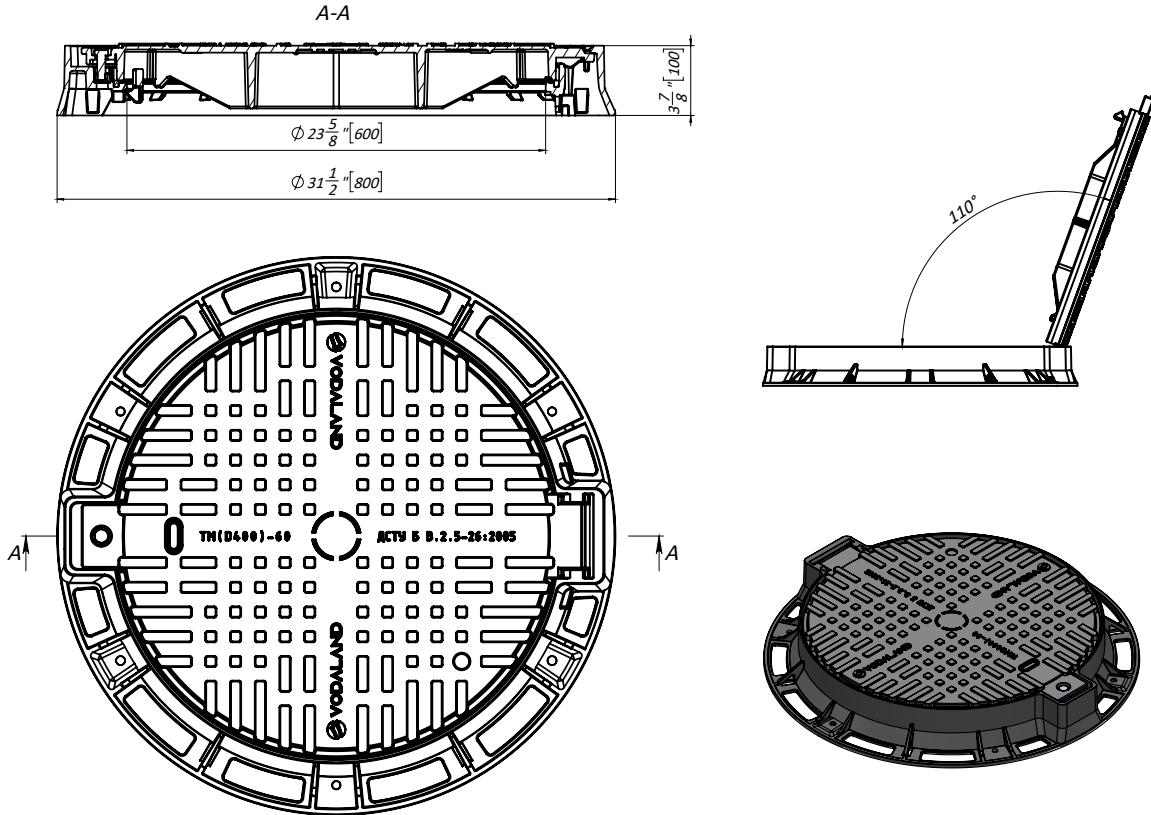

General: The manhole cover shall be Vodaland Canada Cast-Iron Manhole cover as manufactured by Vodaland or approved equal.

Specification: Manhole cover shall be round Ø31.5" (800mm) external, Ø24" (600mm) internal and 4" (102mm) deep. Cast Iron Manhole cover shall be manufactured from high quality of cast iron with anti corrosion features. Manhole cover exhibits a range of motion up to 110 degrees, facilitating unhindered access to internal components for maintenance or inspection purposes. The cover, when pivoted between 20-30 degrees allows for seamless disengagement without compromising structural integrity. Cast Iron Manhole shall withstand a required EN1433 load class.

Name	Article	H, in	H, mm	Load Class
Cast Iron Manhole cover	35258-55M	4	102	D400