

8 7 6 5 4 3 2 1

F  
E  
D  
C  
B  
A

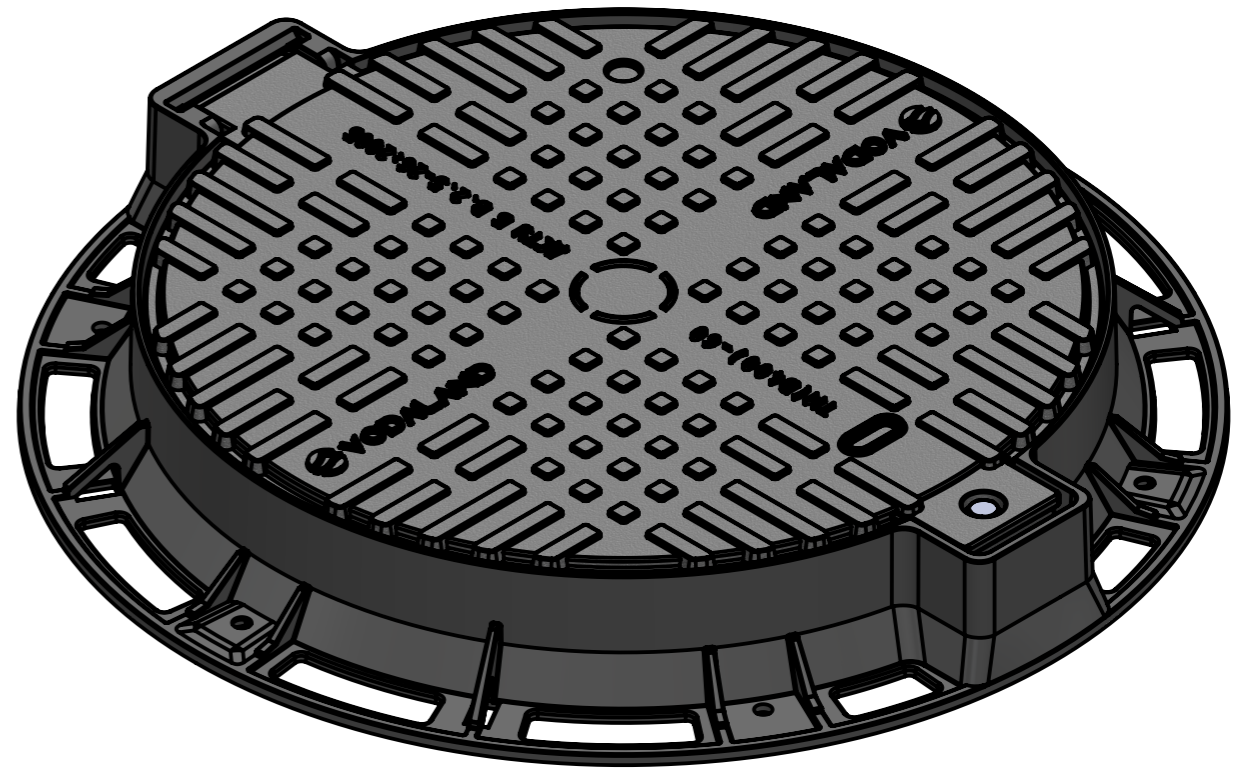
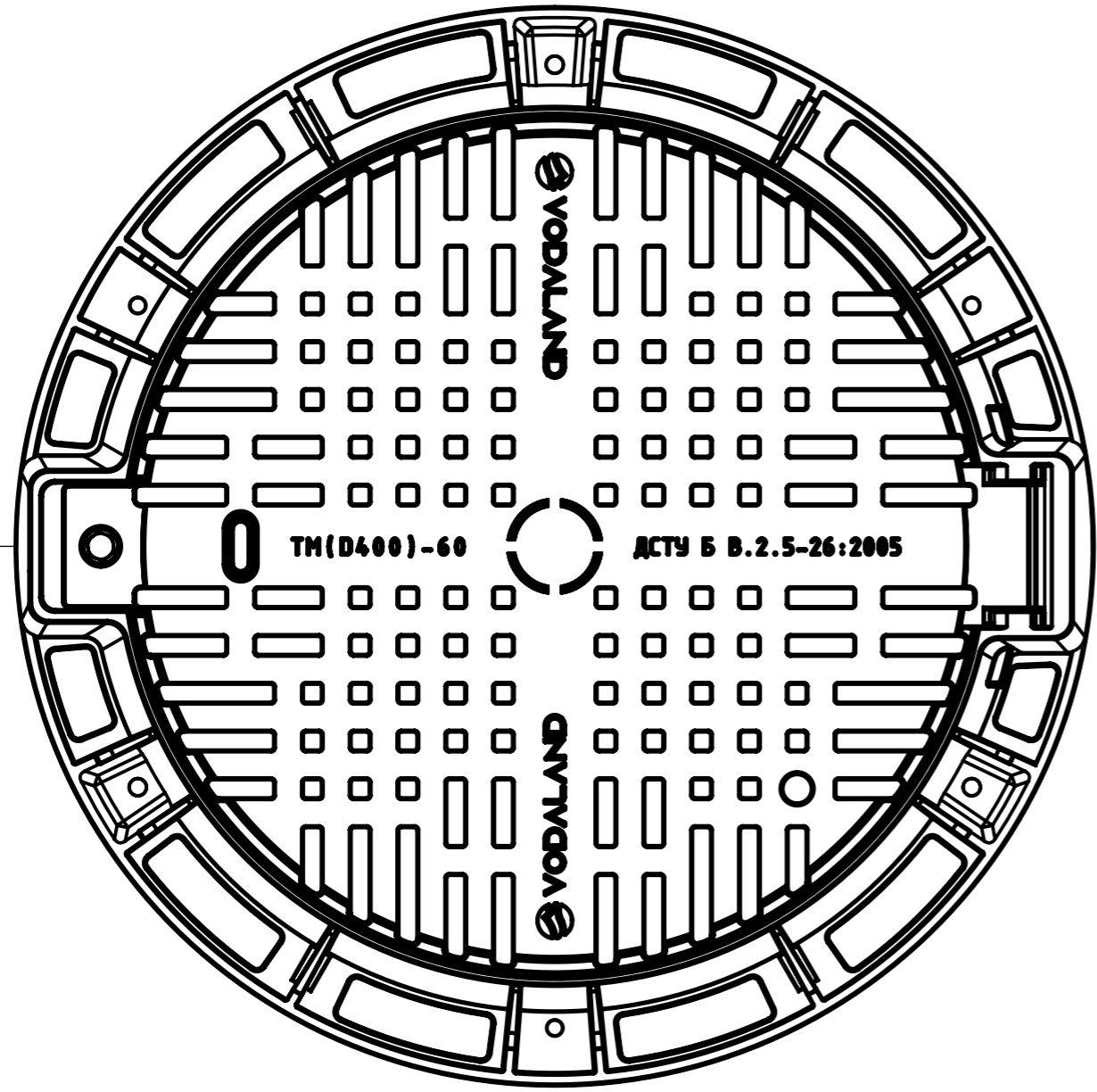
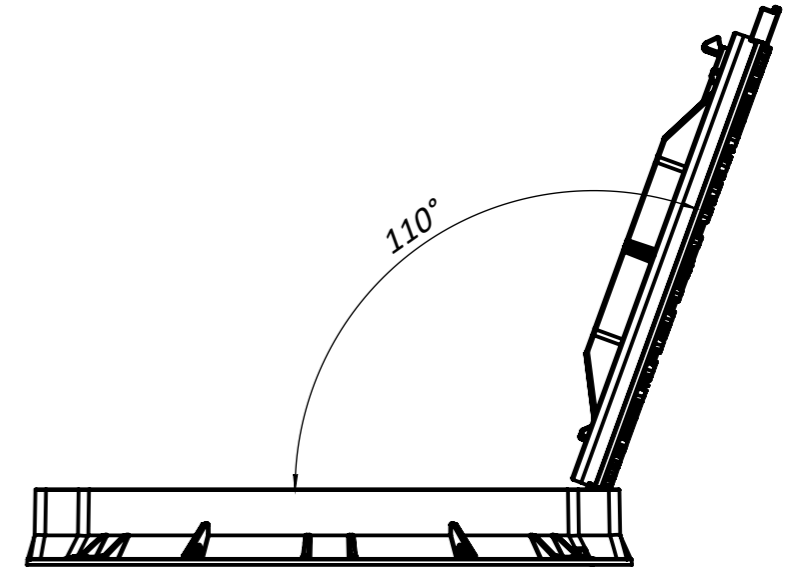
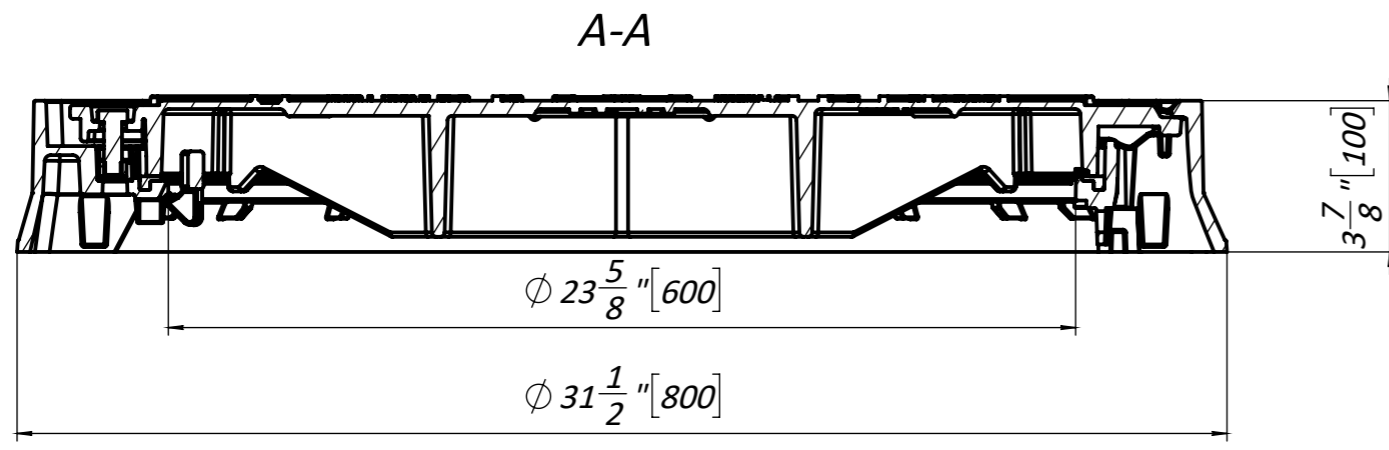

- 1. Deviation of the actual weight of the nominal can be up to 10%
- 2. Dimensions for reference inch, [mm]

UNLESS OTHERWISE SPECIFIED: DIMENSIONS ARE IN MILLIMETERS SURFACE FINISH: TOLERANCES: ISO 2768-c LINEAR: ANGULAR:			FINISH:		DO NOT SCALE DRAWING		REVISION	
DRAWN: LMV			SIGNATURE:		DATE: 15.06.23		TITLE:	
CHK'D: LMK			SIGNATURE:		DATE:		24" Cast iron manhole D32" round heavy magistral with a lock D400	
APPV'D:			SIGNATURE:		DATE:		Load class: D400	
MFG:			SIGNATURE:		DATE:		ARTICLE:	
Q.A:			SIGNATURE:		DATE:		35258-55M	
			MATERIAL:		Cast iron		A3	
			WEIGHT:		113,91 lb / 51,67 kg		SCALE: 1:5	
							SHEET 1 OF 1	

8 7 6 5 4 3 2 1