

# MAGNUSON

## SUPERCHARGERS

Installation Instructions for:  
**INTERCOOLED SUPERCHARGER SYSTEM**  
Magnum HEMI Car



Step-by-step instructions for installing the best in supercharger systems.

**\* PREMIUM GASOLINE FUEL REQUIRED \***

**ATTENTION!**

**Your MAGNUSON SUPERCHARGER kit is sensitive to corrosion!**

**Use only the vehicle manufacturer recommended coolant for your engine in the intercooler system as well.**



Magnuson Superchargers  
1990 Knoll Drive, Bldg A, Ventura, CA. 93003  
(805) 642-8833  
[magnusonsuperchargers.com](http://magnusonsuperchargers.com)

# INSTALLATION MANUAL

## Magnuson Superchargers 5.7L, 6.1L and 6.4L HEMI Engine Challenger, Charger, and Chrysler 300

Please take a few moments to review this manual thoroughly before you begin work: Make a quick parts check to make certain your kit is complete (see shipper parts list in this package). If you discover shipping damage or shortage, please call our office immediately. Take a look at exactly what you are going to need in terms of tools, time, and experience. Review our limited warranty with care. When unpacking the supercharger kit **DO NOT** lift the supercharger assembly by the black plastic bypass actuator. This is pre-set from the factory and can be altered if used as a lifting point!

Caution: Relieve the fuel system pressure before servicing fuel system components in order to reduce the risk of fire and personal injury. After relieving the system pressure, a small amount of fuel may be released when servicing the fuel lines or connections. In order to reduce the risk of personal injury, cover the regulator and fuel line fittings with a shop towel before disconnecting. This will catch any fuel that may leak out. Place the towel in an approved container when the job is complete.

**NOTE: This supercharger system requires the use of only premium gasoline fuel, 91 octane or better. It is NOT compatible with E85, Ethanol, or Flex fuels.**

Magnuson Superchargers recommend that you run a minimum of one (1) tank of premium fuel through your vehicle prior to installation of the system to prevent any possible damage that may occur due to running the supercharged engine on lower octane fuel. **DO NOT add octane booster to your vehicle.**

Our Magnuson Supercharger kits are designed for engines in good mechanical condition only. Installation on high mileage or damaged engines is not recommended and may result in engine failure, for which we are not responsible. Magnuson Superchargers is not responsible for the engine or consequential damages.

**Magnuson Superchargers kits are designed for use on stock vehicles. To that end, the alteration or modification of the fuel system, drive train, engine, and/or supercharger outside of stock parameters in any way can result in engine damage or failure for which Magnuson Superchargers is NOT responsible and will void Magnuson Superchargers warranty and CARB certification. Aftermarket engine recalibration devices that modify fuel and spark curve (including, but not limited to programmers) are not recommended and may cause engine damage or failure. Use of non-Magnuson Superchargers approved programming will void all warranties. If you have any questions, call us.**

A new fuel filter is recommended at the time of supercharger installation

Stock spark plugs and stock plug gap is recommended

Drive belt = Gates # K061010 for 2013+ cars and K061020 for Pre-2013 cars

### Tools Required:

Metric wrench set

¼" - 3/8" and ½" drive metric socket set (Standard & Deep)

3/8" and ½" drive foot pound and inch pound torque wrenches

Phillips and flat head screwdrivers

Small or angled 3/8" drill motor

Drain pan

Hose cutters

Hose clamp pliers

Safety glasses

Metric Allen socket set 3/8" drive

Shop vacuum cleaner

Blue Loctite 242

Right Angle drill for pinning crank pulley

Helpful Tool: Air or electric impact wrench.

### Contact information:

Magnuson Superchargers

1990 Knoll Drive, Bldg A

Ventura, CA 93003

Tech Support: support@magnusonsuperchargers.com

Sales: sales@magnusonsuperchargers.com

Website: www.magnusonsuperchargers.com

1. **NOTE: 2015+ vehicles remove the PCM from the RH side of the cowl and send to HP Tuners for Unlock. This process will be shown in detail later. 2018+ vehicles need to have the security bypass cable installed, which will also be shown in detail later. If your kit has a provided handheld tuner follow the instructions in the provided pamphlet to install your tune. Your handheld tuner may not match the one shown.**



2. Your Intercooler system is sensitive to corrosion. It's very important to use the OEM recommended coolant mixture in your supercharger system as well.



3. Your system requires the use of a minimum 91 Octane gasoline fuel. This system is **not** compatible with E85 fuel.

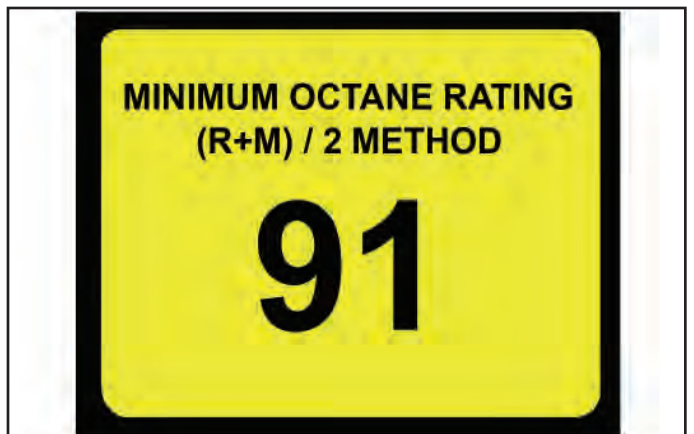

**Any future reference to the left or right hand side of the vehicle is from a drivers seat perspective looking forward.**

4. In the trunk of the vehicle, below the lift up panel is the vehicle battery. Disconnect the battery negative (-) cable at the terminal using a 10mm wrench and set it aside where it will not accidentally make connection with the battery post. You can use a rag to insulate the connection.



5. **2015+ M.Y. Vehicles ONLY PCM Removal Process.**

2015-up M.Y. vehicles must have the PCM sent out to be reworked. The following process describes how to access the PCM. Using a small screwdriver, gently remove the caps at the base of the wiper arms.



6. Using a 15mm socket, remove the nuts that secure both wiper arms to the posts.



7. Rock the wiper arms to remove them from the stud.



8. Gently remove the fir tree connectors from the top corners of both sides of the cowl.

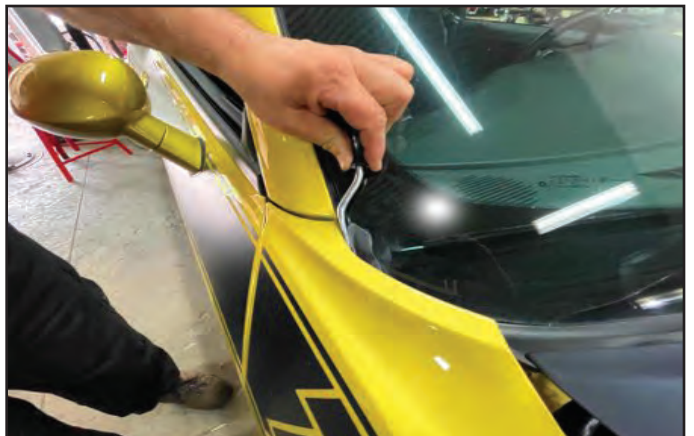

9. Remove the fir tree connector securing the rubber hood isolators on both sides of the cowl.



10. Remove the right hand side cowl access panel by lifting up on the tab.



11. Remove the left hand side cowl panel access panel by lifting up on the tab at the arrow.



12. Working from one side of the cowl to the other, remove all the push pins and fir tree connectors that secure the cowl to the vehicle.

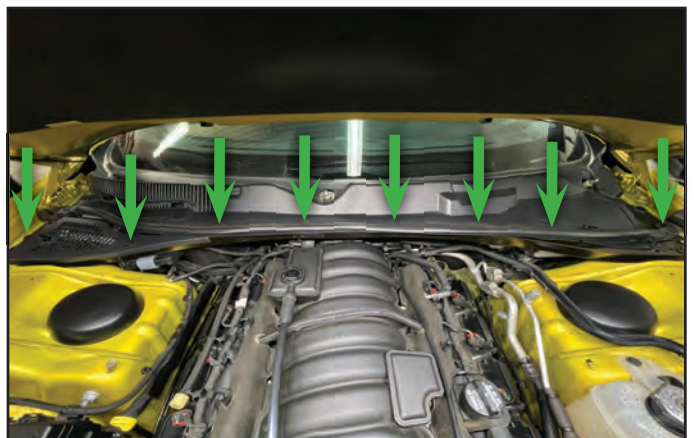

13. Lift up on the cowl and pull it forward to remove it from the vehicle.



14. Remove the fastener securing the PCM to the vehicle at the red circle.

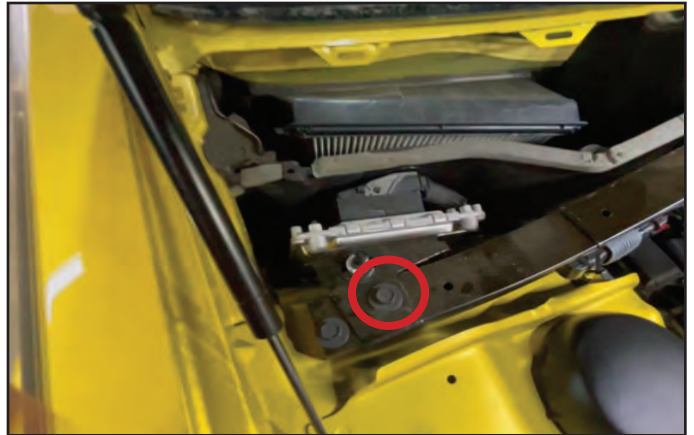

15. Lift the PCM up and out of its mounting location. Depress the locking tabs and cycle both connectors to remove them from the PCM.

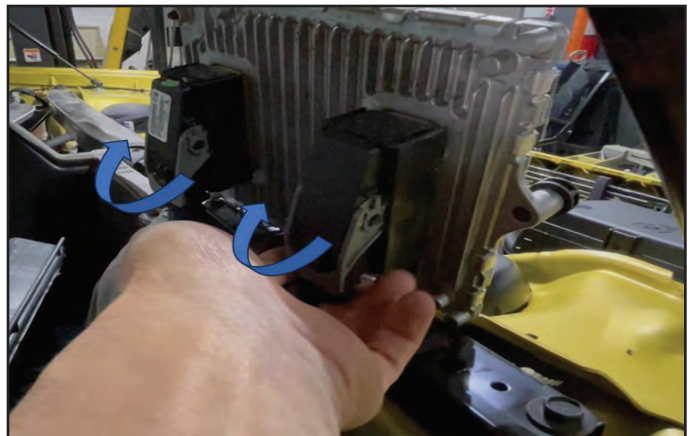

16. Using a small screwdriver, gently lift the locking tab on the electrical connector at the hood sensor. Disconnect it from the sensor.



17. Take the PCM to a work bench and remove the (2) nuts that secure it to the bracket. Carefully package the PCM and ship it out to be updated as per the instruction.

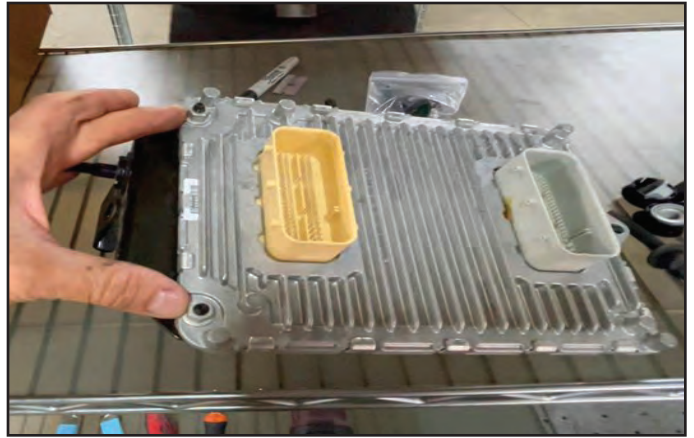

18. **2018+ Vehicles Only Security Bypass Cable Installation**

The following slides detail installation of the security bypass cable required for PCM programming on 2018+ vehicles.

**Note: the cable is only required for programming; it can be installed and routed under the dash permanently or removed after the PCM has been updated.**



19. Looking up from the passenger side foot well, remove 3 push pins circled in red holding the cover plate to the underside of the dash.

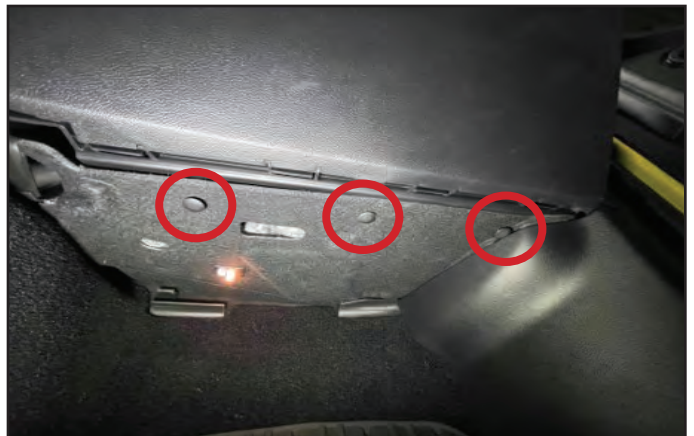

20. Hinge the cover plate down to provide access to the underside of the dash. Locate the factory CAN-BUS connector in the encircled area. Plug the small white connector from the supplied cable into the factory CAN-BUS system in any open port.



21. If you prefer to leave the security bypass cable (highlighted in green) permanently installed, route the other end under the dash and over to the factory OBDII port in the driver's foot well. Plug the cable into the OBDII port ensuring it is fully seated. Follow the instructions to program the PCM using the hand-held device after the supercharger kit has been installed.

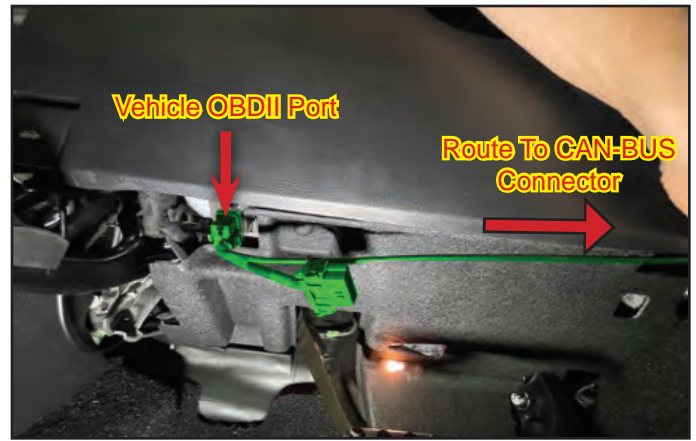

22. Reinstall the trim panel under the passenger side of the dash, securing it with the fir tree connectors.



23. Slowly remove the gas cap to release fuel system pressure. Also at this time affix the Premium Fuel Only sticker to the door of your gas fill cap at the arrow location.



24. Remove the splash shields below and behind the nose fascia. There are two main components, with nine plastic push pin rivets, and four 10mm headed bolts.





25. Start removing the push pin rivets by prying out on the center spreader and then pull the rivets free. There are 3 push pin rivets on the driver's side and 4 on the passenger side. Now remove the two 10mm headed bolts joining the two main components together. Next remove the two rear 10mm headed bolts from the back splash shield.

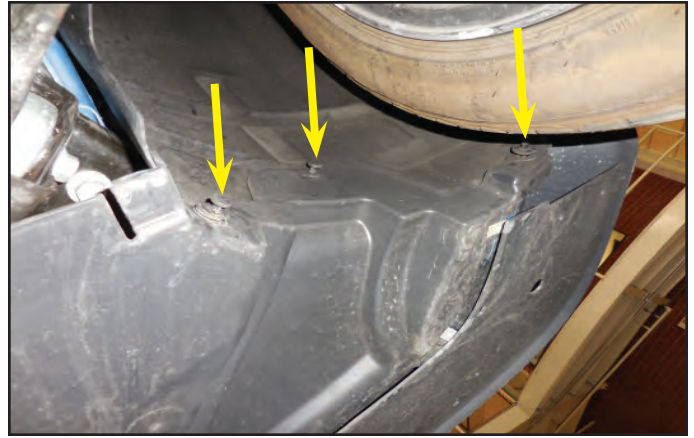

26. Pull the rear splash shield out of the vehicle and set aside for later re-installation.



27. Remove the 2 T15 Torx (or 8mm hex) bolts from the front splitter (One per side).



28. Remove the seven 7mm bolts from the front of the splash shield where it joins the spoiler.



29. Pull the front splash shield from the vehicle. Set aside for re-installation at a later time.



30. Pull up on the two halves of the radiator cover to unsnap them from their mounting holes and set aside for later re-installation.

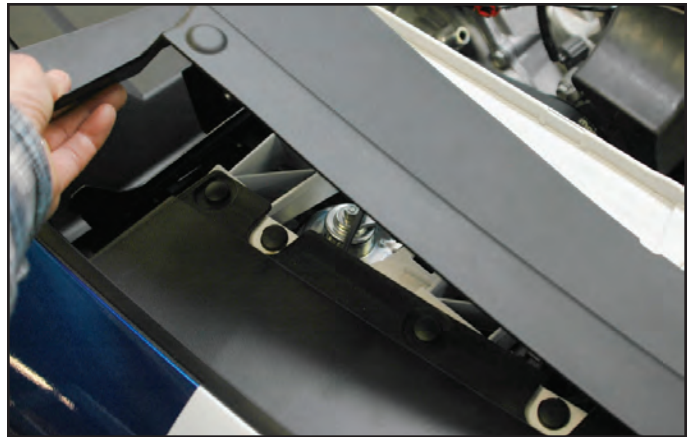

31. While you are below the vehicle, on the right side there is a main harness connector that spreads down to connect to the fog lights, corner markers, etc. Disconnect the plug tying the harness to the harness of the fascia/grille. **On 2021 vehicles there is no main harness connector. You must disconnect (3) harness takeouts for marker light, washer pump and washer low fluid switch.**



32. Remove the forward 3 push-pin rivets holding the wheel well shroud to the fender on each side of the vehicle by prying out the center pin and then pull the push rivets out.



33. Once the rivets are out, pull back on the wheel well shroud to expose the bolt by the junction of the fender and the fascia and use a 10 mm wrench to remove the bolt on each side of the vehicle.

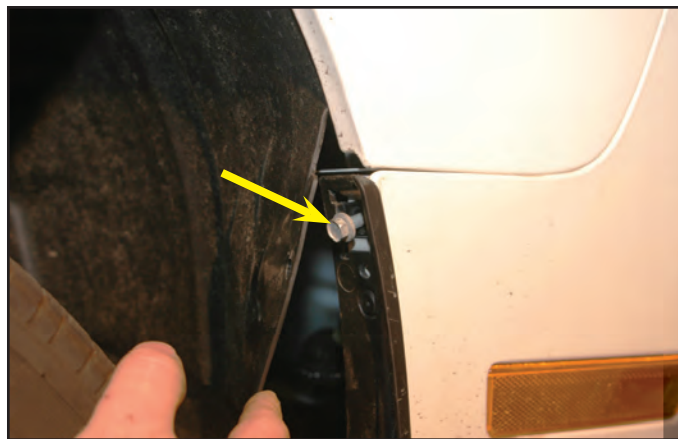

34. Using a 10 mm socket remove the bolt on each side of the fascia midway up. It is easiest to reach it from the bottom side of the vehicle. (Fascia shown off vehicle for bolt location clarity)



35. Carefully but firmly pull outward on the fascia near the side reflector to disengage the plastic mounting clips on each side of the vehicle.



36. From the top of the vehicle, where the corner of the fender by the hood attaches to the fascia with a 10mm nut on the fascia mounted stud loosen this nut/washer and remove from each side of the vehicle.

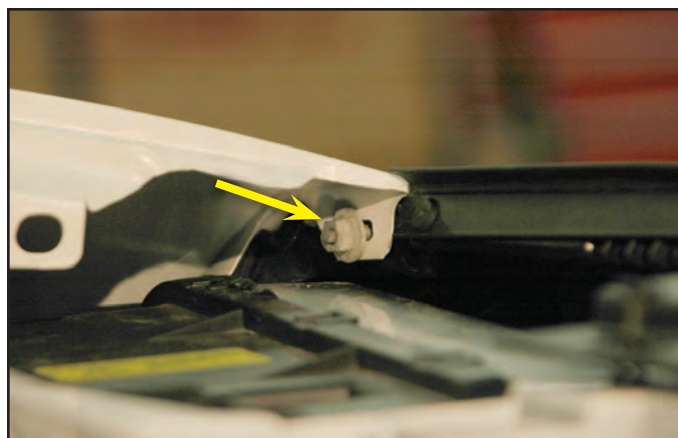

37. Six push pin rivets attach the top of the fascia to the frame support, pry out the center of the push pin which allows the rivets to be pulled free. Carefully pull the fascia/grill forward to remove from vehicle. There is a plastic guide pin that slides into the fender flange on each side. It helps to have an assistant and pull from the sides to allow the guide pins slide out more easily. Verify that your electrical connection is disconnected and set the fascia/grille aside in a safe place.



38. Remove the three push pin rivets holding the plastic bumper section to the sub frame. (2 locations shown)

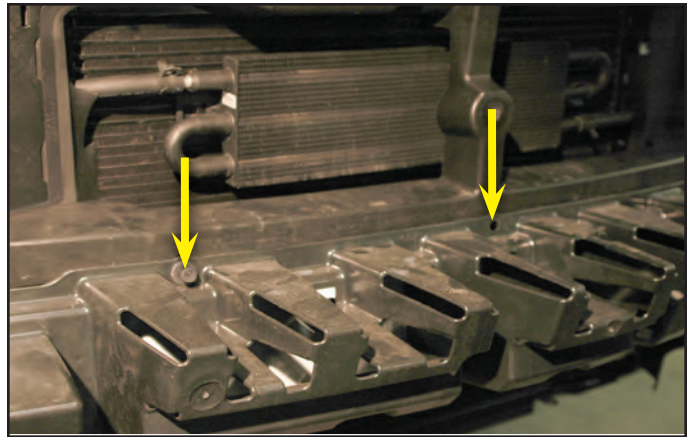

39. The remaining eight clips holding the plastic bumper section to the sub frame can be released using a flathead screwdriver to depress the locking tab.

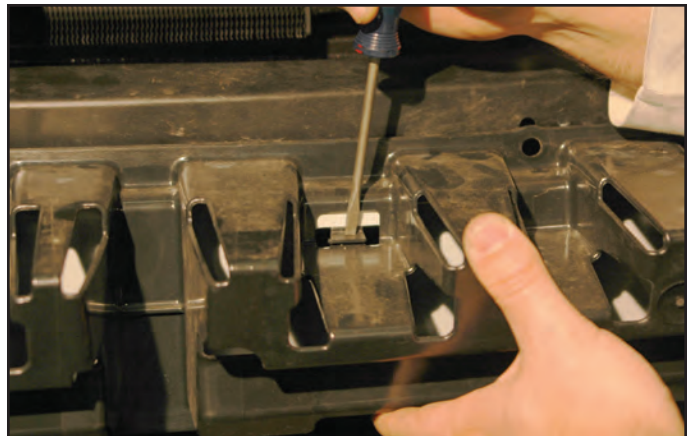

40. Once the clips are released, pull the plastic bumper section free and set aside for installation later.



41. Pull out the center post of the plastic push pin rivets and remove the 4 rivets shown here.



42. Disconnect and remove the ambient air temperature sensor harness from the closeout panel.

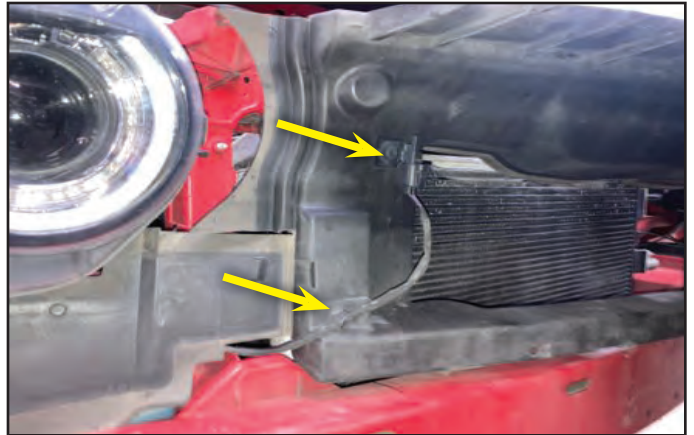

43. Remove the plastic grille fascia support and set aside for re-installation later.



44. **For vehicles with hydraulic power steering:** The power steering cooler is held to the upper section of the AC condenser with two plastic clamps. Release the clamps by depressing the locking tabs behind the tube and pull the power steering cooler off the mounting tabs.



45. **For vehicles with hydraulic power steering:** On the right side of the vehicle the hose from the power steering condenser must be pulled off the mounting tab to allow the cooler to be moved forward.

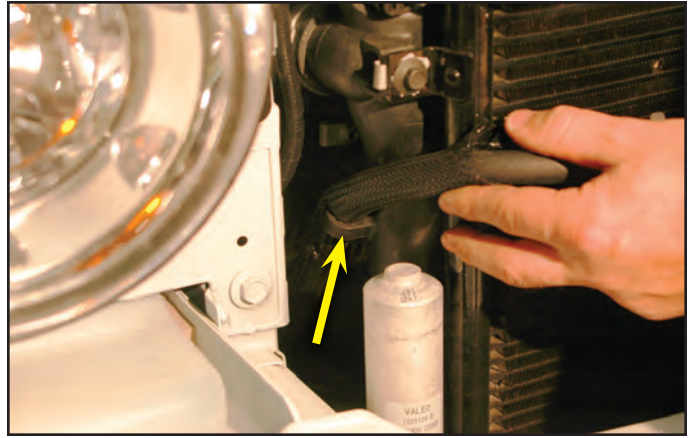

46. **For vehicles with hydraulic power steering:** Use a saw, or cutting wheel to remove the locking tab from the face of the power steering mounting bracket. Be careful to not damage the AC condenser.



47. **Ensure that the engine has had time to cool before draining the coolant.** Open the drain valve on the bottom of the passenger side radiator. Collect the drained fluid in a clean pan and set aside for later re-use.

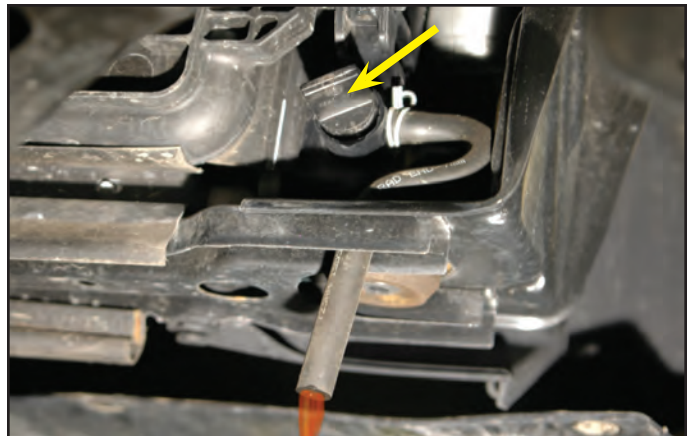

48. Remove the radiator fill cap to relieve back pressure and facilitate drainage.



49. Pull up firmly on the engine cover and set aside. This will not be re-used but should you wish to return to stock condition you may want to save the parts removed. **Note: 6.4L engines will have a cover on both valve covers, which pull off in the same manner as shown in the next step.**



50. Remove the two engine covers shown if you have a 6.4L engine.



51. Unplug the IAT from the intake air tube. **Note: If equipped with a PCV fresh air line running to the airbox, disconnect it now.**



52. Remove the mounting bolt for the air box shown with the green arrow, and the hose clamp on the intake air tube at the yellow arrow location using an 8mm wrench. Remove the intake air tube and air box from the vehicle, set aside for some parts that will be reused later.



53. Unplug the Electronic Throttle Control (ETC) from the throttle body. Pull back on the white locking tab first before you unplug this connector.



54. Unplug the eight fuel injector connections. You will need to pull out on the red locking tab to disengage it first. Then you can push on the black side button as you pull it out.



55. On the very back of the OEM intake manifold on the passenger side is the MAP sensor. Disconnect this plug and the mounting push pin clip as well.



56. Disconnect the EVAP hose from the front of the driver side of the intake manifold behind the throttle body. Pull the EVAP hose clips off from along the manifold.





57. Disconnect the PCV vent hose from the air box and the oil fill spout extrusion.

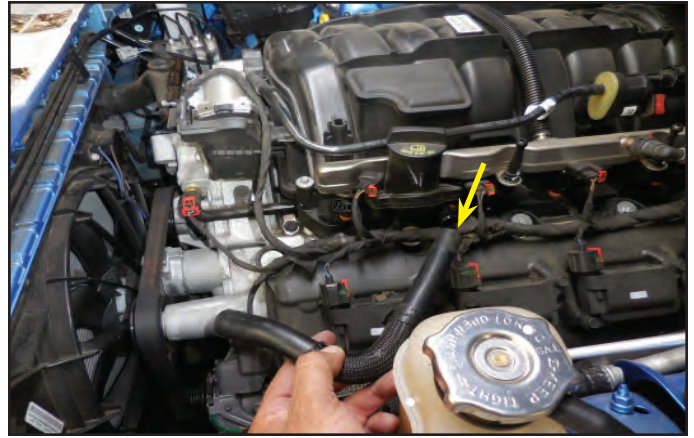

58. **CAUTION: Fuel line may hold residual pressure. Wear safety glasses to protect your eyes. Use shop towels to capture any residual fuel and dispose of it properly.** Remove the fuel line from the fuel manifold on the driver side. **For earlier models** you will press on the blue tabs of the fuel line locking clip and then pull the line free. For late models see the step below.

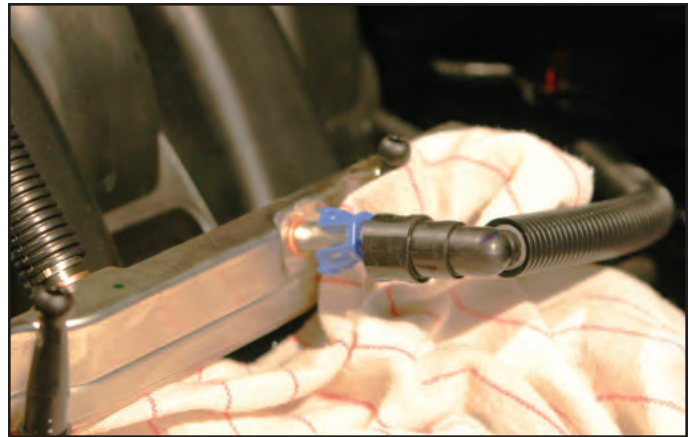

59. **For newer model Challengers** pull on the red locking tab of the fuel line locking clip shown at the yellow arrow location and then push in the black button shown with the green arrow on the left side of the connector and pull the line free. Use shop towels to capture any residual fuel and dispose of them properly. **It's a good idea to plug the end of the fuel line and cap the fuel line barb on the fuel rail.**



60. Remove the ten bolts holding the intake manifold to the heads with an 8mm socket wrench.



61. Pull the OEM intake manifold forward a bit to gain access to the brake booster hose plugged into the back of the manifold. Disconnect this hose from the rear of the intake manifold. There is also a wire loom clamp located at the back of the intake manifold that needs to be pulled free or cut off.



62. Carefully lift the OEM intake assembly from the vehicle.



63. Remove the foam dampening pad from the valley cover if applicable. This will not be reused.



64. Use a vacuum to remove any debris from the heads and adjacent surfaces. Be careful to not allow any debris into the open ports.



65. Wipe the port surfaces clean using a shop rag and alcohol (lacquer thinner, acetone or some other non-petroleum based solvent).

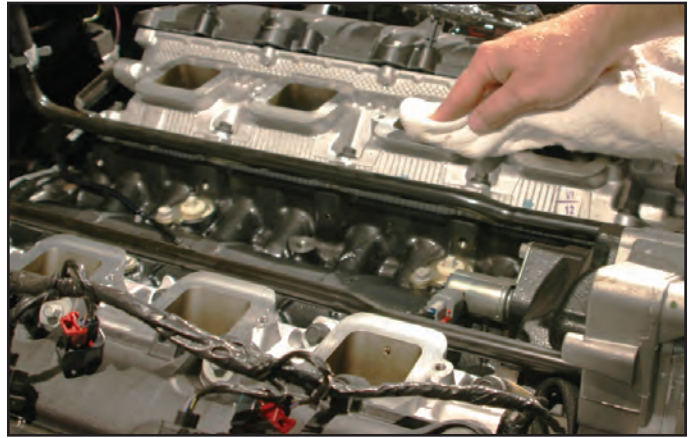

66. Use tape or shop rags to cover the exposed ports and prevent debris from entering the ports.



67. Use a 16mm wrench to remove the air box extension support bracket if applicable. Not required on 6.4L vehicles.



68. To facilitate the hose install, use a long 3/8" drive ratchet to spring the tensioner and remove the OEM fan belt. This belt will not be reused.



69. Disconnect the fan electrical power connection on the passenger side of the fan shroud assembly.

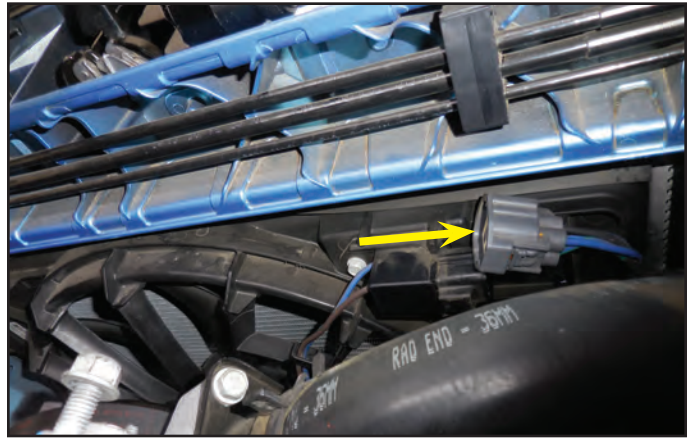

70. Use an 8mm wrench to remove the two fan shroud mounting bolts, there is one bolt on each side of the shroud.



71. Remove the fan shroud from the bottom. The assembly will be reused. **NOTE: Loosen the 4 (13mm socket) bolts holding the lower radiator bracket to the frame. Remove 1 bolt on each side. This will allow room for the shroud to be removed.**



72. Place the two provided dowels in two of the existing crank pulley ring holes.



73. Use a pry-bar or long heavy duty screwdriver to anchor the pulley using alternate sides of the dowels you pushed in the pulley holes as shown. This will give you a lever to stop the pulley from turning. Now, use a 21mm wrench to remove the crank harmonic balancer pulley bolt. Set aside for later use along with the two provided dowels.



74. Install the crank pin drill guide with the provided bolt and a 22mm wrench. It's convenient to align the two holes for the crank pins in the drill guide horizontally for ease of access. **Torque the temporary bolt holding the drill guide to 40 ft-lbs.**



**Wear safety glasses for the drilling, reaming and compressed air steps.**

75. Use the provided drill bit to drill the two holes using the pin guide holes. Before beginning, inspect the drill bit: You will notice there are two small 'steps' in the diameter of the bit. The second step, closest to the shank is your stopping point at the drill guide. If you put a piece of tape around the high point of that step you will have a visible stopping point as it touches the drill guide. Be sure to drill the holes completely to the second step of the drill bit.



76. Blow out the holes using compressed air. Use safety glasses and be careful of your eyes!



77. Install the provided reaming bit into the drill motor and ream the holes you just made out.

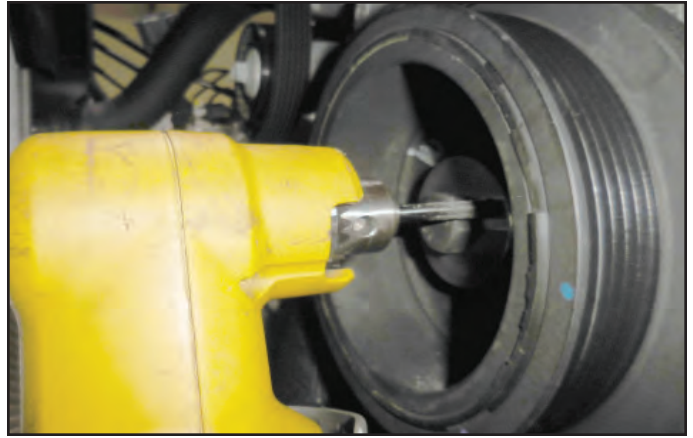

78. When you're finished with the ream bit, blow the holes out again with compressed air watching out for your eyes.



79. Remove the drill guide kit using a 22mm wrench.



80. Gather the two provided crank pins.



81. Put a generous bead of provided green Loctite 680 on the pins and press one into each of the two holes you just prepared.



82. Use a hammer and drift-pin or nail-set to tap the crank pins in completely. Ensure that they are in completely, and will not touch the surface of the crank bolt directly when installed.



83. **Re-install the removed OEM crank bolt and torque to 129 ft-lbs.** Verify your torque wrench settings. Use the two supplied dowels in two of the pulley face holes again as an anchor, and a 22mm wrench to tighten the pulley bolt.



84. Re-install the OEM fan shroud assembly in the vehicle. We found this a little easier from below the vehicle.



85. Anchor the fan shroud in place using the two OEM mounting bolts.

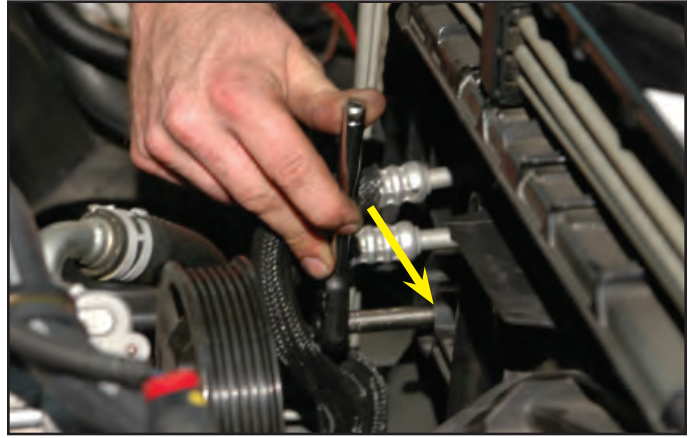

86. Re-connect the fan control plug.



87. Clean up the end cap surfaces of the heat exchanger using acetone or lacquer thinner. Cut the supplied sticky backed foam strip to fit the length of the end caps and attach to the inside surface of the end cap as shown.

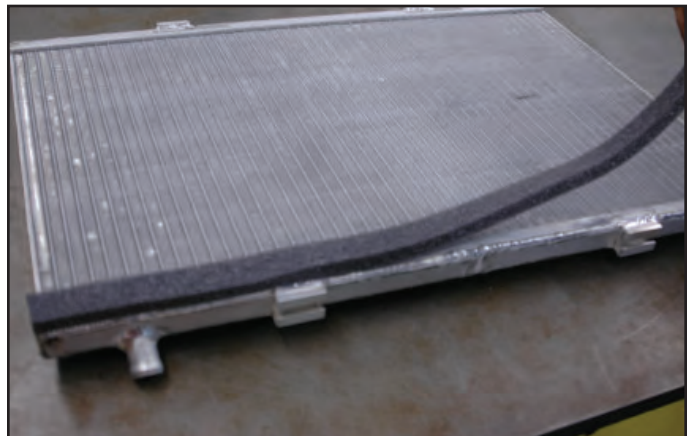

88. Cut the adhesive backed rubber strips and affix to the inside surface of two of the supplied heat exchanger mounting hooks. Apply a strip of the adhesive backed foam to the remaining heat exchanger mounting hook.

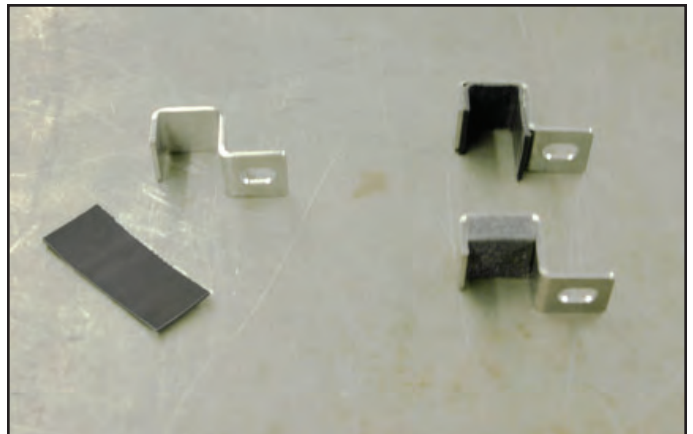



89. Insert two of the supplied carriage bolts in the slots on the top of the heat exchanger for attaching the mounting hooks. Here is a close-up of one location.

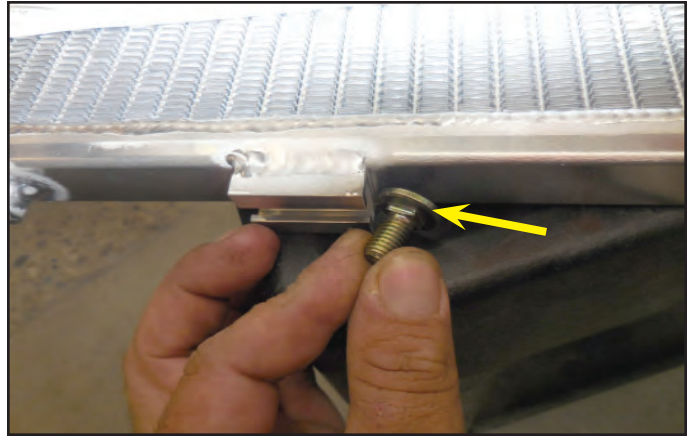

90. The two locations for the carriage bolts are shown here at the arrow locations.

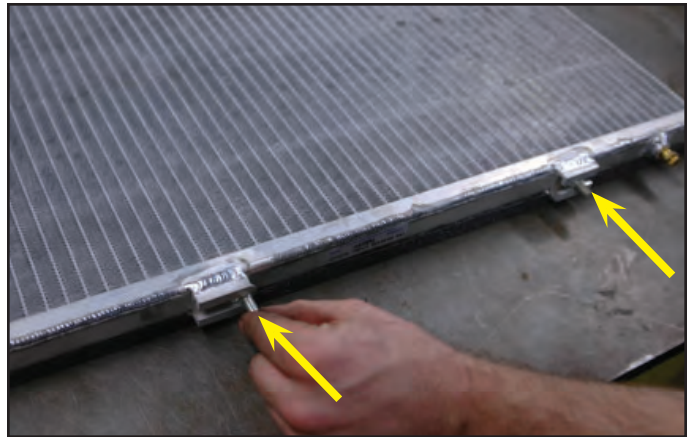

91. Have an assistant push the heat exchanger up from the bottom of the vehicle, in front of the existing air conditioner condenser. Have the assistant hold the heat exchanger in place while you attach the two rubber-backed hangers over the top of the air conditioning condenser, aligning the holes of the bracket with the carriage bolts installed on the heat exchanger. Use the 12mm headed nuts provided to secure the hangers in place.



92. Here are the two upper bracket locations shown with arrows for the attachment points.

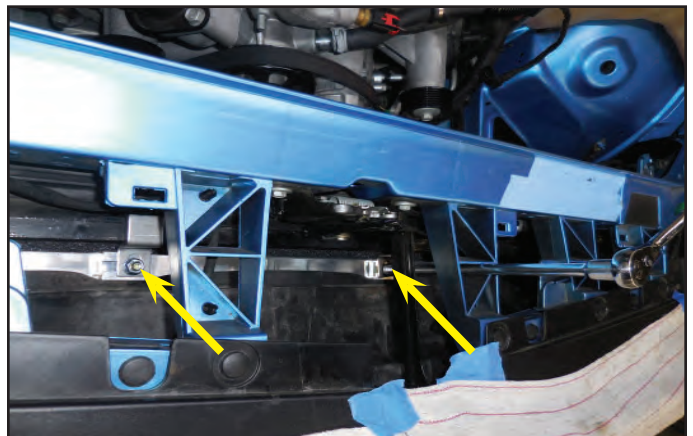

93. Tighten the two radiator mounts that were loosened earlier.



94. Attach the remaining carriage bolt to the passenger side mounting slot on the bottom of the heat exchanger. The remaining vibration damper foam backed bracket will clamp over the bottom of the air conditioning condenser and be secured to the carriage bolt just installed using the remaining 12mm headed nut.

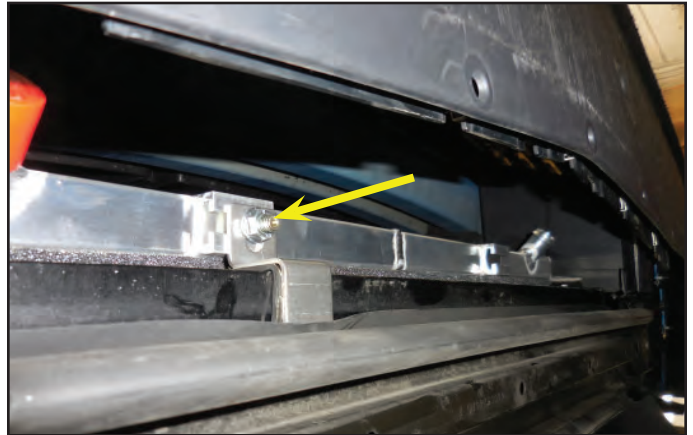

95. Here is the final top LTR mounting location with the two longer brackets.

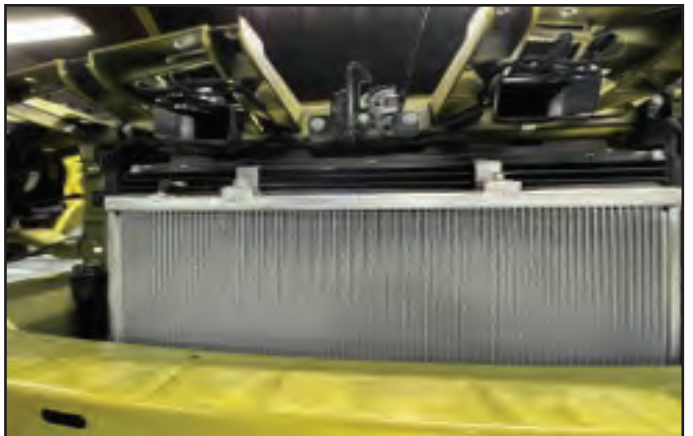

96. Here is the final bottom LTR mounting location with the two shorter brackets. **Note: Some vehicles may have a longer condenser and require the use of 2 long mounting tabs, which are included in this kit.**

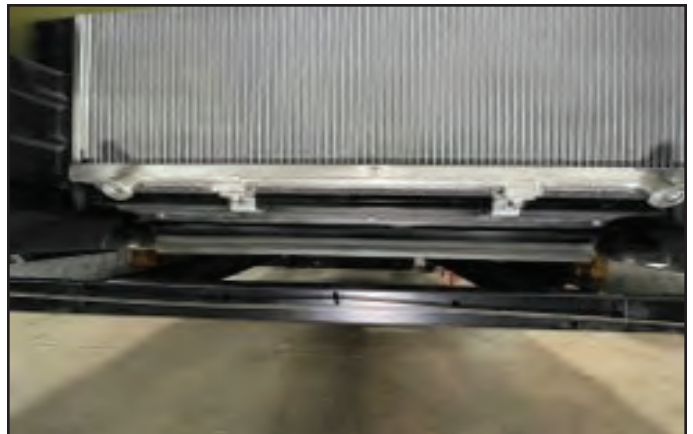

97. Re-install the 2 rad cradle fasteners that were removed in an earlier step. Tighten all 4 fasteners to secure the cradle to the vehicle (RH side shown, LH side similar).

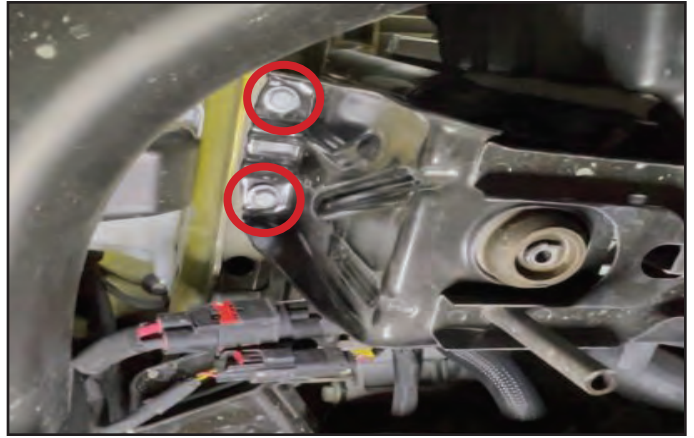

98. The circled threaded hole location will be used for securing the pump mount in the next step.



99. Select a short bracket PN 65-23-64-009 from the kit. Select (1) M6X20mm flanged bolt from the kit PN 71-06-10-020. Select (1) ¼" ID washer from the kit PN 75-00-06-020. Install the washer onto the bolt then install the bolt through the short bracket and into the threaded hole in the factory location shown on the vehicle.



100. Note: automatic transmission vehicles may require the intercooler pump bracket to be bent slightly after installation to allow for sufficient clearance to the trans cooler lines.



101. Select the hose clamp PN 48-46-10-009 from the kit. Install the clamp around the intercooler pump body and over the mounting bracket as shown. Tighten the clamp to secure the pump to the bracket in the orientation as shown.

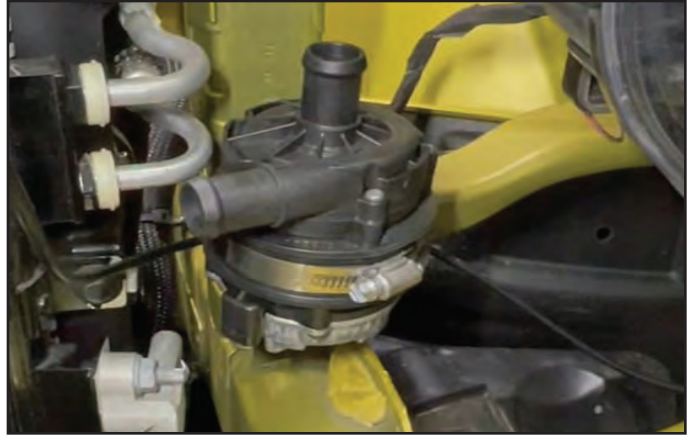

102. Select the intercooler pump relay harness. Route the end with the connector in front of the windshield washer bottle and across the front of the vehicle above the radiator then down toward the plug on the pump. Zip tie the I/C harness to the existing wiring and/or hood latch cable as necessary.

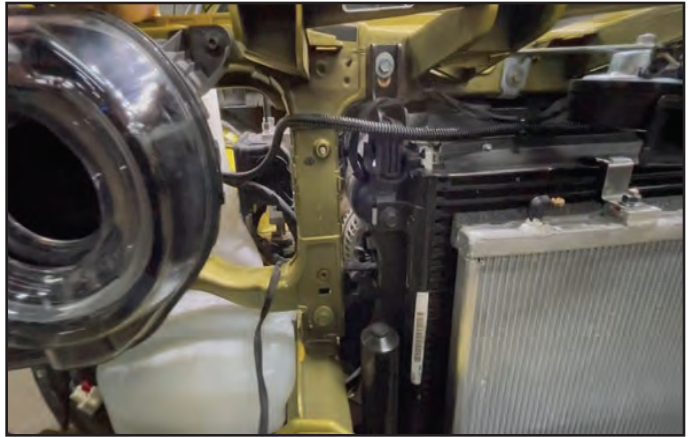

103. Plug the I/C pump harness/adaptor into the pump.

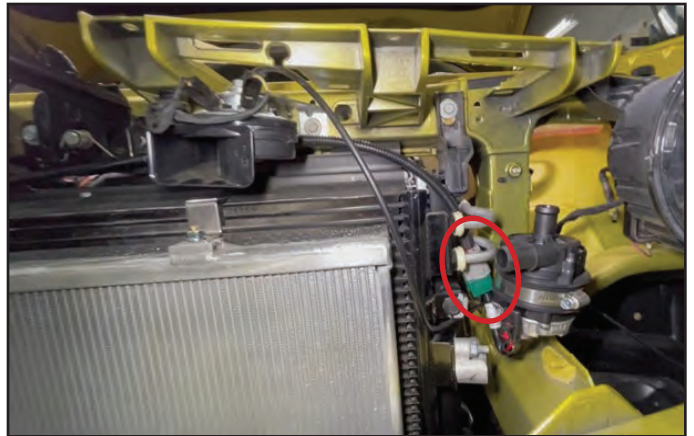

104. Using an M6 X 20mm long bolt and nut from the kit, secure the intercooler relay and fuse to the end of the black bracket next to the fuse box as shown.

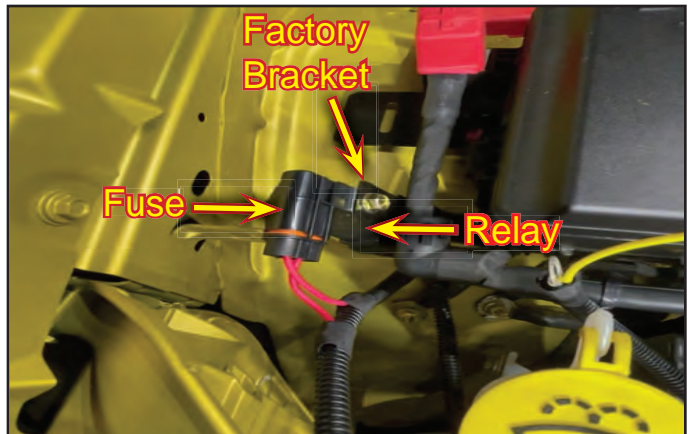

105. Gather the provided 15 Amp fuse and install it into the connector as shown.



106. Snap the fuse connector back into the cover.

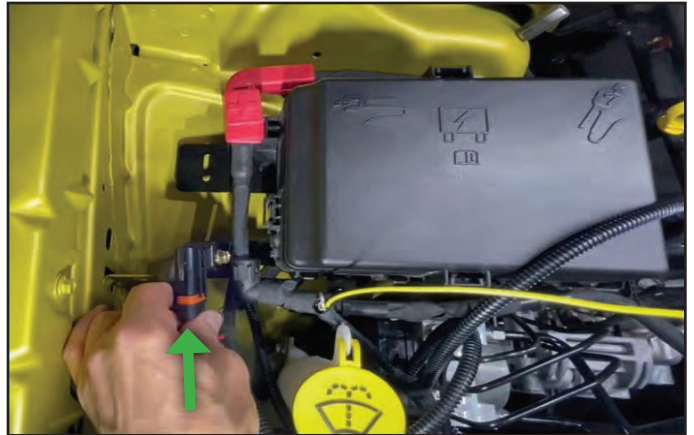

107. Zip tie any extra harness and secure it to the existing vehicle harness by the windshield washer tank.

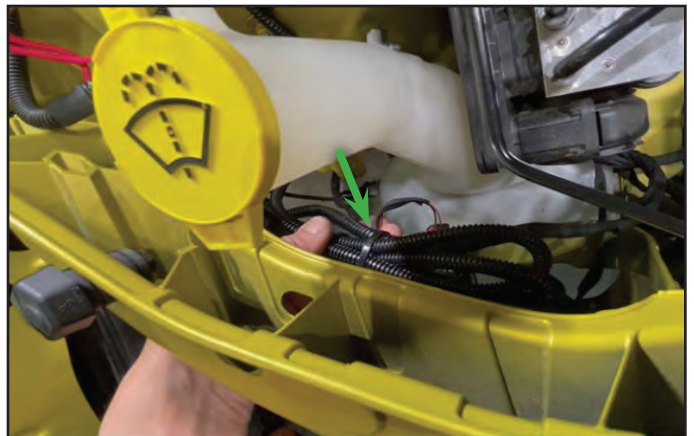

108. Remove the fuse box cover by squeezing the tabs on each side. Set the cover aside.

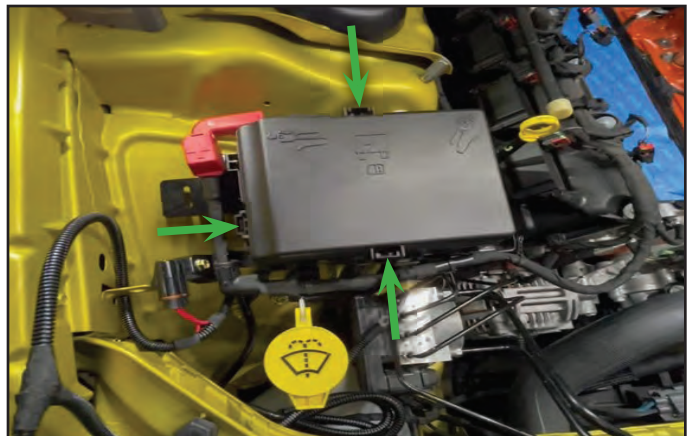

109. Remove the nut at the factory ground connection in the location shown.

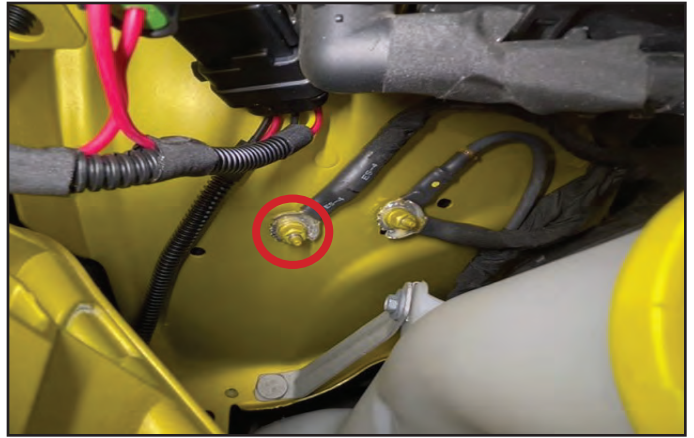

110. Install the BLACK ground wire onto the factory ground stud. Re-install the nut and tighten it.



111. Open the positive cable cover, remove the nut and install the RED lead onto the nut. Re-install the nut and tighten securely.



112. Carefully notch the positive cable cover at the base where the positive lead exits so that it will close properly.

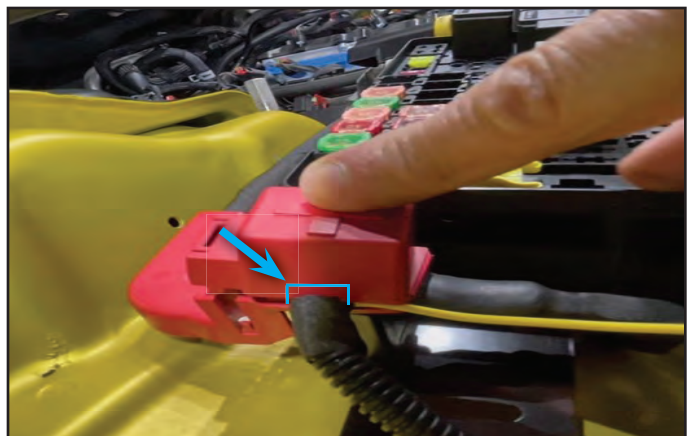

113. Inside the fuse box, use the factory fuse removal tool to remove the 10amp fuse in the arrow location shown.

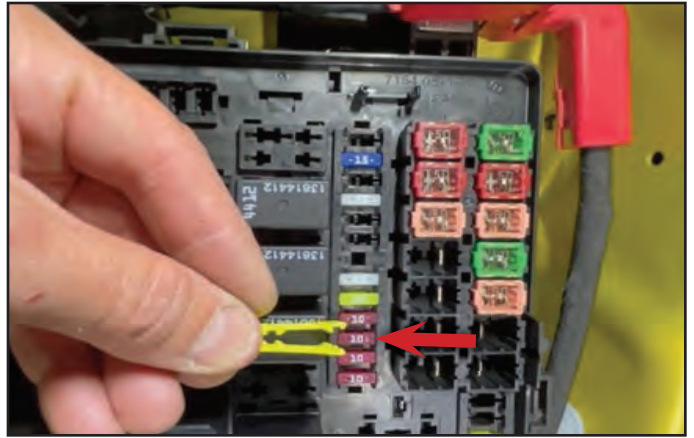

114. Select the new 10amp fuse P/N 82-55-50-210. Slip the fuse into the slot in the end of the brass connector on the yellow trigger lead.



115. Re-install the new fuse/tap assembly back into the factory location, ensuring it is fully seated. Route the yellow trigger wire through the fuse box as shown. Notch the edge of the box to allow the wire to exit at the arrow location.



116. Replace the cover and secure it into the locking tabs.

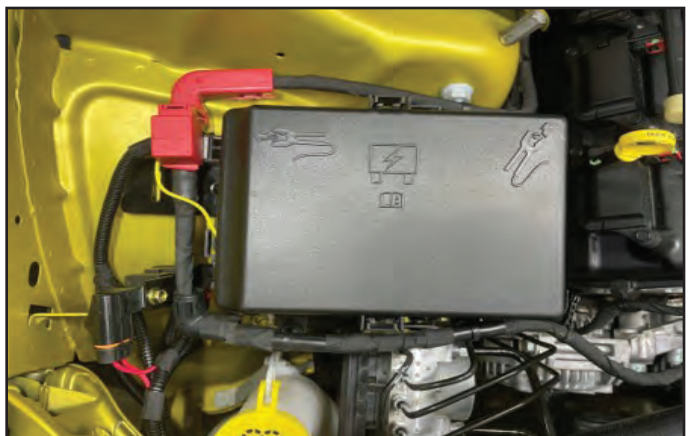

117. Install the I/C pump to LTR hose in the orientation and locations shown. Secure the hose to the tube at the LTR using a  $\frac{3}{4}$ " constant tension clamp.

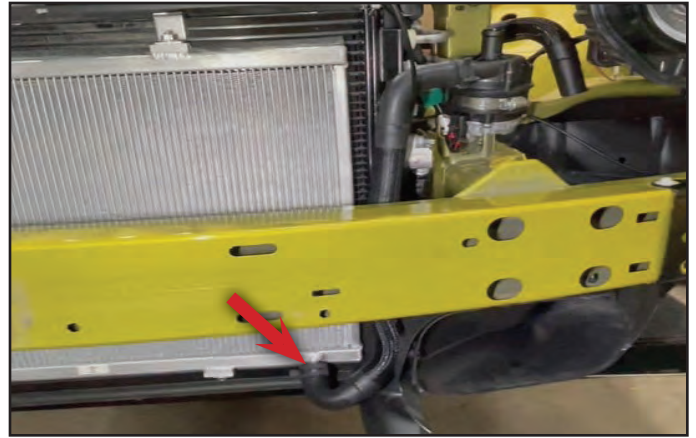

118. Secure the opposite end of the hose to the intercooler pump at the location shown. Use a gear clamp from the kit to secure the hose to the pump.



119. Select the hose shown from the kit.



120. Pre-install the hose (highlighted in green) from the last step to the vehicle as shown. The hooked end of the hose routes down between the alternator and the inside of the frame rail, toward the connection point at the RH side of the low temp radiator.





121. The hooked end of the hose from the last step is shown in the location below the vehicle where it is routed. Drill a hole in the plastic shield at the bottom right corner of the radiator (red arrow) to allow the intercooler hose to pass through.

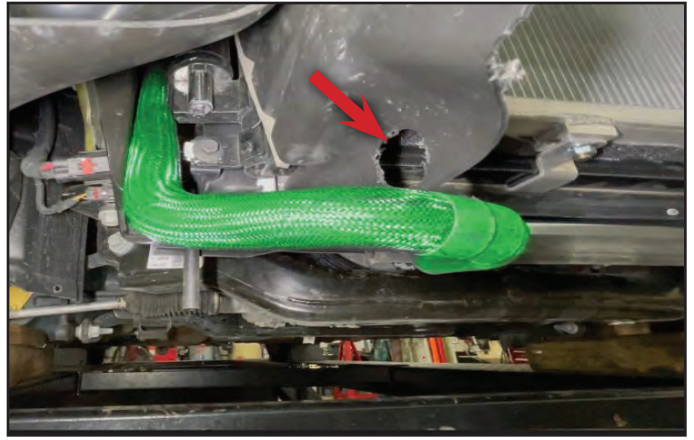

122. Route the hose (highlighted in green) from the last step through the hole, install a constant tension clamp to the end then install the hose onto the LTR. Secure the hose using the clamp.



123. Lubricate and install the 4 ft. long section of 1/4" bulk hose onto the bleed port at the top of the LTR. Secure the hose using a constant tension clamp.



124. Route the hose (highlighted in green) along the top of the LTR and toward the LH side of the vehicle, then through the radiator cradle at the top left corner of the radiator. Final routing and connection of the hose will be detailed in a subsequent step.



125. The supercharger must be partially disassembled prior to installation in the vehicle. Remove all the fasteners securing the upper lid to the base.



126. Remove (6) internal fasteners securing the CAC's to the base.



127. Remove (6) turret fasteners from the front securing the turrets to the base. Three fastener locations are shown here.

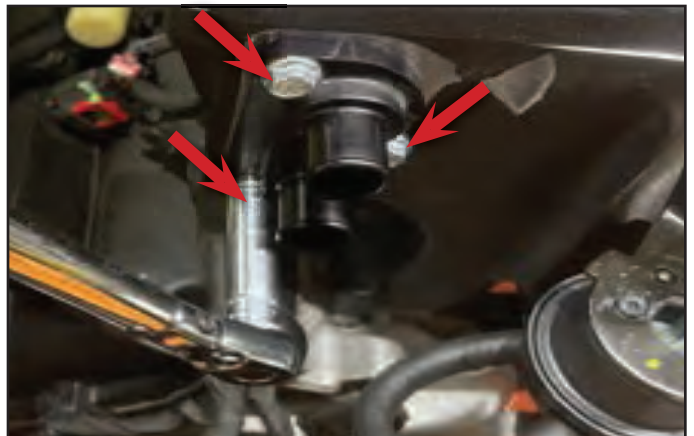

128. Carefully remove the LH and RH CAC's out of the intake and set them aside.

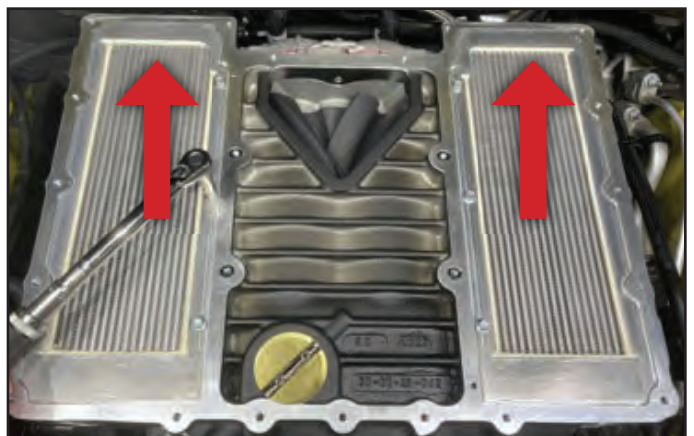

129. Install the IAT sensor PN 82-55-53-020 into the front right corner of the supercharger.



130. Secure the sensor to the intake using an M5 X 0.8 X 10mm long fastener P/N 71-05-08-010. **Torque to 70 in-lbs.**

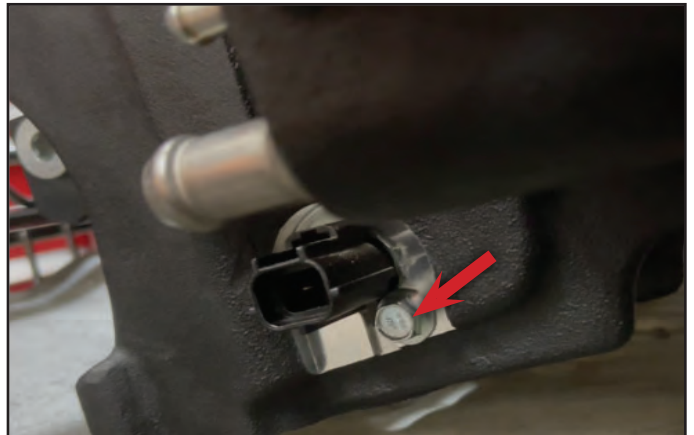

131. Install the new MAP sensor into the LH rear corner of the supercharger PN 82-55-57-009. Secure the MAP sensor to the supercharger using (2) M5X 0.8X20mm long bolts PN 72-05-08-020. **Torque to 70 in-lbs.**

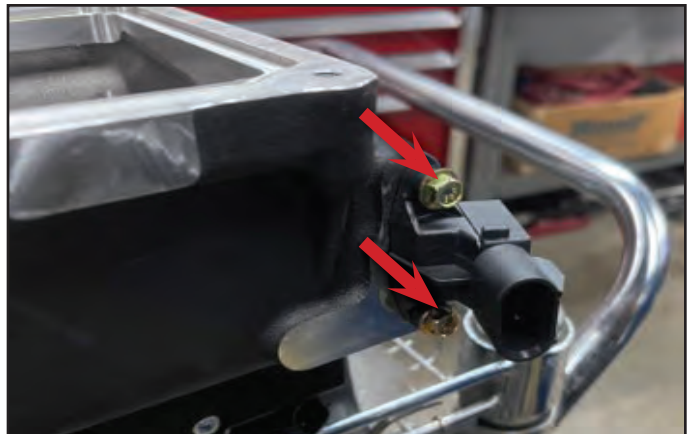

132. Orient and install (2) supercharger to intake gaskets, ensuring the ports for the PCV and oil fill align with the holes in the casting. Secure the gaskets to the supercharger using (4) nylon push pins PN 69-99-05-004 at the 4 green circles.



133. Sub-assemble o-ring PN 80-59-10-128 onto the oil fill adaptor PN 35-26-61-064-BL.



134. Install the oil fill adaptor to the LH side of the supercharger using (4) M6 X 1.0 X 20mm long fasteners PN 71-06-10-020. **Torque bolts to 96 in-lbs. Prototype shown.**



135. Sub-assemble o-ring PN 80-59-10-128 onto the PCV adaptor shown below. Install the PCV adaptor onto the RH side of the supercharger, with the hole angled upward using (4) M6X1.0X20mm long fasteners PN 71-06-10-020. **Torque bolts to 96 in-lbs.**



136. Select the PCV valve Mopar PN 0503 7831 AA. Lubricate the PCV valve o-ring then install the valve into the PCV adaptor.



137. If you are installing a boost gauge, there is a spare 1/8" NPT plug on the RH rear corner of the supercharger for this provision.



138. Select the throttle body spacer PN 35-26-61-041 and gasket 80-99-01-064. Install the gasket and spacer onto the supercharger inlet using (4) M6X1.0X20mm socket head cap screws PN 72-00-06-020. **Torque the fasteners 89 in-lbs.**



139. Remove the stock throttle body from the factory intake. Harvest the factory throttle body gasket from the intake and install it onto the inlet adaptor on the supercharger.



140. Select the supercharger pulley PN 57-03-06-090-BL and (4) fasteners PN 71-06-10-016. Apply blue Loctite to the fasteners then install the pulley onto the front of the supercharger. **Torque the fasteners to 106 in-lbs.**



141. Remove the fur tree connectors securing the wiring harness to the valve covers (6 places).

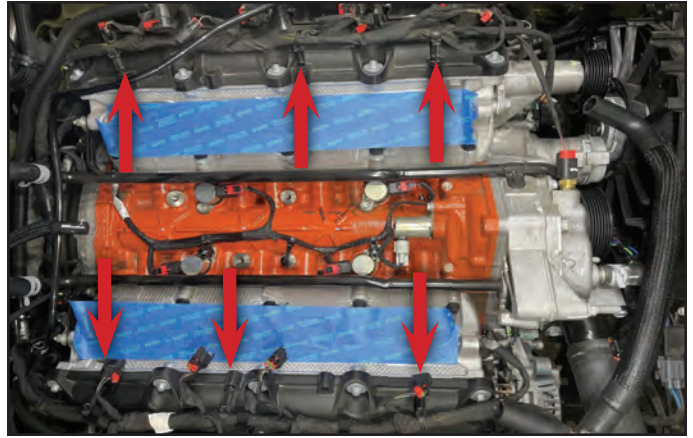

142. Carefully cut and remove the zip tied connections from the harness at all (6) locations.



143. Remove the factory brake booster hose from the brake booster.



144. Flip the hose 180 degrees and install the opposite end to the booster so that it routes toward the LH front of the engine.



**145. FEAD Bracket Sub-Assembly**

Sub-assembly (2) spacers PN 69-90-57-023, (2) idlers PN 56-06-01-060-BL and (2) M10X1.5X40mm long fasteners PN 71-10-15-040 onto bracket PN 65-26-61-023.



146. Idlers must be installed with the snap ring facing the stand-off on the idler bracket. Clamp the idler and bracket sub-assembly in a vice to secure it then **torque the fasteners to 27 ft-lbs.**



147. Remove the fastener holding the heater tube to the water pump casting in the location shown.



148. Remove the nut holding the factory knock sensor to the stud on the back of the LH cylinder head. Remove the stud holding the back of the heater tube onto the LH cylinder head.



149. Remove the heater tube from the water pump and position it out of the way temporarily.



150. Remove the tensioner from the front of the engine using a 16mm socket.

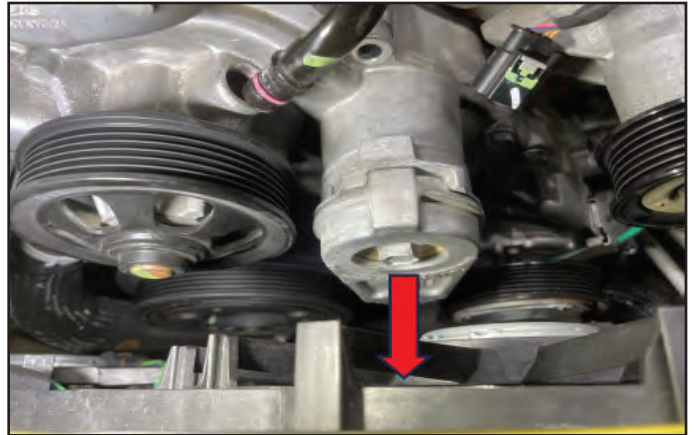

151. Remove the 2 fasteners in the locations shown on either side of the heater tube.

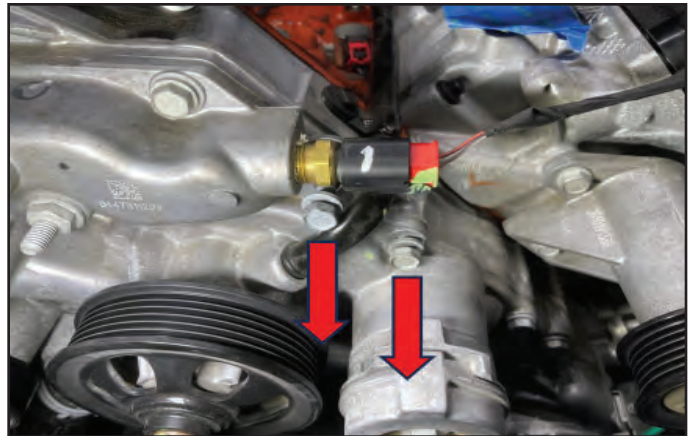

152. Select the following parts: Bracket (PN 65-26-61-025), M8X1.25X110mm long fastener (PN 71-08-12-110), and M8X1.25X40mm long fastener (PN 71-08-12-040). Sub-assemble the fasteners into the bracket as shown in the photo.





153. Install the bracket assembly into the location shown on the water pump housing.  
**Torque the fasteners 18 ft-lbs.**

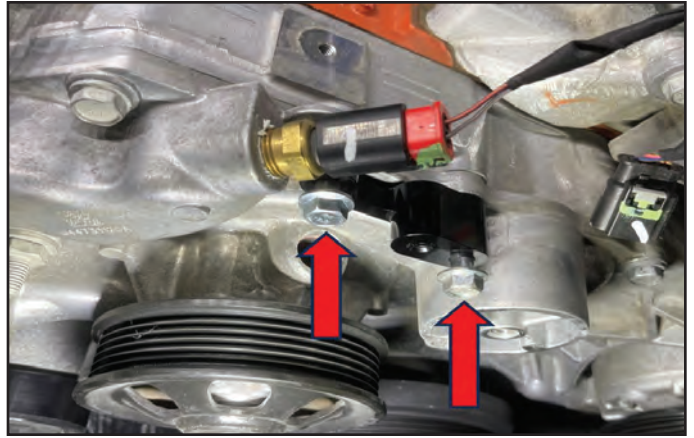

154. Lubricate the o-ring on the heater tube and re-install it into the water pump housing.



155. Re-install the factory bolt securing the heater tube to the water pump housing but do not tighten it.



156. Re-install the stud through the heater tube bracket and into the back of the LH cylinder head. **Torque the stud 18 ft-lbs.**



157. **Torque the front heater tube bolt 96 in-lbs.**



158. Re-install the radio capacitor onto the stud at the back of the LH cylinder head. Secure the sensor with the original nut. **Torque the nut to 96 in-lbs.**



159. Re-install the factory tensioner using a 16mm socket. **Torque the tensioner to 33 ft-lbs.**

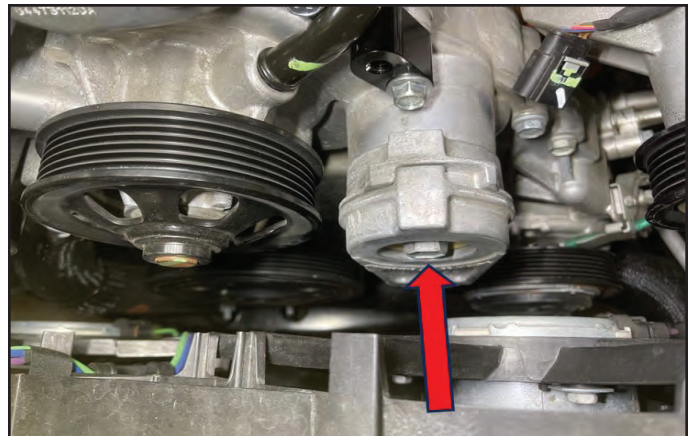

160. Sub-assemble the large billet idler bracket PN 65-26-61-023 with the components shown in the drawing applicable to your model year vehicle (late-model 6.4L version shown, early version similar).





165. Install the bracket sub-assembly onto the front of water pump housing, ensuring the spacers stay on the fasteners. Ensure the belt is routed below the LH stand-off and in between the two idler pulleys as shown.

**Torque (3) bracket bolts 18 ft-lbs.**

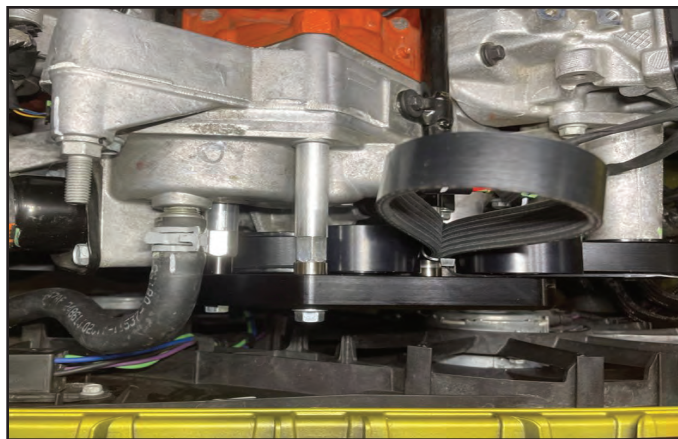

166. Remove any material covering the intake ports. Ensure they are wiped clean and no foreign material has entered the engine.



167. With the aid of a helper, install the supercharger onto the engine



168. Install (10) M6X1.0X40mm long fasteners into the supercharger mounting locations. Hand-start and zero-torque all fasteners in a criss-cross pattern starting from the center out. **Pre-torque all 10 fasteners to 53 in-lbs in sequence. Final torque all 10 fasteners to 106 in-lbs in sequence.**



169. Re-install the charge air coolers into the supercharger ensuring the coolant ports line up with the holes in the front of the housing. Apply blue Loctite to (6) inboard CAC fasteners and re-install them. **Torque them to 84 in-lbs.** Ensure the (4) black o-rings are in place as shown in the photo.

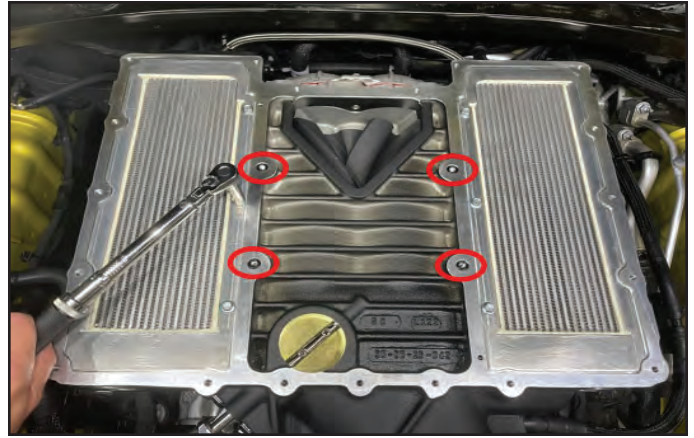

170. Re-install the supercharger lid onto the housing. Re-install all the lid fasteners. Make sure to remove the Magnuson badges to allow access to the four center bolt (M6x30mm) locations circled in red here. These M6x30mm bolts are located in a supplied bag. Follow the sequence for the lid bolts shown at the back of this manual. Zero torque the fasteners first before applying the final torque. **Final torque the lid fasteners to 106 in-lbs.**



171. Select the charge air cooler turrets. Apply Lubriplate to the o-rings as shown below then re-install them to the appropriate sides of the supercharger. **Re-install the original turret fasteners, run them down then final torque them to 106 in-lbs.**



172. Re-connect the wiring harness take-outs for all 8 fuel injectors. Ensure the locks are engaged on all 8 connectors. RH shown, LH side similar.



173. Route the fuel vapor line along the LH side of the engine toward the front of the supercharger. Cyl. #3 coil fasteners may be required to be removed to allow the vapor line to route under the engine oil fill adaptor. Install the fuel vapor line onto the lower port of the supercharger as shown. Re-install the coil bolts if removed. **Torque 89 in-lbs.**



174. Install a 3/8" mender PN 48-46-00-058 (red arrow location) and constant tension clamp (green arrow) onto the end of the brake booster hose. The brake booster hose extension that will be shown in the next step is already attached at the other side of the mender.

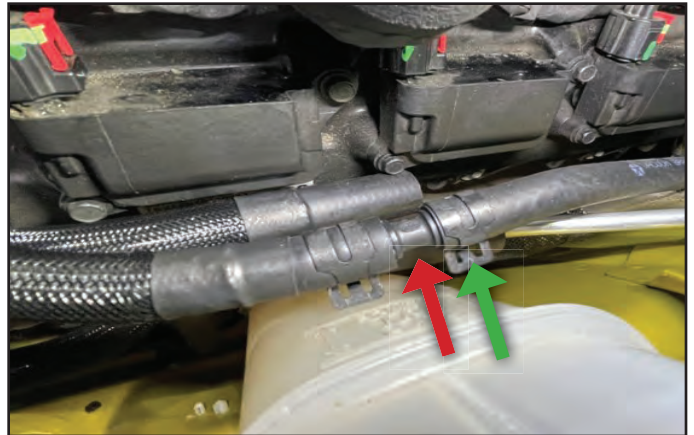

175. Install the brake booster extension hose (highlighted in green) onto the mender that was installed in a previous step. Secure the jumper to the mender with a constant tension clamp.



176. Re-connect the fuel line to the fuel rail on the LH side of the supercharger. Ensure the connector is fully seated, you will hear it click into place. Cycle the red lock on the connector. Pull back on the connector ensuring it does not come off.



177. Select the coolant reservoir mounting bracket PN 65-26-61-029 and (2) M8X1.25X16 fasteners PN 71-08-12-016. Install the bracket to the LH side of the supercharger using the 2 fasteners as shown. **Torque the fasteners to 11 ft-lbs.**



178. Select the oil separator assembly from the kit. Note the airflow direction on the top of the separator.



179. Install the vinyl-coated clamp around the base of the separator body in the orientation shown. Select (1) M6X1.0X12mm long fastener and the aluminum bracket from the separator kit. Apply blue Loctite and install the fastener through the vinyl coated clamp and into the rivnut on the bracket. Orient the parts as shown in the photos.



180. On the vehicle, remove the factory bolt securing the wiper assembly to the cowl in the location shown. Install the separator assembly under the steel washer then re-install the factory bolt and tighten it to secure the separator.



181. Install 3/8" bulk hose (highlighted in green) onto the rear-facing port of the oil fill adaptor. Fully seat the hose over the barb. Route the hose around the back of the supercharger toward the right-hand rear corner of the engine bay.

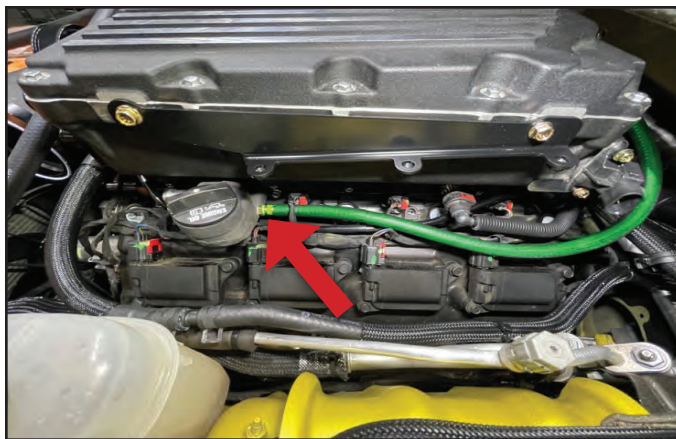

182. Install the opposite end of the hose (highlighted in green) from the last step to the bottom port of the separator ensuring it is fully seated.

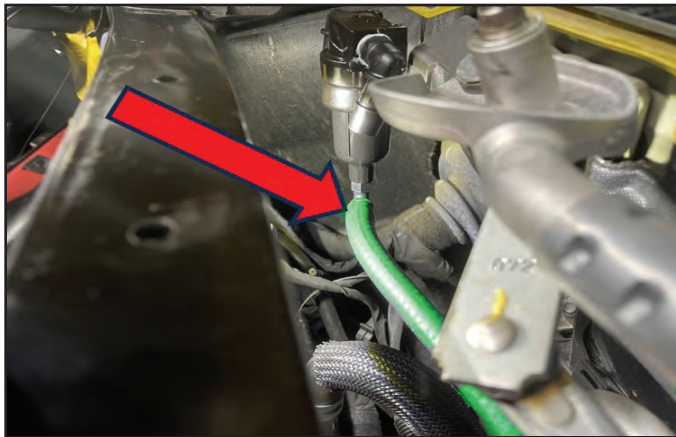

183. Select the hose shown from the kit. Install a 21mm constant tension clamp to the end shown.



184. Apply Lubriplate to the PCV fitting on the RH side of the supercharger then install the hose from the last step to the PCV and secure it with the constant tension clamp as shown.





185. Determine the appropriate place to cut the hose (shown at the dashed line) so that will connect to the RH side of the oil separator. Cut the hose (do not throw away the remaining section).



186. Tape back the protective sleeve as shown, then install a 21 mm constant tension clamp to the hose end. Apply Lubriplate to the RH barb on the separator then install the hose over the barb and secure it with the clamp as shown.

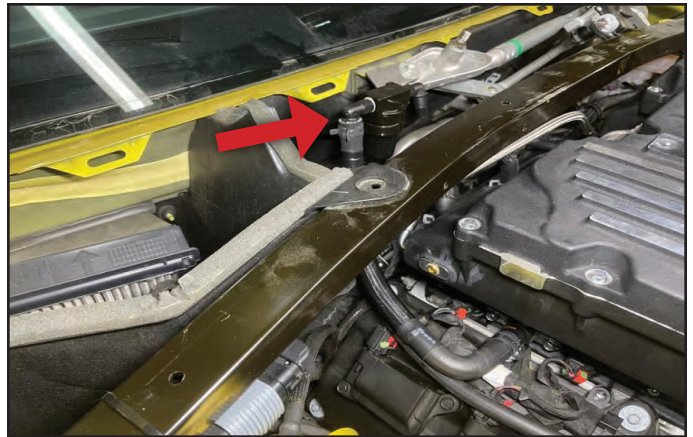

187. Select the hose that was cut in the previous step. Tape back the protective sleeve as shown, then install a 21 mm constant tension clamp to the short hose end. Install a straight hose mender PN 48-46-00-060 onto the short end of the hose. Secure the mender using a 21mm constant tension clamp.



188. Cut approximately 1 inch off the long end of the hose. Install the long end of the hose onto the tube below the supercharger bypass valve in the location shown in the photo. Secure the hose using a small gear clamp.

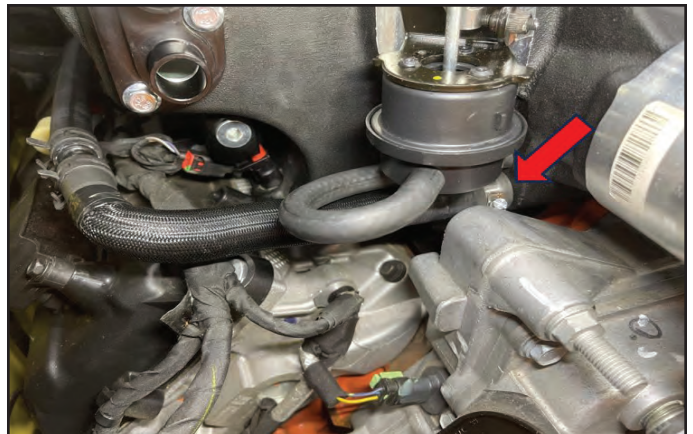

189. Select the length of ½” bulk hose (highlighted in green) from the kit. Install a 21mm constant tension clamp from the kit onto one end of the hose. Apply Lubriplate to the final remaining hose connection on the LH side of the oil separator. Secure the hose to the oil separator using the clamp.



190. Route the hose (highlighted in green) from the oil separator, under the cowl, then along the RH side of the supercharger. Cut the hose to length and attach it to the straight mender (arrow location) on the hose installed in the previous step, securing it with a 21mm constant tension clamp.

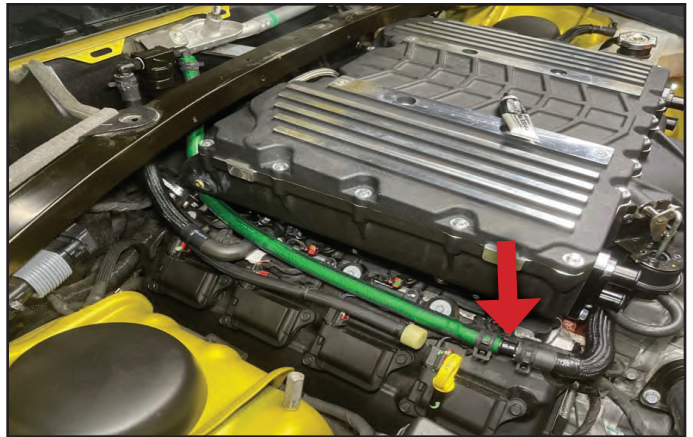

191. Install the CAC hoses to the LOWER charge air cooler ports on the supercharger. Secure the hoses using ¾” constant tension clamps.

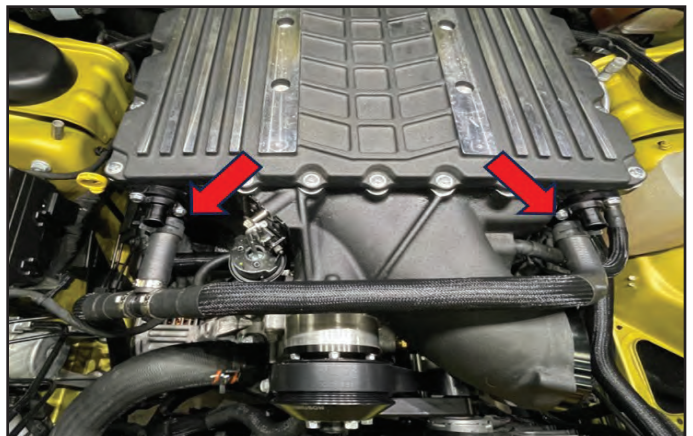

192. **6.4L engines Only:** install MAP sensor jumper harness PN 82-55-80-042 between the new sensor at the LH rear of the supercharger and the factory connector at the RH rear of the engine compartment.



193. Gather the supercharger coolant reservoir. Use (3) M6X1.0X16mm long fasteners PN 71-06-10-016 to secure it to the bracket on the LH side of the supercharger.

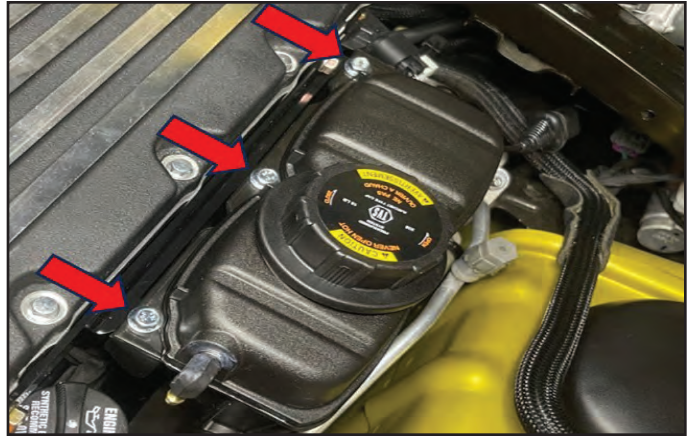

194. Select the pre-formed hose shown from the kit shown below. Install the end with the 90 degree bend through the front cradle beside the radiator and onto the coolant pump as shown. Secure the hose with a gear clamp.

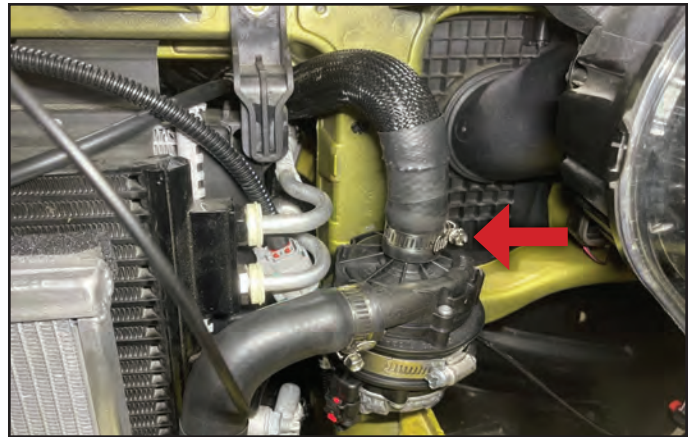

195. Route the opposite end of the pre-formed hose (highlighted in green) from the last step toward the intercooler reservoir. Install the hose to the front of the reservoir and secure it with a  $\frac{3}{4}$ " constant tension clamp as shown.



196. Find the  $\frac{1}{4}$ " hose previously installed to the low temp radiator. Route the  $\frac{1}{4}$ " hose along side the  $\frac{3}{4}$ " hose installed in the previous slide. Trim the hose to length as necessary then apply Lubriplate to the hose barb on the reservoir and install the  $\frac{1}{4}$ " hose, securing it with a  $\frac{1}{4}$ " constant tension clamp.



197. Use zip ties to secure the 1/4" hose beside the 3/4" hose as necessary.

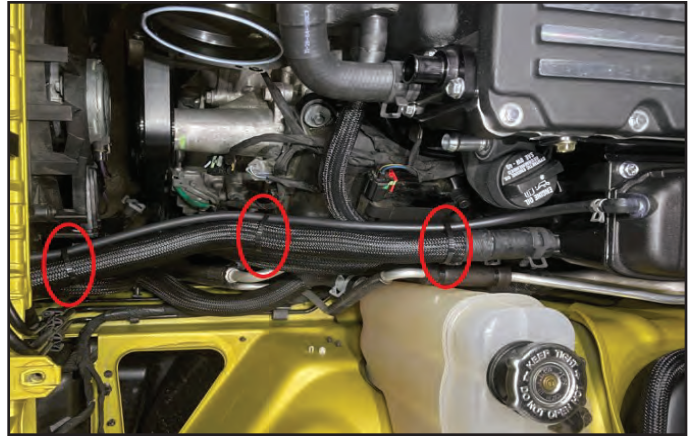

198. Select the hose assembly shown in the attached photo.



199. Install the hose assembly onto the charge air cooler upper ports as shown. Secure the hose using 3/4" constant tension clamps.

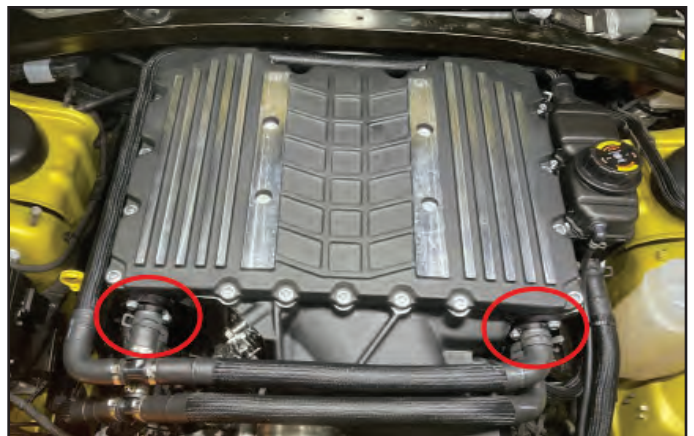

200. Route the opposite end of the hose around the back of the supercharger, over to the fitting on the back of the coolant reservoir. Select a 3/4" constant tension clamp, install it over the hose then install the hose onto the fitting at the back of the reservoir.



201. Install the factory throttle body using (4) M6X1.0X40mm long fasteners PN 71-06-10-040. Tighten the throttle body fasteners in a criss-cross pattern. Install the throttle body electrical connection and cycle the lock on the connector.



202. Install the new clean air tube onto the throttle body. Install the air box back into the vehicle and re-secure it using the factory bolts. Secure the clean air tube to the throttle body and air box using the provided constant tension clamps.



203. Install the 6 inch long piece of 5/8" I.D. rubber hose between the clean air tube and the oil fill adaptor. Secure the rubber hose using (2) 5/8" constant tension clamps as shown.



204. If your vehicle has a Mopar cold air intake kit installed, install the 1/2" rubber plug onto the air box fitting in the location shown. Note: cold air kit upper lid that fastens to the underside of the hood must be removed (insufficient clearance to supercharger)

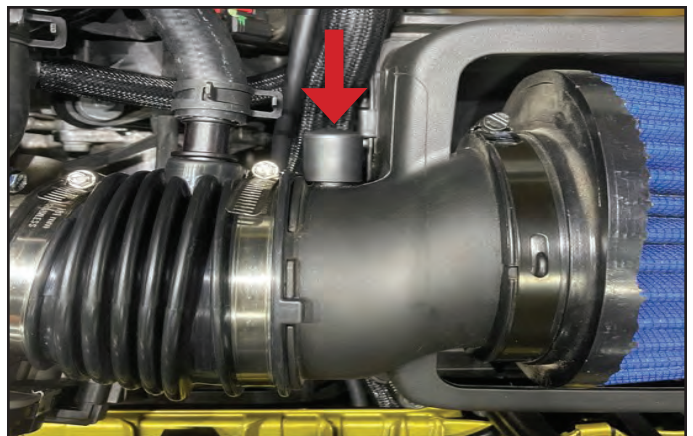

205. **6.4L Engines Only:** Install the intake air temp jumper harness PN 82-55-53-009 to the factory connection at the LH front of the engine.



206. **6.4L Engines Only:** Route the jumper harness under the front of the supercharger and over to the sensor located on the RH front corner, under the bypass valve. Plug the harness into the sensor ensuring it locks into place.



207. Re-install the bracket to the PCM in the orientation shown. Secure the bracket using the (2) factory nuts.



208. Re-install the PCM / bracket sub-assembly back in the RH side of the cowl. Re-attach both PCM connectors and the hood latch sensor connector.



209. Secure the PCM bracket to the cowl using the factory bolt.



210. Tape up the factory CMCV connector with electrical tape.

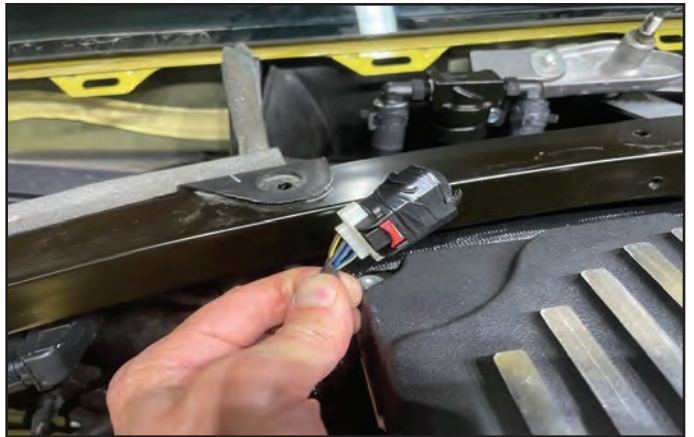

211. Re-install the cowl cover, ensuring the clips locate back into their respective locations. Re-install all push pins.

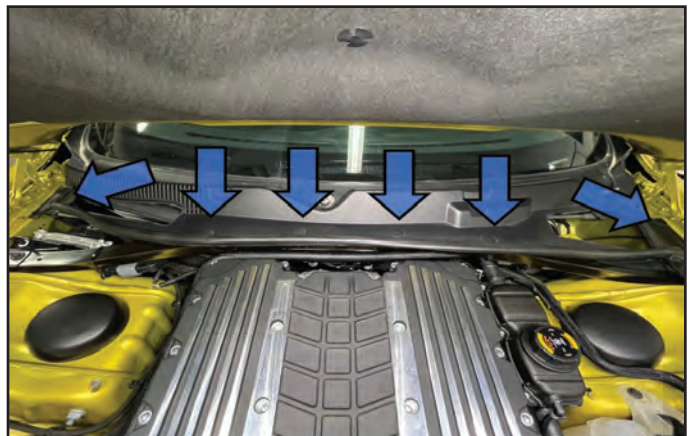

212. Re-install the wipers, aligning the blades with the alignment marks at the base of the windshield (LH side shown at red arrow, RH side similar). Secure them to the posts using the factory nuts. Re-install the covers over the nuts by snapping them back into place. Also at this time reinstall the LH and RH cowl trim panels. The left side panel is shown at the green arrow.

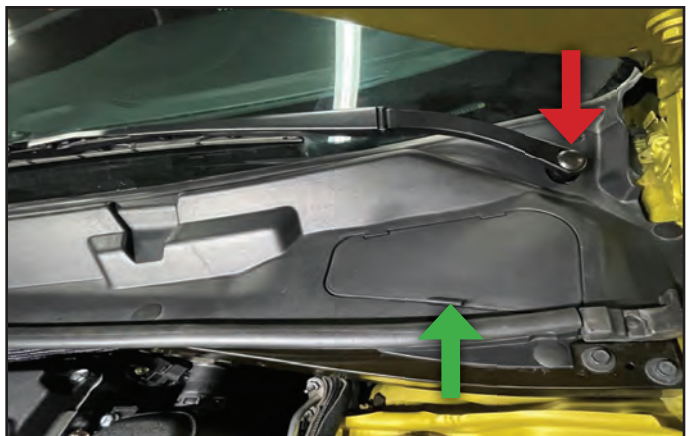

213. Re-install the LH and RH foam rubber trim pieces into each side of the cowl (LH side shown, RH side similar).

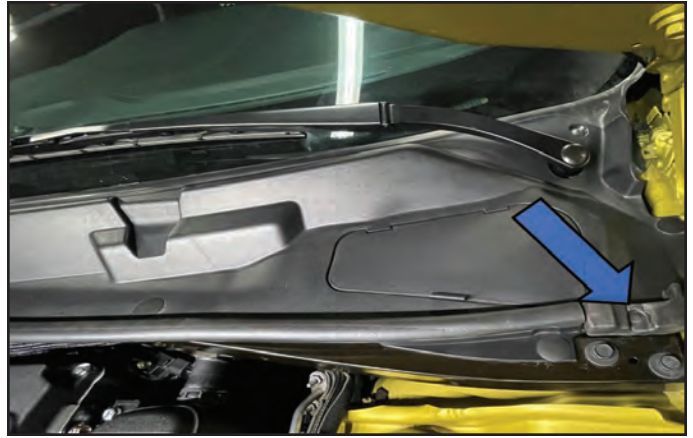

214. Re-fill both coolant systems with Mopar antifreeze PN 68163849AB.



215. Re-connect the battery.



**Make sure that you have followed step #1 in this manual to load the proper supercharger calibration to your vehicle's PCM.**



216. Re-install the plastic panel in front of the radiator. Secure it using the original trim fasteners in the locations shown.





217. Note: ensure the panels do not pinch off the low temp radiator hoses. The panel ends may have to be trimmed to allow clearance.

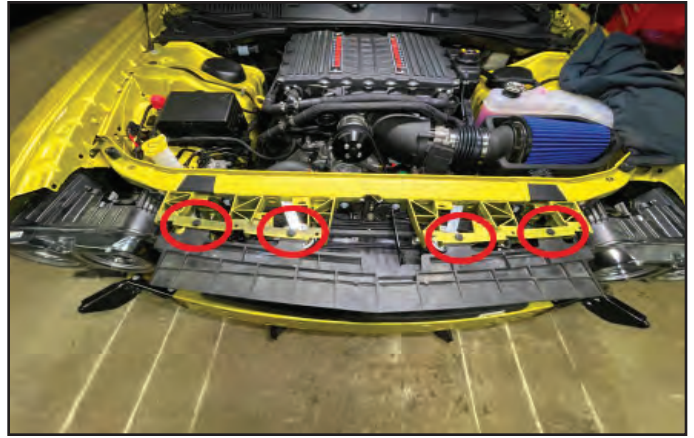

218. Re-install the front fascia, reversing the steps outlined at the beginning of the manual for removal.

Re-install the cowl, access panels and wipers, reversing the steps outlined at the beginning of the manual for removal.

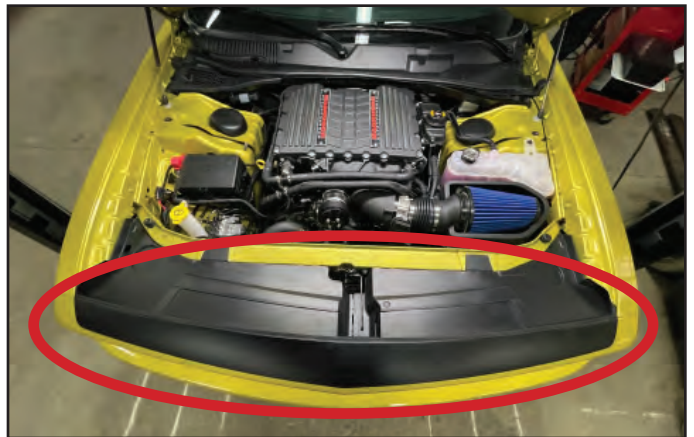

219. Start the vehicle and check for leaks. Verify the coolant levels in both reservoirs.



220. Test drive your vehicle for a while taking care to not get into boost immediately. **Do not perform any wide open throttle tests at this time.** Pay close attention to the sounds of your engine, if you notice detonation (pinging) back off immediately and contact your installation facility. The supercharger does have a whining sound while under boost. When you are through with the initial test drive check again for any leaks, and top off with coolant if necessary.



221. After the initial test drive, gradually work the vehicle to wide open throttle runs. Listen for any engine detonation (pinging). If engine detonation is present, let up on the throttle immediately. Most detonation is caused by low octane fuel still in the tank. **NOTE: PREMIUM GASOLINE FUEL MUST BE USED, 91 Octane or better.** If you have questions about your vehicles performance, please check with your installation facility.



**After you finish your installation and road test your vehicle, please fill out the warranty registration. This can be found on our website.**

# Appendix

**HEMI FEAD IDLER BRACKET ASSEMBLY  
2009-10 5.7L AND ALL 6.1L**

ITEM NO.	PART NUMBER	DESCRIPTION	QTY.
1	FAB8-130_MISUMI	STUD, M8-1.25 X 130	1
2	FAB8-100_MISUMI	STUD, M8-1.25 X 100	1
3	69-05-00-065	STAND-OFF, 20MM OD X 37.7MM LG, 18MM HEX	1
4	69-05-00-064	STAND-OFF, 16MM OD X 73.2MM LG, 14MM HEX	1
5	65-26-61-025	BRACKET, SUPPORT, FEAD IDLER	1
6	71-08-12-110	HEX FLANGE BOLT, M8-1.25 X 110	1
7	71-08-12-040	BOLT, HEX FLANGE, M8-1.25 X 40, CL10.9, ZINC	1
8	65-26-61-023	BRACKET, FEAD IDLER, BILLET	1
9	69-90-57-023	SPACER, IDLER, 78MM LG	2
10	56-06-01-060-BL	IDLER WITH BEARING, 60MM OD X 29MM WIDE	2
11	71-10-15-040	HEX FLANGE BOLT, M10-1.5 X 40	2
12	NCLA8-16-47.3_MISUMI	SPACER, 16MM OD X 8MM ID X 47.3MM LG	1
13	71-08-12-035	HEX FLANGE BOLT, M8-1.25 X 35	1

**MAGNUSON** POWER TRAIN PRODUCTS  
 2000 WILSON AVENUE  
 SUITE 100  
 JARVIS, CA 94531  
 TEL: 925-938-4111  
 FAX: 925-938-4112  
 WWW.MAGNUSON.COM

DATE: 05/15/23  
 DRAWN BY: JHEWETT  
 CHECKED BY: JHEWETT  
 APPROVED BY: JHEWETT

**MAGNUSON PRODUCTS**  
 VPP/INCLL DRIVE  
 1000 WILSON AVENUE  
 SUITE 100  
 JARVIS, CA 94531  
 TEL: 925-938-4111  
 FAX: 925-938-4112  
 WWW.MAGNUSON.COM



# Appendix

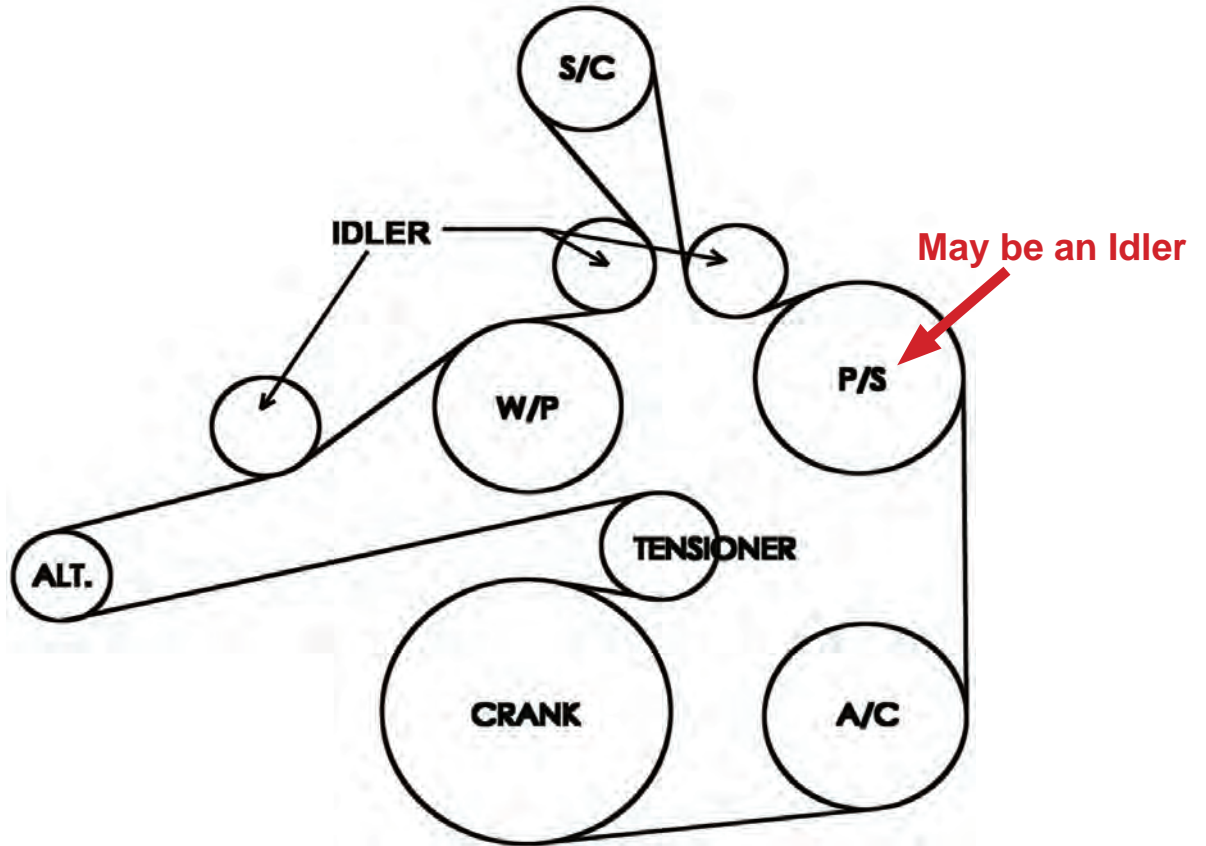

## Challenger HEMI Belt Routing Diagram

(Note: An idler replaces the power steering pulley (P/S) for 2013+ vehicles with electronic power steering)

# Torque Specifications

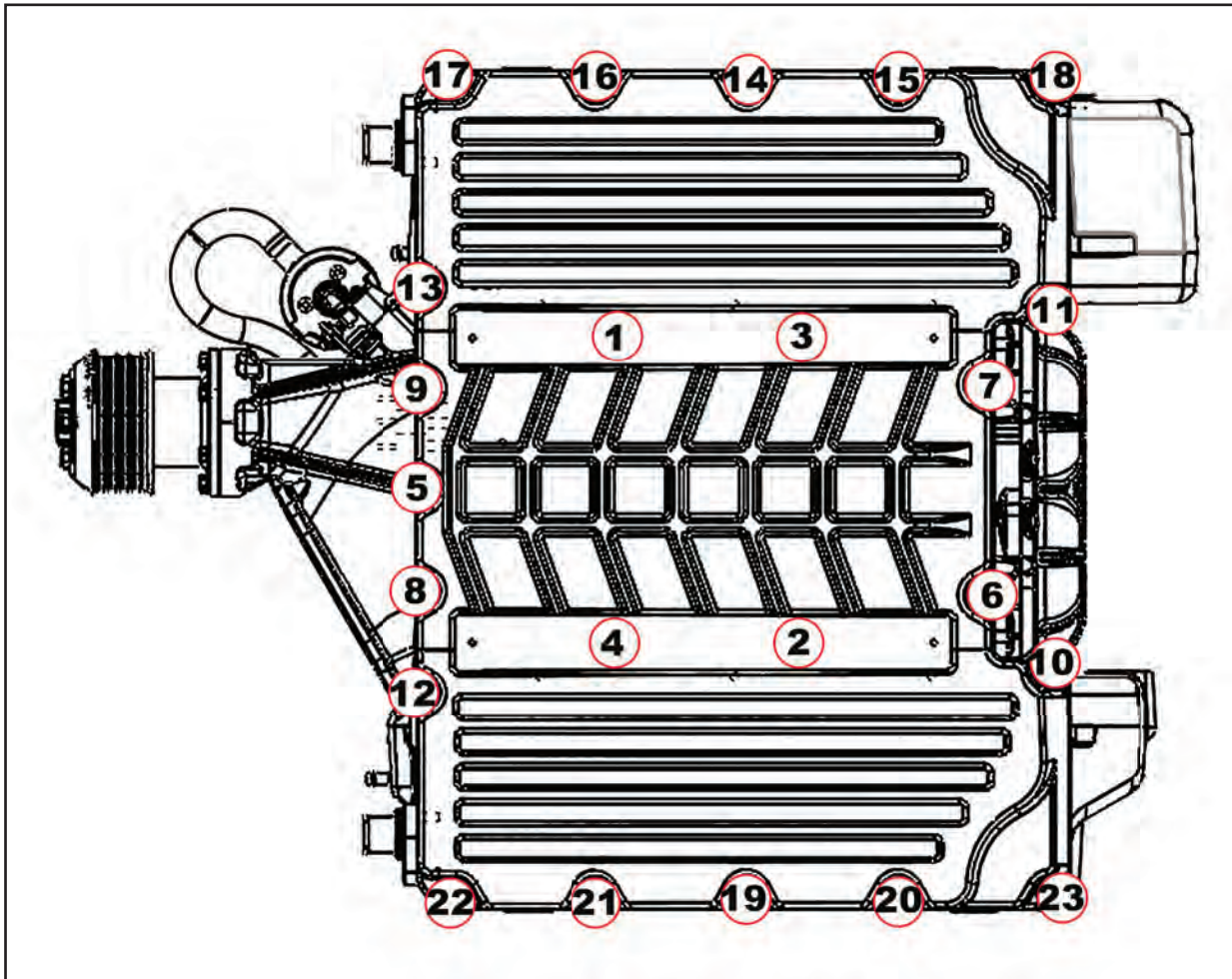

**Lid to Supercharger Housing: 106in-lbs  
(This image is from our LT1 kit but the  
sequence is the same)**

# Notes

# Notes



If you have questions about your vehicles performance, please check with your installation facility.

**This supercharger system requires the use of only premium gasoline fuel, 91 octane or better. It is NOT compatible with E85, Ethanol, Flex Fuels.**

**NOTE: Your supercharger system is sensitive to corrosion. You must use the vehicle manufacturer specified coolant mixture in the intercooler system as well as your radiator.**

**MAGNUSON**  
*SUPERCHARGERS*