

MAGNUSON

SUPERCHARGERS

Installation Instructions for: **2014+ Sierra & Silverado** **5.3/6.2L DI** INTERCOOLED SUPERCHARGER SYSTEM



Step-by-step instructions for installing the best in
supercharger systems.

*** PREMIUM GASOLINE FUEL REQUIRED ***



ATTENTION!
Your **MAGNUSON SUPERCHARGER** kit
is sensitive to corrosion!
Use only the vehicle manufacturer
recommended coolant for your engine in
the intercooler system as well.

Magnuson Products LLC
1990 Knoll Drive, Bldg A, Ventura, CA. 93003
(805) 642-8833
magnusonsuperchargers.com

INSTALLATION MANUAL

Magnuson Products
Intercooled Supercharger System
GM 5.3L, 6.2L DI Engines

Please take a few moments to review this manual thoroughly before you begin work: Make a quick parts check to make certain your kit is complete (see shipper parts list in this package). If you discover shipping damage or shortage, please call your dealer immediately. Take a look at exactly what you are going to need in terms of tools, time, and experience. Review our limited warranty with care. When unpacking the supercharger kit DO NOT lift the supercharger assembly by the black plastic bypass actuator. This is pre-set from the factory and can be altered if used as a lifting point!

Caution: Relieve the fuel system pressure before servicing fuel system components in order to reduce the risk of fire and personal injury. After relieving the system pressure, a small amount of fuel may be released when servicing the fuel lines or connections. In order to reduce the risk of personal injury, cover the regulator and fuel line fittings with a shop towel before disconnecting. This will catch any fuel that may leak out. Place the towel in an approved container when the job is complete.

This supercharger system requires the use of only premium gasoline fuel, 91 octane or better. It is NOT compatible with E85, Ethanol, or Flex fuels.

Magnuson Products recommend that you run a minimum of one (1) tank of premium fuel through your vehicle prior to installation of the system to prevent any possible damage that may occur due to running the supercharged engine on lower octane fuel. **DO NOT add octane booster to existing fuel in your vehicle.**

Magnuson Products Supercharger systems are designed for engines and vehicles in “GOOD” mechanical condition. Magnuson Products recommend that a basic engine system “Health Check” be performed prior to the installation of this supercharger system. Be sure to check for any pending or actual OBDII codes and fix/repair any of the stock systems/components causing these codes. If there are codes prior to the installation they will be there after the installation.

Magnuson Products also recommend the following services to be performed on your vehicle before starting and running the vehicle post supercharger system installation:

- Fuel Filter change
 - Engine oil and oil filter change using the vehicle manufacturer’s specified products
- NOTE: It is VERY IMPORTANT to use the factory specified oil viscosity. The original equipment manufacturer has selected this grade of oil to work with your other engine systems such as hydraulic chain tensioners and variable cam controls. Deviation from this specification may cause these systems to fail or not function properly. Please refer to your owner’s manual for the recommended oil viscosity for your engine and application.
- On newer vehicles not requiring new spark plugs it is important to verify the spark plug air gap.

On older vehicles Magnuson Products recommend these additional services to be performed:

- New spark plugs with the air gap set at the factory specifications OR new specifications if required by the installation manual.
- Engine coolant system pressure test and flush and refill.

NOTE: YOU MUST USE THE GM SPECIFIED COOLANT MIXTURE!

Non “Magnuson Approved” calibrations or “tuning” will Void ALL warranties and CARB certification.

Tools Required

- Safety glasses
- Metric wrench set
- 1/4", 3/8", and 1/2" drive metric socket set (standard and deep)
- 3/8" and 1/2" drive foot pound and inch pound torque wrenches
- 1/2" breaker bar (for tensioner)
- Phillips and flat head screwdrivers
- Pliers, and cutters

IMPORTANT

NOTES:

- 1. For the purpose of these instructions, all references to left hand side or right hand side shall be interpreted as if being seated in the driver seat of the vehicle.**
- 2. It is IMPORTANT to utilize 91 Octane gasoline or better with your supercharger system. Before starting this installation, on an empty tank, fill your tank to full with 91 Octane gasoline or better.**
- 3. Never add Octane booster to your fuel. If you have used Octane Booster in the past, replace your spark plugs and check your O2 sensor before completing your supercharger install.**
- 4. Your supercharger system is sensitive to corrosion. Use only the OEM recommended coolant mixture for your supercharger system as well as your engine.**
- 5. Please remember to follow all safety rules that apply when working, including:**
 - **Wear eye protection at all times**
 - **Do not work on a hot engine**
 - **Be careful around fuel – use shop towels to catch any spills and dispose of towels properly**

Contact Information:

Magnuson Products LLC
1990 Knoll Drive, Bldg A
Ventura, CA 93003

Sales/Technical Support Line: (805) 642-8833
Website: www.magnusonsuperchargers.com
Email: sales@magnusonsuperchargers.com

Table of Contents

| | |
|---|----|
| Section 1: Tuning your Vehicle Computer and Initial Steps | 5 |
| Section 2: Removing Factory Intake Manifold and Accessories | 6 |
| Section 3: Removing Fascia/Grille and Install Low Temperature Radiator | 12 |
| Section 4: Initial Plumbing and Intercooler Pump Install for Heat Exchanger | 21 |
| Section 5: Removing Drive Belt and Preparing Supercharger | 24 |
| Section 6: Install Supercharger | 29 |
| Section 7: Install Drive Belt, Finish Plumbing/Wiring of Intercooler System | 32 |
| Section 8: Install Air Quality Control and System Monitoring Devices | 40 |
| Section 9: Install Fascia/Grille and Finalizing Installation | 46 |

Section 1: Tuning your Vehicle Computer and Initial Steps

1. **If your kit has a provided handheld tuner follow the instructions in the provided pamphlet to install your tune. Your handheld tuner may not match the one shown.**



2. Your Intercooler system is sensitive to corrosion. It's very important to use the OEM recommended coolant mixture in your supercharger system as well.



3. Your system requires the use of minimum 91 Octane gasoline fuel. This system is not compatible with E85 fuel.



4. Loosen the nut shown with an arrow to disconnect the negative battery terminal. Cap or cover the terminal to protect against accidental contact with the battery post.



Section 2: Removing Factory Intake Manifold and Accessories

5. Using an 8mm nut driver or a flat blade screwdriver, loosen the clamp at the throttle body.



6. Depress the gray locking tab to release the PCV vent hose coming from the valve cover at the air plenum on both sides of the engine. Remove these two hoses for later reinstallation.



7. Loosen the clamp at the air box securing the air plenum in position.



8. Remove the air intake plenum from the vehicle. This will not be reused.



9. Remove bolt securing the bracket in the location shown.



10. Remove the bracket shown. This will not get reused.

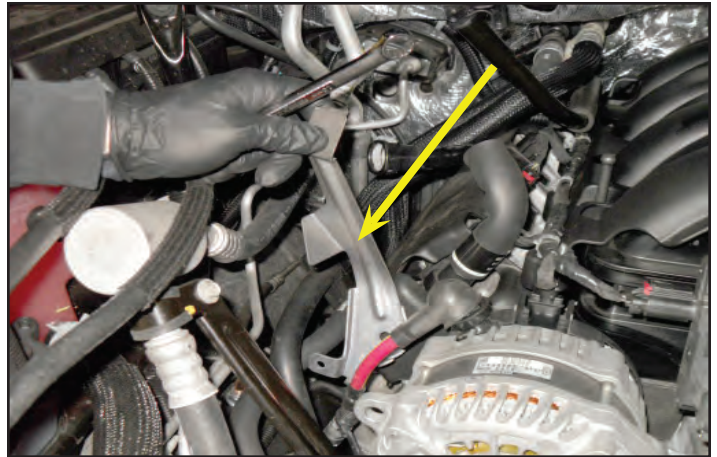

11. Disconnect the ETC connector from the throttle body. Depress the locking tab and pull the connector free.



12. Disconnect the alternator control sensor plug from the alternator.



13. Pull the four “tree” tab wire loom mounting anchors from the holes in the right side of the intake manifold.



14. Unplug the electrical connector from the MAP sensor. Release blue locking tab first.



15. Use a 10mm wrench to remove the EVAP Solenoid from the intake manifold. This is located just behind the throttle body on the left side, below the MAP Sensor.



16. With the EVAP Solenoid free you can now remove the electrical connection by pressing the release tab and unplugging.



17. With the EVAP Solenoid free, you can now easily disconnect the EVAP tube from the Solenoid by pressing the gray release tab and pulling free. Save the EVAP Solenoid, and its fastener, for a later step.



18. Remove the PCV hose from the valley cover on the left side below the throttle body.



19. The 2017 or newer Sierra/Silverado have the PCV hose as shown here at the arrow locations and must be removed.

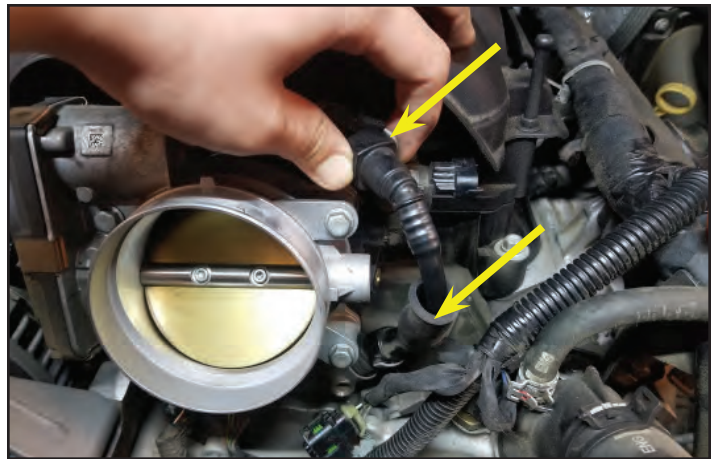

20. Rotate the hose approximately 180° to gain access to the release tab on the left side valve cover, depress the tab and pull the hose free from the vehicle. Set aside for later usage.



21. Use a 10 mm wrench to remove the nut holding the wire harness to the base of the bracket in front of the left side valve cover.

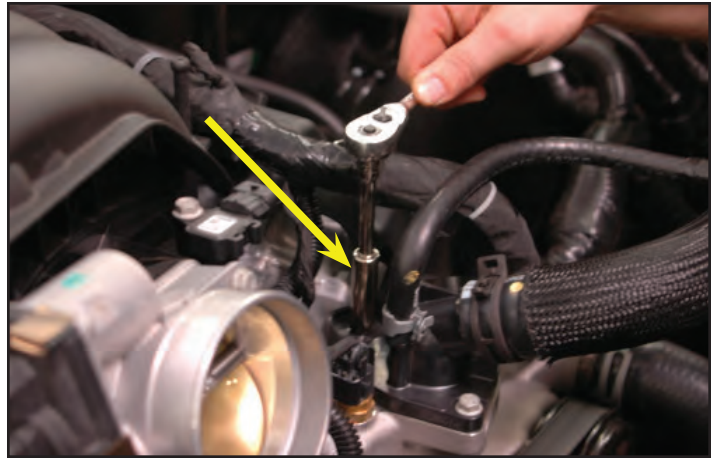

22. **This does not apply to the 2017 or newer Sierra/Silverado.** Use a 10 mm wrench to remove the bolt from the lower mounting bracket anchoring the wire harness.

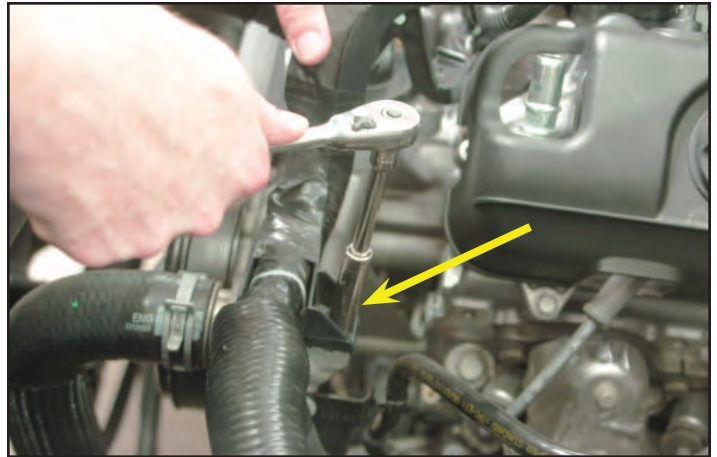

23. Remove the three harness “tree” clamps from the left side of the intake manifold.



24. Use a 10mm socket wrench to remove the ten bolts securing the OEM intake manifold to the heads. The intake manifold is now ready for final removal from the vehicle.



25. Pull the intake manifold forward a bit to gain access to the wiring harness “tree” anchors that hold the harness to the back of the intake manifold. Use a screwdriver or tree clamp remover to unplug these trees from the OEM intake manifold.

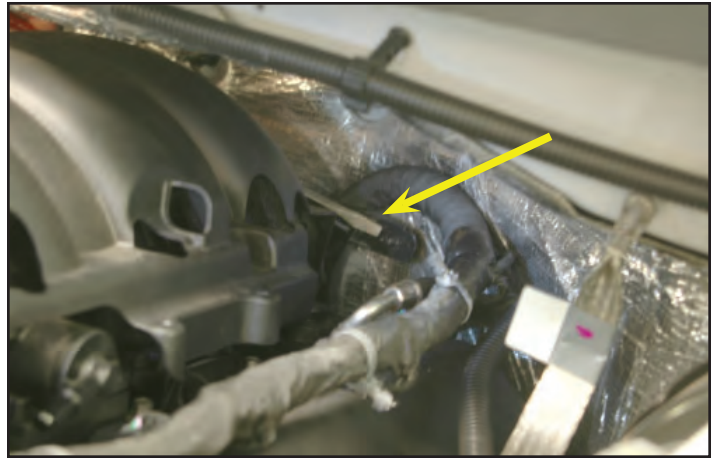

26. This image shows the location of the four tree connectors on the back of the intake manifold.

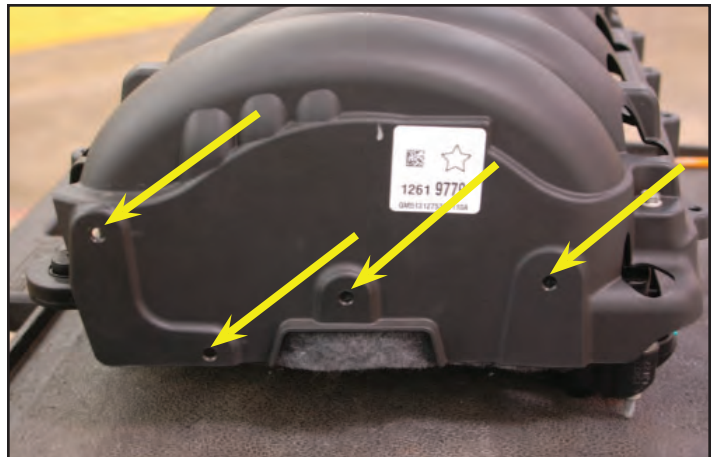

27. Pull the OEM intake manifold out of the vehicle and set aside. Parts will be used from this assembly. Gaskets, and throttle body will be reused.



28. Carefully remove the valley cover foam insulating blanket from the vehicle. This will be reused after trimming in a later step.



29. Use a shop vacuum to clean off the heads being careful to not allow any debris to fall into the exposed intake ports.



30. Use denatured alcohol, lacquer thinner or some other non-petroleum based solvent to wipe the surfaces of the head intake ports.



31. Use tape or clean shop towels to cover over your intake ports. It's important to keep these ports clean and avoid any debris falling into the exposed openings.



Section 3: Removing Fascia/Grille and Install Low Temperature Radiator

32. Remove the twelve push pin rivets from the top of the radiator cover by prying up on the center pin to release the spreaders, then pry up on the outer ring and pull the push pins free. There are two alignment tabs at the front that pull straight up to release. Remove the cover and set aside for later reinstall.



33. **This does not apply to the 2017 or newer Sierra/Silverado.** Remove the front wheel well fender trim from both sides by removing the 6 bolts located around the perimeter.



34. **This does not apply to the 2017 or newer Sierra/Silverado.** In the fender well, use a 7mm wrench to remove the two bolts (on each side of the vehicle) at the front skirt holding the fascia/grille bottom panel to the sub-frame.

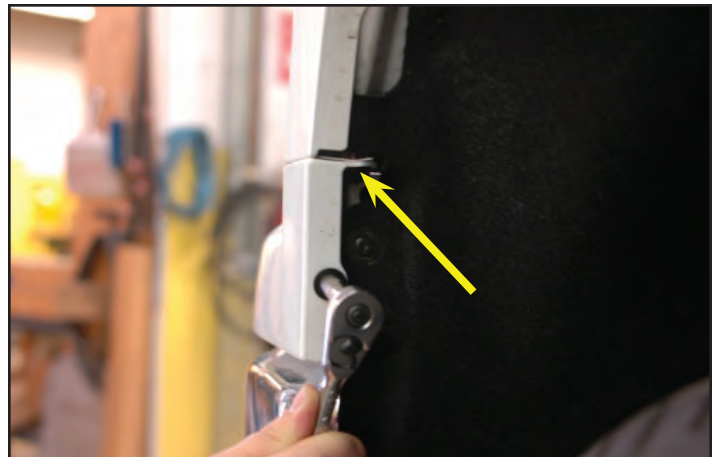

35. **This does not apply to the 2017 or newer Sierra/Silverado.** Carefully pull out on this fascia bottom panel to unsnap it from its location



36. This photo shows the hidden locations for the six clip retainers (shown with yellow arrows) for the fascia bottom panel from the last step. Have an assistant hold the panel while you pry at these six locations to remove the panel. The red arrow locations show the four lower mounting areas for the grille that will be referred to in the next step. (**Red arrow locations are not on the 2017 or newer Sierra/Silverado**).

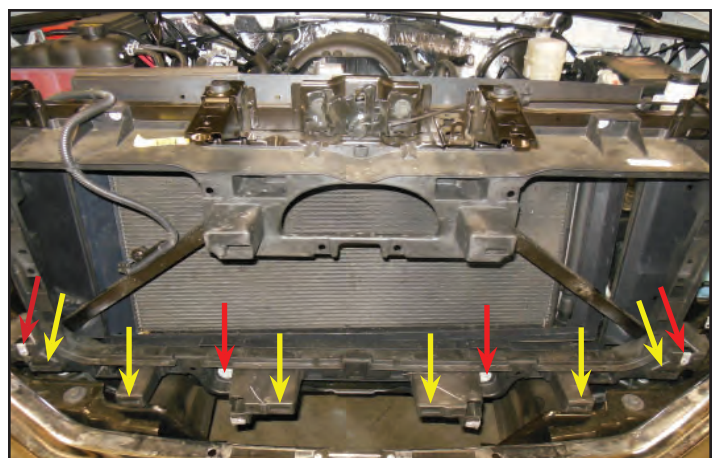

37. Remove the four bolts (shown with arrows) holding the top of the fascia/grille to the sub frame using a 10mm wrench. Also remove the four bolts from the lower portion of the grille that were mentioned in the last step.

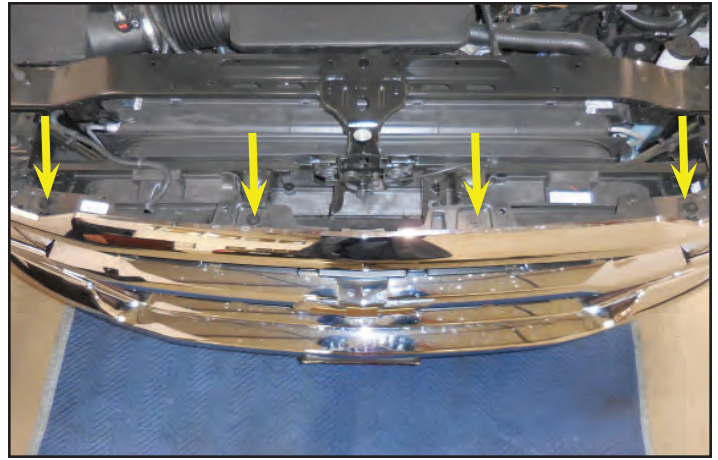

38. Pull straight out on the fascia/grille to disconnect the two remaining snap clips at the center of each side, and the bottom guiding slots. Set the fascia/grille aside carefully for later reinstall.



39. **This does not apply to the 2017 or newer Sierra/Silverado.** Use a 10mm wrench to remove the four headlight mounting bolts on the right side of the vehicle. (This is a photo of a Silverado headlight. The Sierra has the same mounting locations.)



40. **This does not apply to the 2017 or newer Sierra/Silverado.** Lift up carefully on the headlight to separate it from the frame and disconnect the wiring harness plug (shown at the yellow arrow location) by pressing the release tab and pull it free. Set the headlight aside in a safe spot to be reinstalled in a later step. Repeat the removal process on the left side headlight..



41. Remove the two upper radiator mounting bolts using a 13mm socket.

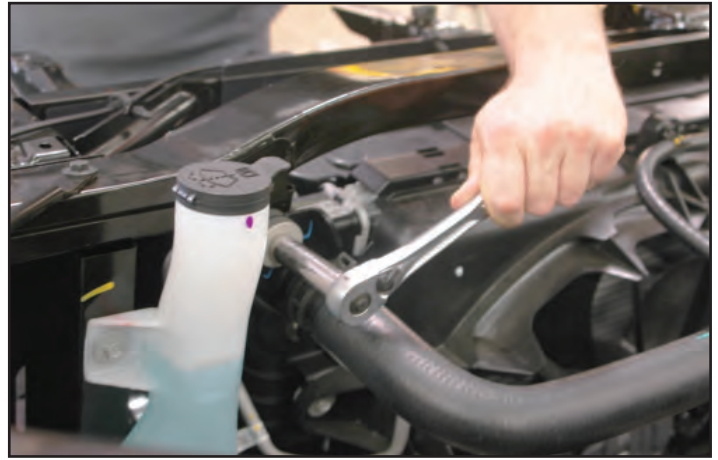

42. Remove the two upper-forward, diagonal fender-brace bars using a 10mm wrench.



43. Disconnect the airbox MAF plug from the airbox on the right side of the vehicle. Pull the "tree" clip from the mounting hole in the airbox disconnecting the harness to the airbox.



44. The hoses going to the radiator overflow tank can be disconnected. This is not absolutely necessary but does make the job a bit easier. Connect the two hoses together using a coupling (hose mender), or plug them with a plug or dowel and tuck out of the way. Again, this is not absolutely necessary.



45. Pull the factory airbox from the vehicle, there are no screws anchoring the airbox in place. Locating pins push through grommets, and a firm pull will disconnect it. Set the airbox aside for installation in a later step.

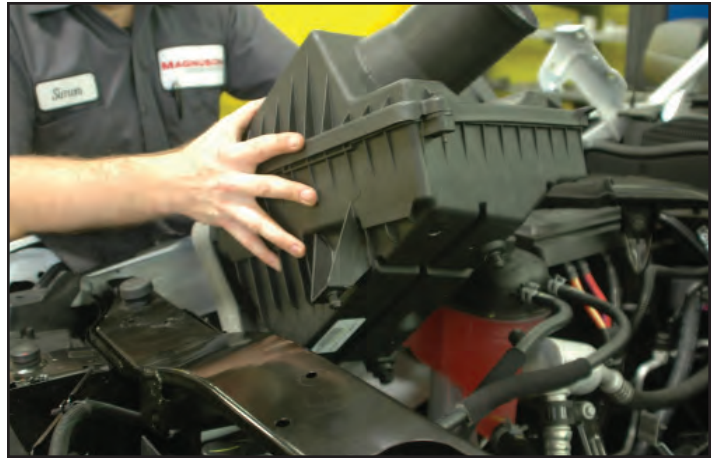

46. Remove the three (each side) upper radiator cross-frame support brace bolts using a 10mm wrench. These are all accessible only from below the support brace. Use a flathead screwdriver or a push rivet removal tool to unsnap the top rivets of the rubber air deflector on the right side to ease access.



47. Remove the cross-frame support brace center bolt using a 13mm wrench.



48. **For 2017 or newer Sierra/Silverado.** The bolt for the window washer reservoir may need to be removed to allow clearance for removing the cross-frame support brace.



49. Pull the cross-frame support brace from the vehicle and set aside for re-install in a later step.



50. Pull up on the upper radiator shroud to unsnap it from the retaining slots, set aside for later re-install.



51. Remove the two retainers holding the hood latch release cable as shown with arrows.

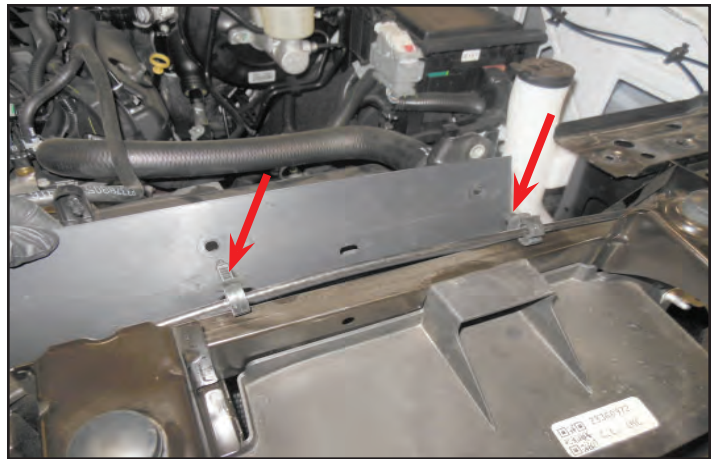

52. Remove the retainer holding the wiring harness shown with an arrow.



53. Remove the plastic push rivets from the plastic panel that is located around the radiator. This is the same shroud that retainer clips were removed from in the last two steps. There are 3 push rivets on top, 2 on each side, and 3 on the bottom. All the rivet heads are hidden from view in this photo. The top and bottom rivets are located on the back sides of this panel.

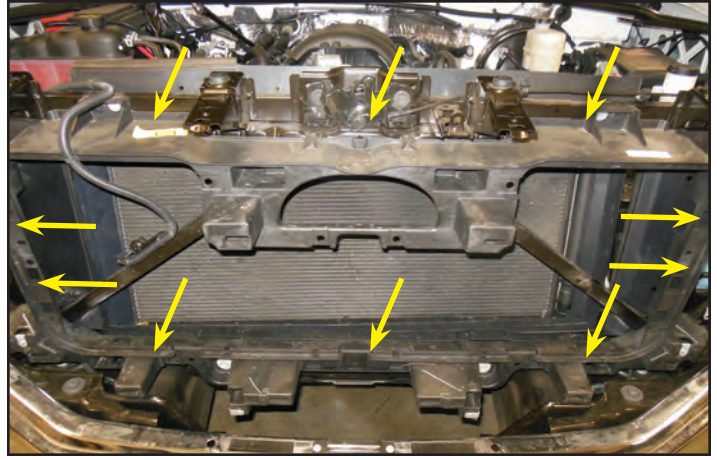

54. Here you can see the three lower locations after the rivets have been removed.



55. Once the rivets have been removed you will have to pull the sides of the panel inward to release them from their locations as you pull upward. Be careful not to damage any radiator fins while you remove this panel.



56. Here you can see the panel from the last step being removed.

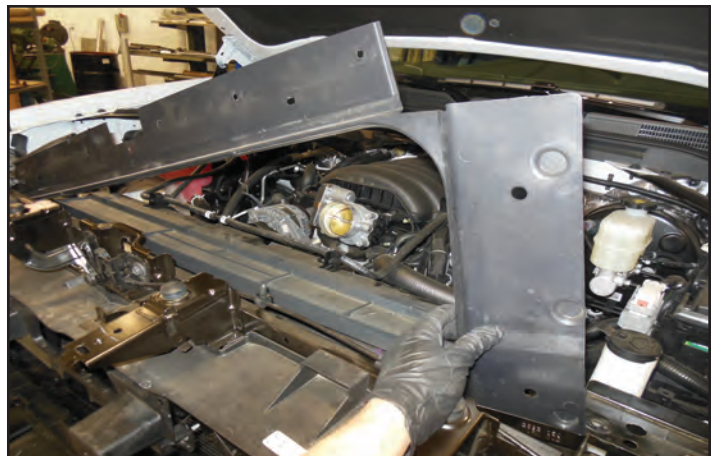

57. Cut out the provided template for your vehicle and install it in the location shown on the panel just removed. **There is a specific template for the Sierra or Silverado.** Use this template to mark the location for the two holes, and cut the holes out using a rotary tool or knife.

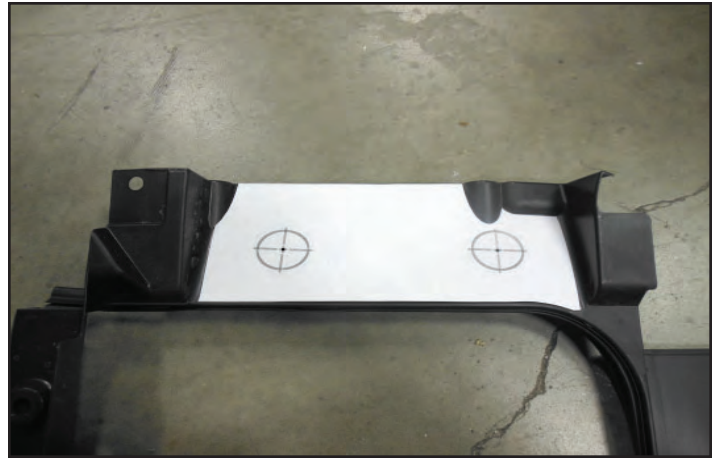

58. Install the two provided grommets at the hole locations. Now re-install the panel back into its original location using the OEM push rivets.



59. Slide the provided low temperature radiator (LTR) assembly into the space created by pushing the radiator assembly top section toward the rear of the vehicle. The mounting brackets should be pointing forward, the hose barbs on the right side of the vehicle. Be careful to not damage the existing radiator or the LTR.

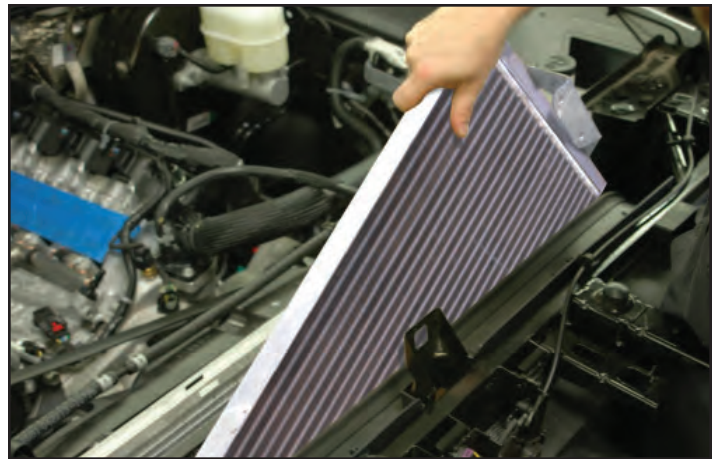

60. Install the provided grommets in the channel holes on the provided LTR mounting bracket.

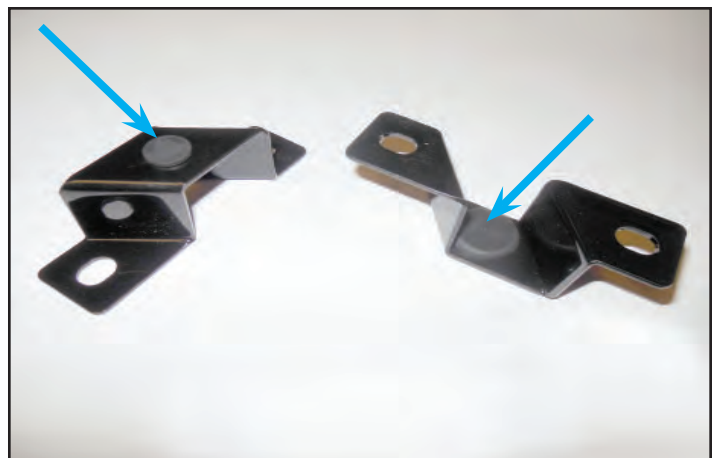

61. The LTR should now be resting on the bottom tray forward of the radiator. Center the unit and use the mounting bracket holes to align and place the mounting brackets on the “A-Frame” in front of the radiator.

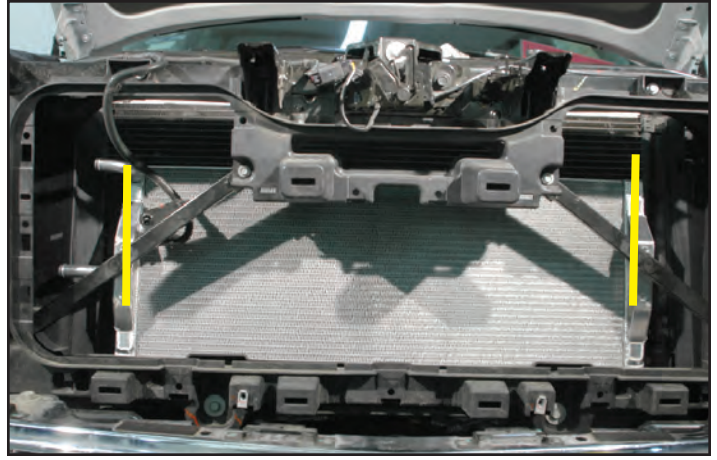

62. Attach the mounting brackets to the LTR mounting flange using the supplied bolts and a 12mm wrench. **Do not tighten until you have aligned the LTR to be level, cross checking against the existing horizontal lines of the radiator.** Secure in place when you’ve got proper alignment.

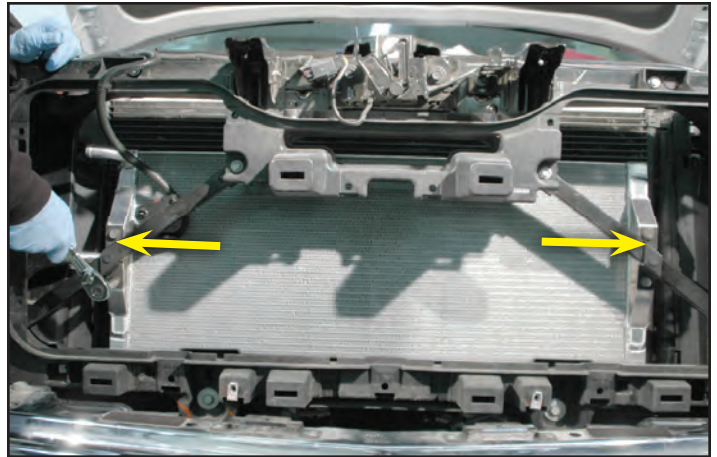

63. Replace the upper radiator shroud by snapping into place.



64. Replace the upper radiator cross-frame brace and secure with the OEM mounting bolts.



65. Replace the upper radiator mounting bolts and vibration dampers.



Section 4: Initial Plumbing and Intercooler Pump Install for Heat Exchanger

66. Attach the supplied reservoir mounting bracket to the reservoir with the provided bolts and secure using a 10mm wrench.



67. Remove the two nuts holding the master cylinder to the brake booster canister using a 15mm socket.

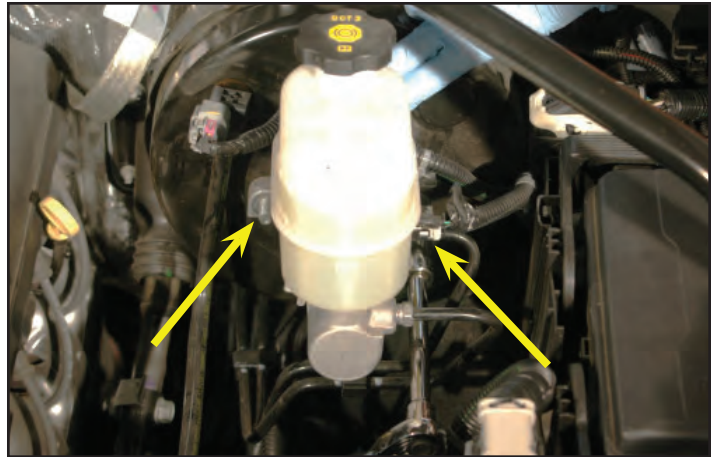

68. Replace the nuts incorporating the reservoir assembly. **Torque to 25 ft-lbs.** Verify your torque wrench settings.



69. **This step applies only to 2014-15 trucks.** Use a 13mm wrench to remove the bolt shown with the green arrow, and pry out the push pin rivet shown with the yellow arrow to remove the plastic splash shield on the left hand side frame rail by the bumper support bracket, directly below the ECM. This will not be reused.

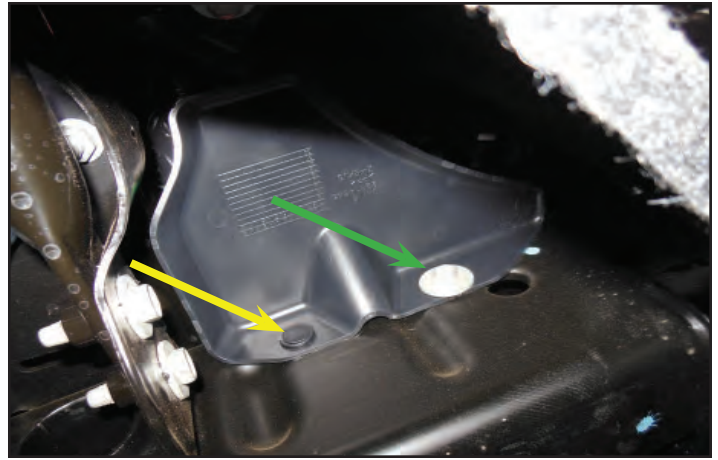

70. **This step applies only to 2014-15 trucks.** Use a 15mm socket to remove the right hand side mounting bolt on the left hand side bumper support bracket at the frame, adjacent to the plastic guard just removed. Loosen the left hand side bolt on the same bumper support bracket.

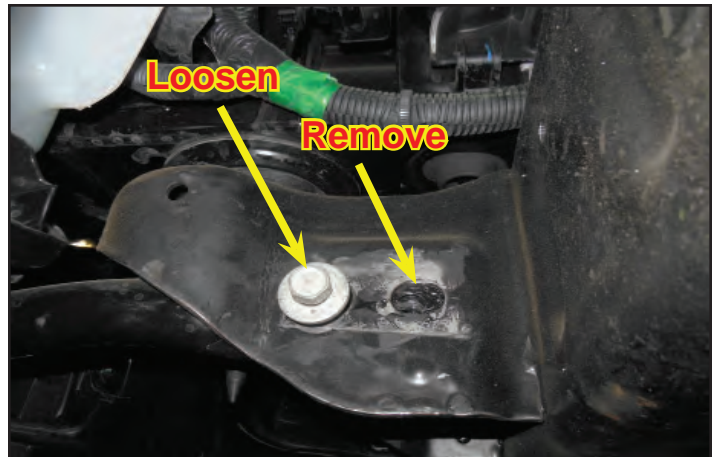

71. **This step applies only to 2014-15 trucks.** Disconnect the wiring harness mounting clip from the hole on the top of the frame rail above the bumper mounting bracket, and below the computer.



72. **This step applies only to 2014-15 trucks.** Use a provided zip tie to anchor the harness to the existing black brake hard line, which runs parallel to the frame rail.

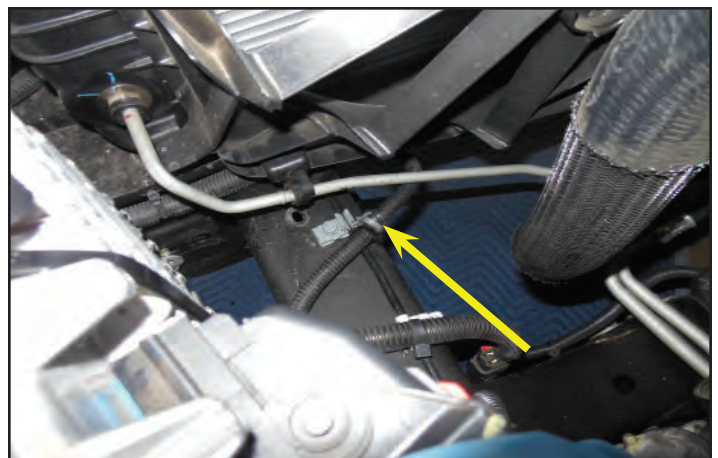

73. This step applies only to 2014-15 trucks.

Use a 12mm socket to mount the intercooler pump to the supplied bracket as shown. The discharge barb of the pump should be perpendicular to the bracket mount. The base of the pump should be flush with the rear Adel clamp.



74. This step applies only to 2014-15 trucks.

Engage the slot of the pump bracket on the loosened bolt of the bumper support bracket on the frame rail. Replace the removed bolt incorporating the remaining hole of the intercooler pump mounting bracket. The pump discharge barb should be above the frame rail pointing to the right hand side of the vehicle. Secure the bolts using a 15mm wrench.



75. This step applies only to 2016 and newer trucks.

Install the provided intercooler pump bracket shown on the left side inner frame rail using the provided bolt (shown with a yellow arrow) in the OEM threaded hole. The metal tab will line up with the hole shown with the green arrow to maintain proper alignment.

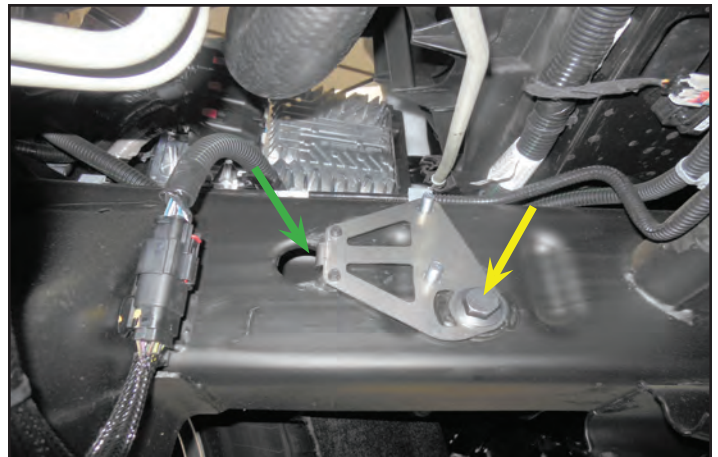

76. This step applies only to 2016 and newer trucks.

Install the intercooler pump with the two Adel clamps using the two stud locations on the bracket installed in the last step (shown with red arrows) and the provided nuts. The output barb of the intercooler pump will be facing towards the right side of the truck as shown with the blue arrow.

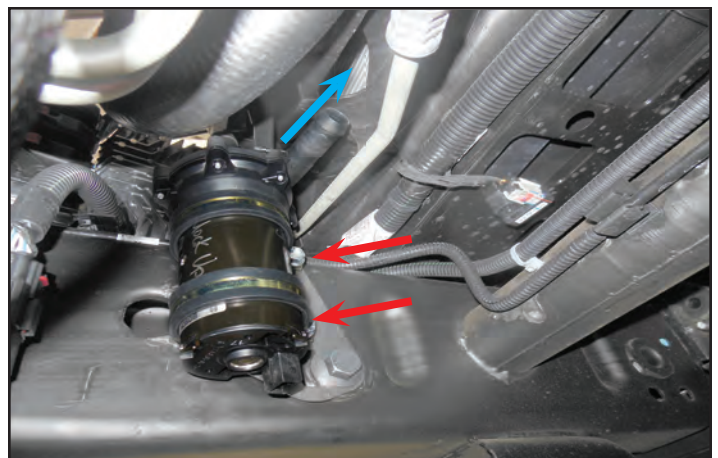

77. Refer to the expanded diagram at the end of the instruction manual to prepare your intercooler system plumbing hoses for install. When measuring the mesh sleeve make sure it is in a relaxed state.

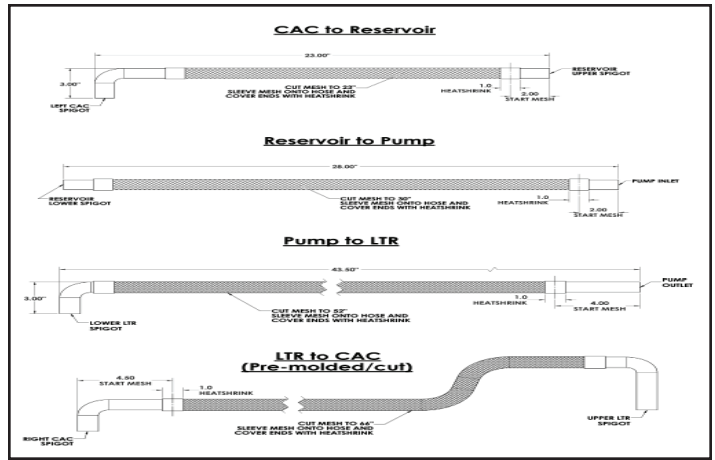

78. Connect one end of the “Reservoir to Pump” inlet hose to the reservoir using a provided worm gear clamp. It’s important to utilize only worm gear clamps on the reservoir.



79. Route the other end of the hose from the last step forward and down to connect to the intercooler pump inlet hose barb using a provided wide band spring clamp.

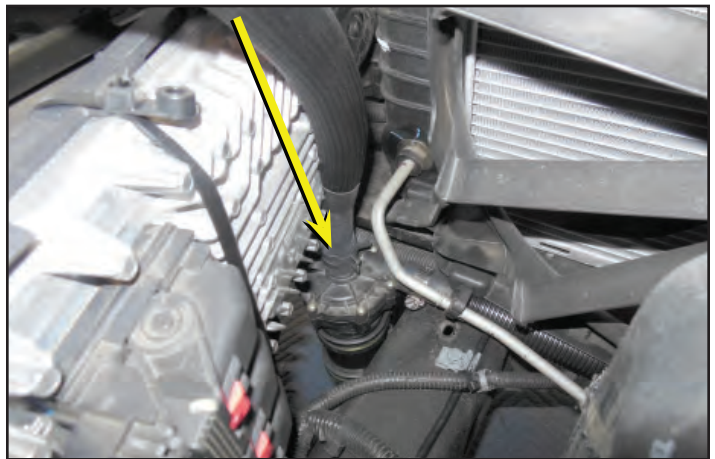

Section 5: Removing Drive Belt and Preparing Supercharger

80. Take the OEM insulator removed earlier, and cut away sections highlighted in yellow. Refer to the next three steps for detailed information related to cutting the insulator.

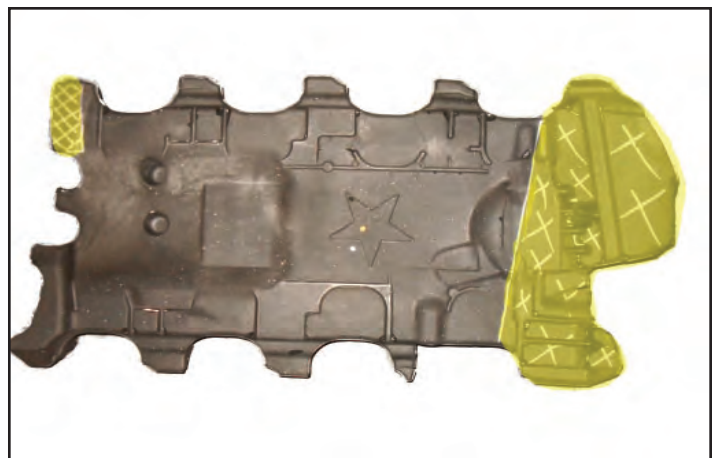

81. Cut away the entire portion of the corner shown with cross-hashed lines in left hand.



82. Undercut the portion to the right before cutting out.



83. Trimmed insulator shown.

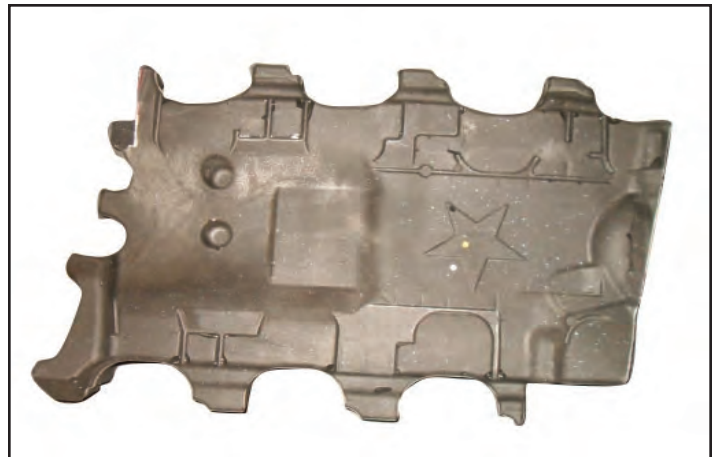

84. Install trimmed insulator from last step into manifold valley.



85. Remove the OEM drive belt by springing the tensioner using a ½” breaker bar or socket wrench. If necessary utilize a piece of pipe to extend the lever length. This belt will NOT be reused.

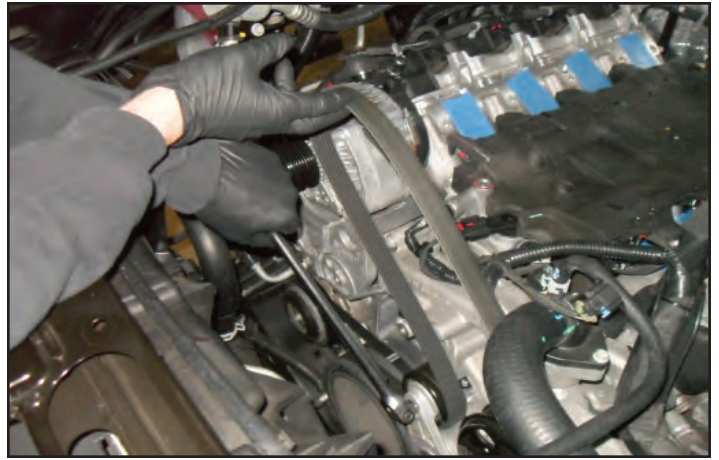

86. Remove the left alternator mounting bolt shown using a 15mm wrench.



87. Loosen the other alternator support bolt shown.



88. **This does not apply to the 2017 or newer Sierra/Silverado.** Remove the bracket located next to the alternator it will be re-attached later.



89. Pry the alternator up to rotate it out of the way.



90. Alternator shown rotated out of the way.



91. **Use the diagram at the back of this manual to identify the following hoses.** Connect the short leg of the cut/assembled “CAC to Reservoir” elbow hose to the left side charge air cooler hose barb at the back of the supercharger assembly. Secure in place with a provided wide band spring clamp. Connect the cut/assembled “LTR to CAC” elbow hose to the right side charge air cooler hose barb at the back of the supercharger assembly. Secure in place with a provided wide band spring clamp. The hoses route toward their respective sides as shown.

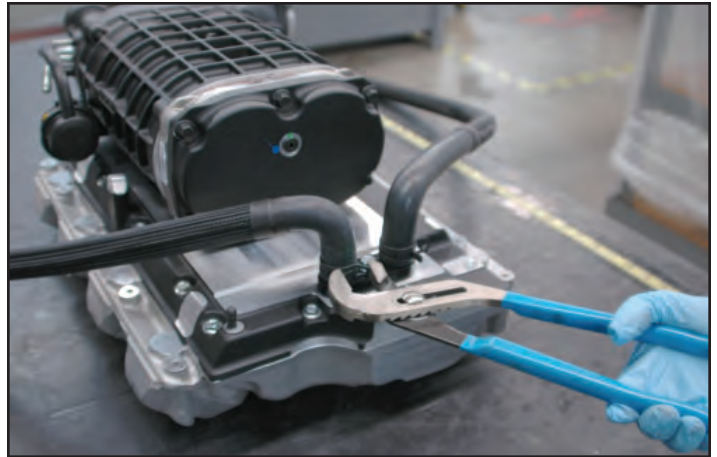

92. Remove the throttle body from the OEM intake manifold using a 10mm wrench. These four fasteners will not be reused.

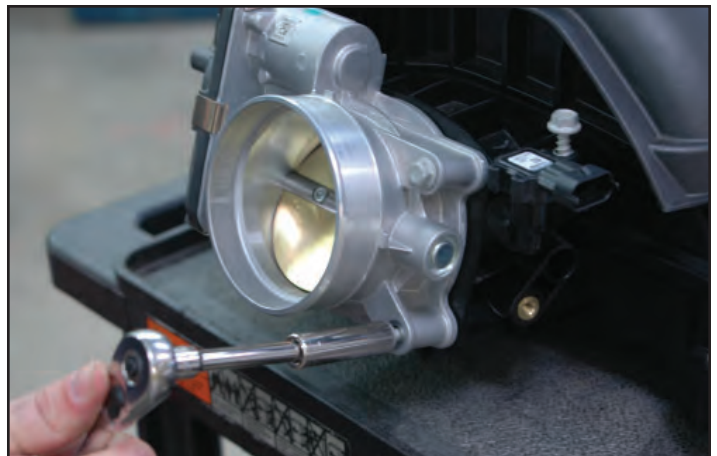

93. Remove the OEM throttle body gasket from the OEM intake manifold. Inspect for damage and clean as necessary. If you have a 5.3L engine this gasket will be re-used.



94. Install the throttle body adaptor plate, and **torque to 106 in-lbs**. Install the throttle body gasket removed earlier in the groove of the supercharger inlet. If the throttle body adaptor provided has a gasket you will not need to use the old one.



95. Install the OEM throttle body on the supercharger inlet using a 10mm wrench and **torque to 106 in-lbs** using the supplied 40mm long M6 fasteners.



96. You should have the 3 parts shown to the right. (A) IAT sensor, (B) crush washer and (C) MAF/IAT breakout. To complete the installation of the sensor you will need a 19mm (or ¾") deep socket and a torque wrench capable of 175in-lbs (~15ft-lbs).

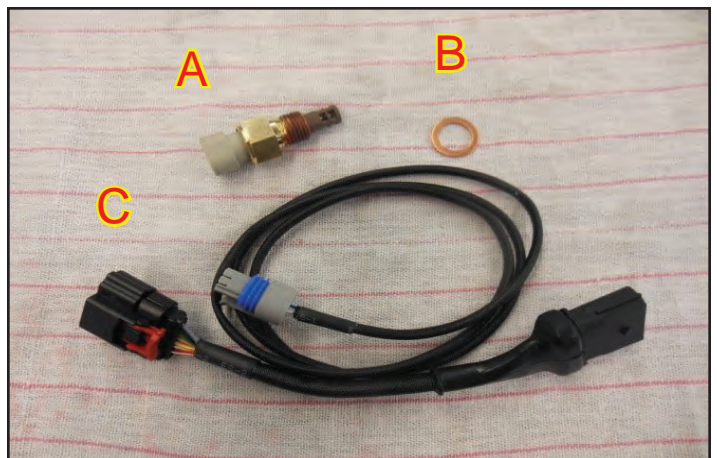

97. Prior to installing the supercharger, you will need to install the IAT sensor at the location shown with an arrow. Once the sensor is installed, be careful not to set the supercharger on a flat surface directly over the IAT sensor. **The plastic connector sits below the surface of the runners and can be damaged if subjected to the weight of the supercharger.** It is best to perform this installation on a bench and let the front of the supercharger hang over the edge slightly so the sensor will not get crushed.

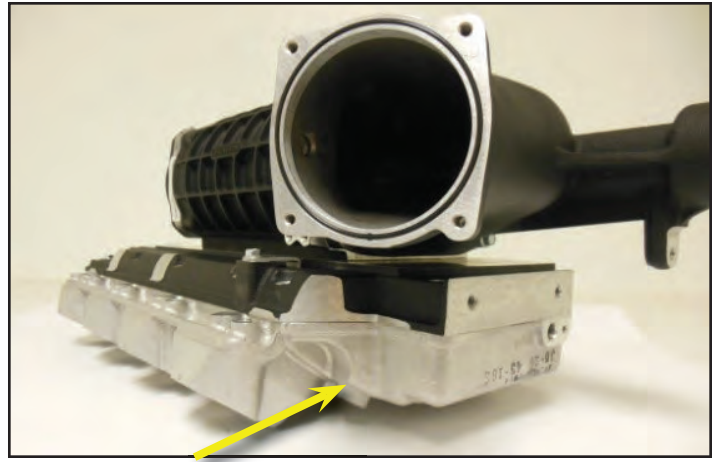

98. It is very critical that the crush washer sits between the brass sensor housing and the aluminum manifold. This will ensure there is an air tight seal between the sensor and manifold. Begin by placing the crush washer over the brass threads on the IAT sensor; then thread the sensor into the manifold by hand until snug.



99. Once the sensor is snug to the crush washer use a 19mm (or $\frac{3}{4}$ ") deep socket attached to your torque wrench and **torque to 175in-lbs (~15ft-lbs).**

***Note: Take care when installing the sensor into your socket so it does not get damaged. When flipping the supercharger right side up be careful not to crush the sensor.**



Section 6: Install Supercharger

100. **This step is not necessary for TVS1900 Installation.** At the back firewall you will need to remove a 3.5" x 7" section of insulation. This area has been highlighted in green. On the upper right side of the highlighted area you can see that the cut starts just past the radius.

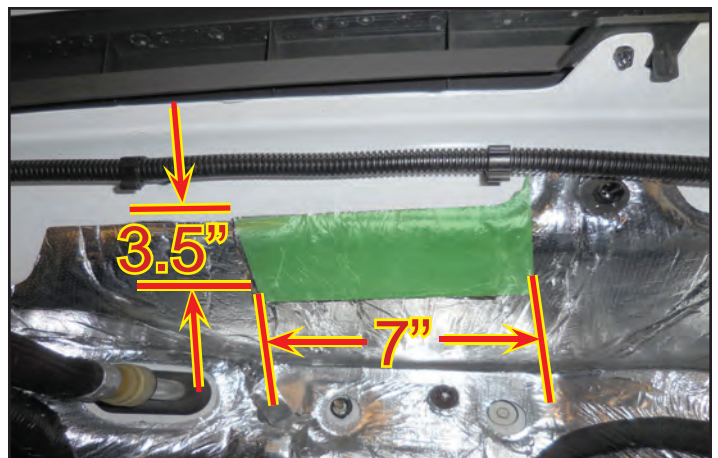

101. Here is a photo of the insulation after it has been modified. Also at this time you may find it helpful to temporarily detach the two clips holding the wiring harness at the locations shown with the arrows here to provide more clearance for the supercharger installation. You can replace these two clips once the supercharger is installed.

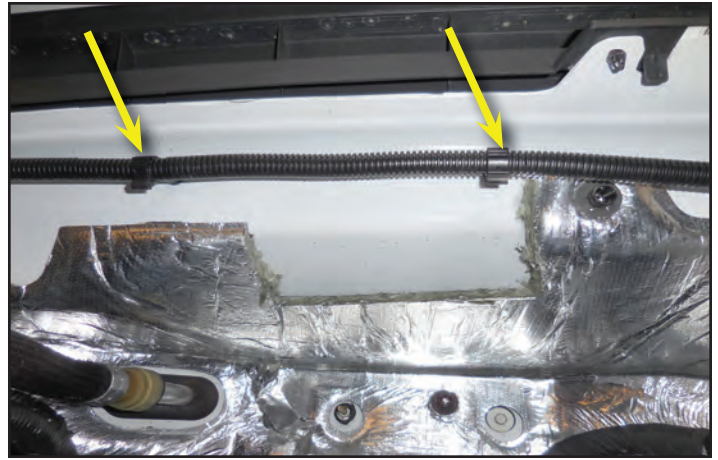

102. Remove the factory EVAP hose from behind the left side cylinder. Squeeze the connector clip to release the clip and pull free.

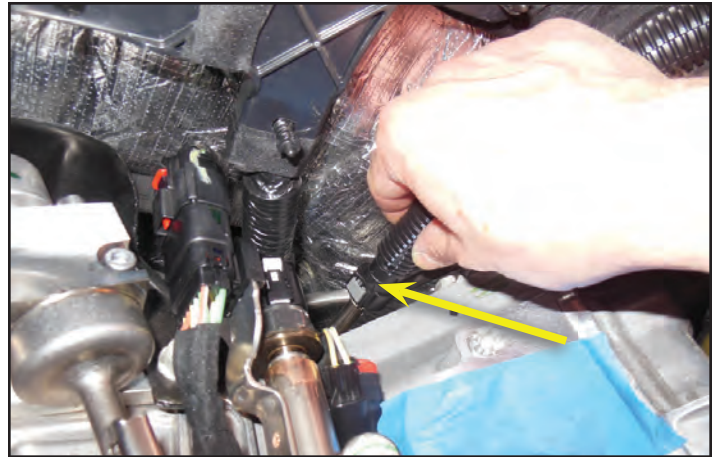

103. Connect the gray end of the new provided EVAP hose shown to the location where the factory EVAP hose was just removed (shown with a yellow arrow). Remove the bolt holding the fuel injection line in place (shown with a green arrow) to allow clearance while the supercharger is being installed. This bolt will be reinstalled after the supercharger is mounted.



104. Remove the tape or rags covering the intake ports on the heads. Be careful not to allow any debris to fall into the exposed ports.



105. Wipe intake port sealing surfaces clean with lacquer thinner, alcohol, or some other non-petroleum based solvent.



106. Clean the OEM gaskets removed from the intake manifold earlier, and install them in the grooves on the bottom of the supercharger intake manifold (one of eight shown here at the yellow arrow location). If you find any damaged gaskets you will need to replace them with GM replacement parts. The tab will line up with the slot on the outside edge.

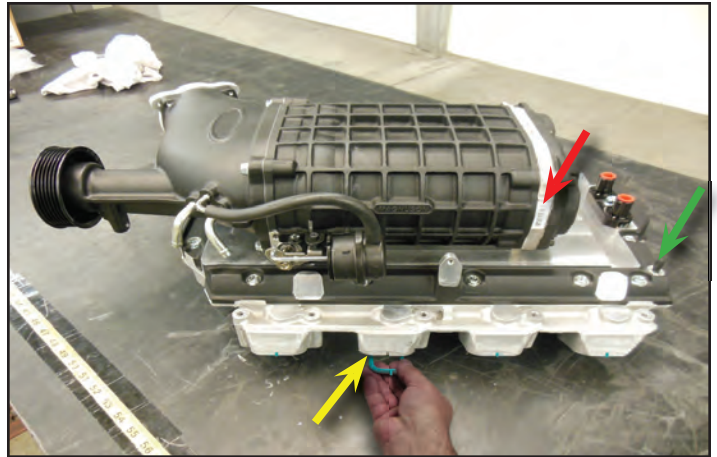

Also note that the serial number is shown at the red arrow location and the boost reference port is at the green arrow location.

107. Spray a thin film of non-petroleum based lubricant, such as silicone spray or mild dishwashing detergent, on the port mounting surfaces to facilitate aligning and with the help of an assistant, carefully place the supercharger assembly into position.



108. **Apply blue Loctite 242 to the ten provided 75mm long supercharger mounting bolts.** Install supercharger mounting bolts and **torque in position to 106 in-lbs** using a 10mm wrench. Follow the torque order given at the back of the book. At this point also reinstall the bolt holding the fuel injection line to the left side of the engine that was removed earlier.



109. Plug the IAT end of the MAF/IAT breakout harness into the sensor.

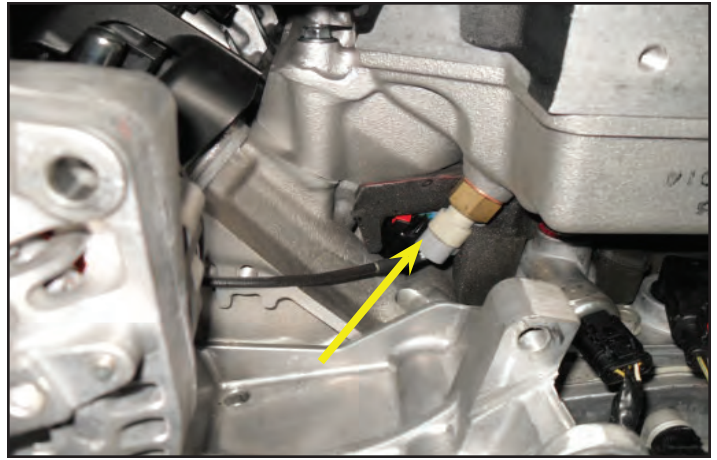

110. Mount the provided Idler pulley with the side showing in the photo facing outwards away from the engine using the provided bolt as shown in the next steps.



Section 7: Install Drive Belt, Finish Plumbing/Wiring of Intercooler System

111. Rotate the alternator back to its original position. Place the supplied idler pulley on the idler standoff. Install the supplied idler standoff assembly with the supplied new bolt into the left alternator mount (shown with an arrow). **Torque the bolt to 25 ft.-lbs. NOTE: Due to casting variances, there are shims supplied. Once the vehicle is running it may be necessary to shim the idler pulley so it is centered on the belt.**



112. **Torque the other alternator bolt to 25 ft.-lbs.** Re-attach the bracket adjacent to the bolt just torqued. **The bracket is not on the 2017 or newer Sierra/Silverado.**



113. Install the provided accessory drive belt using the drive belt routing diagram. A larger diagram is included at the back of this book.

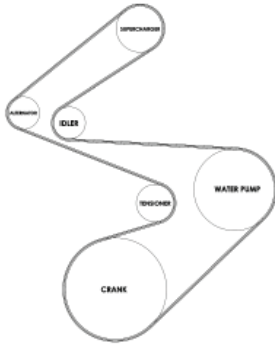

114. Connect the left side hose coming from the supercharger charge air cooler to the upper-rear hose barb on the intercooler reservoir using a provided worm gear clamp. It's important to utilize only worm gear clamps on the charge air cooler reservoir.



115. Route the hose from the right hand side of the charge air cooler forward, down, and route it through the upper hole made in the plastic near the radiator as shown with the yellow arrow.

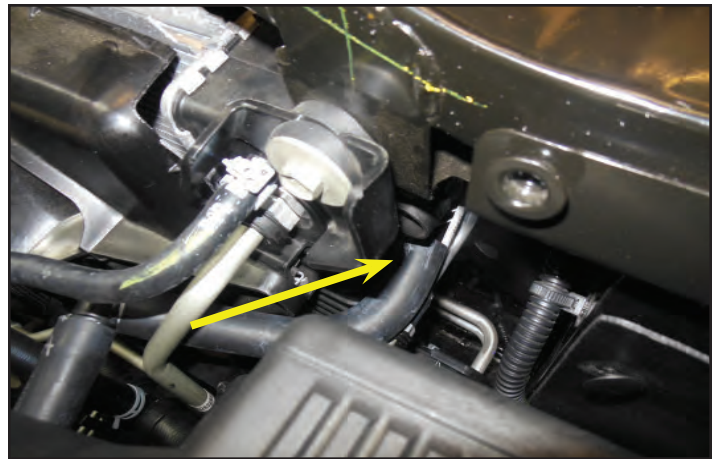

116. Connect the hose from the last step that came from the right side of the charge air cooler to the upper LTR barb and secure with a wide band spring clamp. Secure the hose along its path with a few provided zip-ties.



117. Gather the provided cable tie with clip attached. Remove the clip shown in the next step.

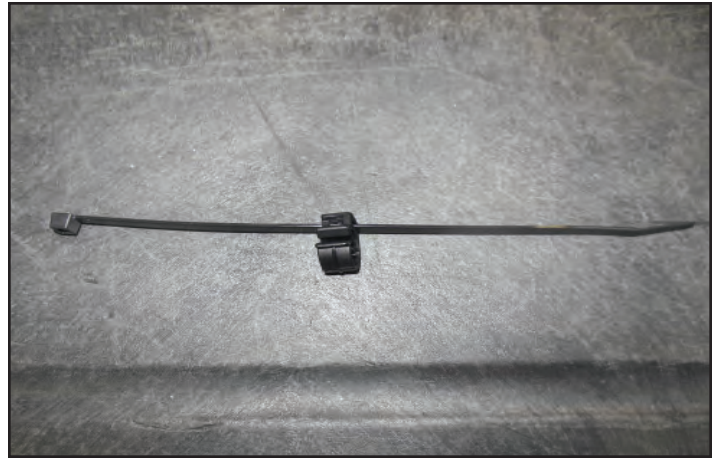

118. Remove the two tabs (highlighted in green) from the plastic clip.



119. Here you can see the two tabs on the left that have been removed from the clamp on the right. Reinstall this clip onto the cable tie.

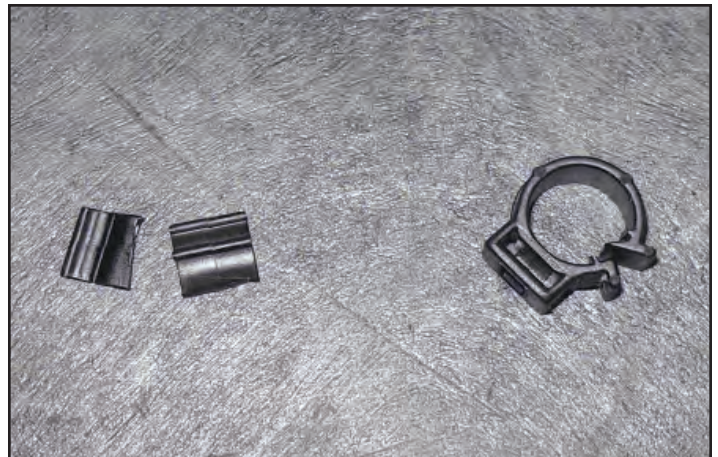

120. Install the plastic clamp from the last step around the oil cooler line (shown with an arrow) and wrap the cable tie around the hose going to the upper LTR barb. Do not overtighten the cable tie.



121. Slide the long straight section of the “Pump to Lower LTR” hose through the space shown with the arrow. This will be routed to the output of the pump.

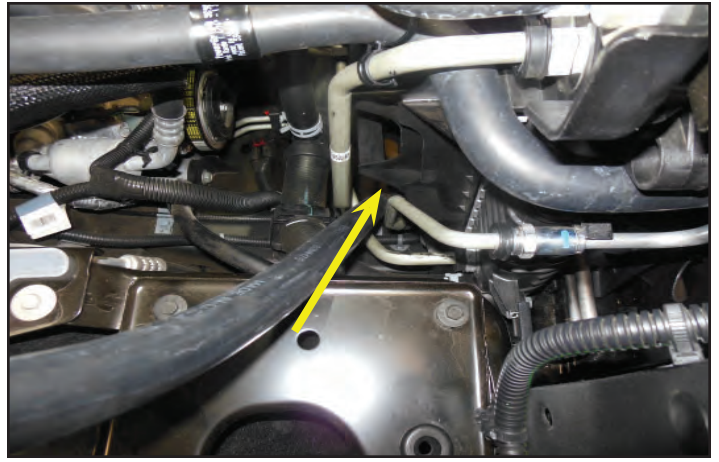

122. Route the end of the “Pump to Lower LTR” hose with the 90° bend through the hole made in the plastic cover earlier (shown with an arrow).

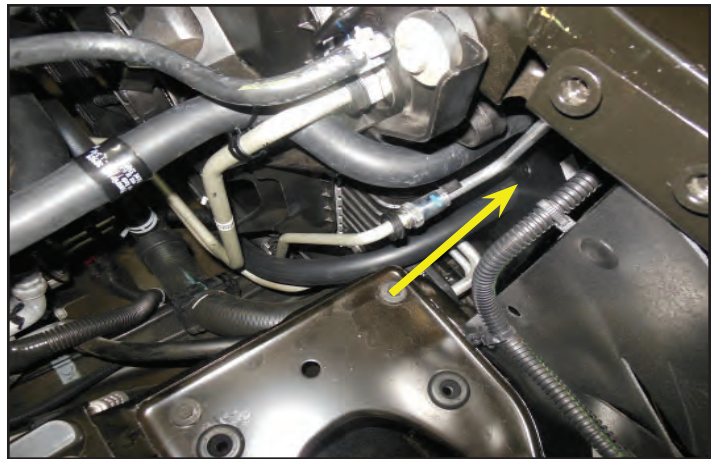

123. Connect the hose from the last step to the lower LTR barb and secure in place with a provided wide band spring clamp.



124. This view is from under the vehicle looking to the left front. Run the opposite end of the “Pump to Lower LTR” hose behind the lower portion of the radiator as shown and secure in place with provide cable ties as shown with the arrow.

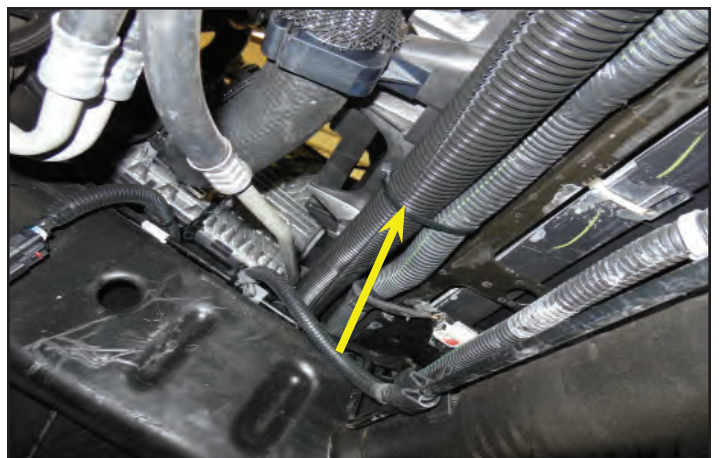

125. Install the end of the “Pump to Lower LTR” hose to the output side of the intercooler pump and secure in place with a provided worm gear clamp.

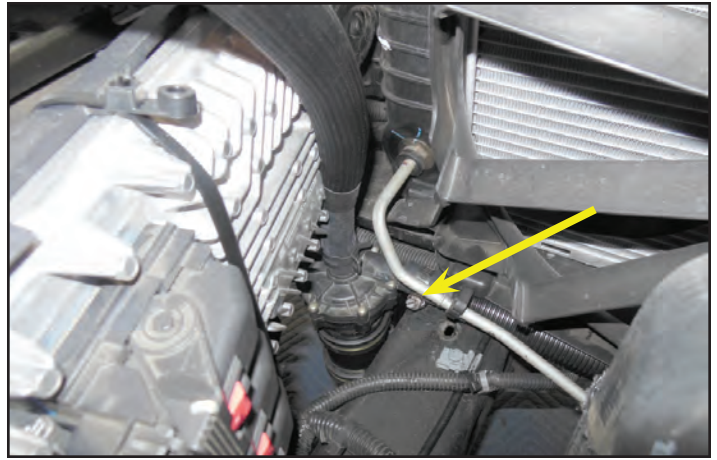

126. Install the provided fuse in the charge air cooler pump wiring harness fuse holder, and replace the cap.



127. To install your intercooler pump harness bracket, begin by removing the two nuts with a 13mm socket where the left hand inner fender meets the firewall. This will be behind the fuse center, below the hood hinge. Place the supplied pump harness bracket onto the studs and use the factory nuts to secure it in place.



128. Place the relay on the stud closest to the firewall and secure with a supplied 6mm nut, using a 10mm socket. Use the remaining supplied 6mm nut to secure the fuse holder to the bracket. Make sure to route the wires to the fuse holder as shown, so that they do not rub on the sheet metal below.

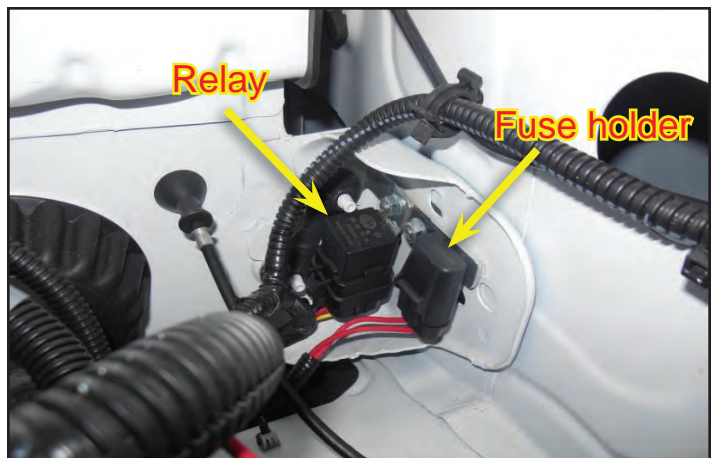

129. Route the plug from the wiring harness down to the inside of the fuse center, along the existing wiring harness and plug into the intercooler pump connector.



130. Secure the pump harness to the existing harness using the provided cable ties.



131. Remove the fuse center cover by pressing the release tabs and lifting up.

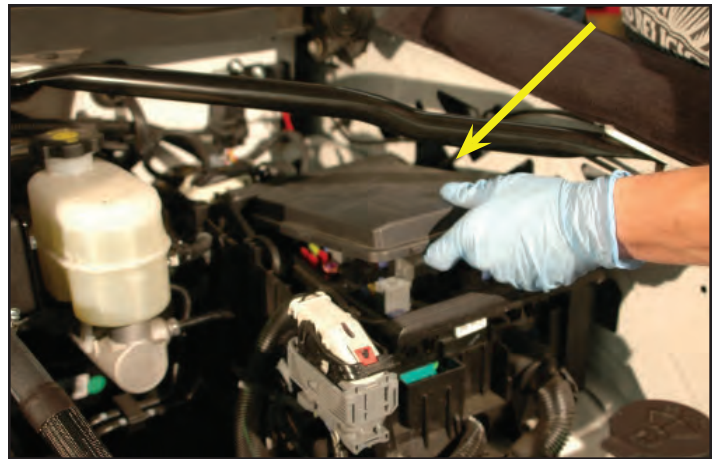

132. Cut a small slot in the back lip of the fuse center tray as shown.



133. Remove the fuse number 3A (labeled: MISC IGN) from the slot in the fuse center. The fuse number may not be the same on your vehicle, but you should be able to find the fuse labeled MISC IGN.

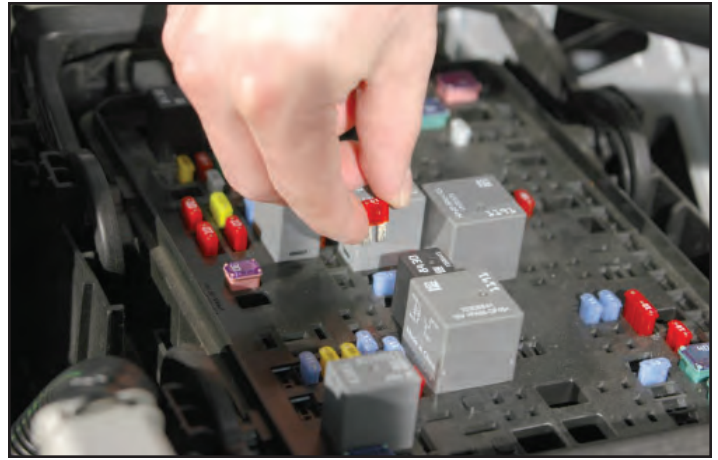

134. Connect the fuse tap end of the yellow wire from the intercooler wiring harness to one leg of the fuse just removed.

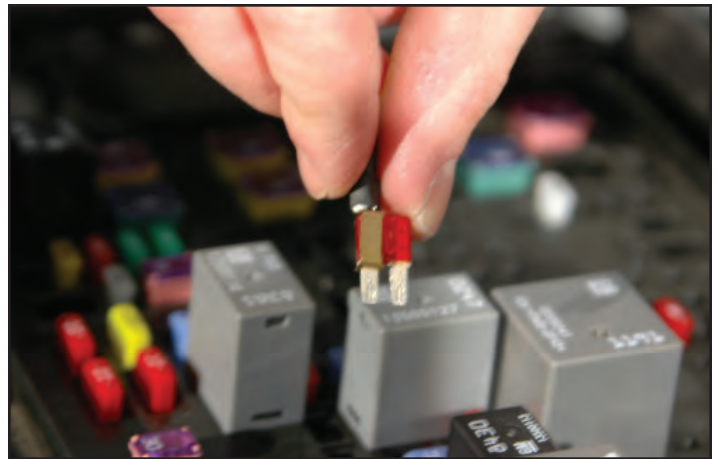

135. Replace the fuse in slot number 3A (labeled: MISC IGN) with the fuse tap installed on one leg.

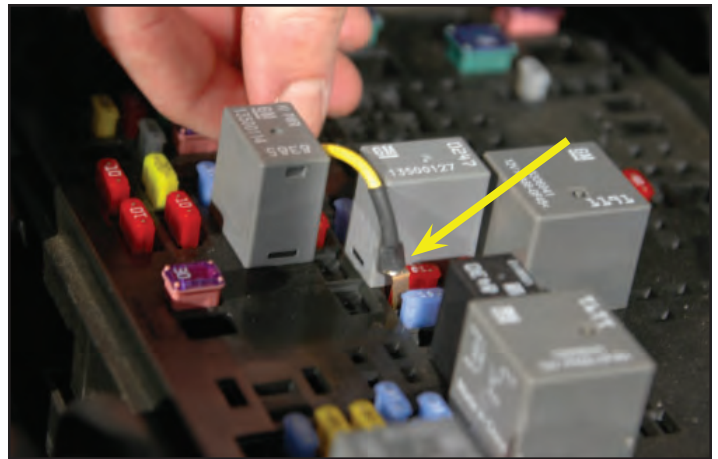

136. Press the yellow wire down into the slot you created earlier.



137. Replace the cover on the fuse center engaging the snaps. The lid should NOT be crimping down on the yellow wire.



138. Remove the nut of the hot lead at the back of the fuse center using a 12mm wrench. Replace the nut incorporating the eyelet terminal on the red wire from the intercooler wiring harness.

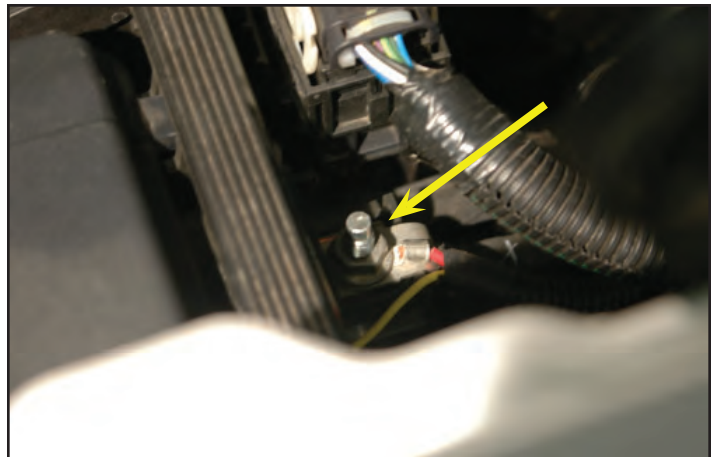

139. **For 2017 or newer Sierra/Silverado.** There is a cover over the hot lead that will have to be trimmed on the 2017 or newer Sierra/Silverado. Trim the green highlighted section out.

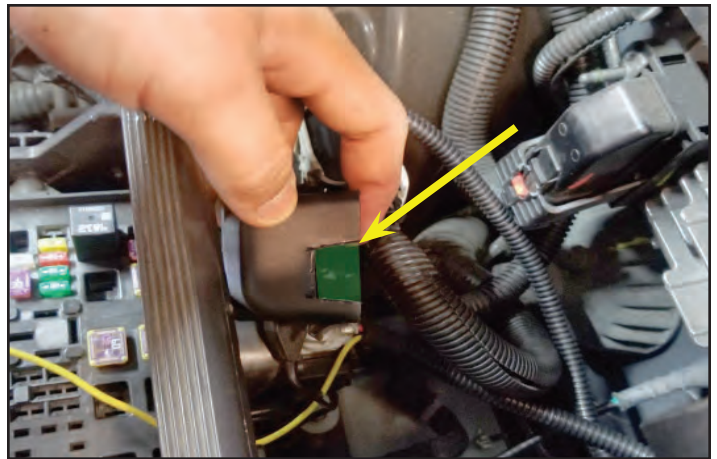

140. Connect the black ground wire eyelet terminal to the existing grounding bolt at the firewall on the left hand side, just above and inside the brake booster canister.

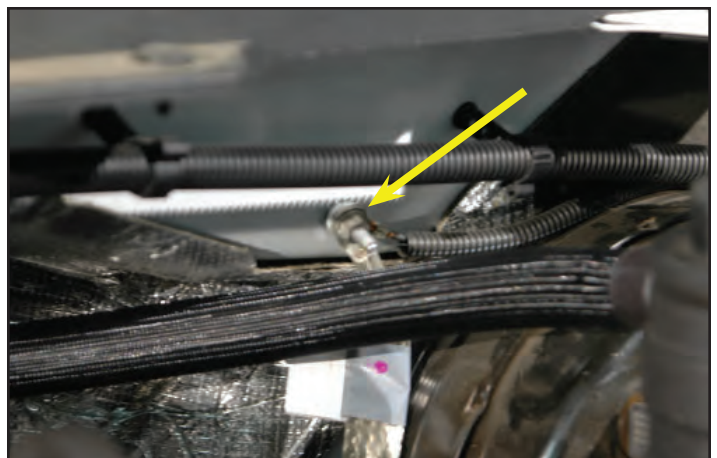

Section 8: Install Air Quality Control and System Monitoring Devices

141. Connect the factory EVAP plug to the provided EVAP extension/breakout harness connector on the left hand side of the engine.

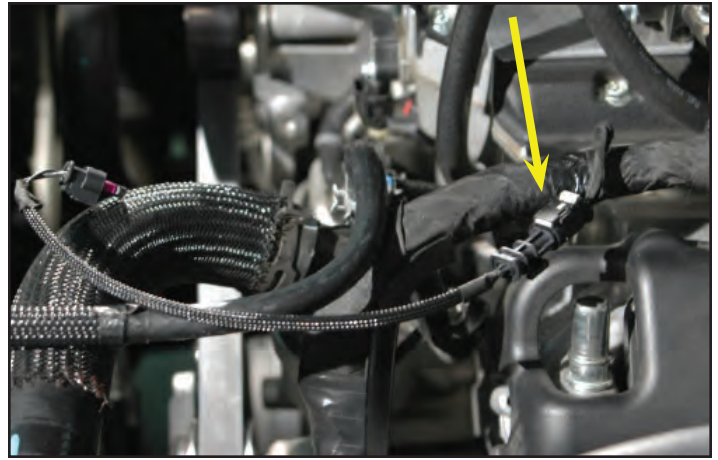

142. Mount the OEM EVAP solenoid to the provided mounting bracket using the factory mounting bolt and provided spacer using a 10mm wrench as shown. The washer may not be on original bolt. **Add blue Loctite 242 to bolt before installing. The black spacer should sit between the solenoid and bracket.**



143. Mount the EVAP solenoid mounting bracket to the left side boss on the supercharger lid using the provided 16mm long bolt and secure in place with a 10mm wrench. **Torque to 106 in-lbs.**

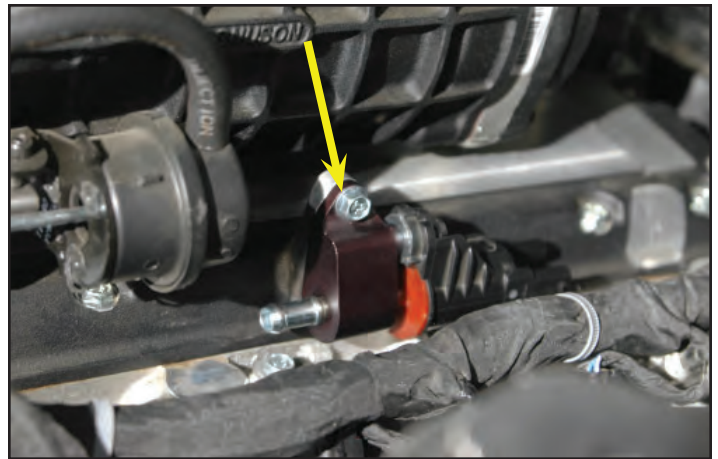

144. Connect the extended EVAP solenoid plug to the EVAP sensor. Secure the extension harness to the coil pack harness with a few of the provided zip-ties.



145. Connect the provided 10" x 3/8" PCV hose between the EVAP solenoid and the supercharger inlet hose barb. No clamps are required. If necessary adjust the hose length to prevent rubbing on supercharger bolt head.

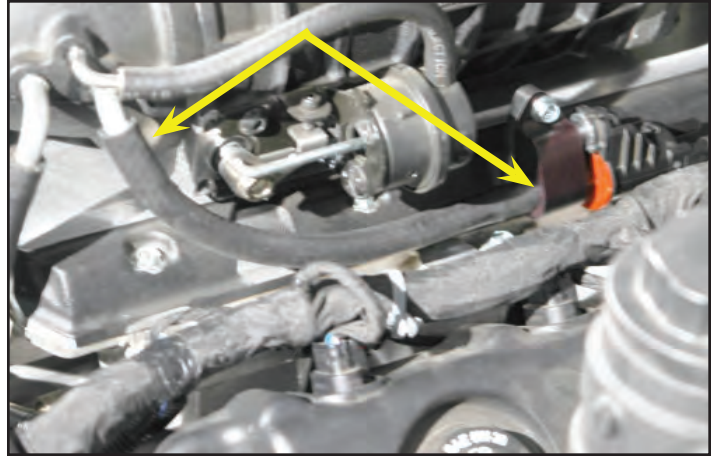

146. Connect the opposite end of the supplied EVAP hose, that was connected to the rear of the left hand side head where the factory hose was removed earlier, to the EVAP solenoid where shown with the arrow. The yellow locking clip end goes to the solenoid, and the gray locking clip end goes behind the cylinder head. Ensure that both "click" into locking position.



147. Connect the factory MAP sensor plug to the connector on the MAP sensor.

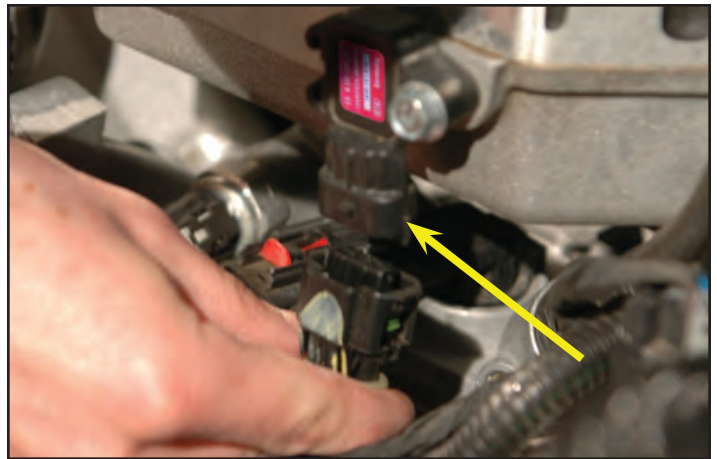

148. Connect the throttle body plug to the throttle body. Connect the alternator wire plug to the receptacle on the alternator. Some tape removal on the harness may be needed to allow the connection between throttle body, and alternator.

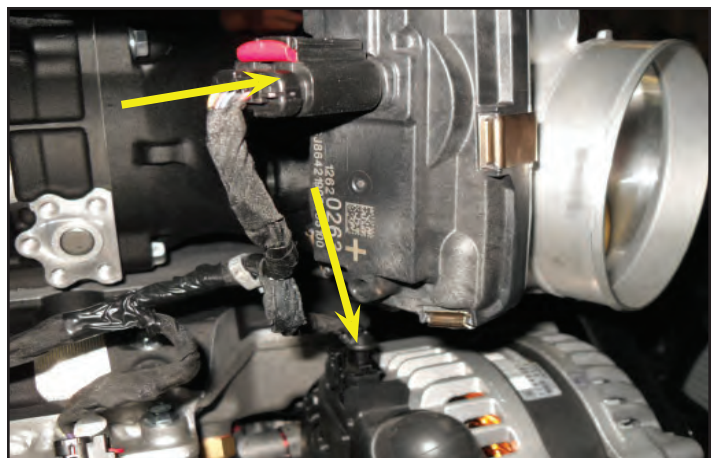

149. Replace the factory air box by pressing into position until the unit snaps in place.



150. Route the MAF/IAT breakout harness behind the alternator. Make sure the harness will not get pinched by the alternator. Use a tie wrap to secure the harness to the factory heater hose as shown by the red arrow to the left.

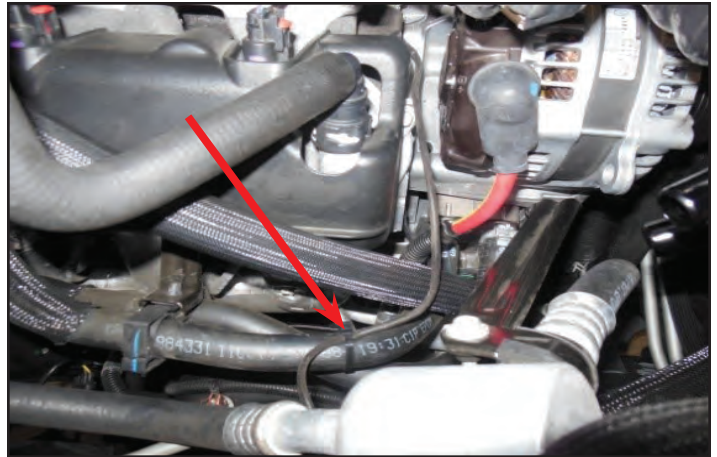

151. Continue to pass the MAF/IAT breakout harness to the right underneath the AC line. Secure the MAF/IAT breakout harness with another tie wrap to the factory MAF harness as shown by the red arrow to the right. ***Note: The green arrow is a reference to the tie wrap installed in the previous step.**

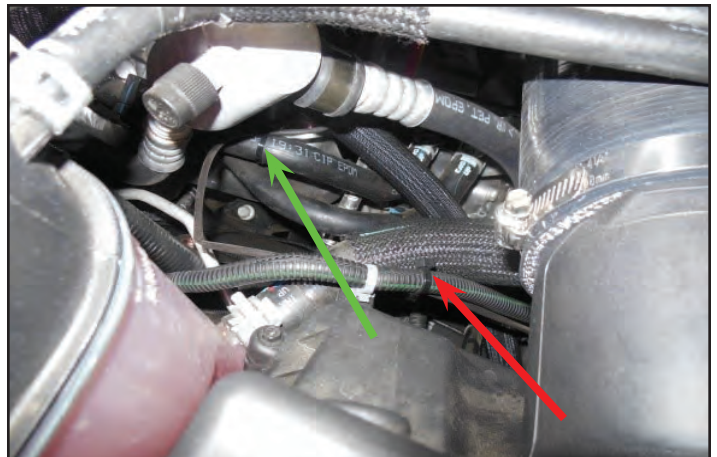

152. Pass the MAF/IAT breakout harness underneath the MAF tube of the air box lid. Disconnect the factory MAF harness from the sensor in the air box lid and connect the male end of the provided MAF/IAT breakout harness to it. You can now plug the female end of the provided MAF/IAT breakout into the factory MAF sensor. Ensure that all connections have clicked into place, and slide the red locking tab(s) back into place. Use two more tie wraps to secure the MAF/IAT breakout as shown by the red arrows to the left.

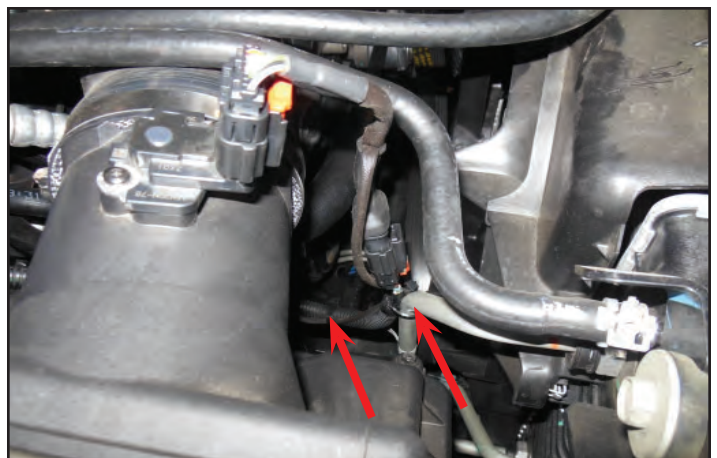

153. Push the wire loom mounting “tree” back into the hole on the back side flange of the air box.



154. Clean up your wiring adding zip-ties as needed to secure the wiring.



155. Connect the provided PCV hose with the blue colored quick connect locking pin between the existing valley cover hose barb on the left side and forward supercharger inlet hose barb.

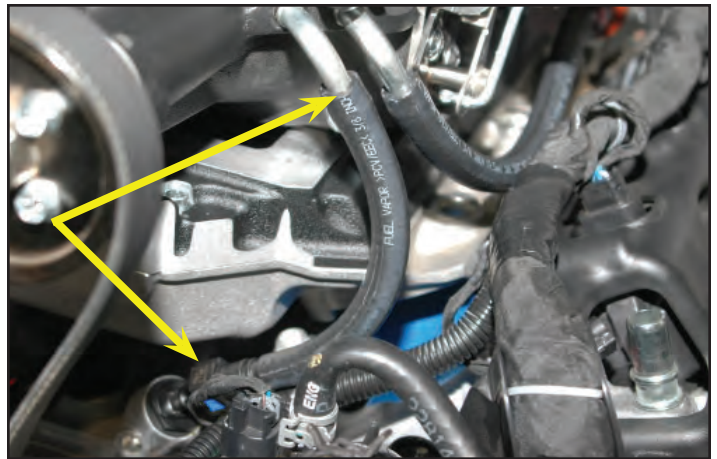

156. Push the two provided zip-tie “tree” connectors into the two bolt holes in the front of the supercharger intake manifold. The flat part of the connector should be pointing up.



157. Slide the provided 8" section of split loom over the PCV hose and anchor in place at each end using two 1" pieces of the provided heat shrink as shown. The opposite side of this hose will be connected in the next step.



158. Connect the 90° hose barb on the uncovered side of the PCV hose to the left hand side front of the valve cover hose barb. Route the hose under the supercharger inlet toward the right hand side of the vehicle. The split loom covered section of the hose should be on the right hand side above the alternator.



159. Anchor the PCV hose to the front of the supercharger intake manifold using the installed zip-tie tree mounts.

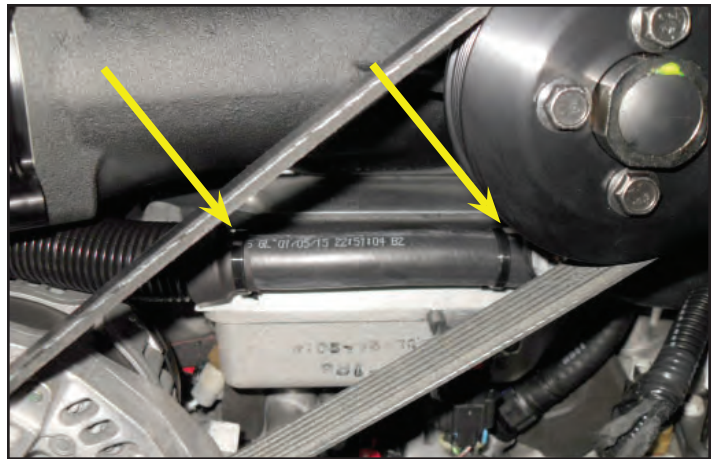

160. Gather the rubber duct shown. Loosen hose clamps to prepare for install. The left side clamp will be taken off completely to install over throttle body.



161. Install the rubber duct from previous step on the air box. Apply Lubriplate grease to the side near the throttle body to help it slide better.

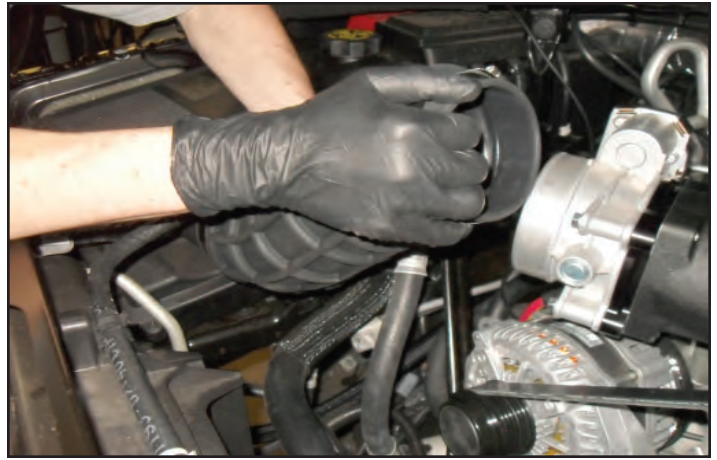

162. Install rubber duct onto throttle body side, and install hose clamp around connection. Make sure duct tabs line up with throttle body indicated with arrow.



163. Tighten the hose clamps on both sides.



164. Connect the free end of the PCV hose from the left hand side front valve cover hose barb onto the lower hose barb of the air tube (Indicated with a blue arrow). Connect the provided 90° PCV hose between the hose barb on the right hand side front of the valve cover and the remaining upper hose barb of the air tube as shown.

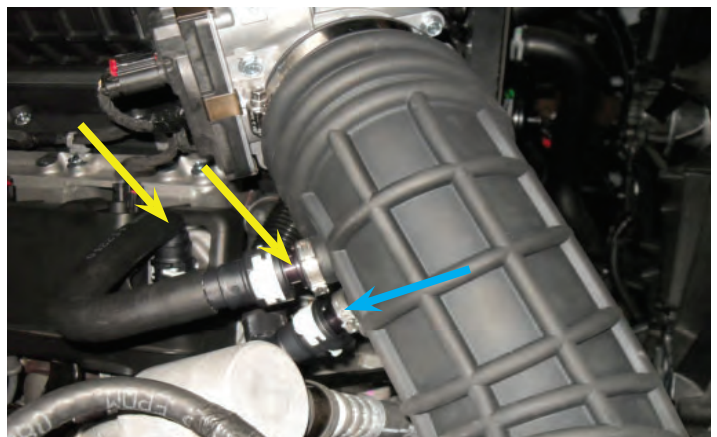

165. If you disconnected the reservoir overflow hoses earlier, reconnect using the OEM clamps. Ensure that you remove any plugs that you may have installed on these hoses.



166. Re-connect the battery negative terminal using a 10mm socket wrench.



Make sure that you have followed step #1 in this manual to load the proper supercharger calibration to your vehicle's ECM.



167. Fill the intercooler reservoir with the vehicle manufacturer recommended coolant mixture. Have an assistant temporarily key the vehicle on to turn the pump on. **Do not start the engine!** Key vehicle off after 5 seconds. Fill reservoir full again and continue this process until fluid is circulating. Fill the reservoir to the top of the upper barb. At this time check engine and supercharger for any leaks.



Section 9: Install Fascia/Grille and Finalizing Installation

168. Reconnect the harness plugs to the headlights removed earlier and replace the headlights using the OEM fasteners.



169. Replace the fascia/grille in position and push on the center of each side grille opening to reconnect the two snap clips, and the bottom guiding slots.

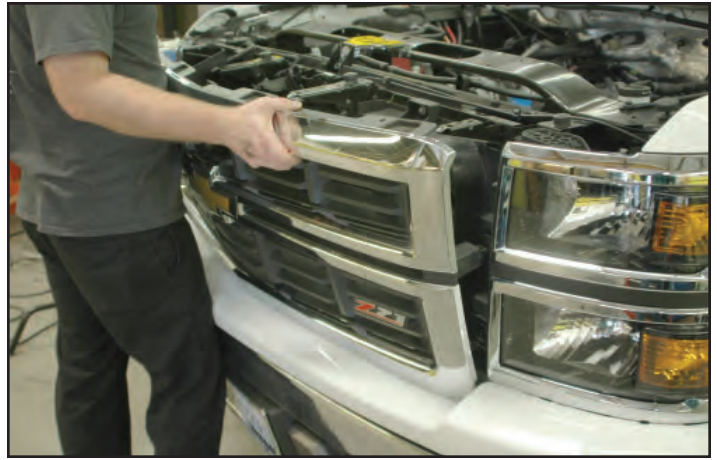

170. Replace the four bolts holding the top of the fascia/grille to the sub frame and the four bolts on the underside of the grille using a 10mm wrench.



171. Carefully push in on the fascia bottom panels to snap the retaining clips into position.



172. In the fender wells, use a 7mm wrench to replace the two bolts (on each side of the vehicle) at the front skirt holding the fascia/grille bottom panel to the sub-frame.



173. Replace the twelve push pin rivets in the top of the radiator cover by pushing the outside ring of the rivets in position and then push center pin down to spread the locking tabs.



Vehicle Testing

Start the vehicle for 5 seconds and shut off, once again check for fuel leaks and fan-supercharger belt alignment. You may need to shim the idler that you installed to center it on the belt. Check radiator and charge air cooler reservoir and top off as necessary.

Test drive vehicle for the first few miles under normal driving conditions. **Do not perform any wide open throttle runs.** Listen for any noises, vibrations, engine misfire or anything that does not seem normal. The supercharger does have a slight whining noise under boost conditions, which is normal. Check & bleed charge air cooler reservoir as needed.

After the initial test drive gradually work the vehicle to wide open throttle runs, listen for any engine detonation (pinging). If engine detonation is present let up on the throttle immediately. Most detonation is caused by low octane gasoline still in the tank.

If you have questions about your vehicles performance, please check with your installation facility.

After you finish your installation and road test your vehicle, please fill out the warranty registration. This can be found on our website.

Hose Cut Assembly Guide

CAC to Reservoir

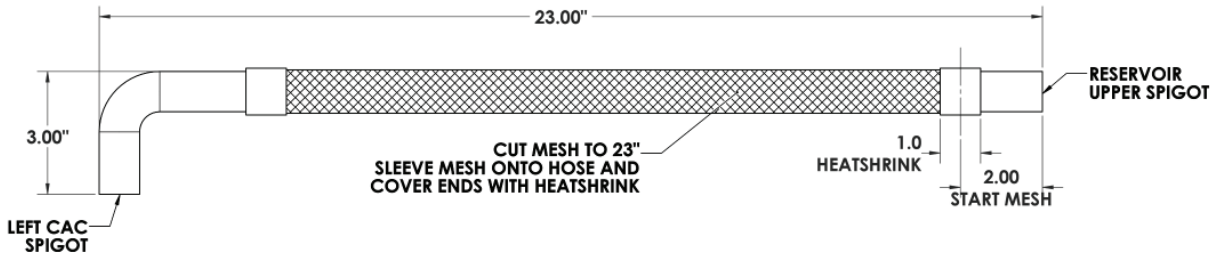

Reservoir to Pump

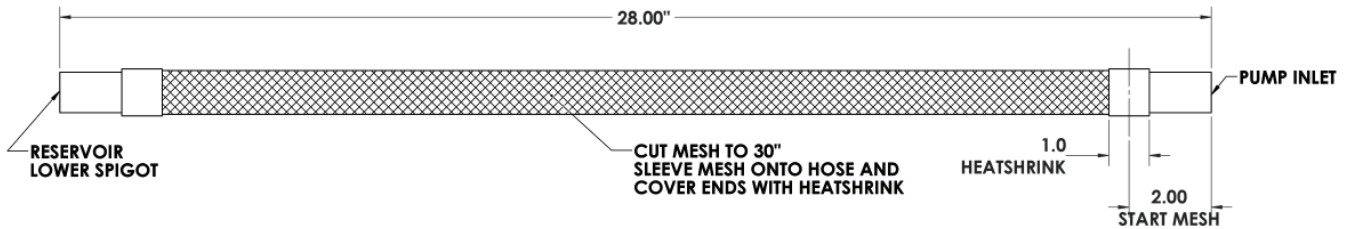

Pump to LTR

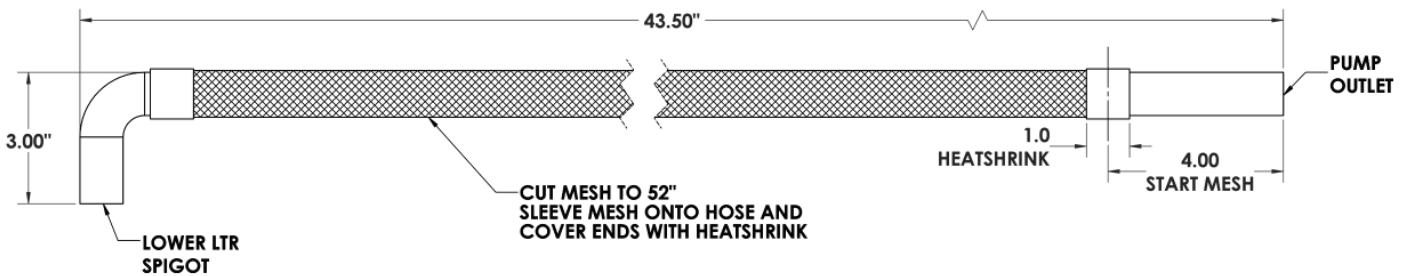

LTR to CAC (Pre-molded/cut)

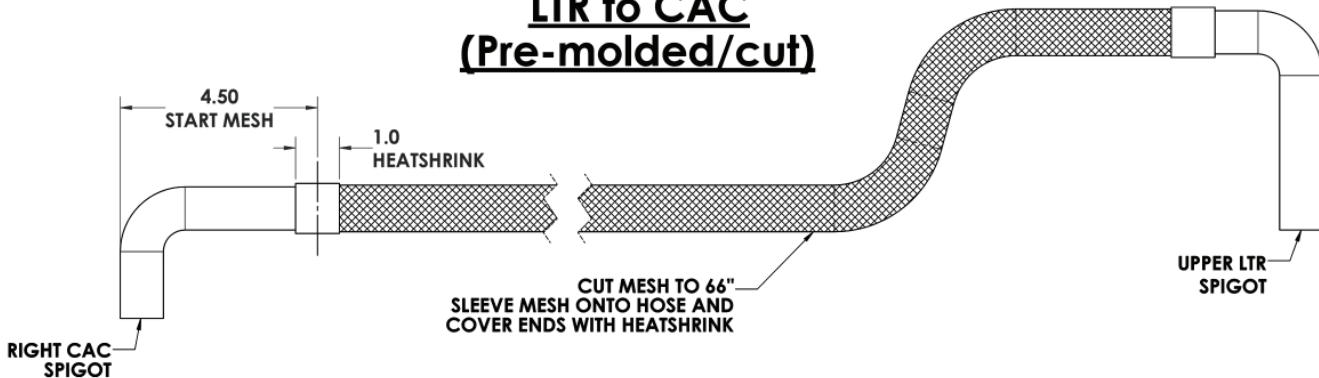

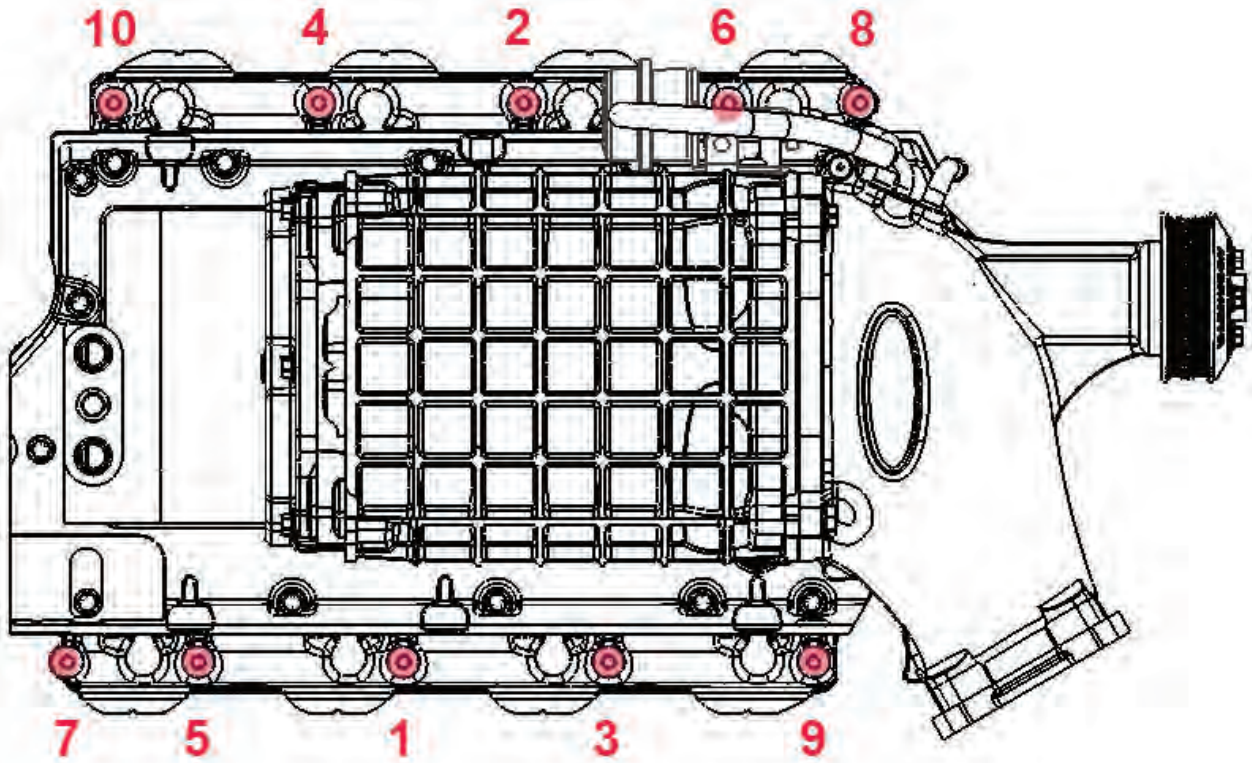

Supercharger Torque
Order Diagram

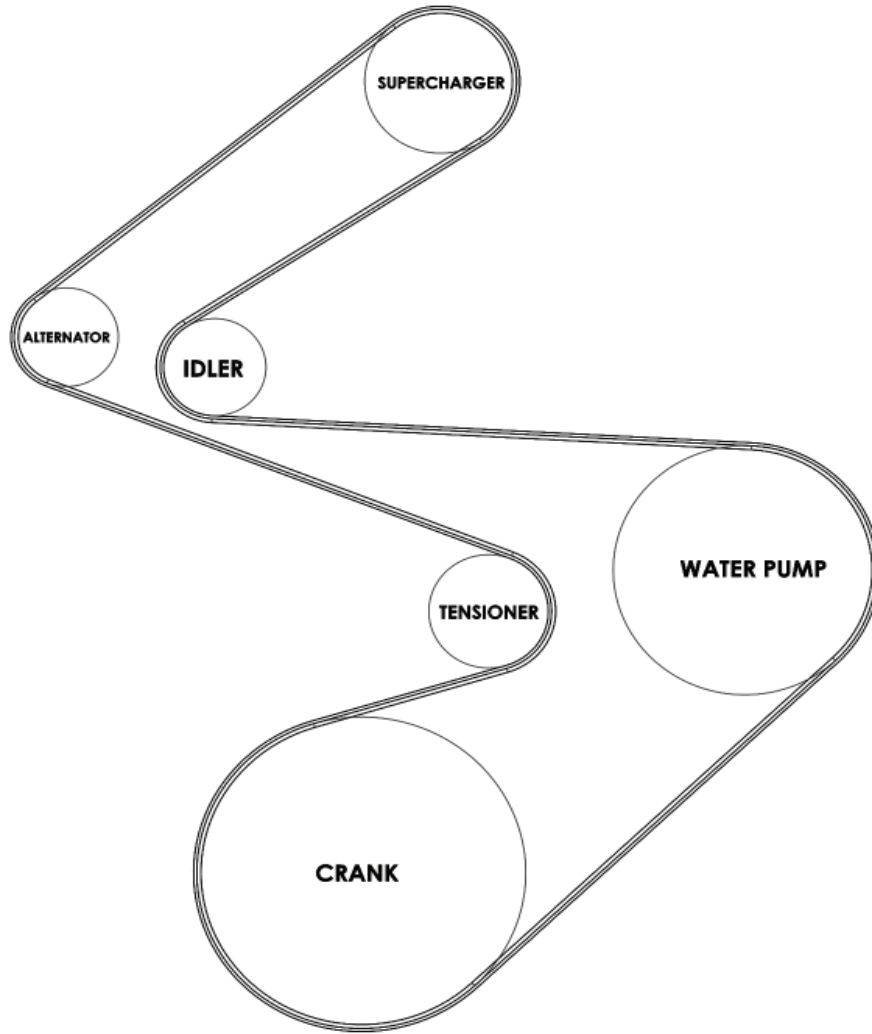

Belt Routing Diagram



NOTE: This vehicle IS NOT compatible with E85 fuel. You can only use premium gasoline fuel 91 Octane or better, Ethanol is NOT compatible with the engine after supercharger install.

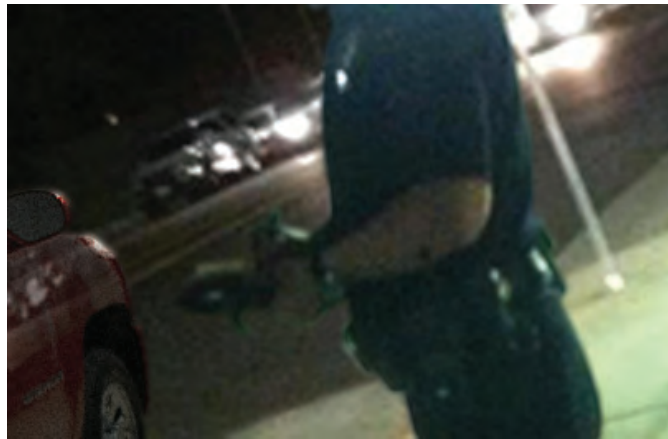

Please enjoy your "Magna Charged" performance responsibly!

MAGNUSON
SUPERCHARGERS