

# MAGNUSON

## SUPERCHARGERS

### Installation Instructions for: **Radix Max** Intercooled Supercharger System 08-09 Hummer H2



Step-by-step instructions for installing the best in supercharger systems.

**\* PREMIUM GASOLINE FUEL REQUIRED \***



**ATTENTION!**  
Your **MAGNUSON SUPERCHARGER** kit  
is sensitive to corrosion!  
Use only the vehicle manufacturer  
recommended coolant for your engine in  
the intercooler system as well.

Magnuson Superchargers  
1990 Knoll Drive, Bldg A, Ventura, CA. 93003  
(805) 642-8833  
[magnusonsuperchargers.com](http://magnusonsuperchargers.com)

# INSTALLATION MANUAL

## Magnuson Supercharger Kit Hummer H2, 6.0L Engine

Please take a few moments to review this manual thoroughly before you begin work: Make a quick parts check to make certain your kit is complete (see shipper parts list in this package). If you discover shipping damage or shortage, please call your dealer immediately. Take a look at exactly what you are going to need in terms of tools, time, and experience. Review our limited warranty with care. When unpacking the supercharger kit DO NOT lift the supercharger assembly by the black plastic bypass actuator. This is pre-set from the factory and can be altered if used as a lifting point!

Caution: Relieve the fuel system pressure before servicing fuel system components in order to reduce the risk of fire and personal injury. After relieving the system pressure, a small amount of fuel may be released when servicing the fuel lines or connections. In order to reduce the risk of personal injury, cover the regulator and fuel line fittings with a shop towel before disconnecting. This will catch any fuel that may leak out. Place the towel in an approved container when the job is complete.

**This supercharger system requires the use of only premium gasoline fuel, 91 octane or better. It is NOT compatible with E85, Ethanol, or Flex fuels.**

Magnuson Superchargers recommend that you run a minimum of one (1) tank of premium fuel through your vehicle prior to installation of the system to prevent any possible damage that may occur due to running the supercharged engine on lower octane fuel. **DO NOT add octane booster to existing fuel in your vehicle.**

Magnuson Superchargers systems are designed for engines and vehicles in “GOOD” mechanical condition. Magnuson Superchargers recommend that a basic engine system “Health Check” be performed prior to the installation of this supercharger system. Be sure to check for any pending or actual OBDII codes and fix/repair any of the stock systems/components causing these codes. If there are codes prior to the installation they will be there after the installation.

Magnuson Superchargers also recommend the following services to be performed on your vehicle before starting and running the vehicle post supercharger system installation:

- Fuel Filter change
  - Engine oil and oil filter change using the vehicle manufacturer’s specified products
- NOTE: It is VERY IMPORTANT to use the factory specified oil viscosity. The original equipment manufacturer has selected this grade of oil to work with your other engine systems such as hydraulic chain tensioners and variable cam controls. Deviation from this specification may cause these systems to fail or not function properly. Please refer to your owner’s manual for the recommended oil viscosity for your engine and application.

- On newer vehicles not requiring new spark plugs it is important to verify the spark plug air gap.

On older vehicles Magnuson Superchargers recommend these additional services to be performed:

- New spark plugs with the air gap set at the factory specifications OR new specifications if required by the installation manual.
- Engine coolant system pressure test and flush and refill. **NOTE: YOU MUST USE THE GM SPECIFIED COOLANT MIXTURE!**

Non “Magnuson Approved” calibrations or “tuning” will Void ALL warranties and CARB certification.

Take a look at exactly what you are going to need in terms of tools, time, and experience. Review our limited warranty with care.

**NOTE: Photography in this instruction booklet is for illustration purposes only. Vehicle manufacturers make small changes and revisions each model year, and some details of the photos may differ slightly from your application.**

**Make sure to have 91 or higher octane gasoline fuel in the tank.**

When unpacking the supercharger kit **DO NOT** lift the supercharger assembly by the black plastic bypass actuator. This is *pre-set* from the factory and can be altered if used as a lifting point!

### **Tools Required**

- Safety glasses
- Metric wrench set
- 1/4" drill bit
- 1/4", 3/8", and 1/2" drive metric socket set (standard and deep)
- 8mm hex (Allen) wrench
- 3/8" and 1/2" drive foot pound and inch pound torque wrenches
- Belt tensioner wrench or 1/2" breaker bar
- 7/32" socket
- Drill and 5/16" drill bit
- Phillips and flat head screwdrivers
- Fuel quick disconnect tools (included in kit)
- E5 inverted Torx socket
- Small or angled 3/8" drill motor
- Drain pan
- Compressed air
- Drive belt is a Gates #K061098.

After you finish your installation and road test your vehicle, please fill out and mail the limited warranty card, so we can add you to our files (this is important for your protection).

Please remember to follow all safety rules that apply when working, including:

- Wear eye protection at all times.
- Do not work on a hot engine.
- Be careful around fuel - use shop towels to catch any spills and dispose of towels properly.

### **Contact Information:**

Magnuson Superchargers  
1990 Knoll Drive, Bldg A  
Ventura, CA 93003

Sales/Technical Support Line: (805) 642-8833  
Website: [www.magnusonsuperchargers.com](http://www.magnusonsuperchargers.com)  
Email: [sales@magnusonsuperchargers.com](mailto:sales@magnusonsuperchargers.com)

# **MAGNUSON**

## *SUPERCHARGERS*

### **WARNING!**

**Before downloading the new software into your vehicles Programming Computer Module (PCM), make sure to turn off all power consuming accessories: heater, A/C, radio, dome light, etc. Turn off the daytime running lights by applying the emergency brake or by turning the headlamp switch counter-clockwise.**

### **Vehicle Programming Instructions for the Micro Tuner IMPORTANT!**

To ensure trouble-free programming of your vehicle's computer:

- \* Make sure the vehicle's battery is sufficiently charged.
- \* Turn off all accessories & close doors to prevent unnecessary drain on the battery.
- \* Do not attempt to program your vehicle without a battery charger connected.
- \* Improper battery voltage will result in failure of the programming process.
- \* Do not disconnect the cable or turn off the ignition during programming.
- \* Apply emergency brake to disable daytime running lights.
- \* Verify you have good battery connections.

1. **If your kit has a provided handheld tuner follow the instructions in the provided pamphlet to install your tune. Your handheld tuner may not match the one shown.**



2. Your Intercooler system is sensitive to corrosion. It's very important to use the OEM recommended coolant mixture in your supercharger system as well.



3. Your system requires the use of minimum 91 Octane gasoline fuel. This system is not compatible with E85 fuel. Ensure that the fuel in the tank is 91 octane or higher.

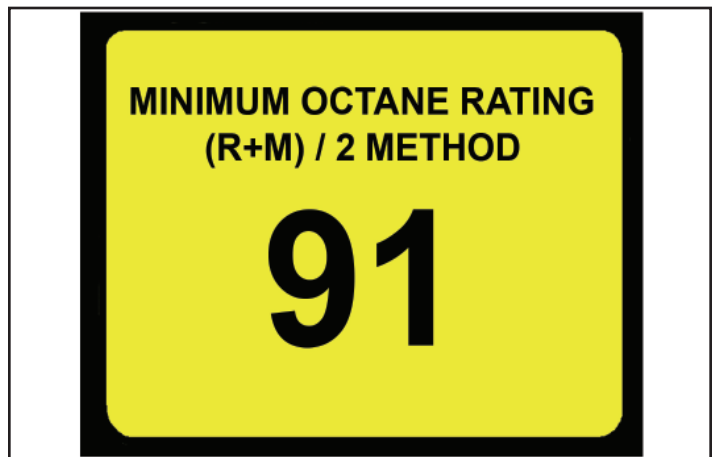

4. Exercise extreme caution and common sense when working around gasoline. Extinguish all open flame or other sources of ignition and be sure to perform the following steps in an area with adequate ventilation. Personal protection in the form of eye protection and fuel resistant gloves are strongly recommended.



5. Relieve the pressure in the fuel tank by removing the fuel filler cap.



6. With a 10mm wrench disconnect the (-) negative battery cable. Make sure the cable is far enough away from the battery that it does not accidentally touch the battery and make connection during the installation. (Wrap negative cable connector with electrical tape.)



7. Remove the plastic sight shield by lifting from the front and pulling free from the engine, this will not be reused.



8. Using a flat blade screwdriver or an 8mm nut driver, loosen the two large hose clamps holding the air cleaner duct assembly.



9. Pull the PCV valve cover hose on the passenger side of the vehicle free from the air-duct assembly.



10. Remove the duct assembly by lifting it out.



11. Rotate the rigid PCV hose just disconnected toward the driver side of the vehicle (appx. 90°) to expose the retaining clip release tab. Press the tab clockwise (as seen from the front of the vehicle) to release. Pull the hose from the passenger side valve cover barb, this hose will not be reused.



12. Disconnect the electrical connector on the throttle body.

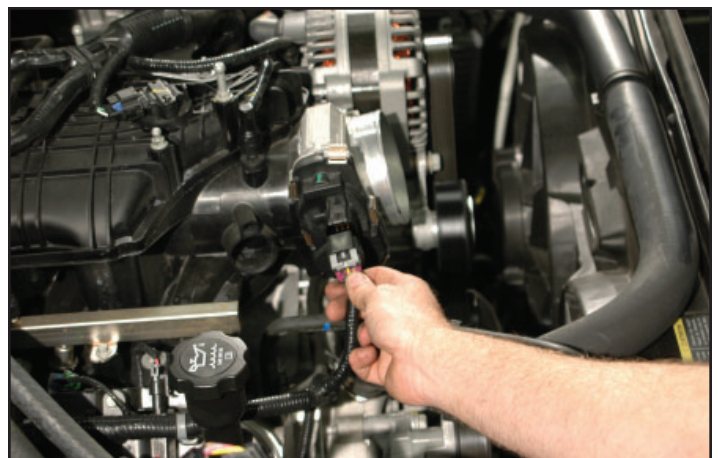

13. Using a 10mm socket wrench remove the three bolts and one nut holding the plastic wire harness retainer to the intake manifold.



14. Disconnect the eight Fuel injectors, and alternator voltage sensor.

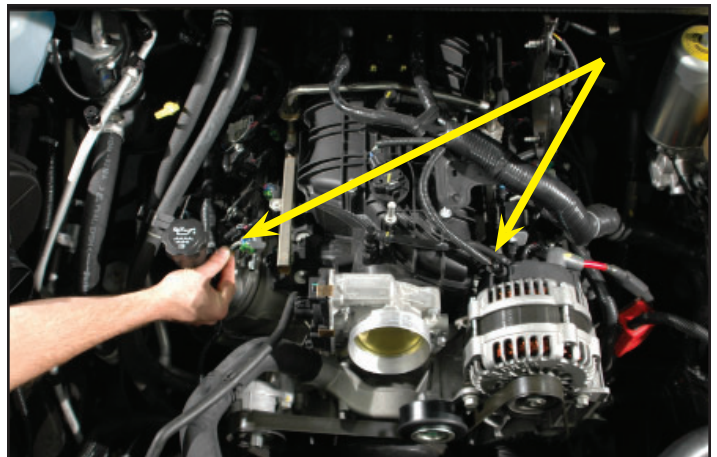

15. Disconnect the Manifold Absolute Pressure (MAP) sensor. The MAP sensor has a blue tab that locks the release button. Use a small screwdriver to first pry the blue tab out a bit, then the release button will work.

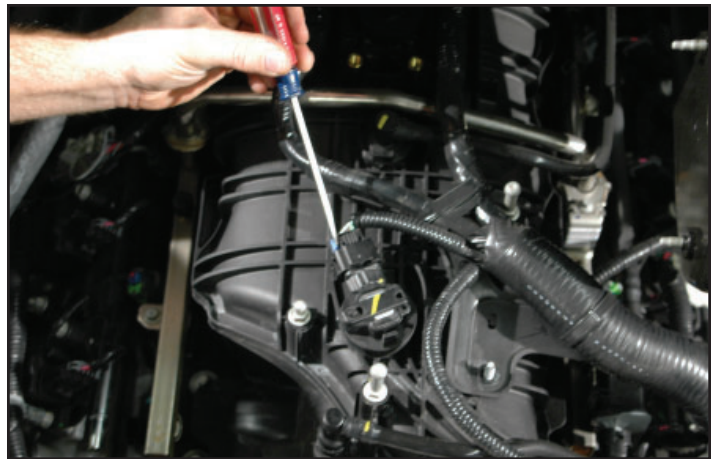

16. Lift the electrical harness from the top of the engine and pull carefully off to the side.





17. Unplug the EVAP solenoid electrical connection.

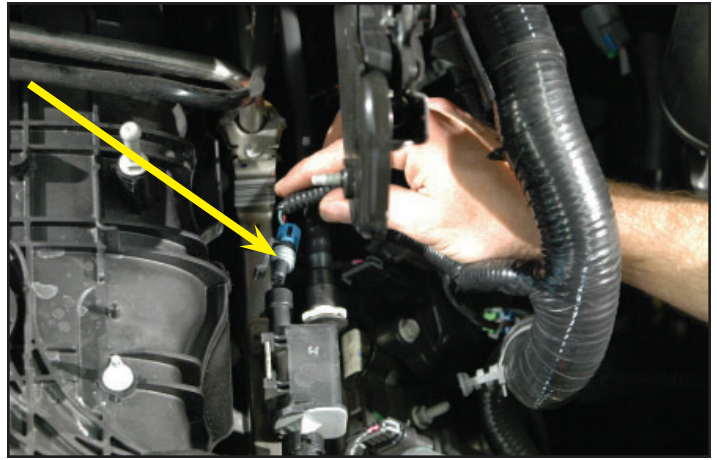

18. Disconnect the EVAP vent tube from the solenoid by squeezing the retainer, and then release the tube from the solenoid. Follow the same procedure on the other end of the EVAP vent tube and remove the tube from the vehicle. We will however need the fittings.

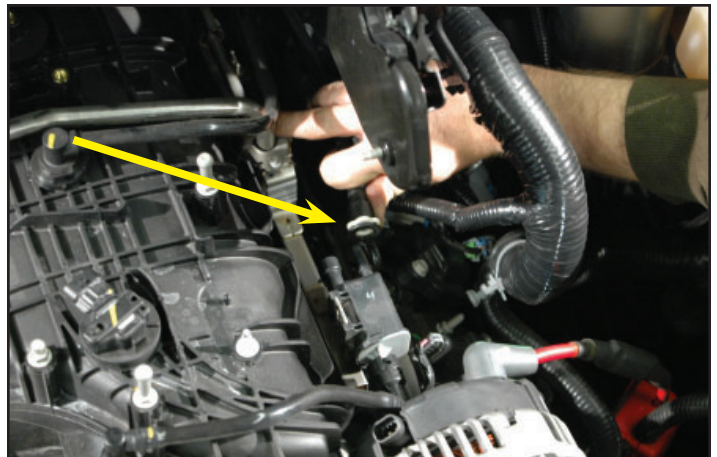

19. Remove the positive crankcase vacuum hose PCV from the intake manifold. To remove this hose, first pull the PCV connection free from the rear of the driver side valve cover. Rotate the rigid hose 90° clockwise, as viewed from above, this will align the release slots for the intake manifold connection.



20. Release the fuel line safety clip, and with the fuel line disconnect tool (included in kit), remove the fuel lines from the fuel rail. Be careful, the system may still be under pressure. Use shop rag under the connections to catch any fuel spills. Dispose of shop rags appropriately. Stay away from sparks and flames **(Remember fuel is highly flammable)**.

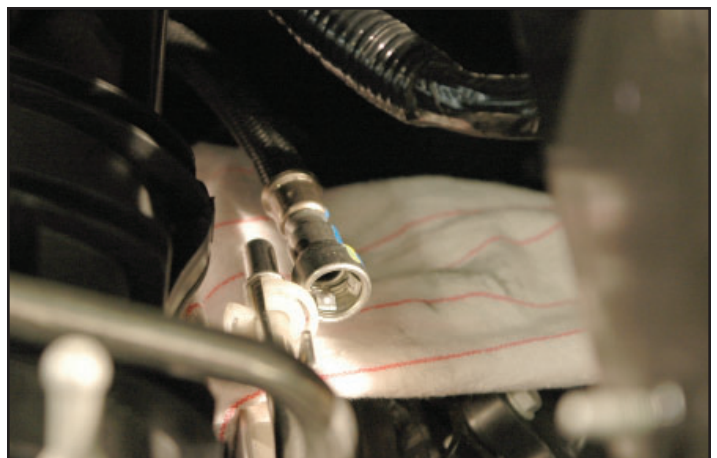

21. Use a 15mm tensioner wrench or large socket wrench/breaker bar, compress the tensioner pulley and remove the stock serpentine belt from the vehicle. This belt will not be reused.



22. Using a 15mm socket wrench or standard wrench remove the two bolts holding the factory belt tensioner to the bracket and remove the tensioner. (Put tensioner and bolts aside for later use.)

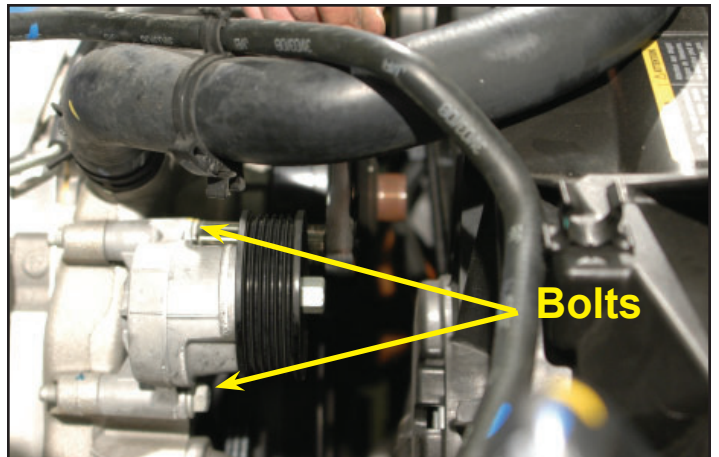

23. Be sure the battery has been disconnected (step 6). Using a box wrench disconnect the battery positive terminal from the back of the alternator.

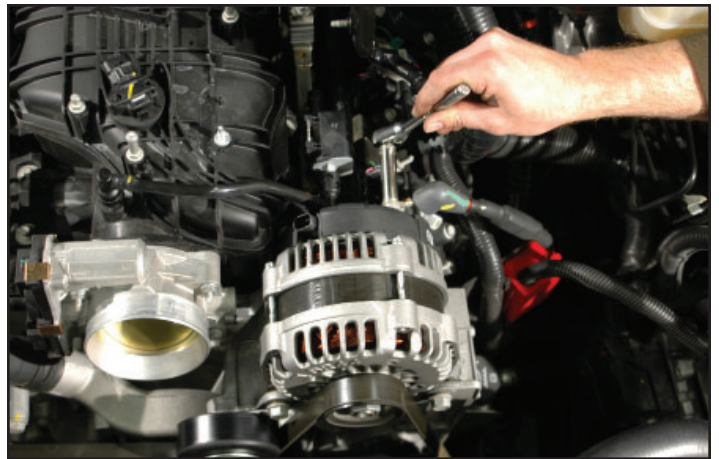

24. With a 15mm socket wrench remove the two bolts holding the alternator to the alternator bracket. Remove the alternator.



25. Use an 8mm socket wrench to remove the ten intake manifold bolts.

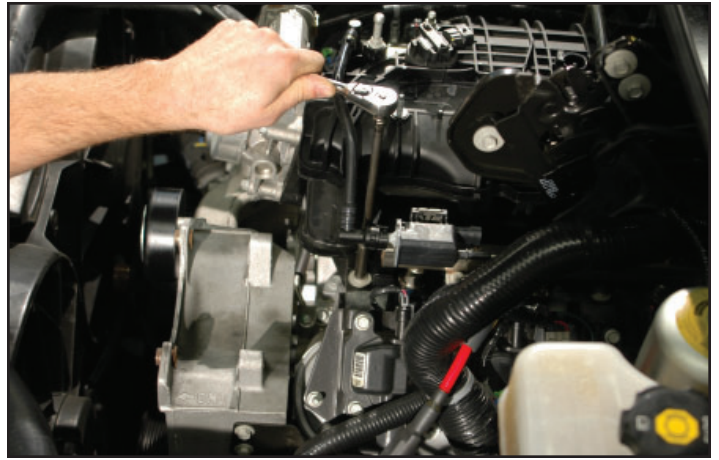

26. Carefully remove the intake manifold assembly and set aside.



27. Using a vacuum cleaner, remove any dirt or debris from the intake port area. Be careful not to get any dirt in the intake ports.



28. Wipe heads clean using lacquer thinner, alcohol, or suitable solvent.



29. Cover the intake ports with tape or clean rags to keep dirt and objects from entering the engine. (Remember be clean.)



30. Remove idler pulley using a 15mm socket wrench.

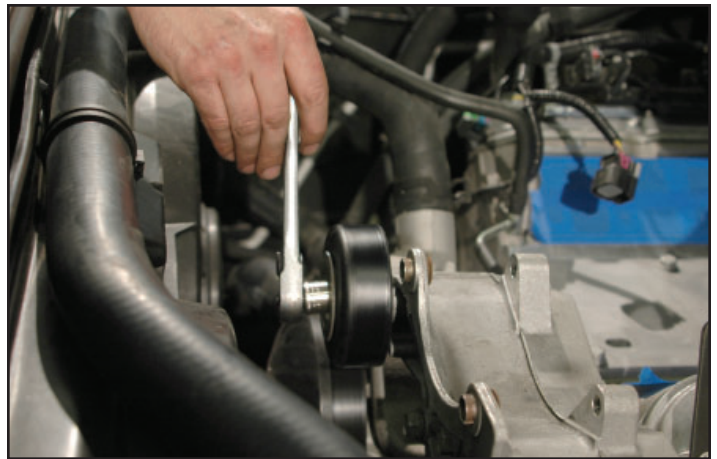

31. Use a soft hammer to disassemble the idler pulley. The parts on the right side will not be re-used; the parts on the left are required in a later step.

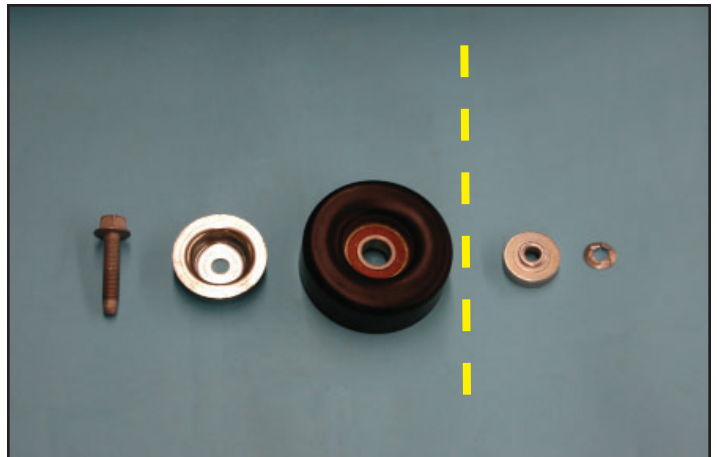

32. After removing tensioner, use one removed bolt from A in the hole shown in photo B.

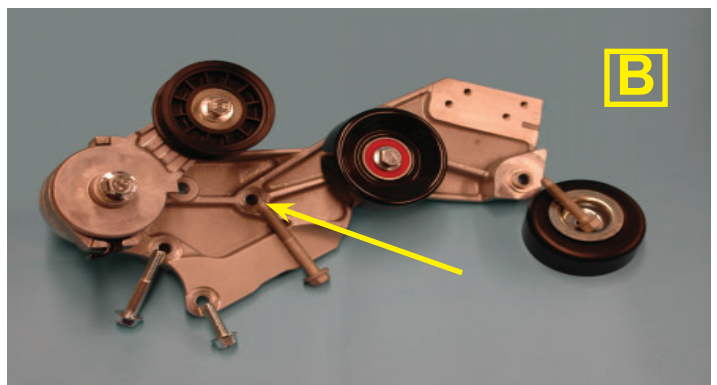
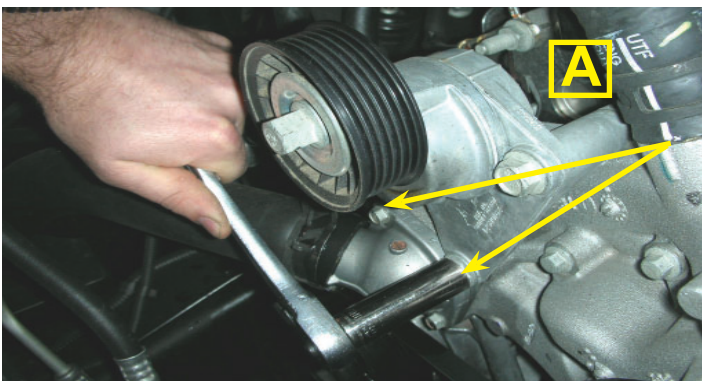

33. Install new tensioner with new bracket support assembly, where old tensioner was removed.



34. Replace the Idler pulley removed in step 30 onto the new bracket support assembly. See step 31 for parts required.

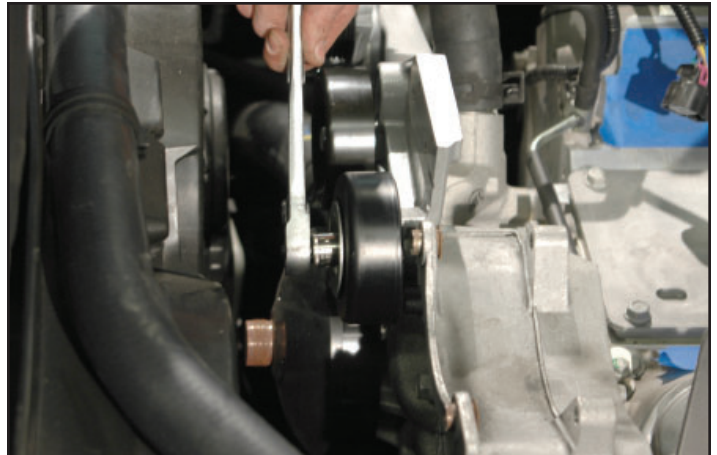

35. Torque all fasteners to 40 ft-lbs.

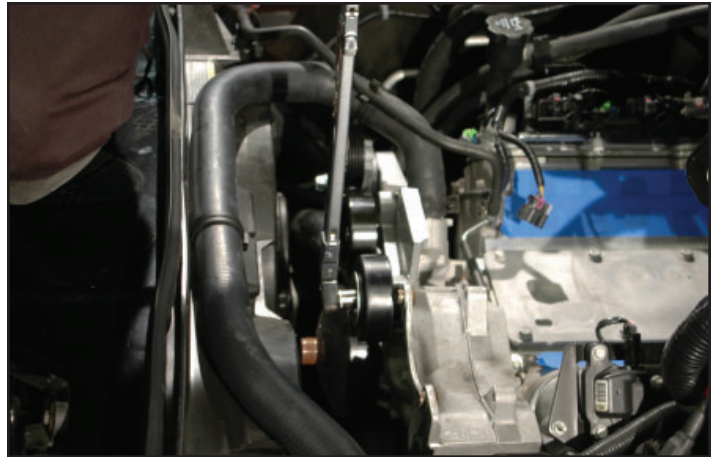

36. Carefully cut out & remove cable guide/mount that was mounted on top of intake.



37. Remove the OEM intake manifold gaskets from the base of the stock intake manifold.

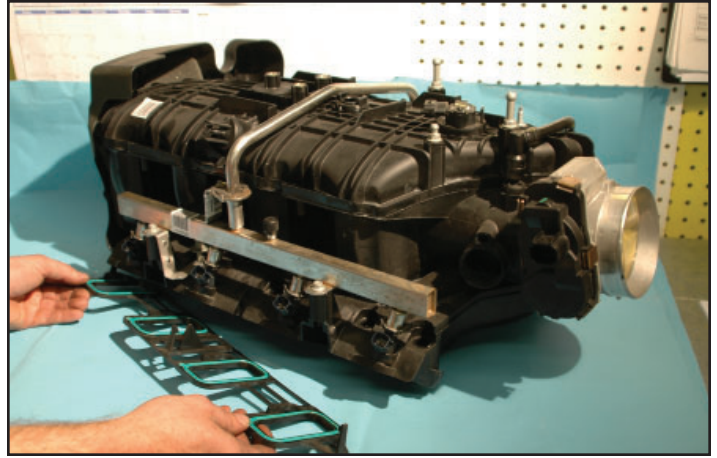

38. Install the intake manifold gaskets just removed onto the new supercharger manifold. Ensure that the gaskets are fully seated into the reliefs in the manifold.

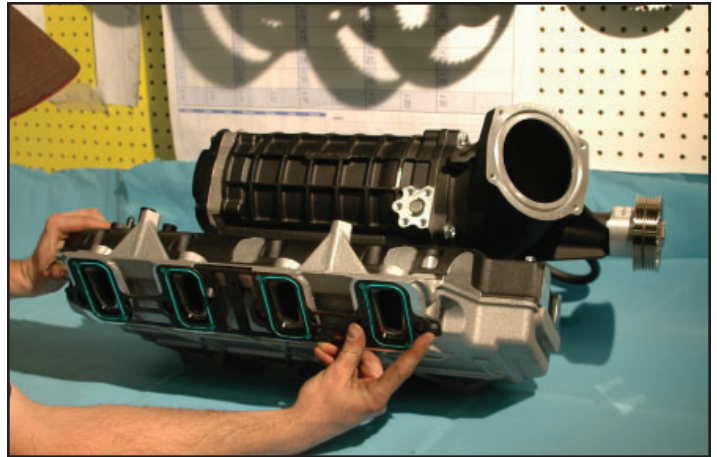

39. Remove the stock MAP sensor by removing the retaining clip with a screwdriver and then gently pulling up on the sensor. Be careful not to damage the O-ring seal. **NOTE: On 2009 model year this connector may have changed. To remove, insert a small screwdriver into the slot opposite the slide-tab lock. Lever the locking tab outward to release the lock, then slide the lock to release the clip.**



40. The clip can now be removed, now carefully lift the sensor out. **(Make sure that the MAP sensor seal does not get damaged, as it will be reused.)**



41. For 2009+ MAP sensor skip to step #42. If you have the 99-08 style MAP sensor you will need to install the provided bushing. **YOU MUST install the bushing with sealant to prevent a vacuum leak.** We recommend black silicone RTV or green Loctite 680. Be sure to wipe off any excess sealant inside the bushing. Allow sealant to cure before starting engine.

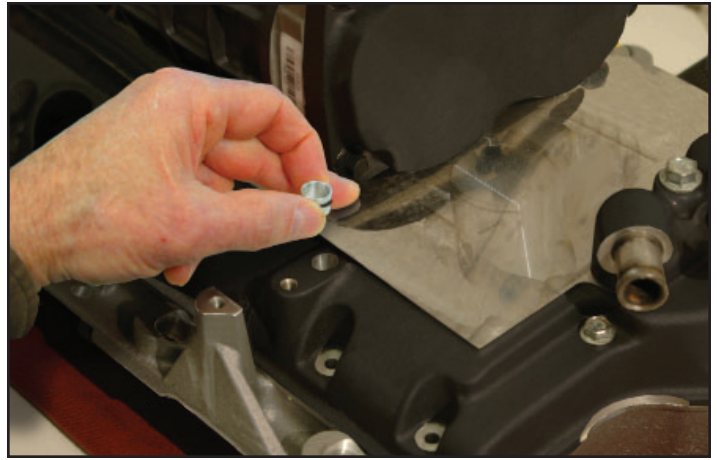

42. Apply a bead of the supplied Lubriplate lubricant to the MAP sensor seal and press the MAP sensor into the provided hole in the supercharger manifold as shown.

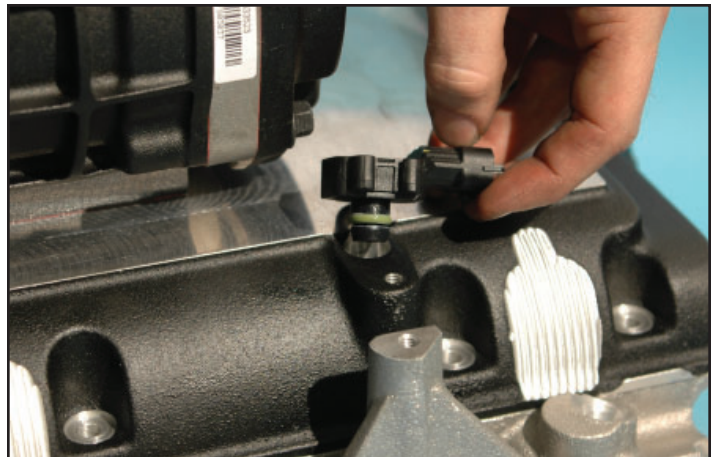

43. Using a 4mm Allen wrench, install the MAP sensor retaining clip with the provided 6mm button head screw as shown.

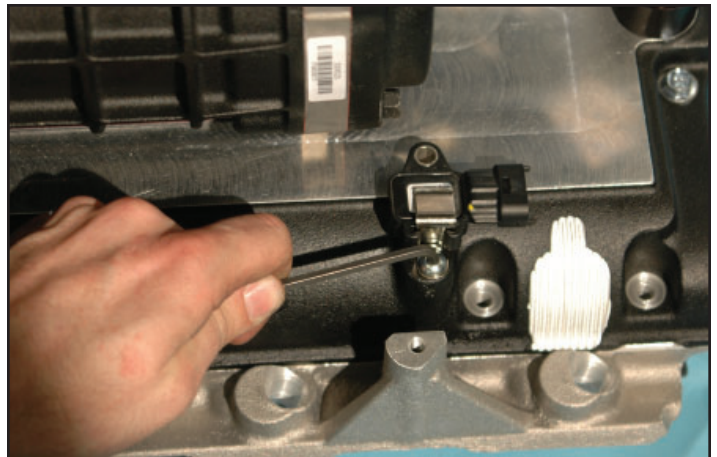

44. Spring the lock clips and remove the rigid EVAP hose from the stock intake manifold.

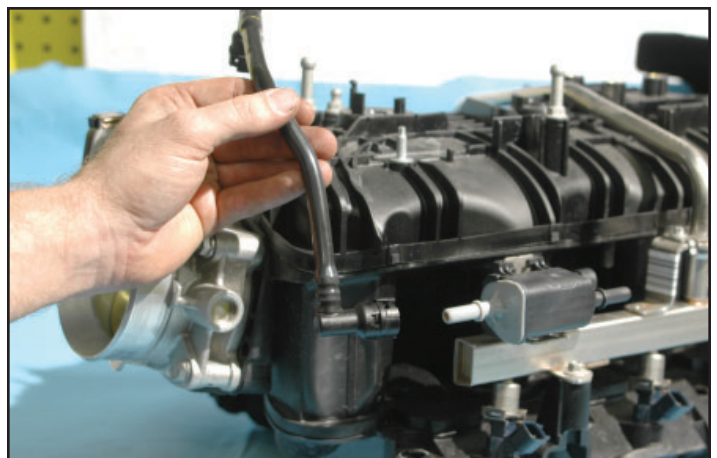

45. Remove the EVAP sensor from the fuel rail by depressing the release tab and lift the sensor free.

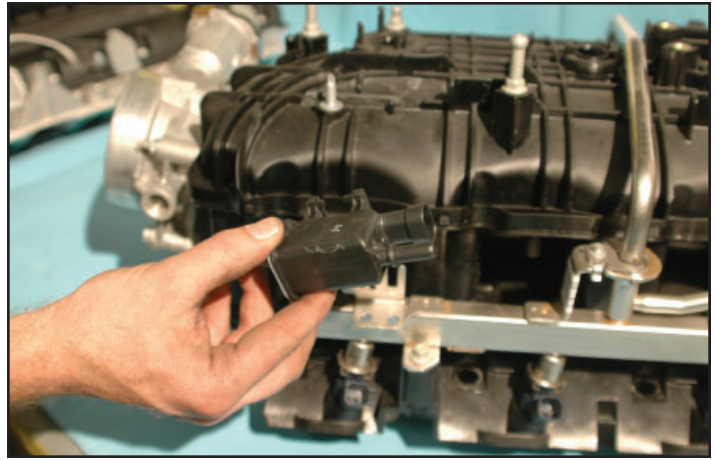

46. Use a 10mm socket wrench to remove the stock throttle body from the stock intake manifold.

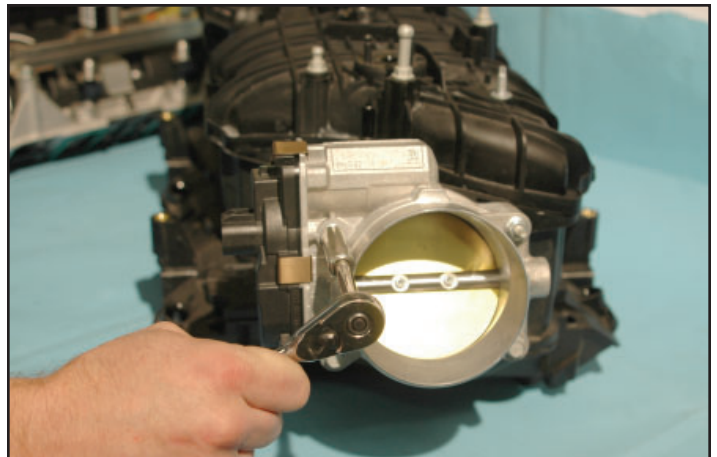

47. Use an E5 inverted Torx socket to remove the two factory studs from the stock intake manifold.



48. Remove the throttle body O-ring from the OEM intake manifold.





49. Install the O-ring just removed onto the new Supercharger housing as shown.

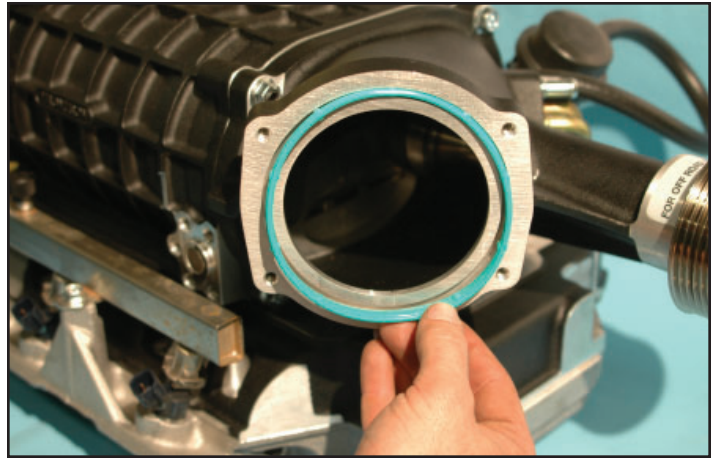

50. Install the two throttle body mounting studs removed in step 47 onto the Supercharger housing as shown using an E5 inverted Torx socket.

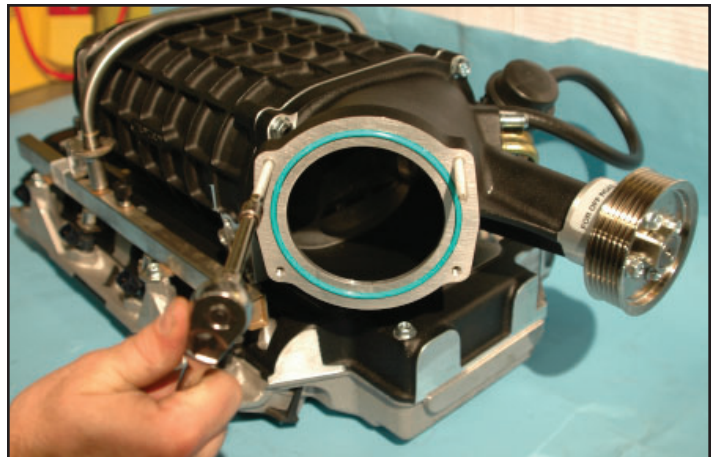

51. Install the stock throttle body removed in step 46 onto the new Supercharger housing using a 10mm socket wrench. Torque the throttle body nuts and bolts to 106 in-lbs. Verify your torque wrench settings.



52. Spray a thin coat of silicone or similar product to assist seating of the manifold seals.



53. Using an assistant, carefully lower your new Supercharger manifold assembly into place.



54. Start all ten fasteners by hand to ensure proper lineup. Torque all ten fasteners in a criss-cross pattern to 106 in-lbs.

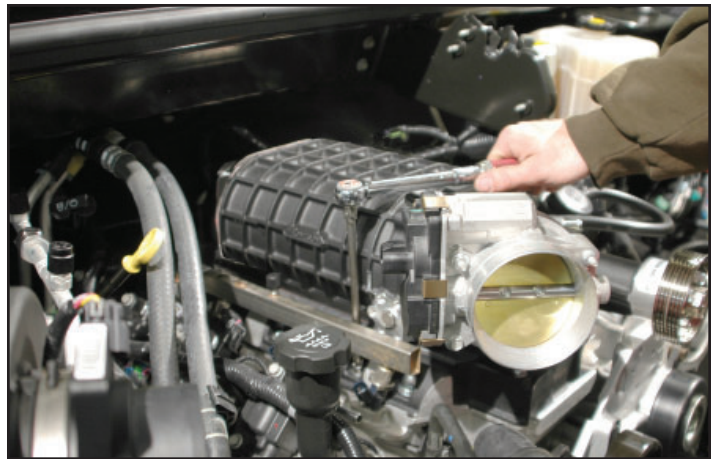

55. Assemble the EVAP solenoid bracket and bolts onto the fuel manifold.

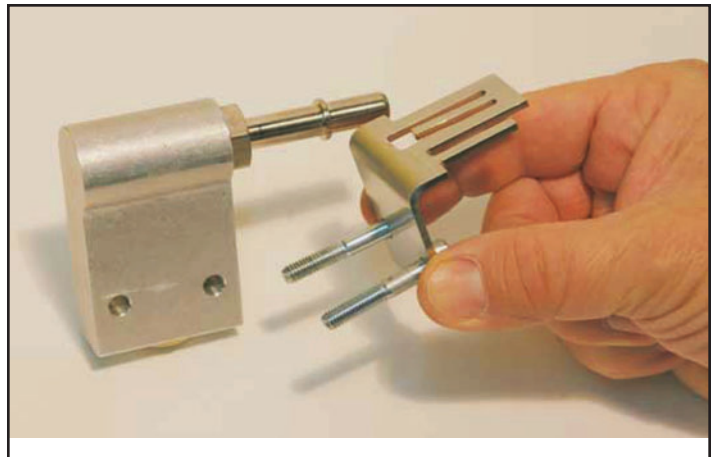

56. Using some of the lubricant supplied, install the O-ring into the recess on the fuel rail. Install the fuel manifold and bracket onto the fuel rail. Take care not to pinch the O-ring.

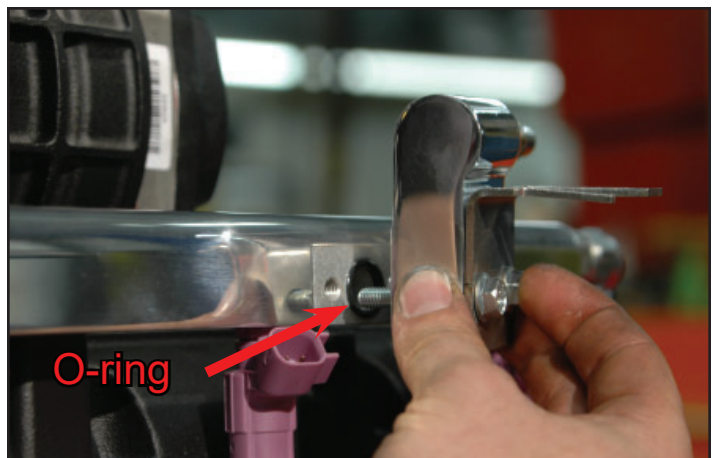

57. Torque the fuel manifold bolts to 106 in-lbs using a 10mm socket and torque wrench. Verify your torque wrench settings.

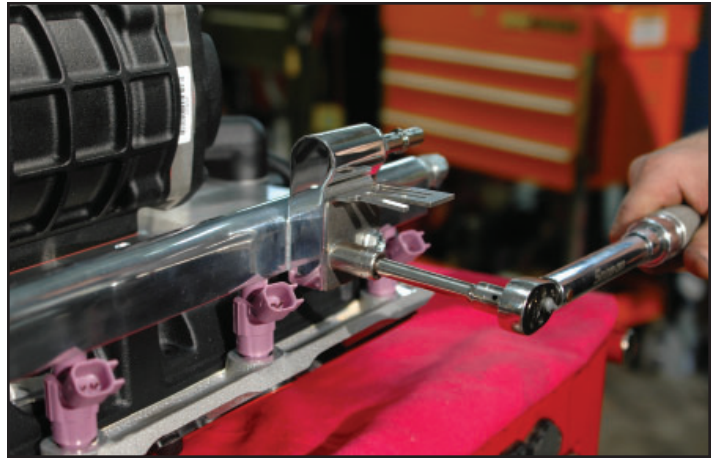

58. Push the fuel line connector on to the fuel manifold. Ensure that the fuel line is pushed all the way on. Pull on the connector to check that it is secure, you should not be able to remove the connector unless you use the removal tool.



59. Replace the stainless steel safety clip that was removed in step 20. **Bend the single, short tab on the EVAP bracket slightly. This will create a tight fit with the EVAP solenoid.**

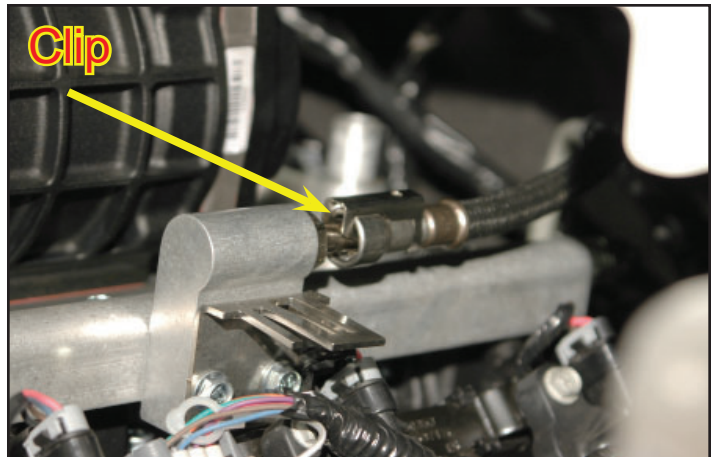

60. Re-attach injector plugs and other related sensors.



61. You will need a bit more wire for the alternator voltage sensor plug. Pull the main wiring harness split loom off the mounting stud at the front driver side valve cover. Remove about 4" of the main wiring split loom tape (1-1/2" in diameter) and pull the alternator plug wires out of the split loom about 4".

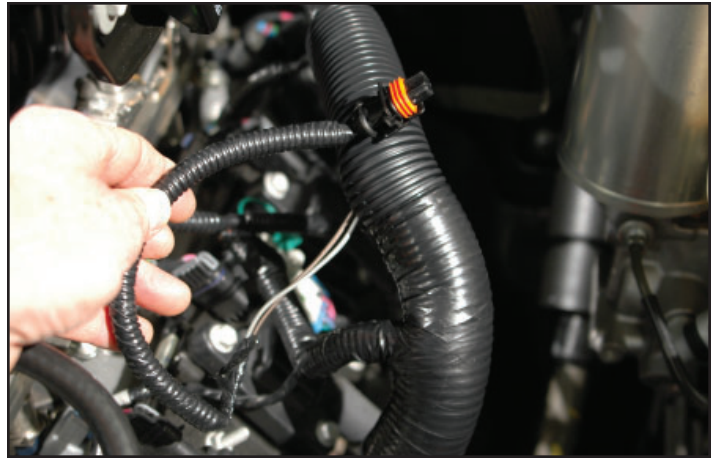

62. Cover the Alternator plug wires with the provided 1/4" split loom and re-tape the new and existing split loom.



63. Route the MAP sensor wires between the fuel line and fuel rail, then plug into the Map sensor at the driver side rear of the Supercharger manifold lid.



64. Attach the EVAP sensor back on the fuel rail.

**NOTE: The electrical connection should point back, toward the firewall.**

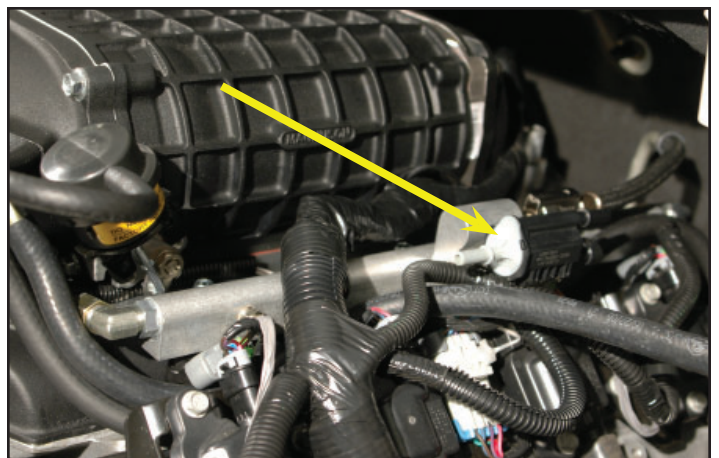

65. Plug the EVAP sensor wires back on the EVAP sensor. **NOTE: The plug should be toward the firewall.**



66. Carefully cut the fittings off of the EVAP hose removed in step #18. Be careful to not damage the fittings.

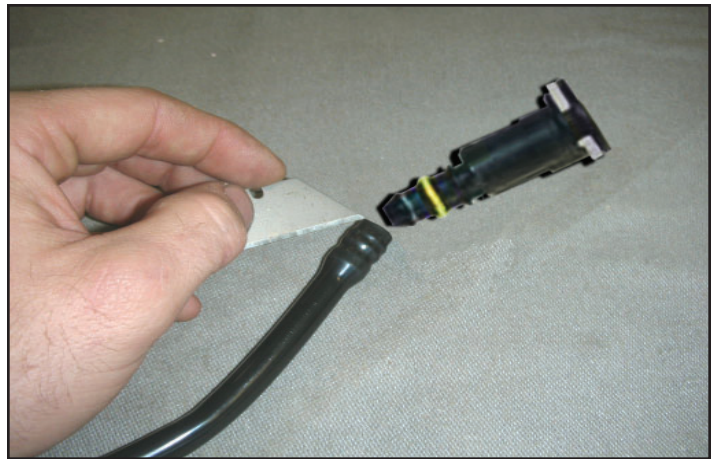

67. Cut a section of the supplied 3/8" hose to 11" in length. Install the factory fittings removed in the previous step onto the ends.



68. Connect the straight fitting of the EVAP sensor hose just created onto the barb at the rear driver side of the engine from whence it was removed. Then plug the end with the test port onto the rear barb of the EVAP sensor.



69. Locate the two IAT white wires on the driver side of the engine between the fuel rail and the Supercharger. Using the supplied white wires and shrink connectors provided, strip  $\frac{1}{4}$ " off all ends, and crimp these wires together extending their reach.

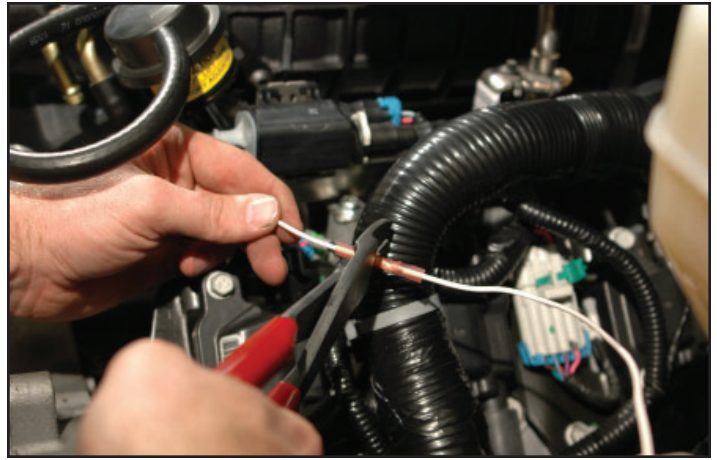

70. Use a heat gun or hair dryer set on high, shrink the insulation on the connectors so that it contracts around the wires completely. **You MUST shrink the insulation, as crimping the connectors alone is NOT enough to secure them.**

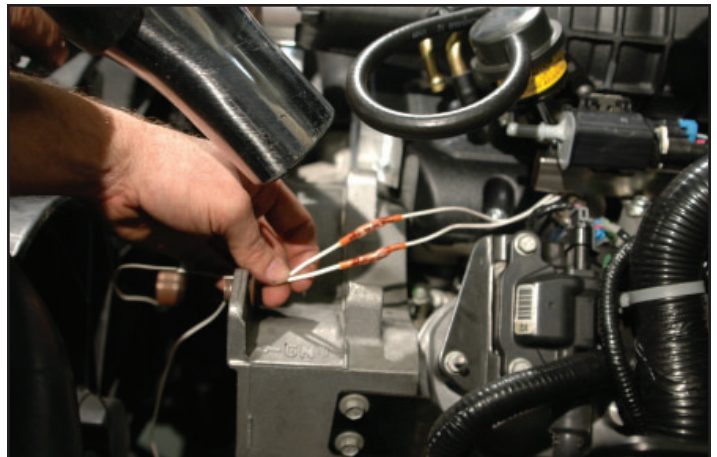

71. Cut a piece of the  $\frac{1}{4}$ " split loom provided to cover these wires plus about 12". Tuck the wires inside leaving the ends exposed through the side of the split loom and route the split loom under the Supercharger nose toward the passenger side of the vehicle.

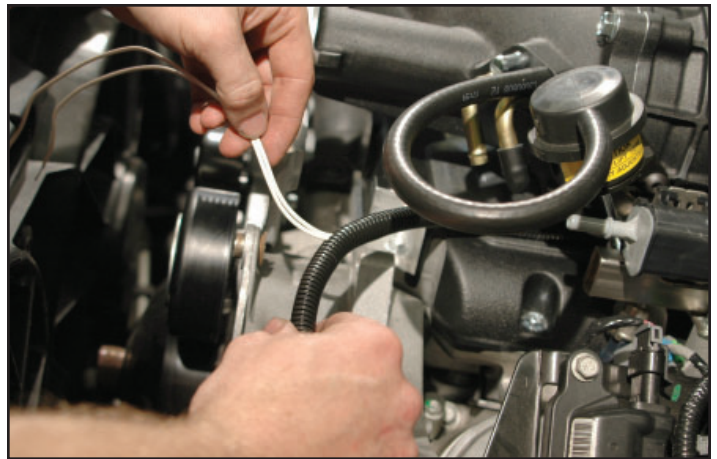

72. Locate Mass Air Flow (MAF) sensor on the air-box. Pull the split loom off a bit to expose the wires. Cut the two tan wires approximately 2" from the MAF connector.



73. Remove the tape to the junction at the wire harness, and pull the two tan wires from this flex loom back to the next junction in the wire harness.

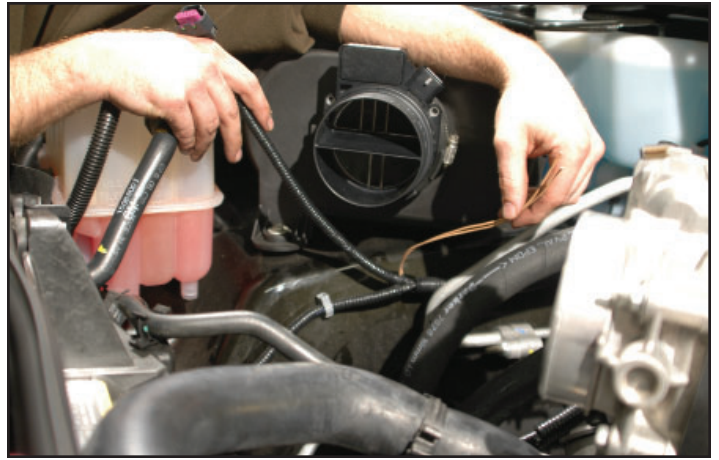

74. Using the new Intake Air Temp (IAT) wires you just extended and crimp/shrink connectors supplied, connect the extended wires to the tan wires you separated that run through the harness to the vehicles computer. The ends of the wires to the MAF plug will be abandoned. Strip about ¼" of insulation from the ends of the tan wires to the computer and the extended white wires. Crimp the connectors on.

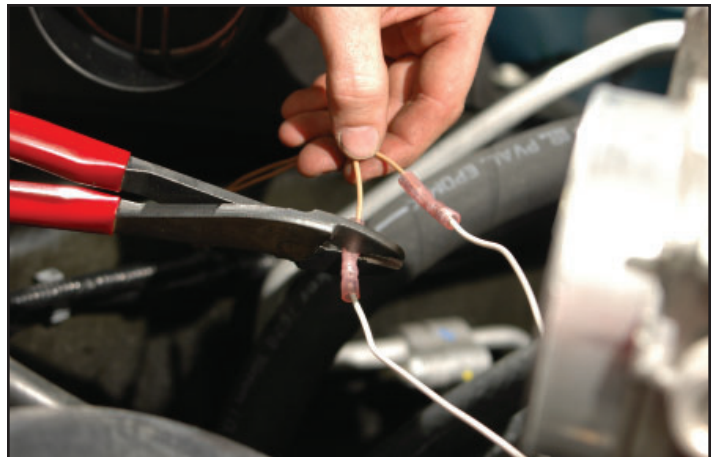

75. Using a heat gun or blow dryer set on HIGH; shrink the insulation on the connectors so that it contracts around the wires completely. You must shrink the insulation, as crimping the connectors alone is not enough to secure them! Cover the remaining IAT exposed wires with the split loom extension and tape over all junctions. Optionally you can completely cover with tape.

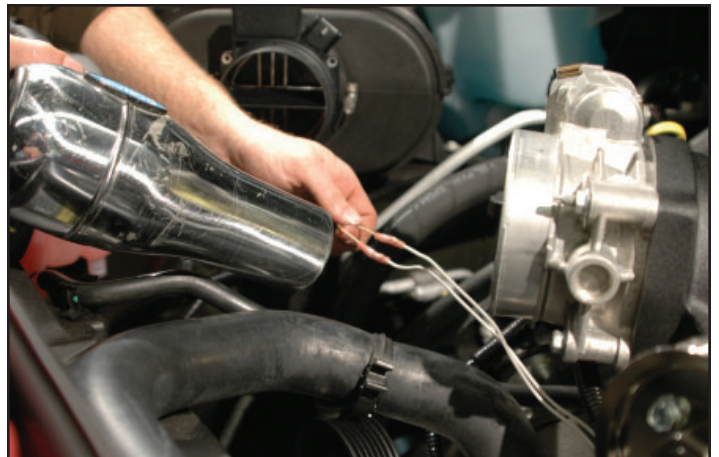

76. Plug in the throttle body connector.



77. Cut a section of the 3/8" hose to 25" in length. Plug one end of this hose onto the PCV barb at the rear, driver-side valve cover.



78. Route this hose forward between the coil brackets and injectors. Plug the remaining end into the front supercharger barb as shown.



79. Cut a piece of the provided 3/8" hose to 16-1/2" in length. Attach and clamp one end to the front barb on the EVAP Solenoid.

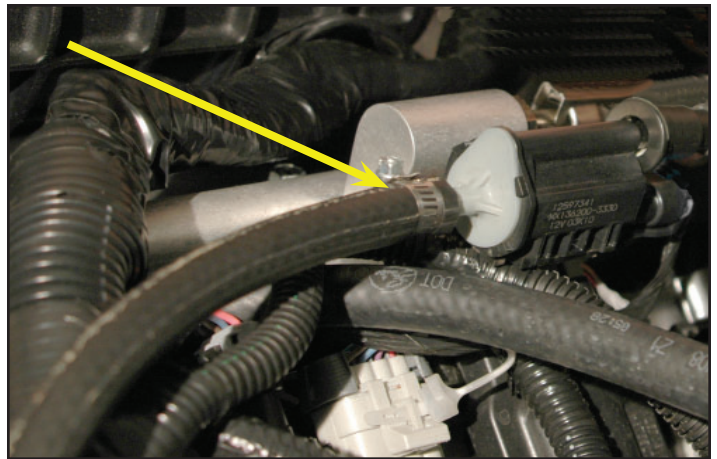

80. If not done in step 65, plug in the electrical connection to the EVAP Solenoid.





81. Attach supercharger nose drive support, torque bolts to 18 ft-lbs. Verify your torque wrench settings.

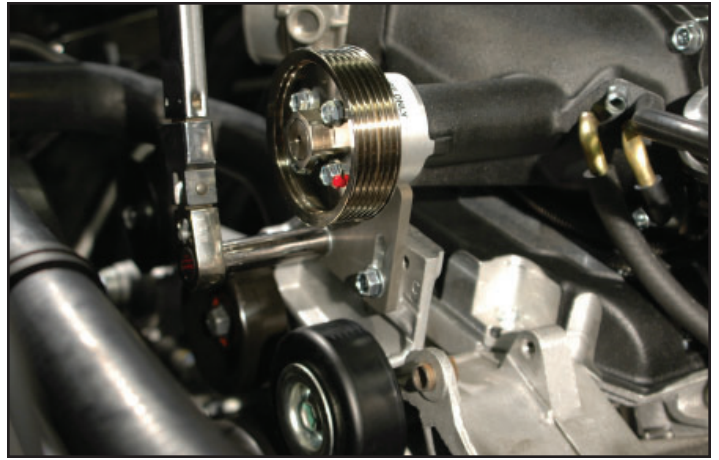

82. Remount alternator using OE hardware, torque bolts to 40 ft-lbs. Verify your torque wrench settings.

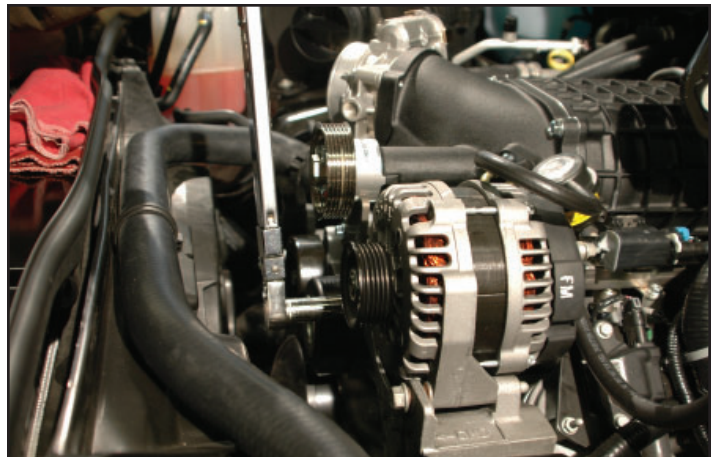

83. Connect the remaining end of the front EVAP Solenoid hose attached in step 79 onto the inlet barb of the supercharger as shown.

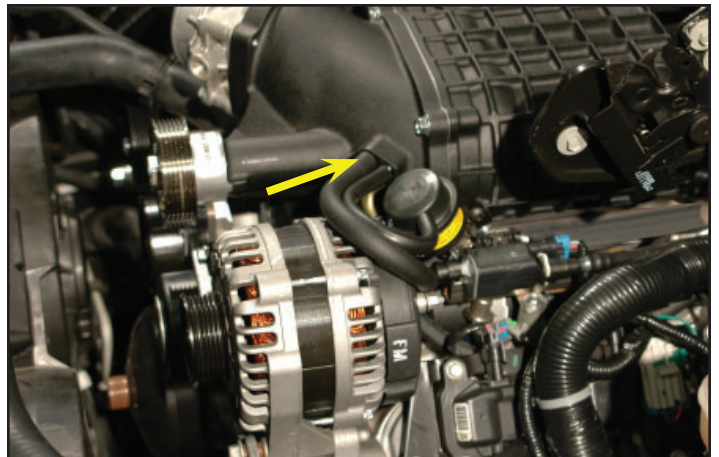

84. Re-attach the alternator battery (+) cable to the alternator post using a 10mm socket or box wrench, cover with post sock.

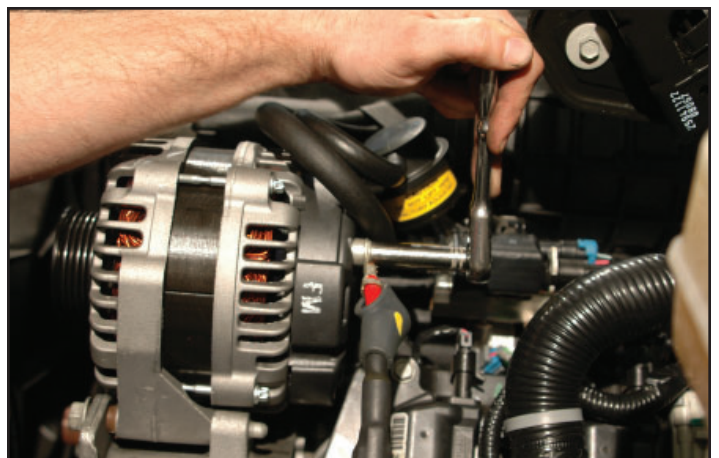

85. Plug in the alternator voltage sensor cable.

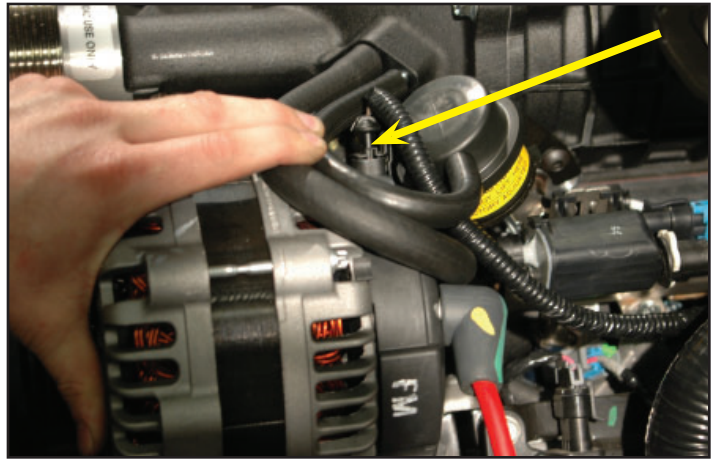

86. Compress the belt tensioner with a 15mm wrench/breaker bar and while compressed, insert the provided dowel pin in the tensioner bracket to hold the belt tensioner in the compressed position. Using the belt routing diagram provided, route the belt on all pulleys verifying that all pulleys are accounted for.

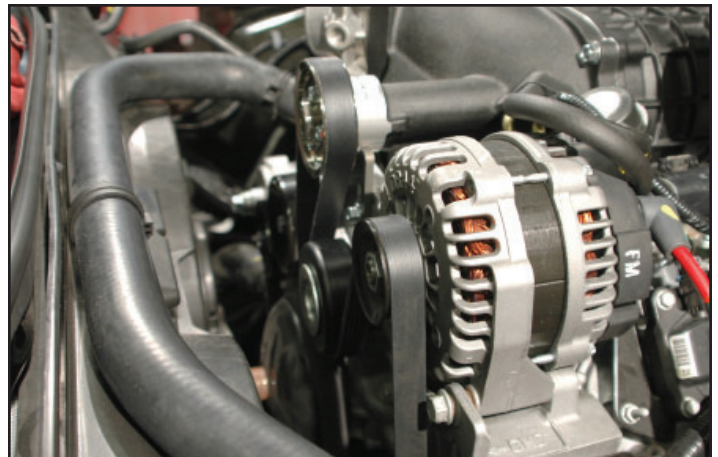

87. Press the supplied sliding idler pulley down to its tightest position and torque to 40 ft-lbs. Using the 15mm tensioner or breaker bar, release the tensioner and remove the retaining pin placing tension on the drive belt. Drive belt is a Gates #K061098.

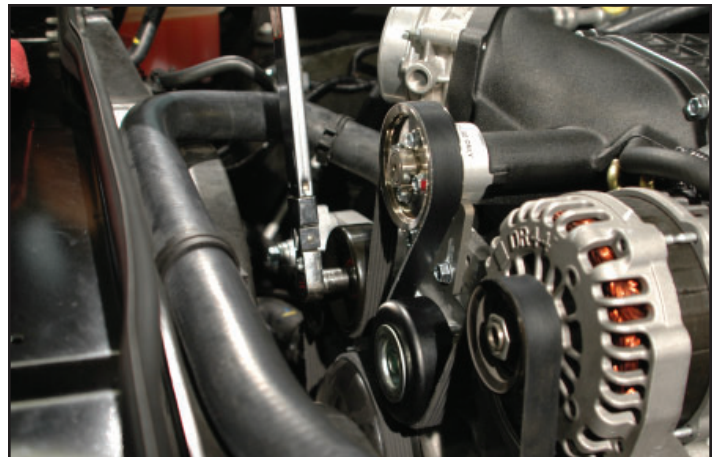

88. Affix the belt routing and vacuum diagram to the mid radiator front support as shown.

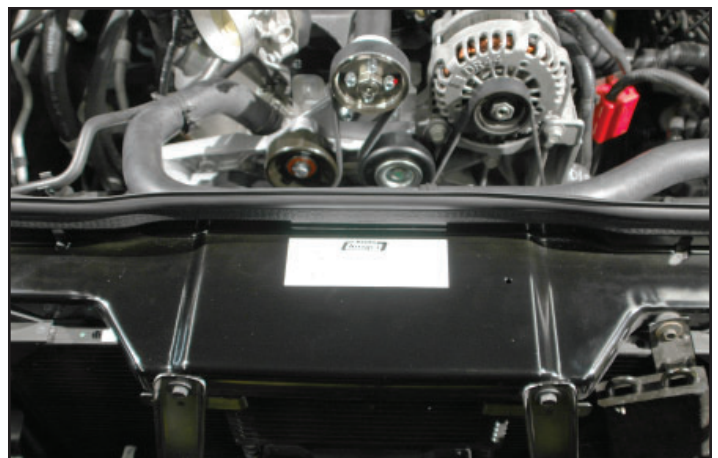

89. Attach the reservoir mounting bracket to the reservoir with the three supplied bolts. Mount the reservoir to the middle-passenger-side fuel rail mounting post using the provided bolt and 1/2" spacer below the mounting bracket, and torque back to 106 in-lbs. Verify your torque wrench settings!

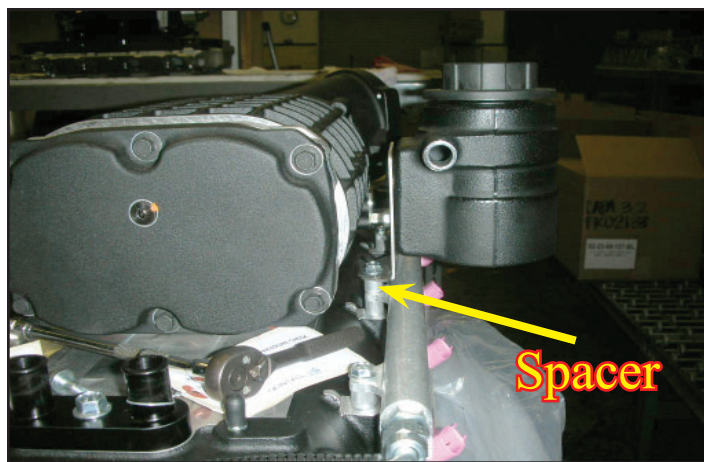

90. On the front end of the passenger-side wheel well in the engine compartment: Drill two 1/4" holes. Using the existing hole for the plastic wiring loom clamp as a guide (removed in this photo), go forward 1-1/4" then down 2". Drill your first hole here. Go down from that hole an additional 2-1/4" and drill your second hole.

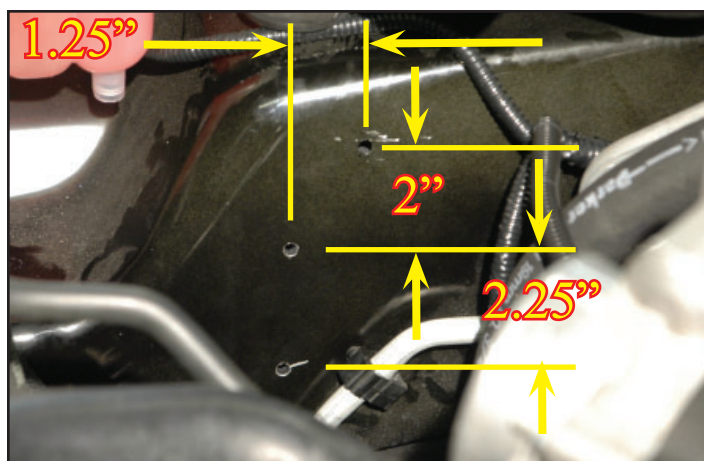

91. Pre-place the supplied #36 Adel clamps on the intercooler pump as shown. The supplied bolt threads will help hold the clamps in position.

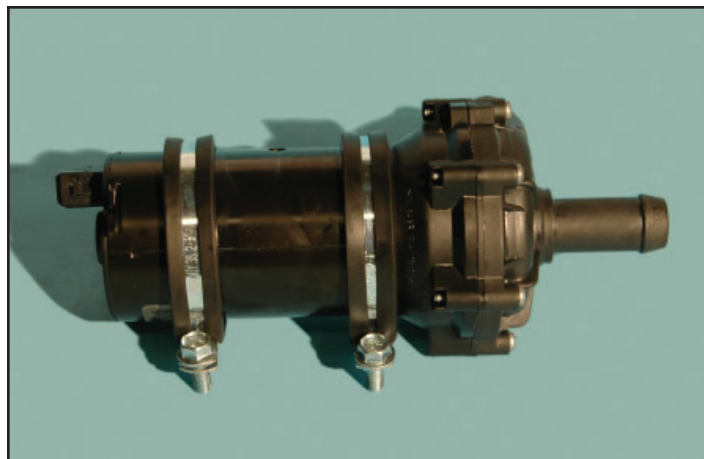

92. Push the bolts of the Adel clamps through the fender well and finger the nuts on. Make sure the pump discharge barb is just above the hose from the water pump to the radiator overflow reservoir. Tighten the bolts.



93. Replace the wire loom clamp and re-attach the wire loom.



94. Release the grille by removing the four 10mm bolts (two each side) to the outside of the turn signal lamps.

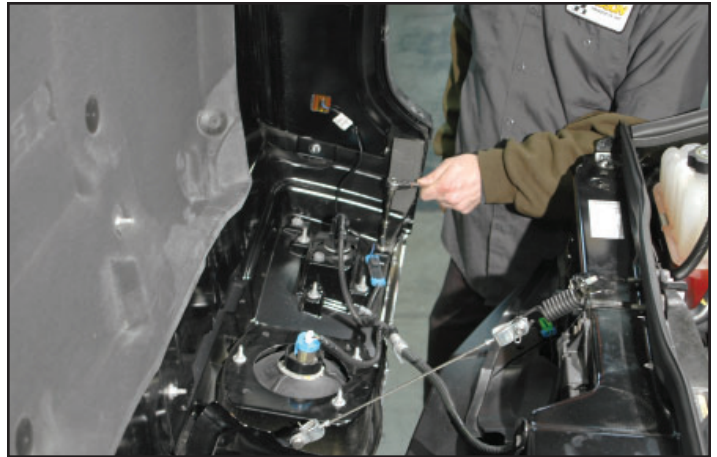

95. Lower the hood back down, remove any brush guards or push bars to expose the original equipment grille. Reach through the grille from the front and pull back to remove.



96. Cut out the supplied template. Make sure to cut out the center oval as well. Align this oval with the existing oval hole in the middle of the fascia support bracket. Tape the template in place and mark the holes using either a spring punch (shown) or a center punch and hammer.

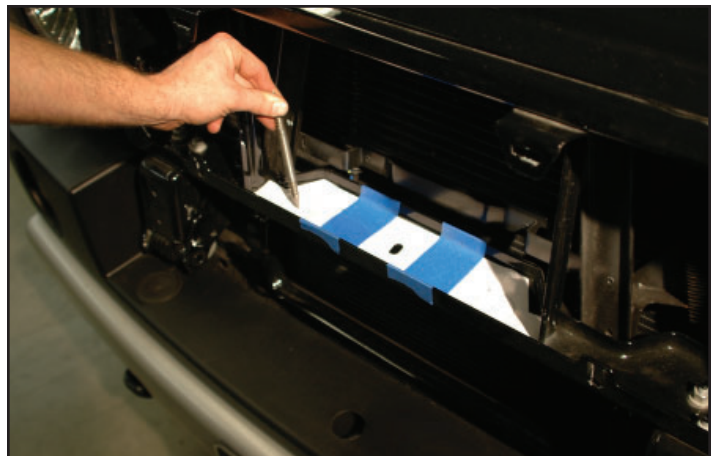

97. Drill the two 1-1/2" to 1-5/8" holes using the template marks in the bottom of the grille shell support.

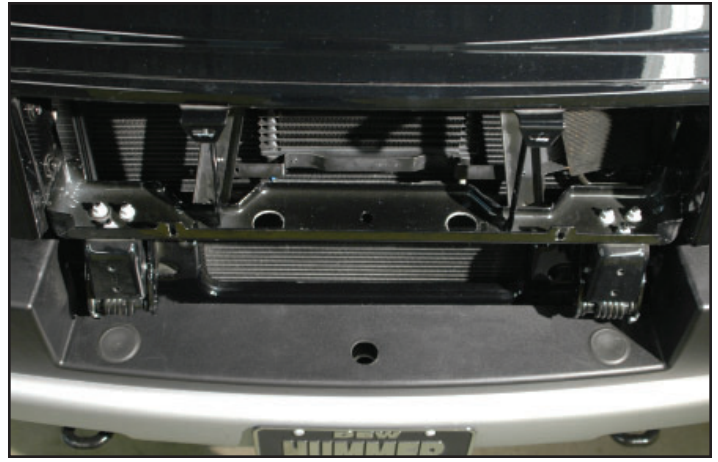

98. Here is the heat exchanger and its mounting components.



99. Place a 1/4" shim in the tray temporarily and slide the intercooler into position through the holes you just created in the grille shell. Use the mounting hole flanges to mark the four mounting holes necessary in the vertical grille shell framework.

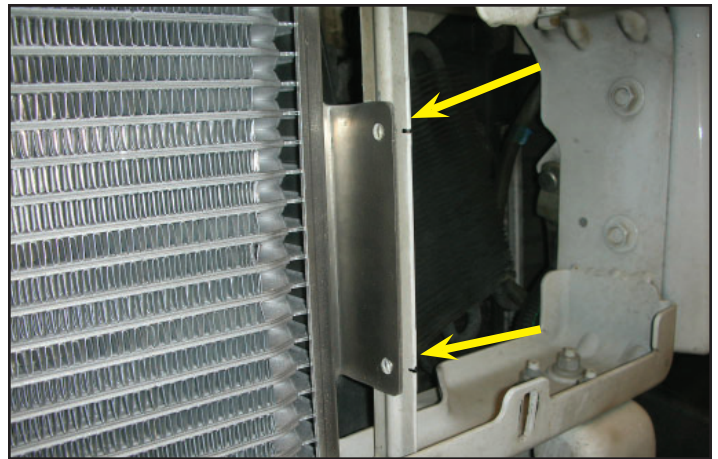

100. Drill 1/4" holes at the marks you just created.



101. Carefully install the heat exchanger into its mounting location. Secure the intercooler with the supplied nuts and bolts using a 10mm wrench.



102. Cut 2" off the short end of the provided 4" x 18" x 90° elbow hose. Install the hose just cut to run from the reservoir lower barb to the intercooler pump (installed in step 92) inlet barb on the top of the pump. Tighten/locate the provided clamps which may vary from screw to spring type. Use a worm gear clamp at the reservoir location shown with a red arrow.

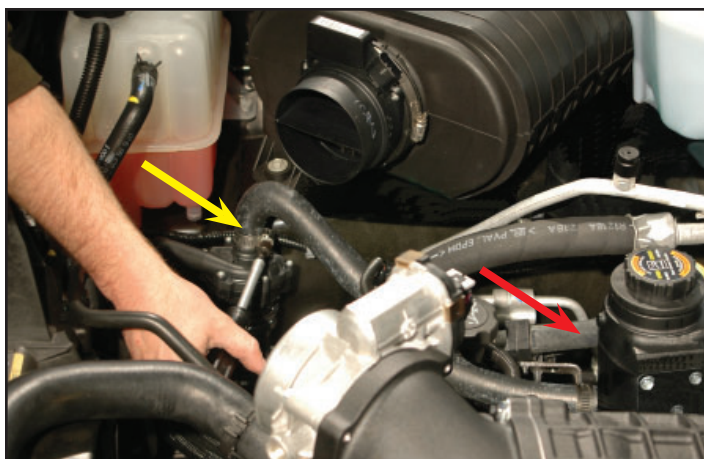

103. Cut a section of the provided 3/4" hose to 22-1/2". Install this hose from the reservoir barb to the passenger side intercooler barb. Route the hose under the 1/2" AC tube with the test/charge fittings, and behind the transmission dip stick. Tighten/locate the provided clamps which may vary from screw to spring type. Use a worm gear clamp at the reservoir location shown with a red arrow.

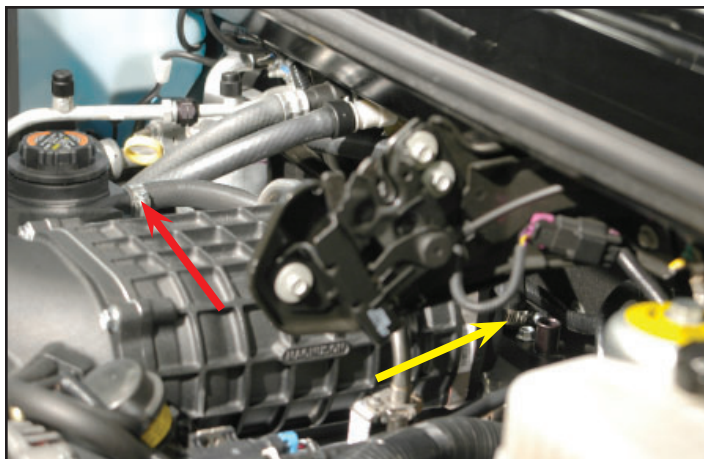

104. In preparation for the next intercooler hose: Remove the plastic push rivet on the passenger side plastic deflector panel toward the center end, in front of the radiator support structure, near the hood hinge as shown.



105. Pull up on the deflector and remove the foam transmission cooler-line vibration damper.



106. Cut a 2-1/2" section of the provided 5/8" hose. Attach one end to the driver side hose barb on the heat exchanger. Secure with the provided silver spring clamp. Cut a section of the provided 3/4" hose to 90" in length. Connect one of the provided 3/4" to 5/8" reducing couplings to the 5/8" hose with a provided black spring clamp. Connect the end of the 3/4" hose to the reducing coupling with a provided black spring clamp. Route this hose from the heat exchanger driver-side barb, behind the grille support frame in front of the radiators, through the grill support structure on the passenger side where the foam transmission cooler-line was removed into the engine compartment.

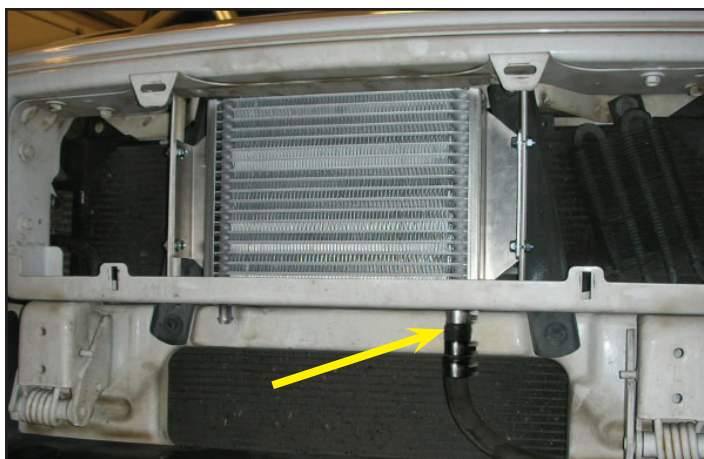

107. Cut a 2-1/2" section of the provided 5/8" hose. Attach one end to the passenger side hose barb on the heat exchanger. Secure with the provided silver spring clamp. Cut a section of the provided 3/4" hose to 42" in length. Connect one of the provided 3/4" to 5/8" reducing couplings to the 5/8" hose with a provided black spring clamp. Connect the end of the 3/4" hose to the reducing coupling with a provided black spring clamp. Route this hose above and parallel with the hose just installed through the same opening into the engine compartment.

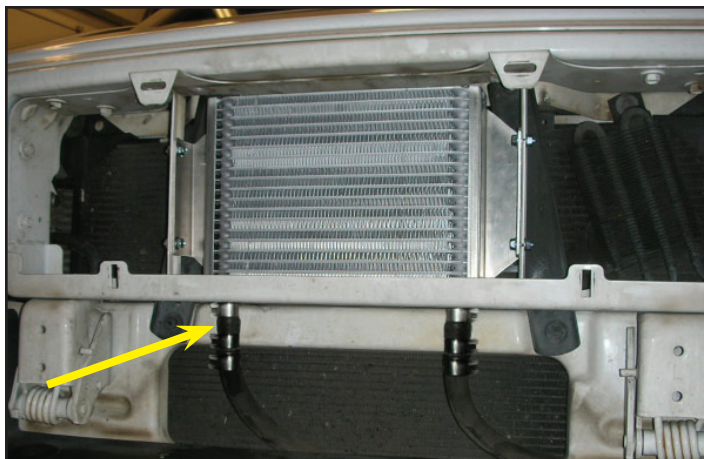

108. Ensure that the clamps have engaged the hose barbs adequately on the heat exchanger and the reducing coupling.

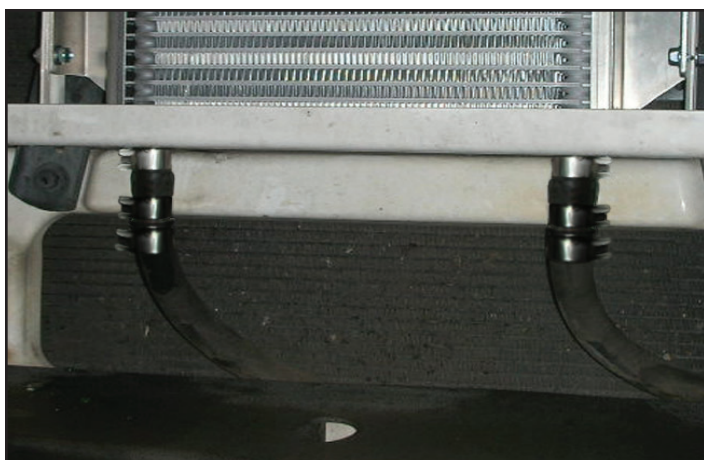

109. The other end of the 42" hose installed in step 107 is routed to the intercooler pump discharge barb. Tighten the #10 clamp provided firmly.

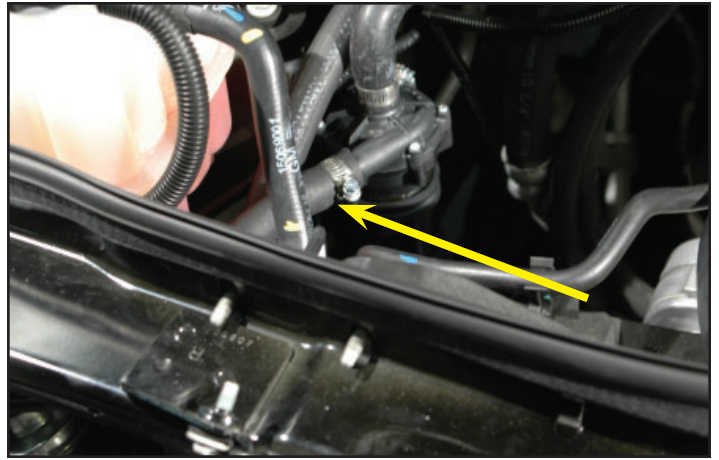

110. The other end of the 90" hose installed in step 106 is routed to the supercharger inlet barb located on the driver side, rear of the supercharger manifold. Tighten the #10 clamp firmly.

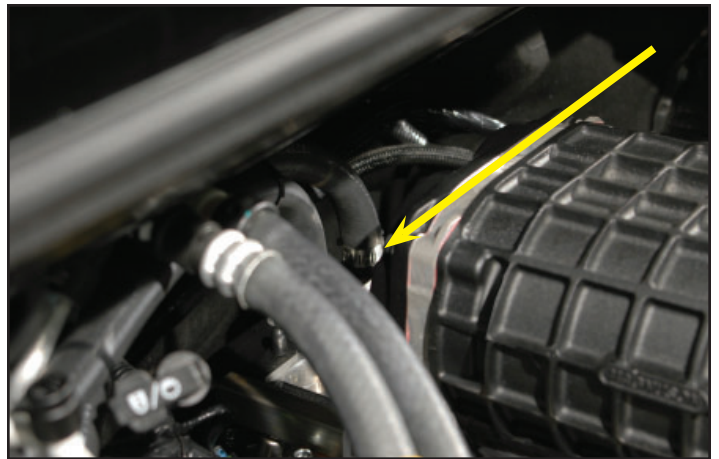

111. Cut the transmission line vibration damper removed in step 105 in half as shown.

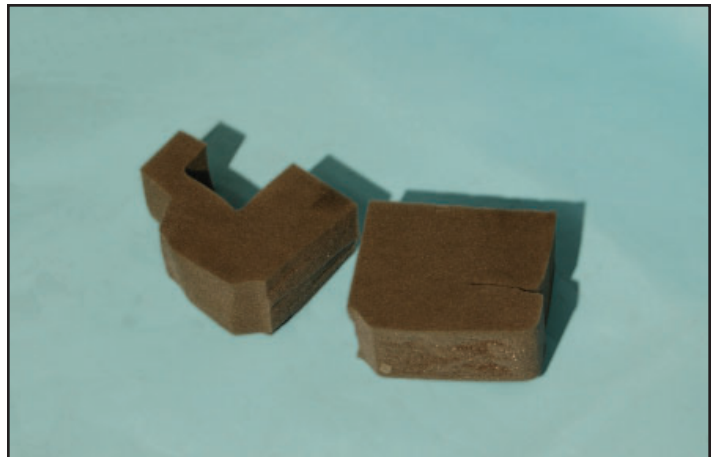

112. Pull up on the deflector shield on the passenger side (see step 104) and replace the (now) two pieces of foam back into place as they were originally removed.

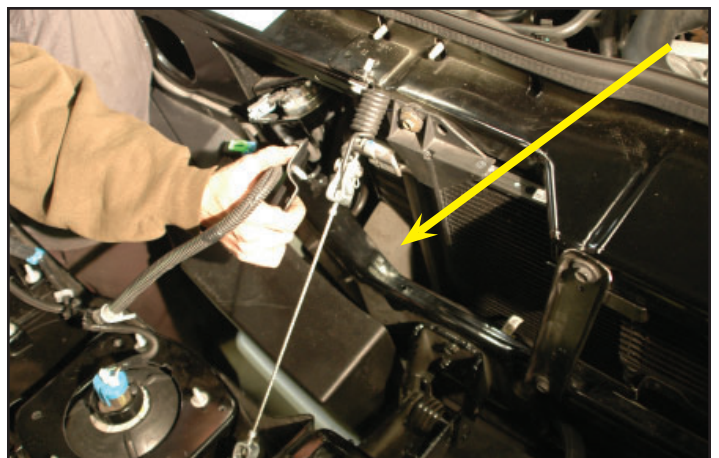



113. Replace the plastic push pin rivet holding the deflector in position.

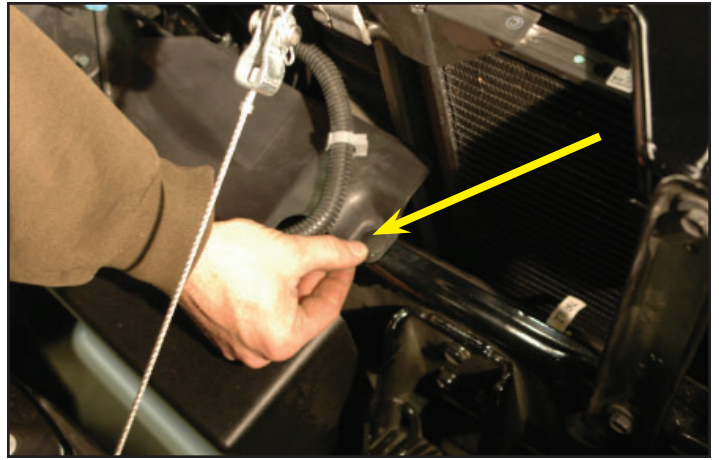

114. Using a 10mm socket wrench, remove the nut from the body ground stud on the firewall as shown.



115. Align the two plastic connection boxes of the intercooler relay as shown. Use a  $\frac{1}{4}$ " drill to create two enjoined mounting holes.



116. Locate the single black ground wire from the intercooler relay, shorten the wire to 7" in length, strip the insulation back  $\frac{1}{4}$ " from the end and then firmly crimp the ring terminal on the end.

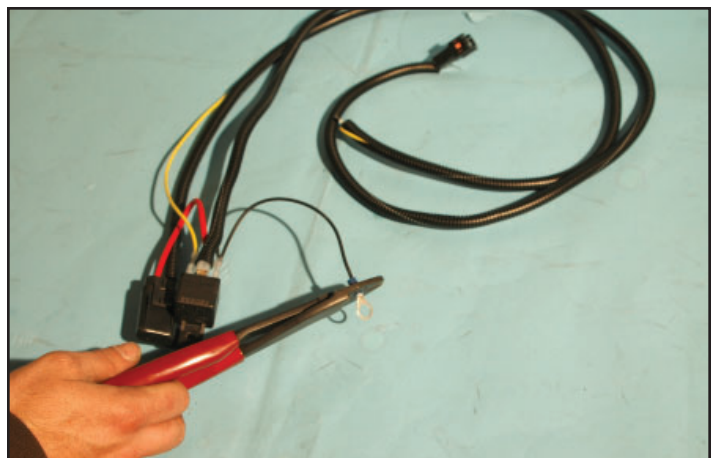

117. Install the black wire with its new ring terminal, over the existing ground wire on the body ground stud from step 114, and secure it firmly with the original nut.

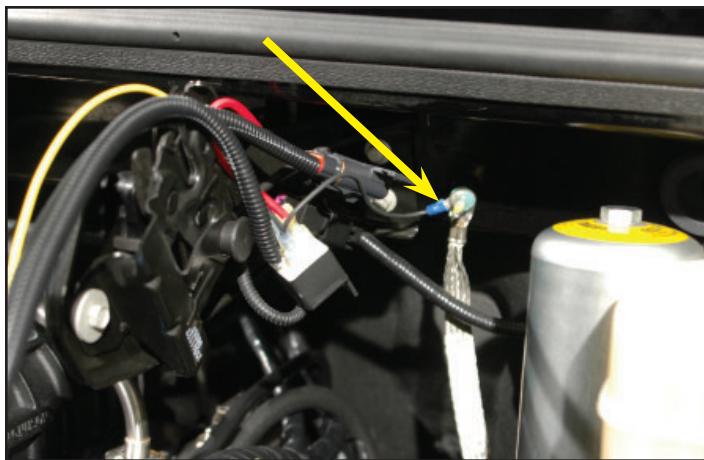

118. Align the holes of the plastic connection boxes from step 115, and install over the two body ground wires just referenced. Install the provided nut, mounting the two boxes to the firewall.

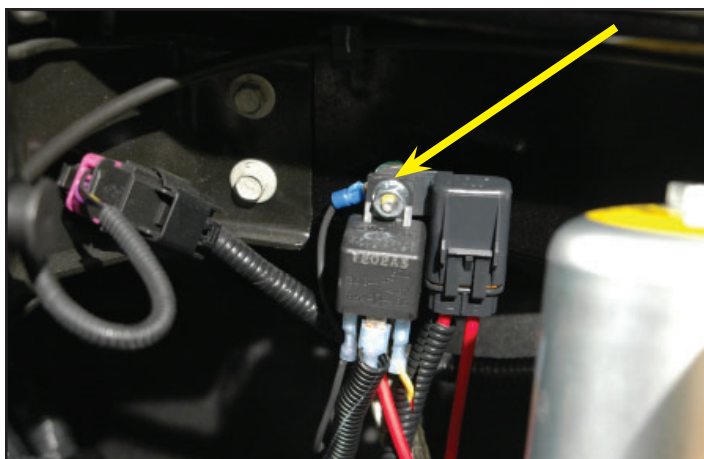

119. Route the long wire loom of the intercooler relay between the fuel line/fuel rail behind the supercharger, along side the heater hoses and plug into the intercooler pump as shown.



120. Remove the fuse center cover by pressing on the front lock tab and unsnap from the rear.



121. Route the remaining wire loom with the red and yellow wires of the intercooler relay behind the brake booster, along the engine side edge of the fuse center, in and up at the middle of the fuse center box bottom edge, into the fuse center itself.



122. Cut 4" off the yellow lead, strip 1/4" and crimp on the smaller of the supplied spade connectors.

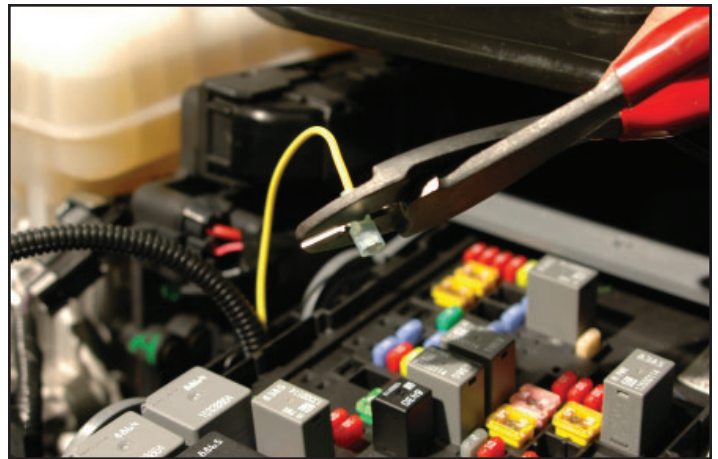

123. Remove the 10Amp HVAC IGN fuse. Check with the fuse map to verify location.

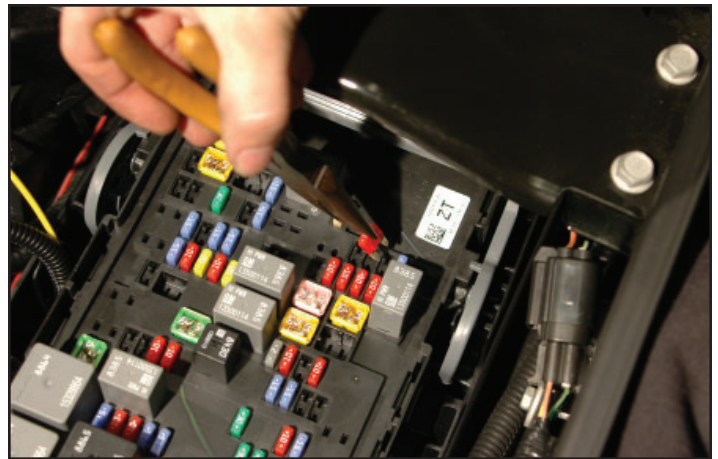

124. Install the provided fuse tap onto one leg of the fuse.

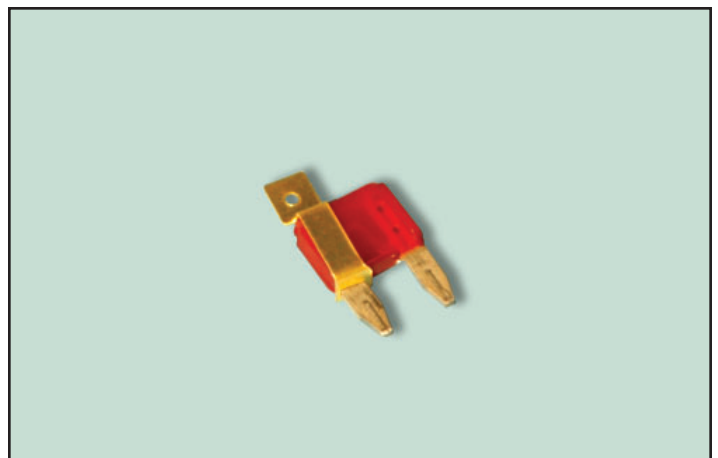

125. Reinstall the HVAC IGN fuse in its original location, and plug the yellow wire spade connection onto the fuse tap installed in the previous step.

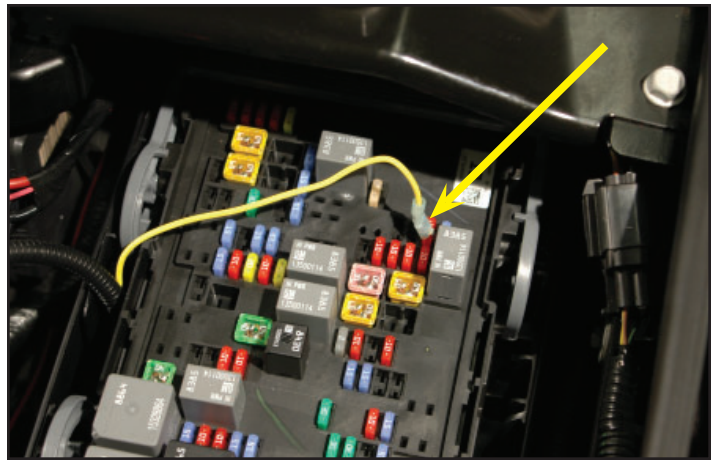

126. Cut off the existing connector and 1-1/2" from the red wire. Strip back 3/8" of the insulation and crimp on the larger of the supplied spade connectors.

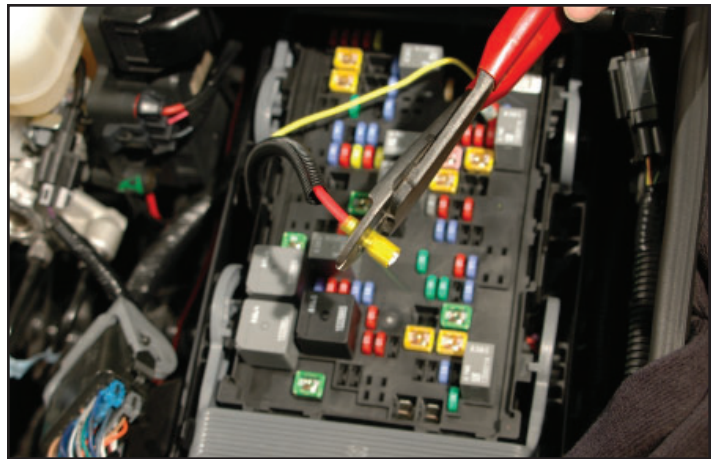

127. Press the spade connector just installed onto one of the back two spade terminals on the front end of the fuse center.

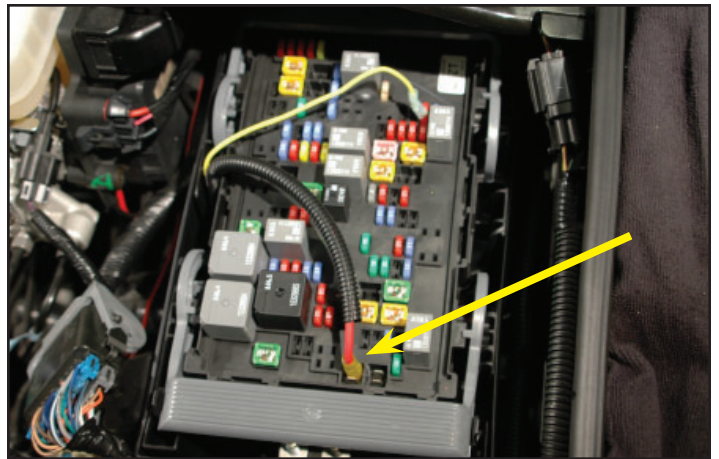

128. Reinstall the fuse center cover.

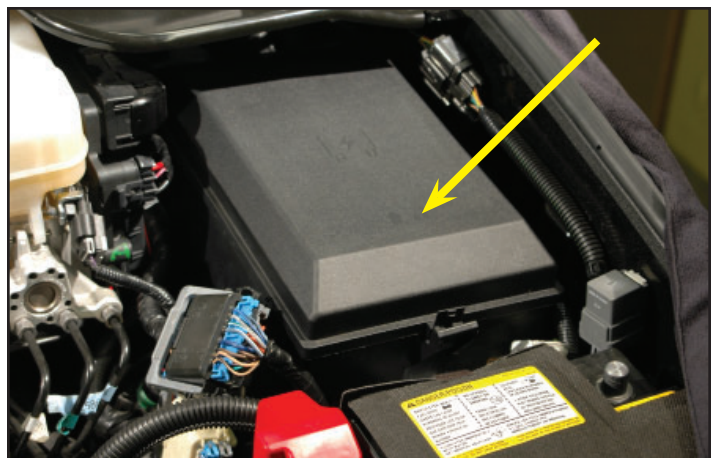

129. These are the air tube components.



130. Use some Teflon sealer or Teflon tape to coat/wrap the threads of the brass 90° fitting. Install the fitting in the air tube threaded hole with the barb pointing at approximately 2:00 from a bottom view, as shown in this picture.



131. Install the air bellows on the short angle of the air tube, and the throttle body rubber seal on the long end. Install the three clamps supplied. Tighten the clamp on the air tube end of the bellows. Push the bellows onto the air box, and tighten the clamp after checking the fit dynamics and clamp access of the assembly. Now push the throttle body end of the air tube into position and tighten the final clamp.



132. Plug in the MAF sensor at the air box.

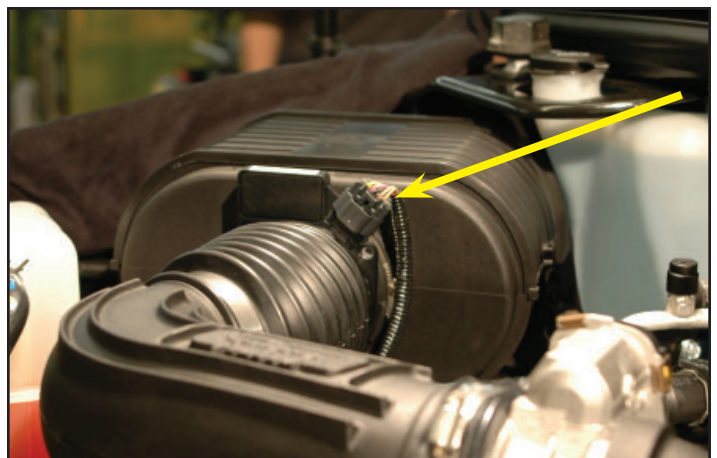

133. Cut a section of 3/8" hose provided to 8" in length. Push one end on the 90° barb installed in step 130 which is now located on the bottom of the installed air tube.

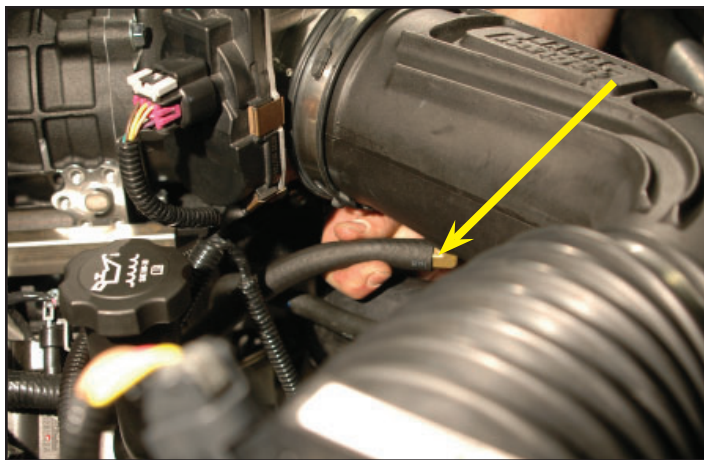

134. Plug the other end of the hose just installed into the barb located at the front of the passenger side valve cover.

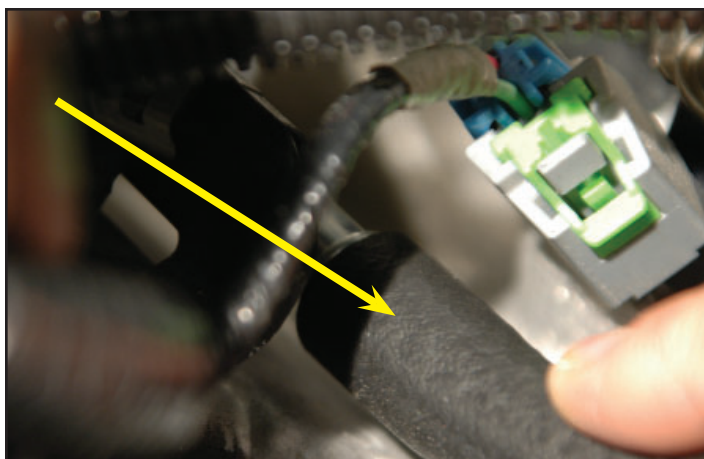

135. These next six steps are bench shots for clarity. Remove the bypass hose from the supercharger inlet hose barb.



136. Carefully pull the other end of the hose off of the bypass actuator hose barb. Ensure that the brass fitting at the tip of the barb remains on the bypass actuator hose barb tube as shown.



137. Press the supplied barb cap onto the hose barb of the supercharger inlet where you removed the bypass hose.



138. Install the new provided bypass hose onto the bypass actuator vacuum hose barb where the hose was removed.



139. Route the hose back along the supercharger to the rear of the supercharger on the passenger side. Remove the existing cap from the hose barb as shown.



140. Plug the remaining end of the new bypass actuator hose onto the hose barb you just exposed.



141. In step 95, you removed the grille. Separate the black section of the grill from the chrome fascia by using a large screwdriver to spread the locking clips. While these clips are spread use a pair of pliers to extract the clip. After the clips are removed the black extrusion section of the grill can be lifted away.

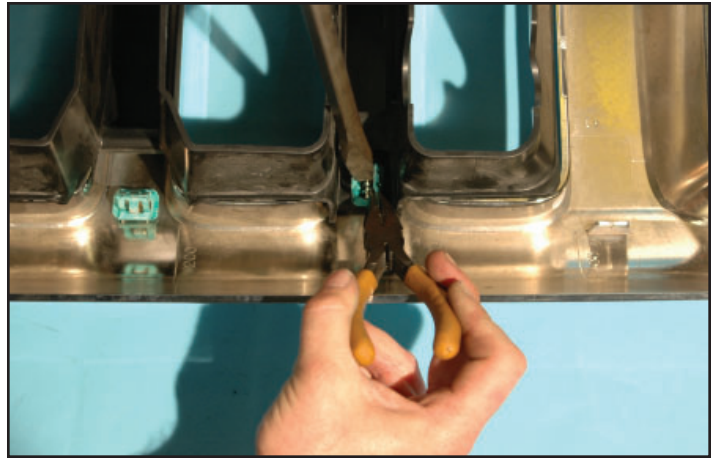

142. The three center extrusions of this black grille section need to be modified to create clearance with the newly installed heat exchanger. On what is the top surface, measure 5/8" down from butting the plastic lip as shown and make a mark at the outside end of the three center extrusions.

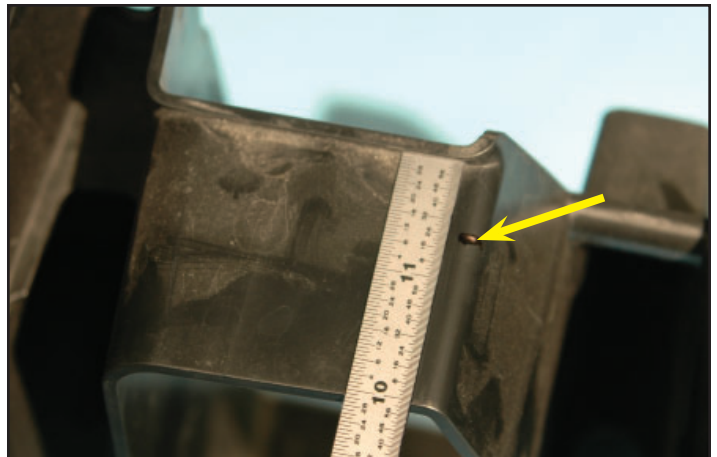

143. Using a straight edge draw a line between the two marks as shown. This defines the top cut line of what must be removed.

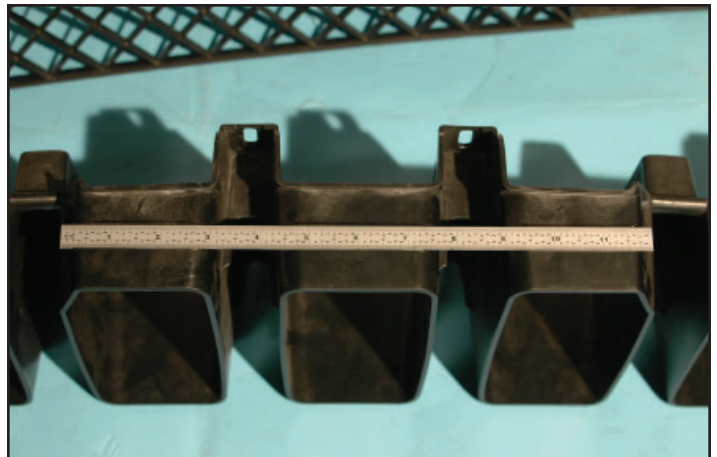

144. Flip the black section over so that the bottom side is now visible. The same three grille sections need to be marked here. Make a mark at the ends, this time measuring down 1-1/8" from the existing lip as shown.

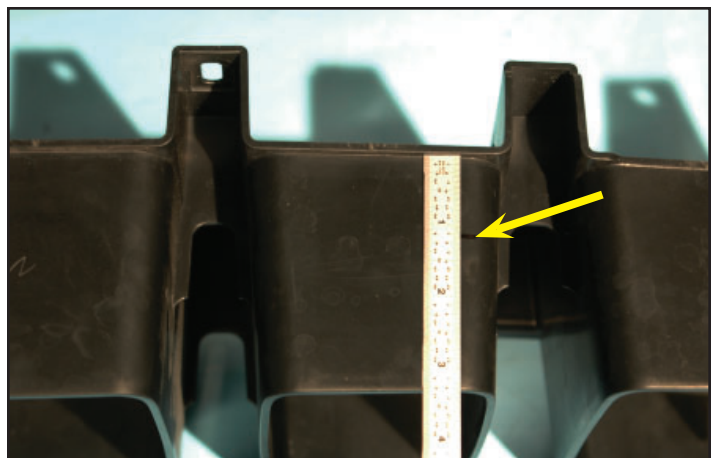



145. Using a straight edge draw a line between the two marks as shown. This defines the bottom cut line.

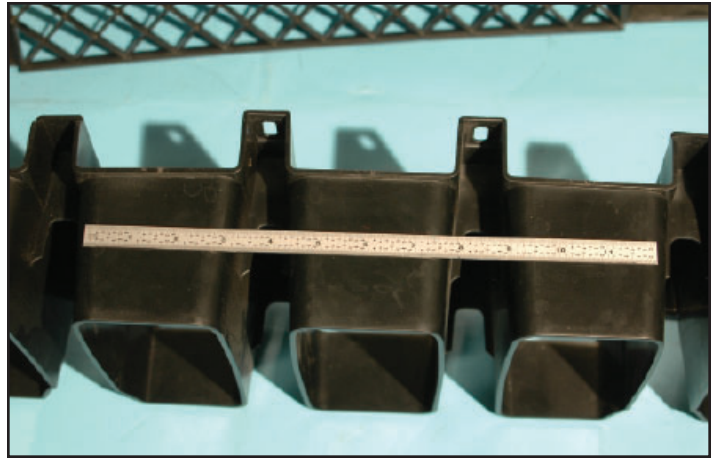

146. Use a band-saw, cutting wheel (shown), Dremmel, hack saw, table saw (or what have you) to cut these lines first. **DO NOT extend the cuts beyond into adjacent cells, only the three center cells need to be modified. NOTE: If you're using a band-saw you can skip the next two steps.** In this instance, connect the top and bottom cut lines to determine the angle required, place a spacer as necessary to maintain the cut line angle needed, slide the blade between the end cells of the cut and just push the entire piece through in one cut.



147. You need to place a piece of tape on the inside of the cells to be cut to create a visible line to follow. Use a straight edge slid between the top and bottom cuts you just made and draw a line as shown. Now take the cutting wheel (or hack saw blade, Dremmel etc.) and connect the top and bottom cuts to remove the pieces.

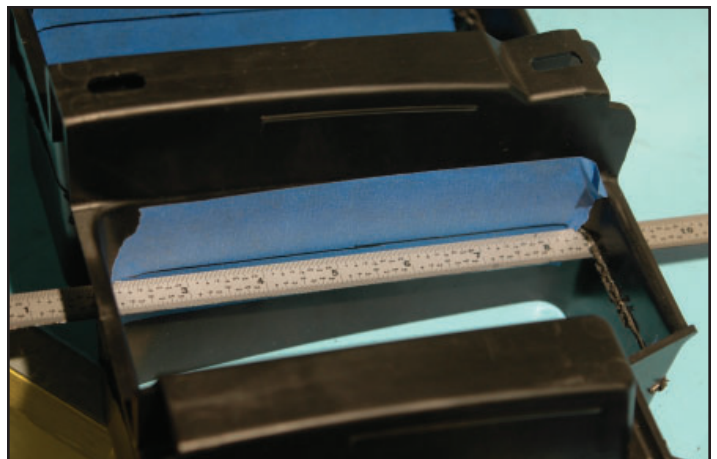

148. Remove the tape, clean up the edges and re-install the black extrusion cells onto the factory grille. Press the retaining clips back on to secure the pieces together. Your final grille should look something like this.



149. As an optional suggestion: Rattle can the heat exchanger flat black to reduce visibility.



150. Slide a length of the provided split loom over the heat exchanger hoses where they pass over the grill support to protect the hoses from chaffing.

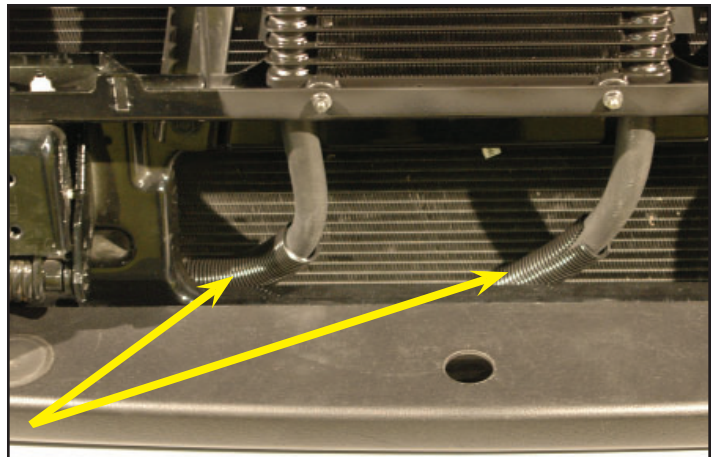

151. Reinstall the grille first by just pressing the grille into place engaging the snap connections.



152. Replace the four (two each side) nuts at the outside of each turn signal securing the grille to the hood.



153. Reconnect the battery negative (-) terminal.



**Make sure that you have followed step #1 in this manual to load the proper supercharger calibration to your vehicle's ECM.**

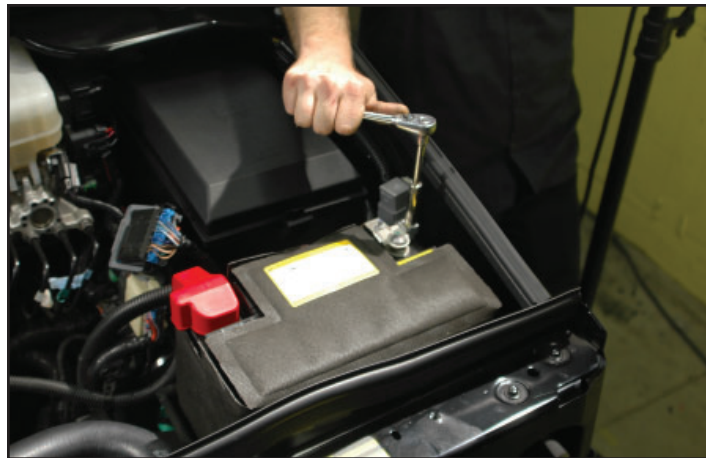

154. Fill the intercooler reservoir with the vehicle manufacturer recommended coolant mixture. Have an assistant temporarily key the vehicle on to turn the pump on. **Do not start the engine!** Key vehicle off after 5 seconds. Fill reservoir full again and continue this process until fluid is circulating. Fill the reservoir to the top of the upper barb. At this time check engine and supercharger for any leaks. Replace any brush guard/pull bars removed earlier.



155. Start the vehicle for five seconds and shut off. Once again, check for fuel leaks, fan-supercharger belt alignment, radiator, and intercooler reservoir. Top off as necessary



156. Test drive vehicle for the first few miles under normal driving conditions. **Do not perform any wide open throttle runs.** Listen for any noises, vibrations, engine misfire or anything that does not seem normal. The supercharger does have a slight whining noise under boost conditions, which is normal. Check & bleed intercooler reservoir as needed.



157. After the initial test drive gradually work the vehicle to wide open throttle runs, listen for any engine detonation (pinging). If engine detonation is present let up on the throttle immediately. Most detonation causes are low octane gasoline still in the tank. Affix the Premium Fuel Only decal on the inside of the fuel fill door.

If you have questions about your vehicles performance, please check with your installation facility.



**After you finish your installation and road test your vehicle, please fill out the warranty registration. This can be found on our website.**

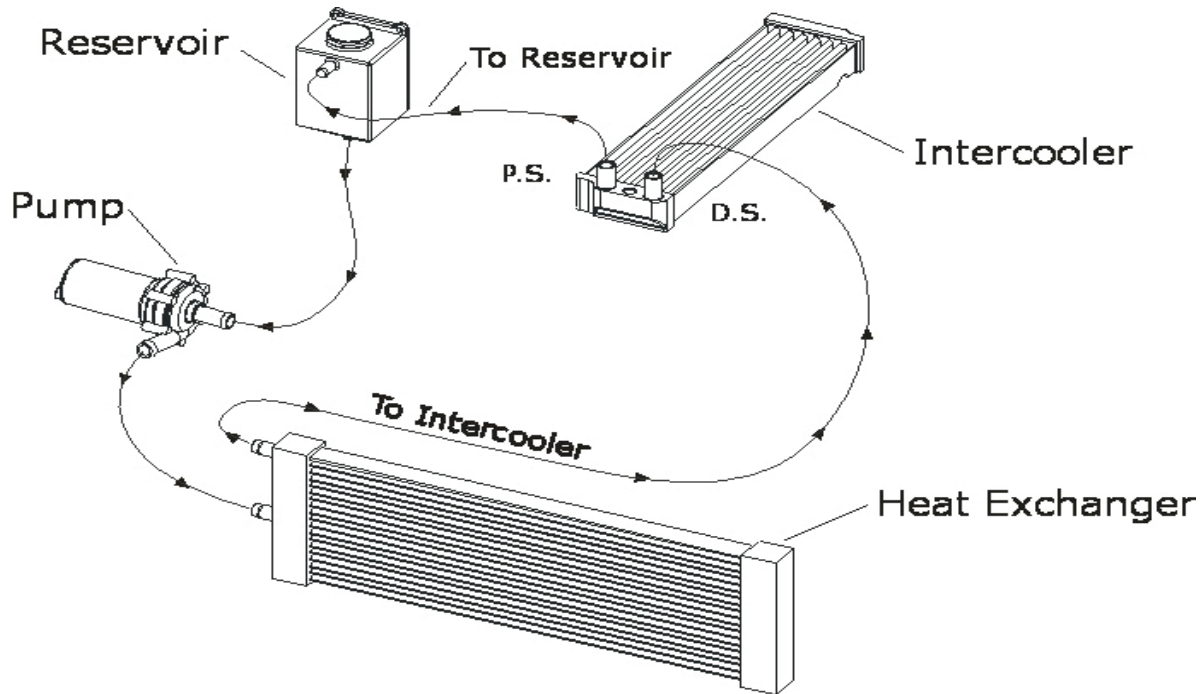

Intercooler plumbing diagram

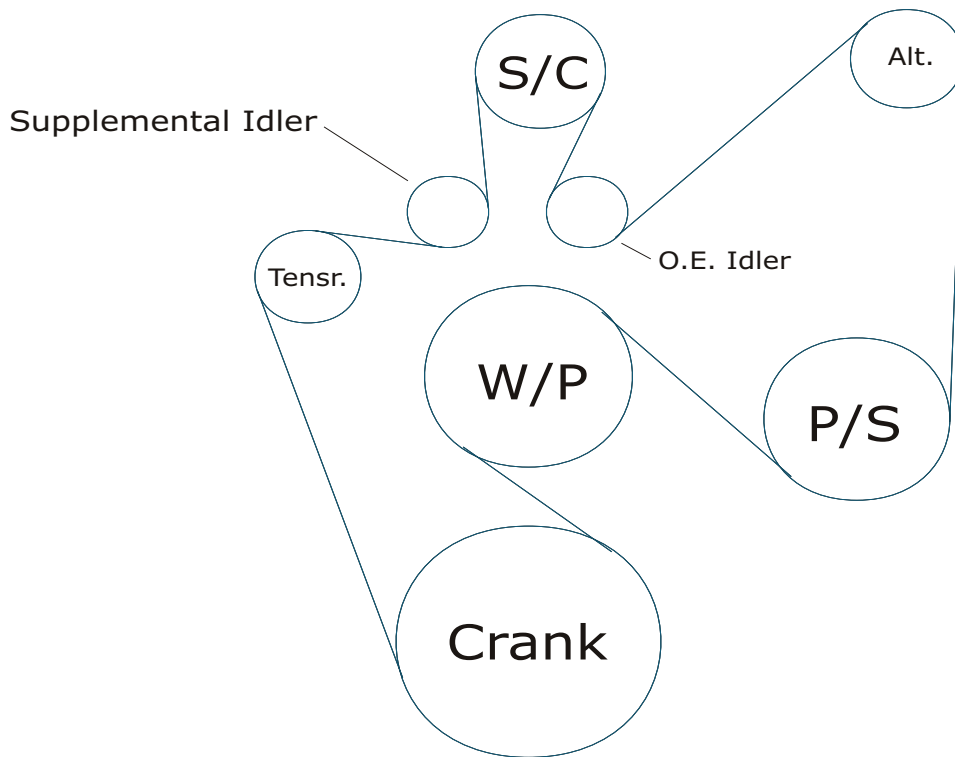

H2 Belt Routing Diagram

# NOTES

# NOTES



If you have questions about your vehicles performance, please check with your installation facility.

**This supercharger system requires the use of only premium gasoline fuel, 91 octane or better. It is NOT compatible with E85, Ethanol, Flex Fuels.**

**NOTE: Your supercharger system is sensitive to corrosion. You must use the vehicle manufacturer specified coolant mixture in the intercooler system as well as your radiator.**

Please enjoy your “Magna Charged”  
performance responsibly!

**MAGNUSON**  
*SUPERCHARGERS*