

MAGNUSON

SUPERCHARGERS

Installation Instructions for:
INTERCOOLED SUPERCHARGER SYSTEM
2009 PONTIAC G8 GXP



Step-by-step instructions for installing the best in supercharger systems.

*** PREMIUM GASOLINE FUEL REQUIRED ***

ATTENTION!



Your **MAGNUSON SUPERCHARGER** kit is sensitive to corrosion!
Use only the vehicle manufacturer recommended coolant for your engine in the intercooler system as well.

89-89-60-020 Rev E

Magnuson Superchargers
1990 Knoll Drive, Bldg A, Ventura, CA 93003
(805) 642-8833
magnusonsuperchargers.com

INSTALLATION MANUAL

Magnuson Superchargers Kit GM 6.2L Engine 2009 Pontiac G8 GXP

Please take a few moments to review this manual thoroughly before you begin work. Make a quick parts check to be certain your kit is complete (see shipper parts list in this package). If you discover shipping damage or shortage, please call our office immediately. Take a look at exactly what you are going to need in terms of tools, time, and experience. Review our limited warranty with care. When unpacking the supercharger kit **DO NOT** lift the supercharger assembly by the black plastic bypass actuator. This is pre-set from the factory and can be altered if used as a lifting point!

Caution: Relieve the fuel system pressure before servicing fuel system components in order to reduce the risk of fire and personal injury. After relieving the system pressure, a small amount of fuel may be released when servicing the fuel lines or connections. In order to reduce the risk of personal injury, cover the regulator and fuel line fittings with a shop towel before disconnecting. This will catch any fuel that may leak out. Place the towel in an approved container when the job is complete.

NOTE: This supercharger system requires the use of only premium gasoline fuel, 91 octane or better. It is NOT compatible with E85, Ethanol, or Flex fuels.

Magnuson Superchargers recommend that you run a minimum of one (1) tank of premium fuel through your vehicle prior to installation of the system to prevent any possible damage that may occur due to running the supercharged engine on lower octane fuel. **DO NOT add octane booster to your vehicle.**

Our Magnuson Supercharger kits are designed for engines in good mechanical condition only. Installation on high mileage or damaged engines is not recommended and may result in engine failure, for which we are not responsible. Magnuson Superchargers is not responsible for the engine or consequential damages.

Magnuson Superchargers kits are designed for use on stock vehicles. To that end, the alteration or modification of the fuel system, drive train, engine, and/or supercharger outside of stock parameters in any way can result in engine damage or failure for which Magnuson Superchargers is NOT responsible and will void Magnuson Superchargers warranty and CARB certification. Aftermarket engine recalibration devices that modify fuel and spark curve (including, but not limited to programmers) are not recommended and may cause engine damage or failure. Use of non-Magnuson Superchargers approved programming will void all warranties. If you have any questions, call us.

A new GM fuel filter is recommended at the time of supercharger installation

Stock spark plugs and stock plug gap are recommended

Drive belt = Gates# K060878

Tools Required:

Metric wrench set

1/4" - 3/8" and 1/2" drive metric socket set (Standard & Deep)

3/8" and 1/2" drive foot pound and inch pound torque wrenches

Phillips and flat head screwdrivers

Fuel line quick disconnect tools (included in kit)

Small or angled 3/8" drill motor

Drain pan

Hose cutters

Hose clamp pliers

Safety glasses

Metric Allen socket set 3/8" drive

Shop vacuum cleaner

Helpful Tool: Air or electric impact wrench.

Contact information:

Magnuson Superchargers

1990 Knoll Drive, Bldg A

Ventura, CA 93003

Sales/Tech support 805-642-8833

Website:

www.magnusonsuperchargers.com

Email:

sales@magnusonsuperchargers.com

1. If your kit has a provided handheld tuner follow the instructions in the provided pamphlet to install your tune. Your handheld tuner may not match the one shown.



2. Your Intercooler system is sensitive to corrosion. It's very important to use the OEM recommended coolant mixture in your supercharger system as well.



3. Your system requires the use of minimum 91 Octane gasoline fuel. This system is **not** compatible with E85 fuel.

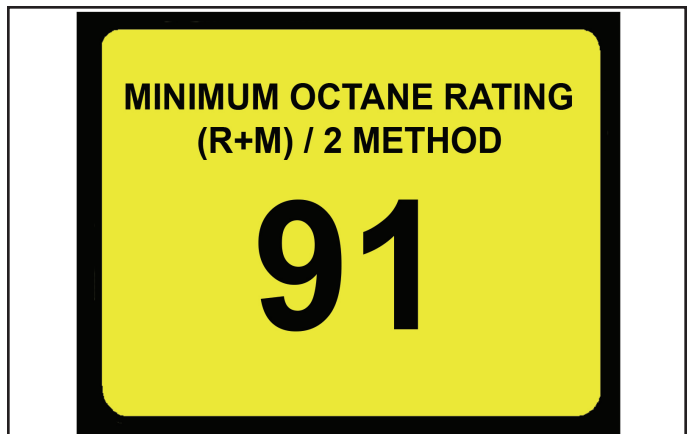

4. On the sidewall of the trunk on the driver side is an access panel behind which the battery is located. Pull off this access panel to expose the battery. Disconnect the negative battery terminal using a 10mm wrench.



5. Slowly remove the gas cap to release fuel system pressure.



6. Remove the engine cover by lifting and put aside. This will not be reused.



7. Place a drain pan under the passenger side front of the car. Using a medium Phillips screwdriver remove the cooling system drain plug from the bottom of the radiator on the passenger side. Facilitate the draining of coolant by removing the radiator cap. Reinstall the drain plug and radiator cap when draining is complete.

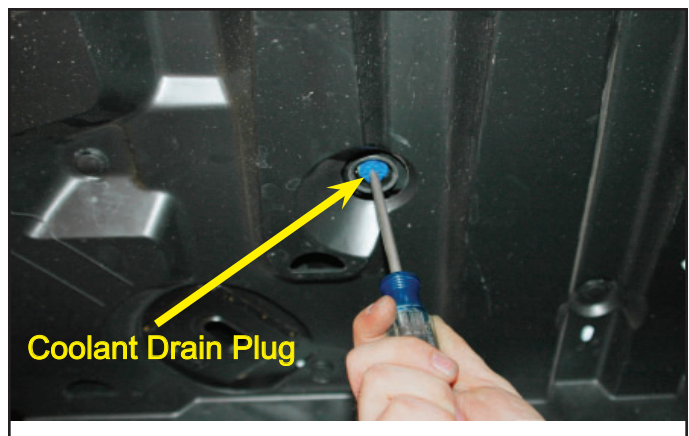

8. Disconnect heater hoses at the heater core and water pump (note: heater core hard-lines will flex). These hoses are banded together and go back to the firewall where you will find spring clips. Using a pair of pliers grasp the spring-clips and pull forward beyond the barb. Then pull the hoses free, be aware there could be fluid in the hoses. We suggest you wrap the hose barb with a shop towel to catch the dribble and keep clean. These hoses will not be reused.



9. Use a 7mm socket to loosen the clamps holding the air bellows to the MAF Sensor.



10. Depress the locking tabs on the PCV Vent tube on the passenger side hose barb and pull the connection free.

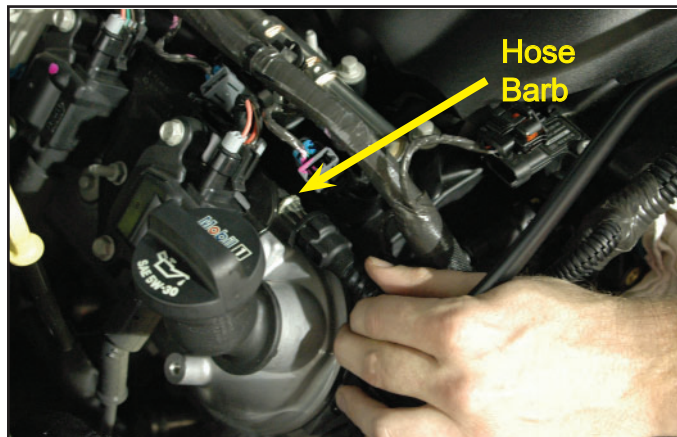

11. Use the 7mm socket to loosen the clamps holding the air intake tube to the throttle body and remove the air intake tube. This assembly will not be reused.



12. Disconnect the EVAP Solenoid plug.

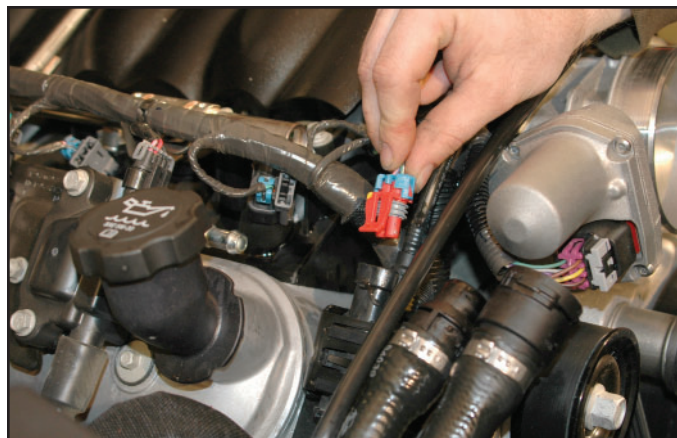

13. Disconnect the MAP Sensor plug.

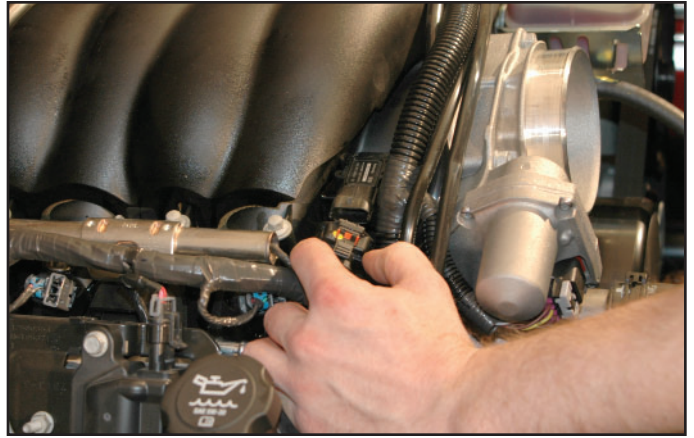

14. Disconnect the eight Injector plugs on each side of the engine.

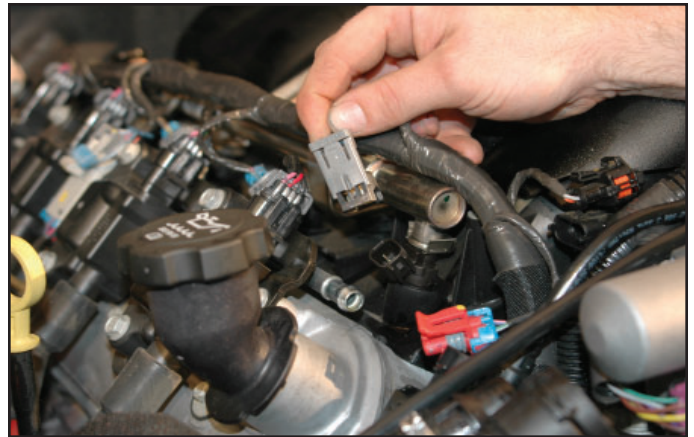

15. Pull the injector wire loom free from the stock intake manifold fuel rail mounting holes.



16. Remove the EVAP link by squeezing the yellow saw-tooth tabs and pull free from both ends, put aside for later use.



17. Remove the end of the PCV hose from the intake manifold on the passenger side by squeezing the locking tabs and pull free. This will not be reused.

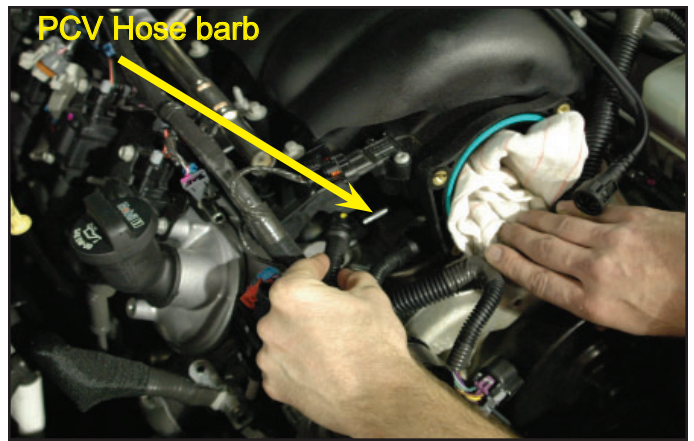

18. Depress the light gray (almost white) tabs of the EVAP tube outlet from the EVAP Solenoid and pull free from both ends, put aside for later use.

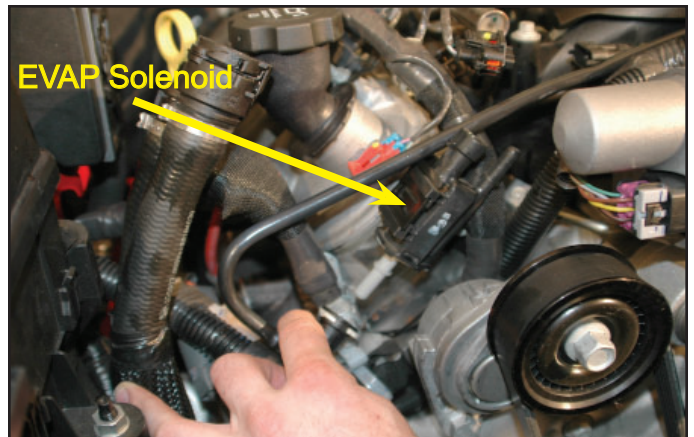

19. Unplug the throttle body control by pulling out the gray tab and pull free.



20. Unbolt the four bolts of the throttle body using a 10mm socket wrench and remove the throttle body, put aside for later use.



21. Pull the vacuum brake hose free from the power brake booster.



Wear safety glasses while working with fuel lines. Place rags around the fuel line to catch draining fuel and dispose of these rags in an appropriate container.

22. Pull off the retaining clip, and using the fuel line removal tool supplied, remove the fuel line to the drivers side fuel manifold. To ease removal, pull the fuel line forward, then insert the disconnect tool. Then push the fuel line back, removing it from the manifold. If you have or can improvise a cap we suggest you cap both the hose and the manifold to avoid spillage.

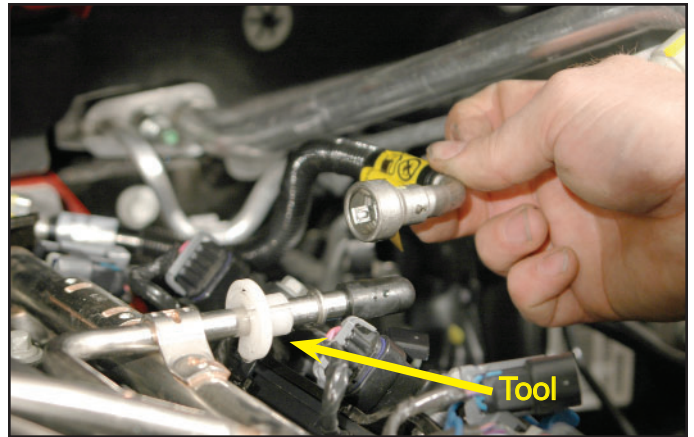

23. Unbolt the intake manifold using an 8mm socket wrench. There are five bolts on each side.



24. Remove the stock intake manifold and put aside, you will be taking some parts off from the bench.



25. Carefully vacuum the valley cover and the just exposed port surfaces first. Then wipe the heads clean of oil and any debris using a solvent dampened rag. Unplug the remaining PCV hose from the front passenger side of the valley cover hose barb. Finally, tape over the intake ports. It's important to maintain a clean work environment.

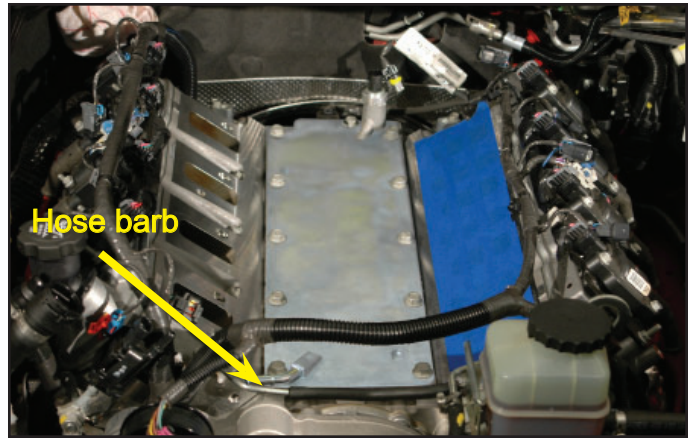

26. For these next few steps, you may find it easier (and you will have more room), if you first remove the front wheel. Pull the push pins of the front panel fender wells out (four each side), and pull the panels away.



27. For ease of work you can remove the remaining pins and completely take the fender well liners out completely, or you can just bend the panels out of the way as you work.



28. As the case may be, bend the panel toward the rear of the vehicle. Then use a 10mm socket to remove the two front end bolts on each side of the vehicle holding the front body panel to the upper fender section. This shows the fender well removed completely.



29. On the passenger side of the vehicle, front of the fender well, unplug the connector that splits to go to the parking lights (fog lights), and the side marker illuminating reflector.

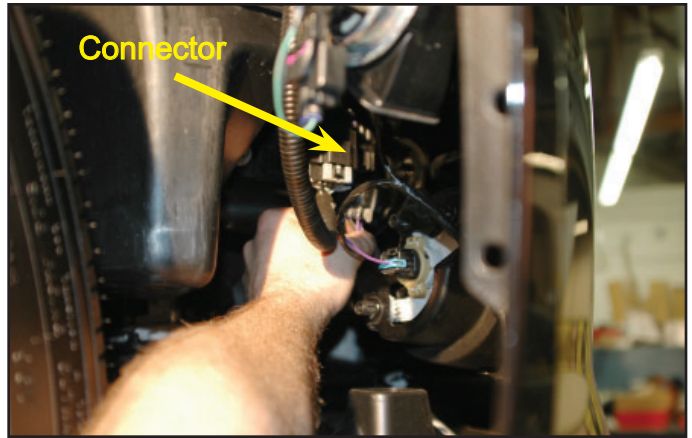

30. Remove the four 13mm bolts and the four 7mm bolts on the bottom plastic splash shield, then pull the bottom panel free by pulling aft and away from the front of the vehicle. Set aside for later use.



31. Remove the two push pins and two 10mm bolts from the top of the front end panel connecting the front end fascia to the upper radiator support.



32. Now, this is a little difficult, because it's blind. There are two plastic spring tabs under the headlamp on each side. Accessing from below through where the plastic skid panel was located, you reach up to just below the headlight housing on each side, as you reach up; the plastic has a forward edge bending slightly down. Feel along these plastic flanges and you will notice four slots on each side close together in pairs. Between these slots are the plastic spring tabs. This first picture shows you the tabs after the front panel is removed.



33. Pull down between the outer two slots on the spring tab while slightly pushing the body panel forward away from the vehicle. When the outer spring tab releases, do the same for the inside spring tab. Repeat on the other side of the vehicle. Be sure to have a helper handy for this step...you don't want the front end popping off and getting scratched when it slams to the ground. Pull the front end body panel free from the vehicle and put aside in a safe place where it won't be damaged.



34. Pull off the plastic 5mph bumper guard.

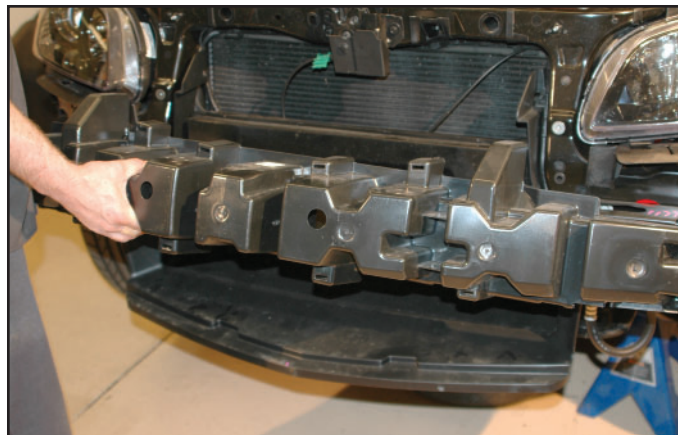

35. Unplug the MAF Sensor plug from the Air-box.



36. Unclip the five spring clips that hold the Air-box cover in place.

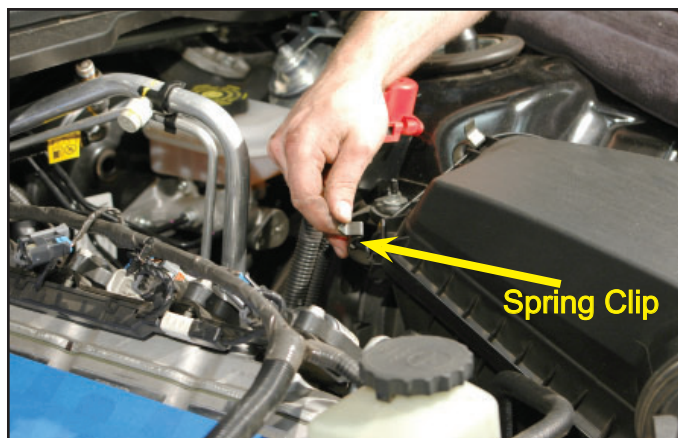

37. Remove the cover, put aside to reinstall later.



38. Remove the upper Radiator hose clamps from both ends of the hose, pull the hose off the hose barbs and put aside for later use.



39. Remove the coolant overflow tube from the hose barb just below the radiator cap, unclip from mounts and coil up on the passenger side of the vehicle out of the way.



40. Reroute the secondary coolant to crossover tube out of the way. You can bend it to run out the other side of the radiator cap.



41. Disconnect the Fan Plug from the Fan Shroud housing.



42. Push down on the top of the Transmission Heat Exchanger hoses so that they disconnect from the mounting clips of the lower Fan Shroud housing.

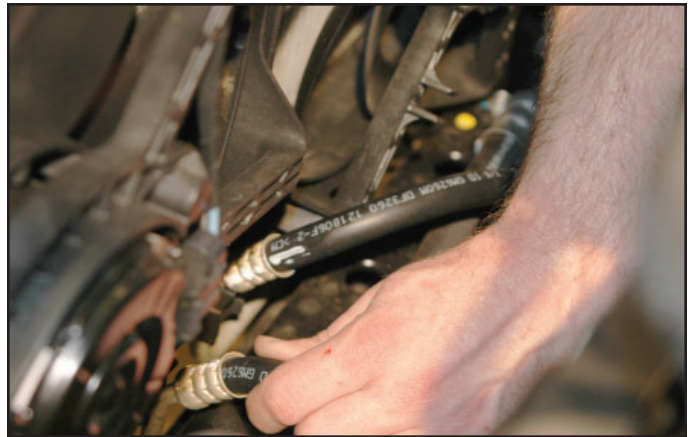

43. Using a medium flathead screwdriver, push down on the top locking pins to release the upper Fan Shroud mount.



44. Pull the Fan Shroud assembly free from the vehicle and put aside for later re-installation.



45. Remove the mounting bolts from the transmission cooler hard-line bracket at the driver side frame crossover with a 13mm socket.

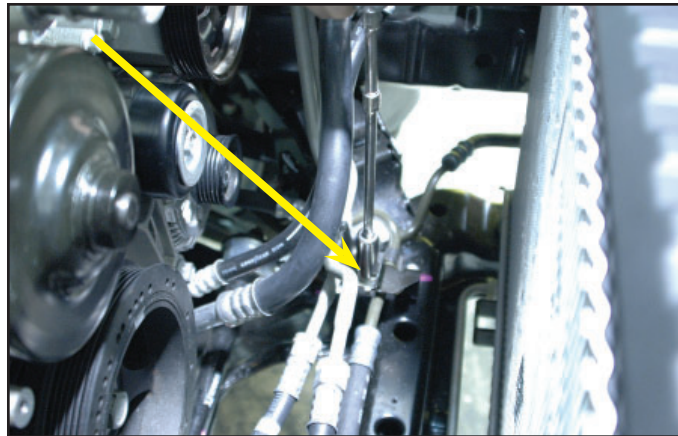

46. Remove the transmission cooler hard-line mounting bracket bolt from the driver side frame rail using a 10mm socket.

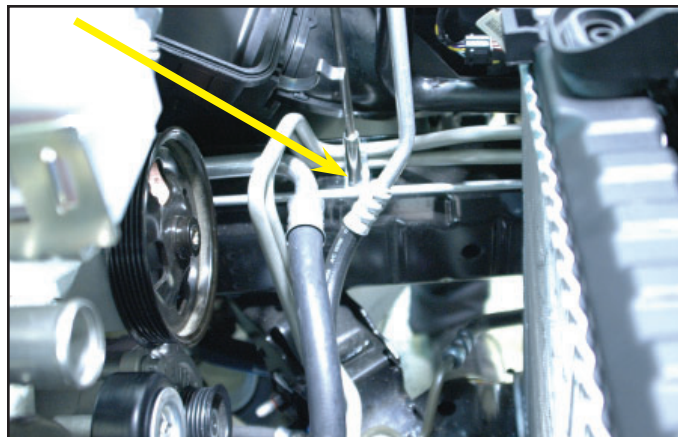

47. Using a 24mm socket and an impact hammer, remove the Main Harmonic Balancer bolt. This will not be reused. Sometimes using a heat gun or MAP gas torch on the surrounding pulley material helps it to break free from the Loctite used during initial installation. **Don't heat the bolt itself and always use care using open flame around engine compartments and combustible material.**



48. Install the supplied drill guide using the supplied bolt and tighten to 30 ft-lbs with a 24mm socket and torque wrench.



49. Using a small or angled 3/8" drill and the supplied drill bit, insert the drill into the two guide holes and drill to the second step of the drill bit. Be sure that you drill all the way to the second step, and use with suitable cutting oil. **(Caution: Wear safety glasses)**

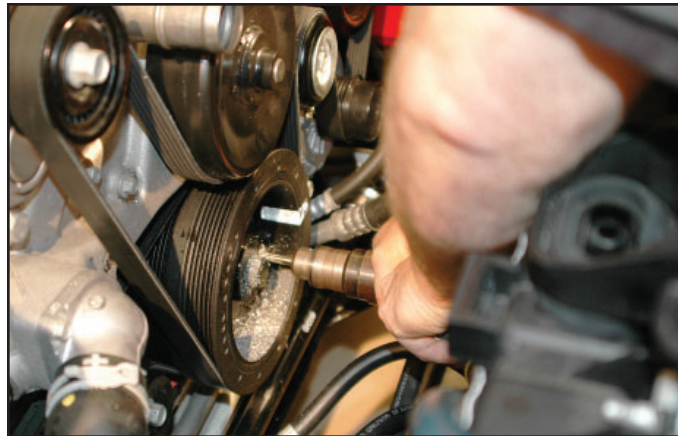

50. Using compressed air, blow the drill shavings out of the holes. **(Caution: Wear safety glasses, and make sure that debris doesn't blow into surrounding openings...such as the thermostat housing etc.)**



51. Insert the supplied reamer into the drill, and using a small amount of oil, ream the holes clean until reamer bottoms out in the holes. **(Caution: Wear safety glasses)**

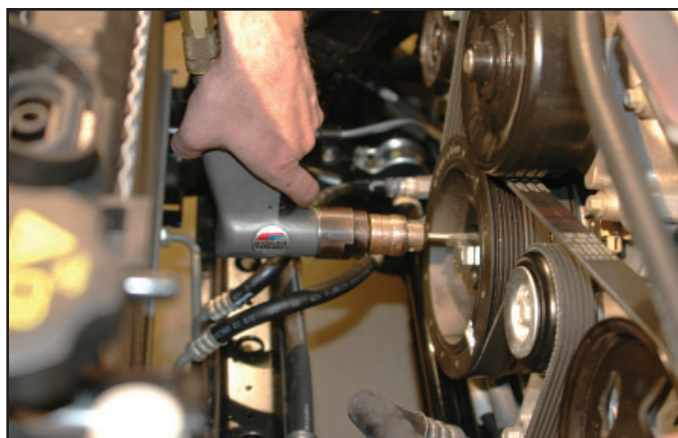

52. Using a 24mm socket, remove the large bolt and drill guide from the engine.



53. Once again, use compressed air to blow out the holes. **(Caution: Wear safety glasses and again be aware of surrounding openings.)**

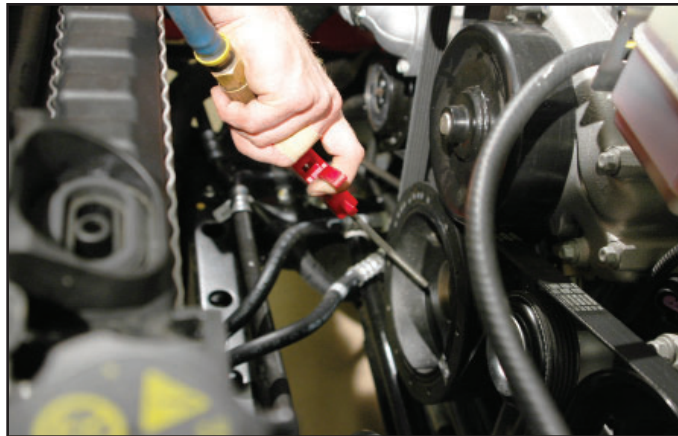

54. Insert the two supplied hardened roll pins into the drilled holes.

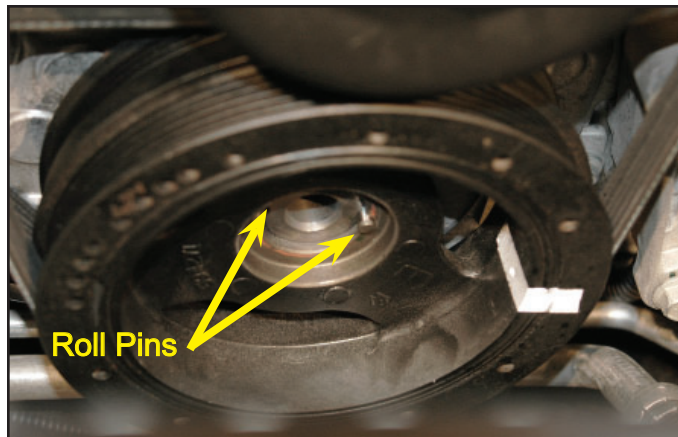

55. The use of a small hammer and punch may be necessary to tap the pins in. Make sure that the pins are in far enough that they do NOT touch the balancer bolt.

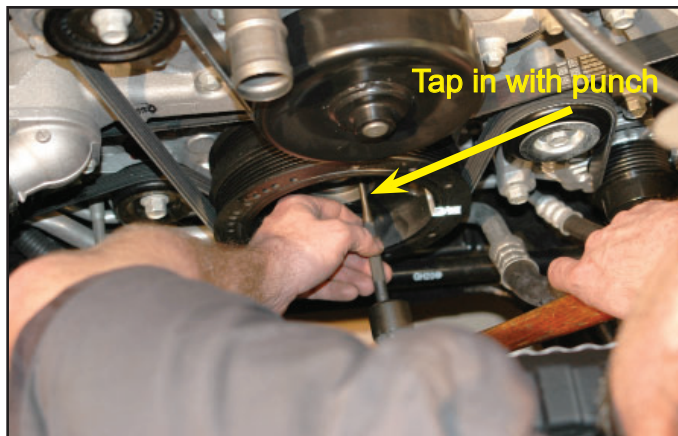

56. Install the new supplied factory GM Harmonic Balancer bolt.



57. Using a 24mm socket tighten the new Harmonic Balancer bolt according to General Motors specifications. Tighten to 50 N-m (37 ft-lbs) then tighten an additional 140 degrees using a torque angle meter.



58. Using a 15mm socket on the Tensioner Pulley bolt, spring the pulley down to remove tension on the drive belt and remove the belt when tension has been released.

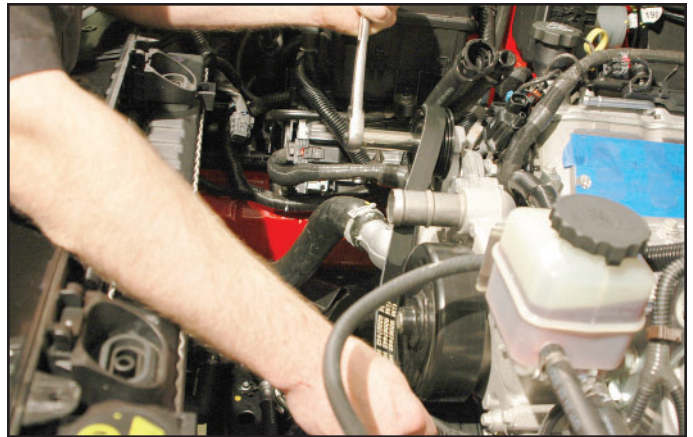

59. Disconnect the oil pressure sensor connection at the rear of the valley cover.

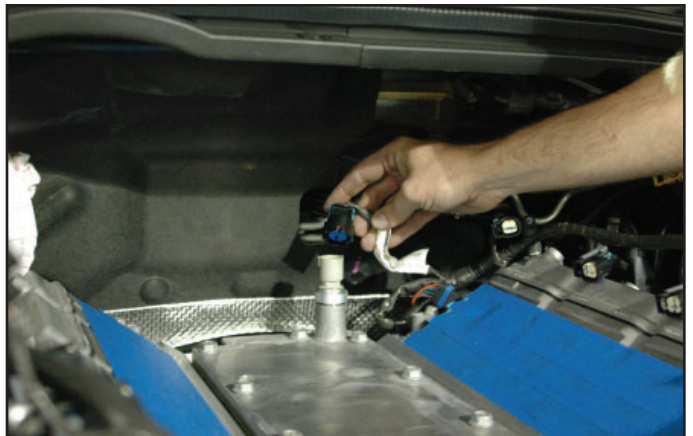

60. Remove the oil pressure sensor from the valley cover using a 6-point 1-1/16" socket or wrench, put aside for later re-installation.



61. Remove the eleven valley cover bolts using a 13mm socket and set aside.



62. Remove the OEM valley cover. This will not be reused, but we will need components.



63. Verify the integrity of the existing valley cover gasket, and that it is correctly positioned on the valley surface.



64. Remove the existing O-ring seals from the OEM valley cover, and place in the O-ring grooves of the new provided valley cover.

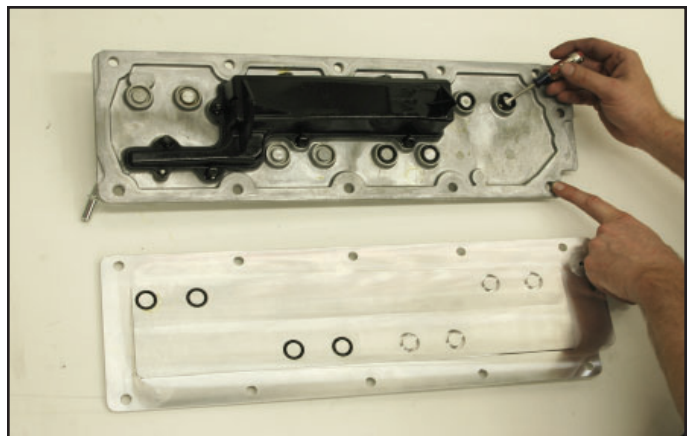

65. Install the new valley cover using the eleven provided Allen-countersunk bolts. Torque to 18 ft-lbs using a 5mm Allen socket. Verify your torque wrench settings.

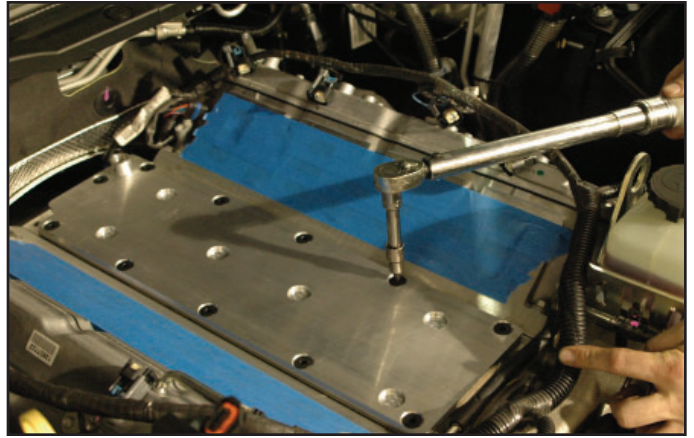

66. With the new valley cover in place, check the clocking of the oil pressure sensor. Temporarily install the oil pressure sensor and torque to 15 ft-lbs. If the plug locking clip is in the #1 or #2 position, no shim is needed. If it ends up in the #3 position, then use the provided shim. Now remove the oil pressure sensor.

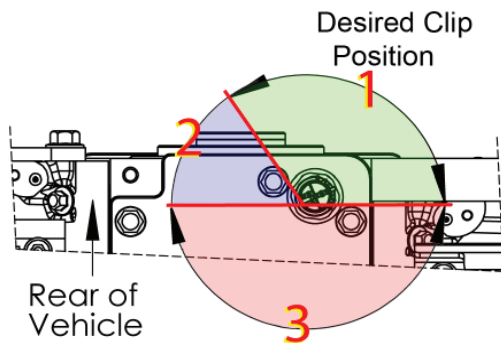

67. Permanently install the clocked oil pressure sensor. **IMPORTANT:** Apply some Teflon tape or paste to the threads to prevent oil leakage. See the prior step regarding shim position requirements: The sensor must be torqued to at least 15 ft-lbs, but you may have to torque your sensor up to 24 ft-lbs to reach the desired clip position.



68. Place a dab of some black silicone into the recesses of the top surface of the new valley cover to hold the six provided O-rings in place.

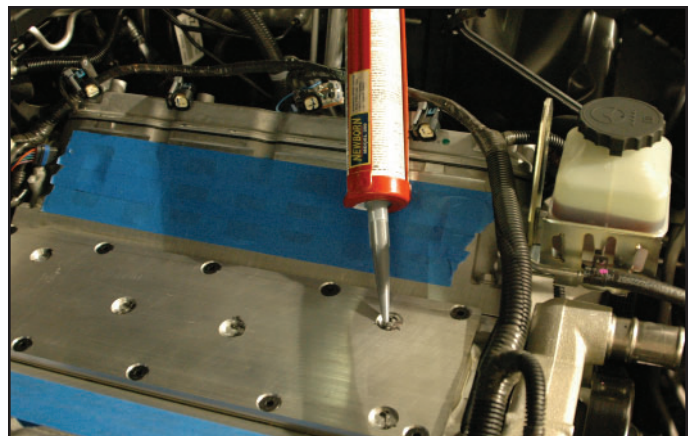

69. Insert the six provided O-rings into place on the top surface recesses of the new valley cover.

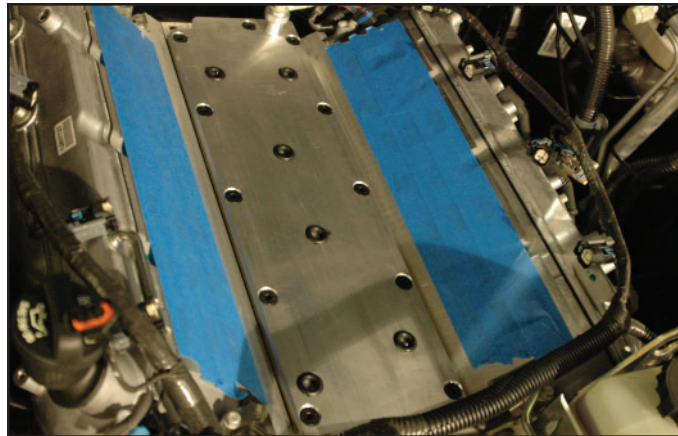

70. Replace the oil pressure sensor plug and locking clip on the oil pressure sensor.



71. Using a medium flathead screwdriver, pry up on the radiator release tabs. They will slide up easily until they hit a "stop".



72. This stop is accessed from the front side of the release tab, and using a small flathead screwdriver you depress the stop allowing you to pull the radiator mount lock free from the upper radiator mount.

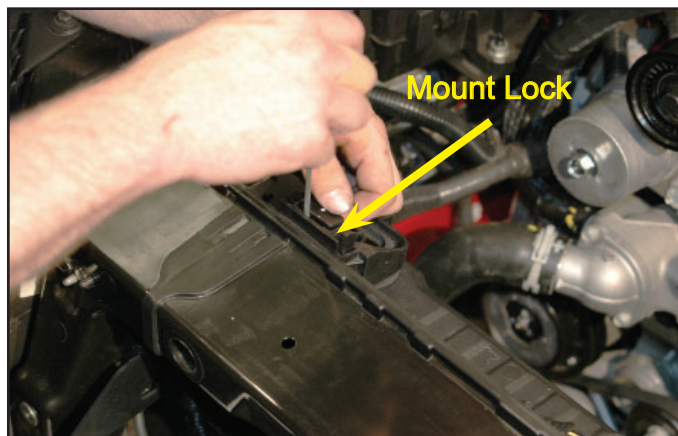

73. This picture is a closeup of the locking tab that needs to be depressed to allow the mount lock to be removed.

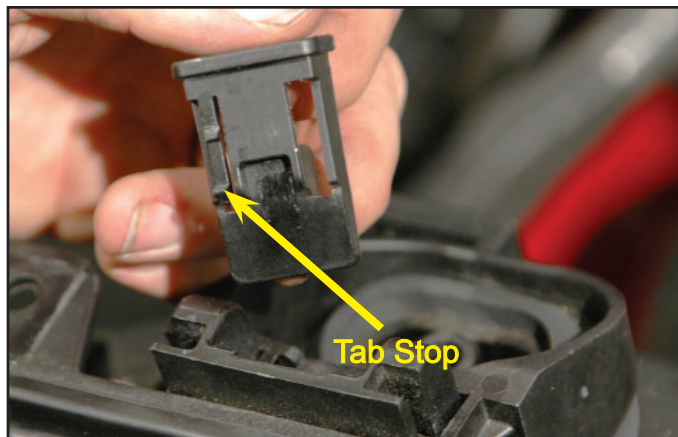

74. From inside the slot where the lock tab was removed, use the small flathead screwdriver to lever the final locking tab inward, allowing the upper radiator mount to be pulled up and free of the frame.

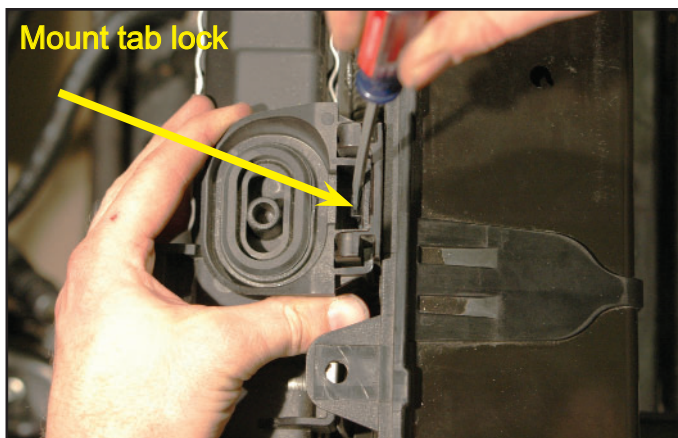

75. This picture shows the mount lock being removed. Repeat on other upper radiator mount. The radiator can now be pivoted backward toward the engine block for heat exchanger installation.

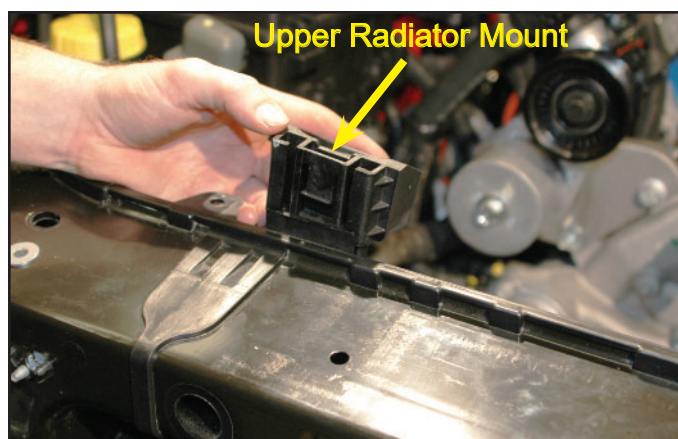

76. Remove the rubber seal from the top of the A/C Condenser. This will get modified and re-installed in a later step.

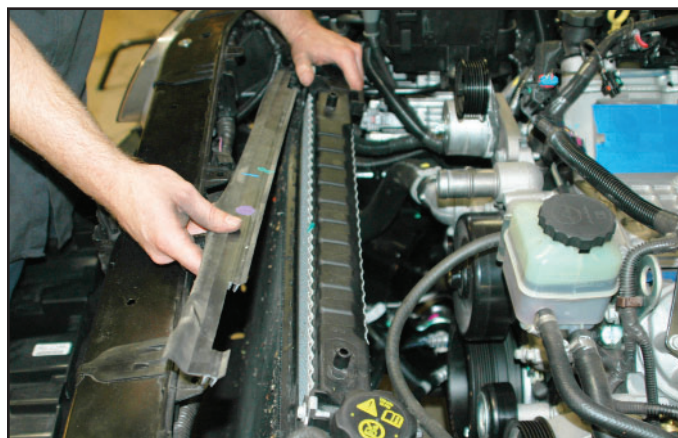

77. As an option, you can rattle-can the provided Intercooler Heat Exchanger black to minimize the visibility through the grille.

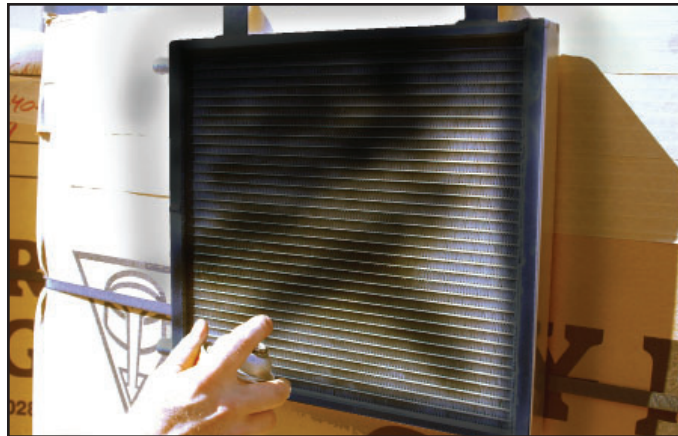

78. Using a 10mm socket, remove the three M6 transmission cooler bolts from the fascia frame mounting brackets.

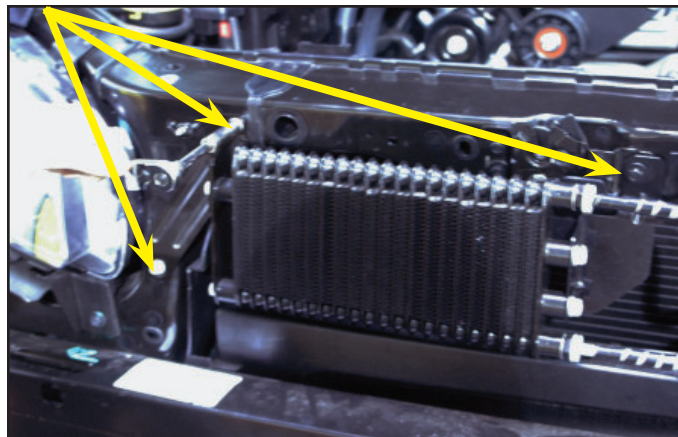

79. Apply the two ½" x 15" and the two 1" x 3" rubber strips to the Heat Exchanger as shown.

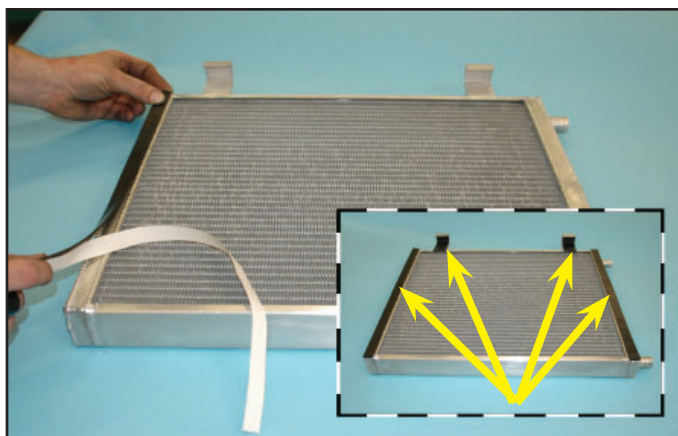

80. Pull back on the top of the radiator toward the engine, slide the Heat Exchanger down in front of the A/C Condenser, hooking the two top brackets onto the condenser. Locate the new Heat Exchanger so that there is 4-1/8" between the existing AC condenser mount to the existing radiator and the new "hook" shaped mounting bracket on the passenger side of the heat exchanger. Be sure not to pinch the small hose coming from the windshield wiper reservoir between the heat exchanger and condenser.

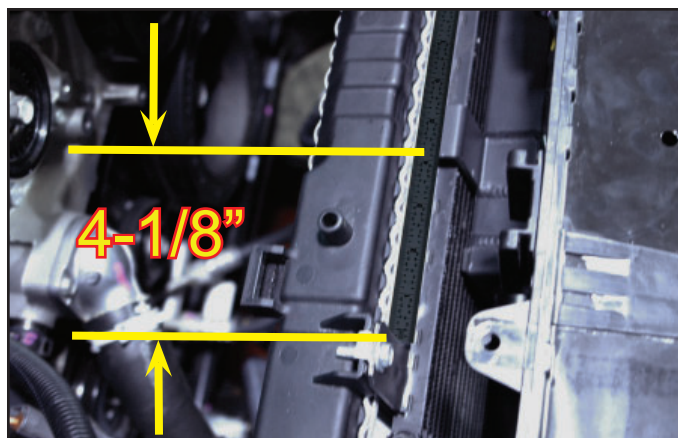

81. Next, trim the rubber seal in the two spots as shown. This will allow the seal to re-install around the Heat Exchanger brackets.

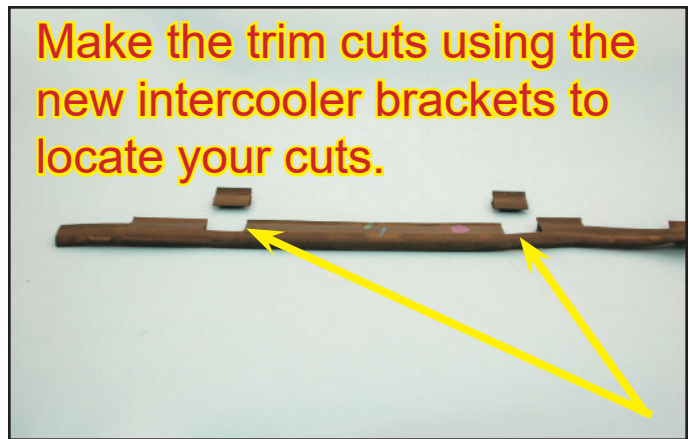

82. Now re-install the modified rubber seal onto the condenser. Refer to steps 71 thru 75 to reinstall the plastic upper radiator mounts to secure the radiator back in place; then reinstall the bracket locking tabs.

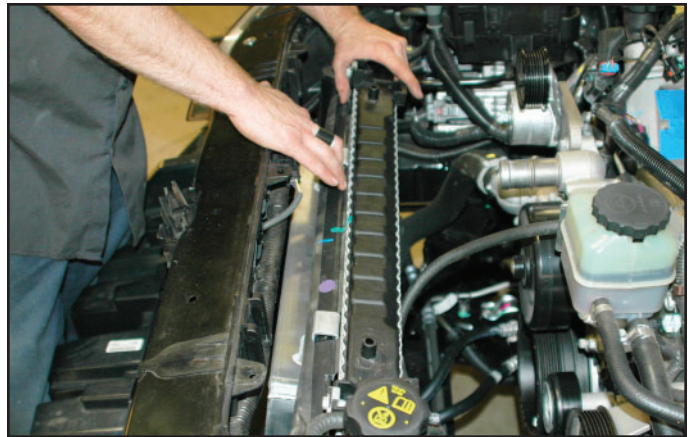

83. Cut a section of the 3/4" hose to 59" in length. Connect one end of the hose to the top barb of the just installed intercooler heat exchanger and clamp using the provided clamp. Run this hose down behind the frame and temporarily out the front of the radiator cowl at the bottom-passenger side.

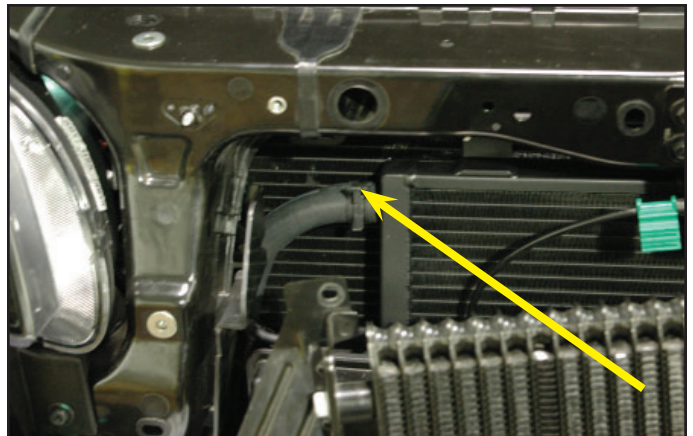

84. There are three provided transmission cooler offset brackets. Attach one to the upper passenger side bolt hole (place a provided washer between the bracket and frame for this hole) where the transmission cooler was originally mounted using the provided bolt. Attach one to the driver side bolt hole from where the transmission cooler was originally mounted.

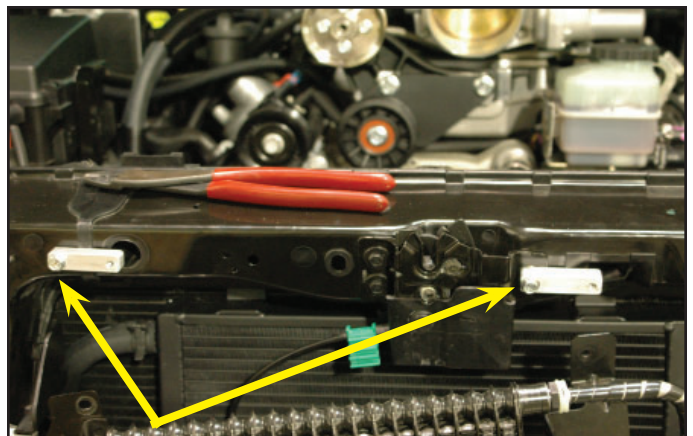

85. The passenger side plastic air deflector will need to be modified to mount the lower transmission heat exchanger offset bracket. Use dykes or cross cutters to cut a notch for the bracket. This will be at approximately 45 degrees from a horizontal plane.



86. Attach the remaining heat exchanger offset bracket to the existing bolt hole where the transmission cooler was originally mounted.

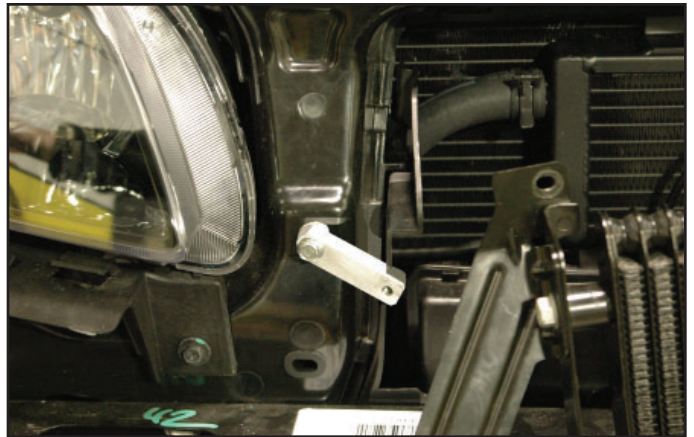

87. Completely remove the existing transmission cooler mounting bracket from the driver side of the transmission cooler. Using a saw or grinder modify the bracket as shown. You're taking off approximately 5/8" from the tab with the upper mounting hole all the way down to the bend in the bracket.

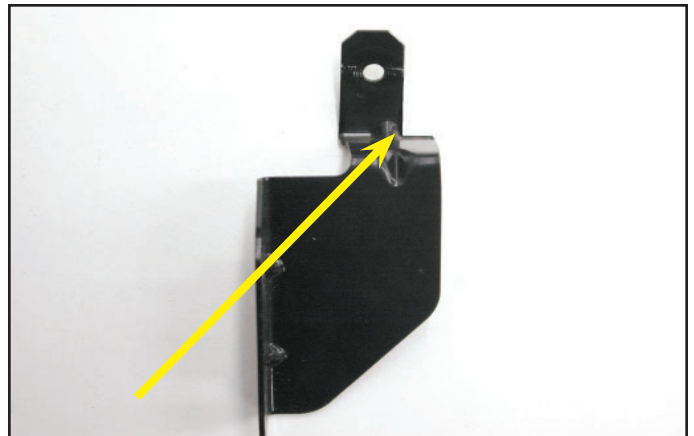

88. Attach the bracket back on the transmission cooler. Using the original bolts, bolt both mounting brackets to the just installed offset mounting brackets. Tighten all bolts using a 10mm socket being careful not to strip threads. **NOTE: Cooler lines may still require a little bending to clear the heat exchanger and any other interference areas.**

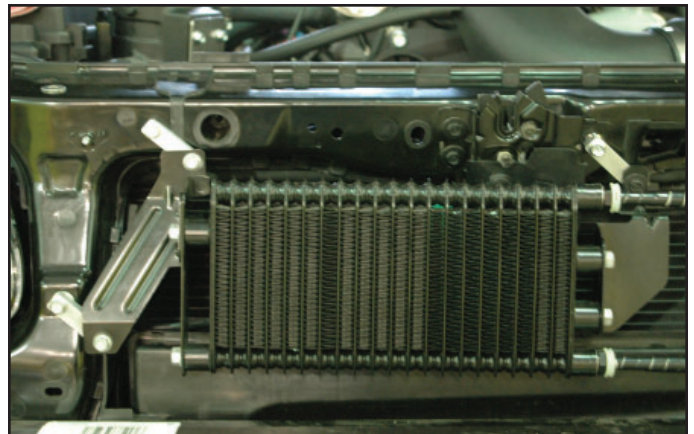

89. Reinstall the transmission cooler hardline on the driver side frame rail inserting the new provided spacer between the frame and the bracket using the provided bolt. Tighten using 10mm socket.

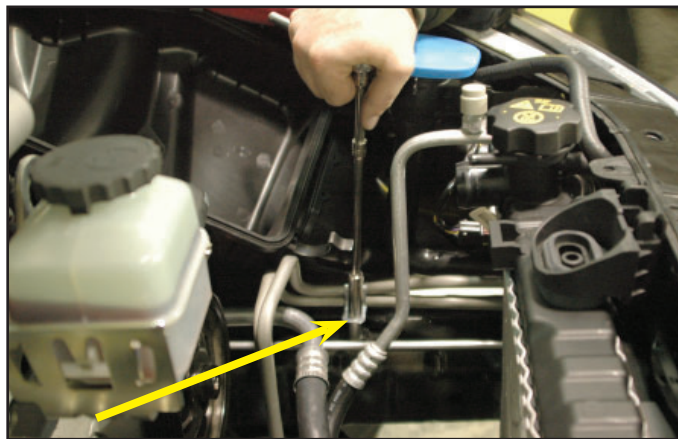

90. Reinstall the transmission cooler hardline on the crossover rail also inserting the new provided spacer between the frame and the bracket using the provided bolt. Tighten using a 10mm socket.



91. The following two steps are prep for later procedures. The Intercooler pump plate and bracket mount will now be located. Use the existing hole located just to the driver side of the lower cross-member as one hole. This existing hole is toward the center from the existing 5/8" diameter hole located in-line with the driver-side edge of the crank pulley. Mark the second hole using the mounting plate as a guide. Use the supplied self tapping screws as your drill bit, drill and tap your hole.



92. Open and tap the existing hole also using the self tapping screw as shown. Set the self tapping screws aside for later mounting of the intercooler pump.



93. With the radiator mounted back in its stock location, you can now re-install the electric fan assembly.



94. Plug the electrical connection back into the fan assembly.

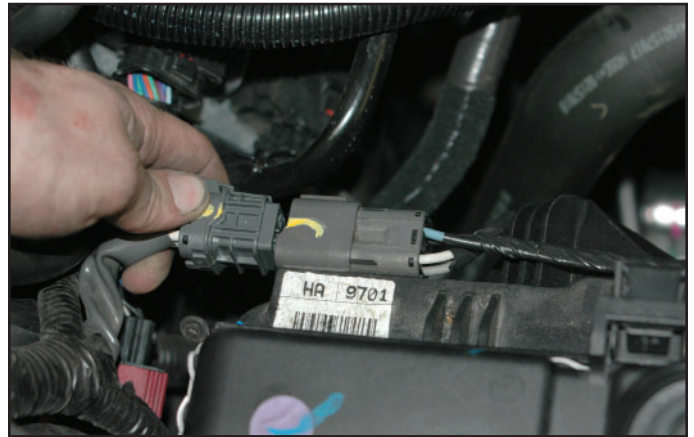

95. Press the two transmission cooler lines back into the retainer clips on the fan assembly.



96. You can now re-connect the coolant overflow hose back to the hose barb on the radiator neck.



97. Now re-install the upper radiator hose and secure in place with the stock clamps. The coolant overflows can now be relocated to the stock locations and clips on the radiator fan shroud.

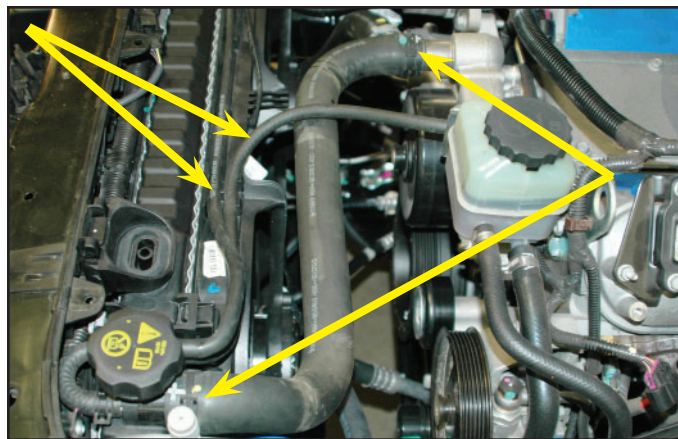

98. Locate the ETC connector on the engine harness. This will need to be extended with the supplied extension harness.

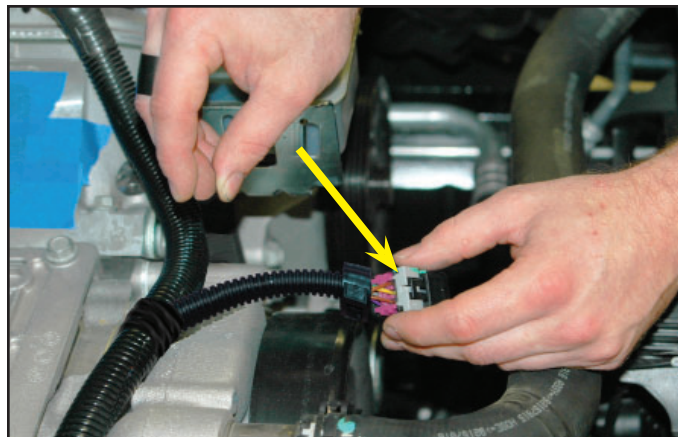

99. This is the provided ETC connector extension harness.



100. Plug the extension into the existing ETC connector, route the wires adjacent to the existing wiring harness to the driver side of the engine.



101. Disconnect the main coil connector from the coil rail.

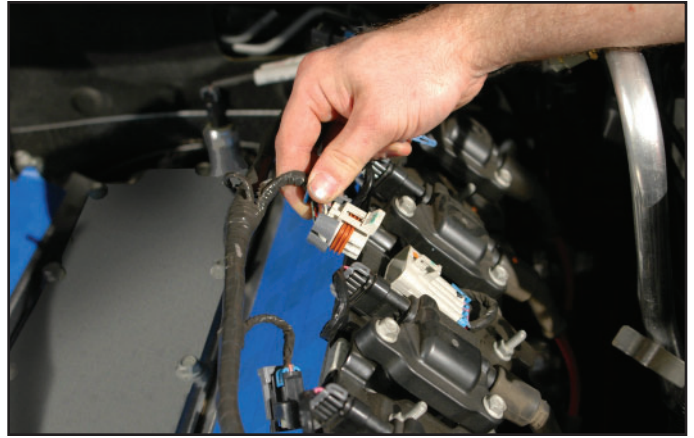

102. Disconnect all plug wires from the coils.

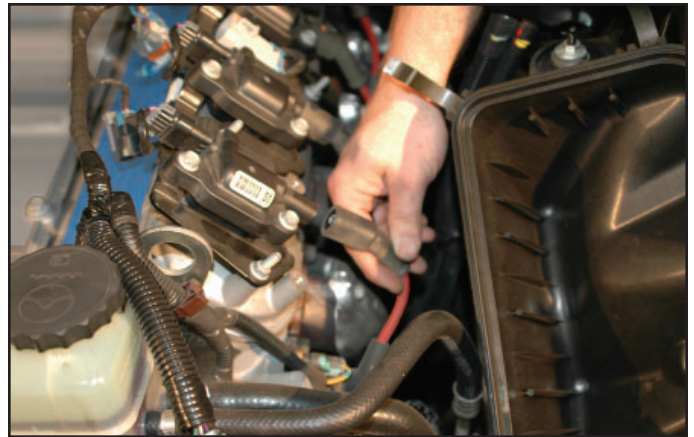

103. Remove five 10mm bolts from the coil brackets on each side, and remove the coil brackets from the engine to be modified below.



104. Remove the plastic wire loom covers from the coil bracket assemblies. Do this procedure on both sets of coils.



105. Trim the plastic cowl at the center of the run as shown and described. From the center seam, trim off 4-1/4" on the driver side. From the center seam, trim off 3" on the passenger side.

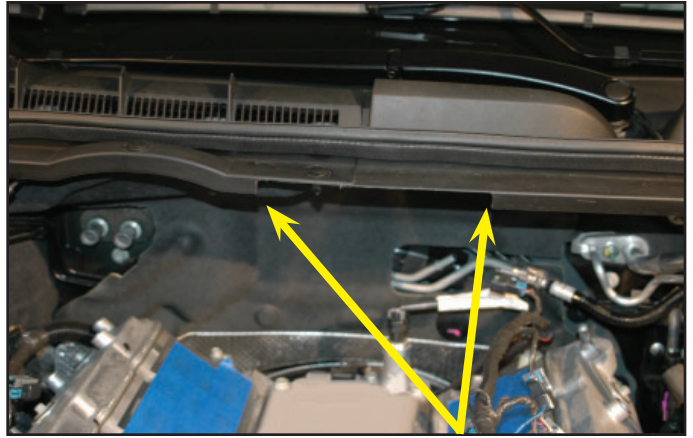

106. The power steering reservoir mount will need to be spaced-outward to maintain clearance with the new throttle body location. Remove the power steering reservoir by levering out on the metal locking tab, then slide the bottle to remove.



107. Remove the two stock reservoir bracket mounting bolts using a 15mm socket.



108. Mark the bracket as shown in the picture. On the edge closest to the passenger side bolt, make a mark adjacent to the bolt witness mark. The material to the outside of your mark will have to be removed.

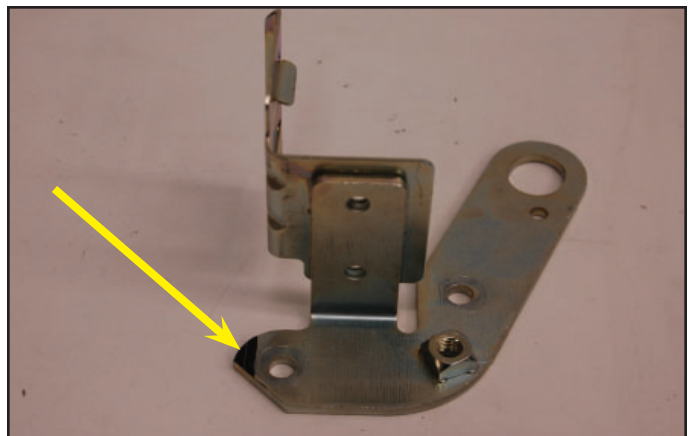

109. Use a grinder or suitable file to remove the material. Your final result should look like this. Dress the edges to avoid sharp surfaces.

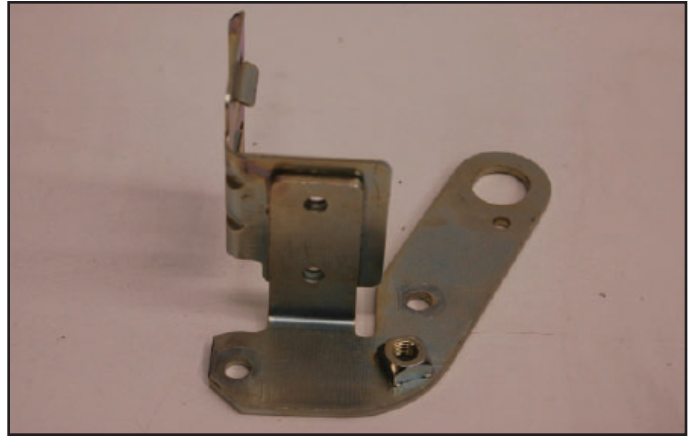

110. Place the provided bolts through the holes of the bracket, insert the provided spacers and bolt the bracket back onto the engine. Torque the bolts to 35-40 ft-lbs. Verify your torque wrench settings.



111. Remove the MAP sensor from the stock intake manifold.

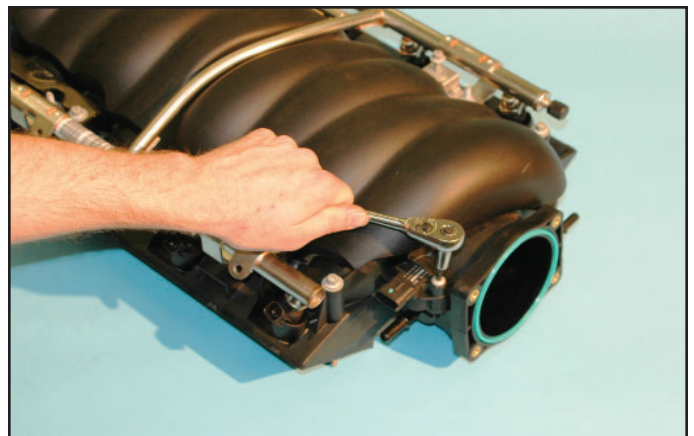

112. Use a 10mm socket wrench to unbolt the stock Fuel Rails from the stock intake manifold.

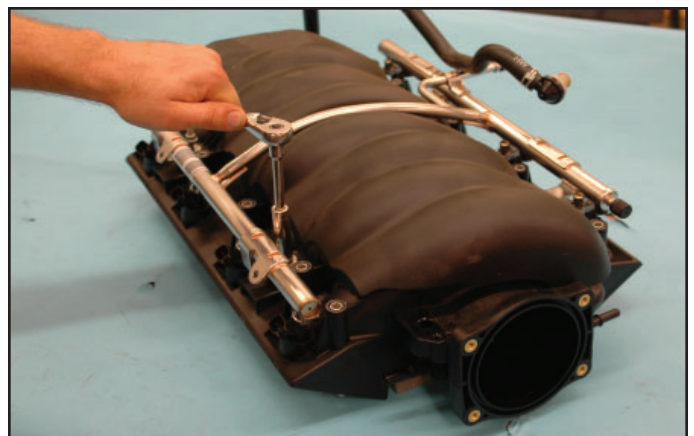

113. Unsnap and remove the clips holding the fuel injectors to the stock fuel rails, and remove the injectors. **Note: There will be fuel leakage from the injectors and fuel inside the fuel rails. Take care to have an appropriate catch pan and shop rags handy, then dispose of the fuel collected and any rags used properly.**



114. Use a 10mm socket wrench to remove the fuel rail bolts connecting the supplied fuel rails to the new intake manifold. You may leave the fuel lines (front and back) attached. Lift the rails up to allow the injectors to be installed. Use the supplied Lubriplate lubricant to lube the O-rings of the stock injectors and insert the eight stock injectors into the new manifold below the fuel rails. Point the electrical connections outward.

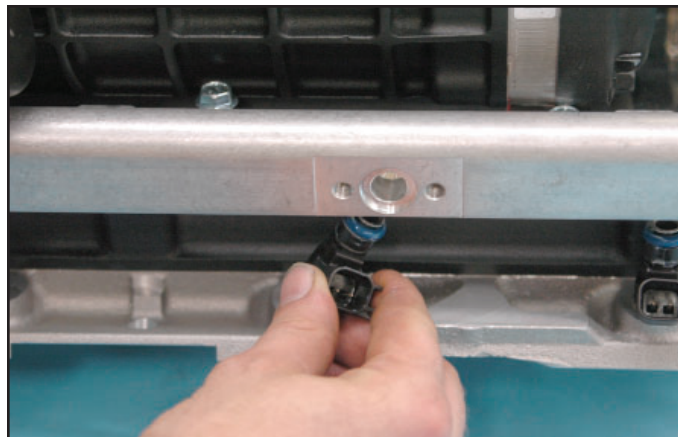

115. Lubricate the upper O-rings of the stock injectors, align and carefully press the fuel rails down onto the installed injectors.

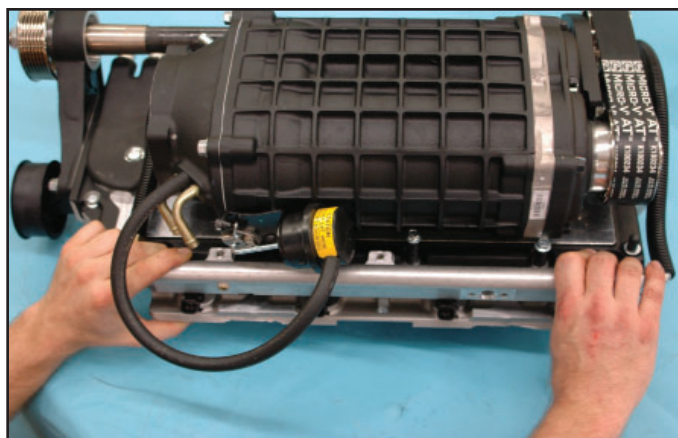

116. Reinstall the fuel rail bolts and torque to 106 in-lbs. Verify your torque wrench is correctly set to inch-pounds.

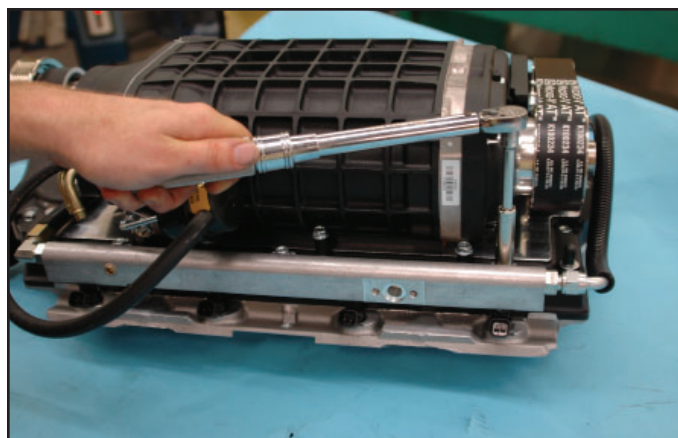

117. Remove the O-ring from the stock throttle body connector groove.

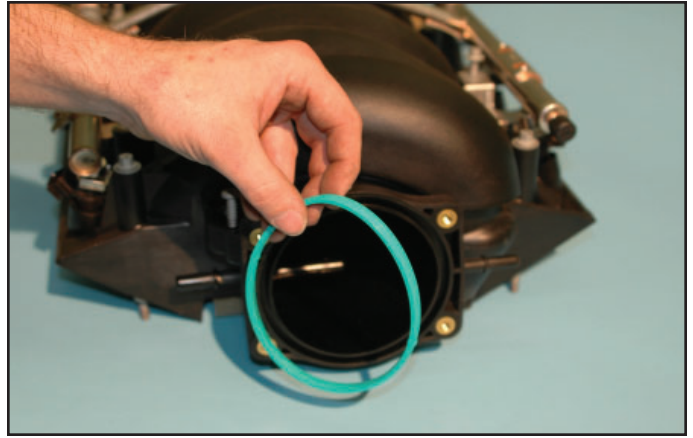

118. Install the MAP sensor on the new Supercharger assembly.

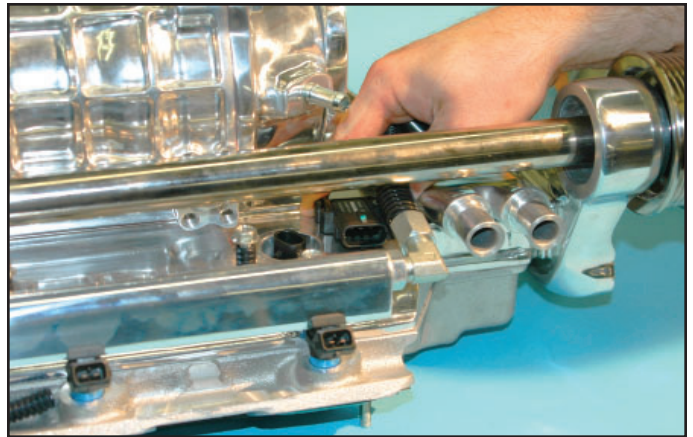

119. Snap the supplied intake manifold gaskets onto the new Supercharger intake manifold.

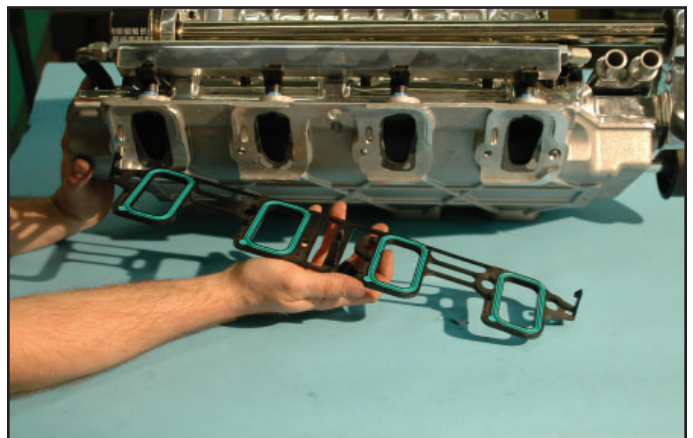

120. Install the stock O-ring for the throttle body into the groove on the Supercharger assembly.

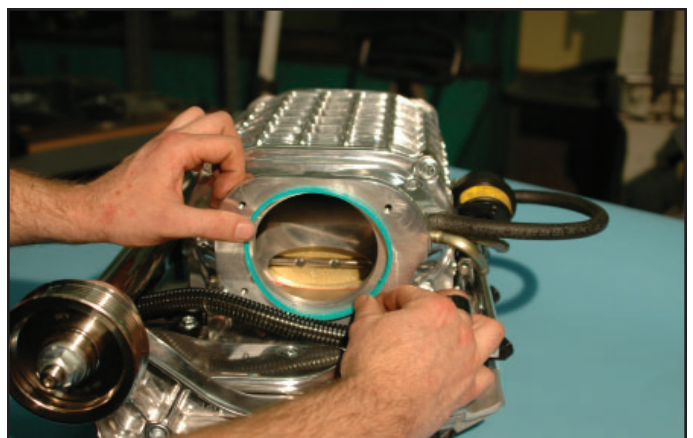

121. Install the Throttle Body on the supercharger using a 10mm socket wrench, torque the bolts to 106 in-lbs. Make sure you are using the correct settings for your torque wrench.

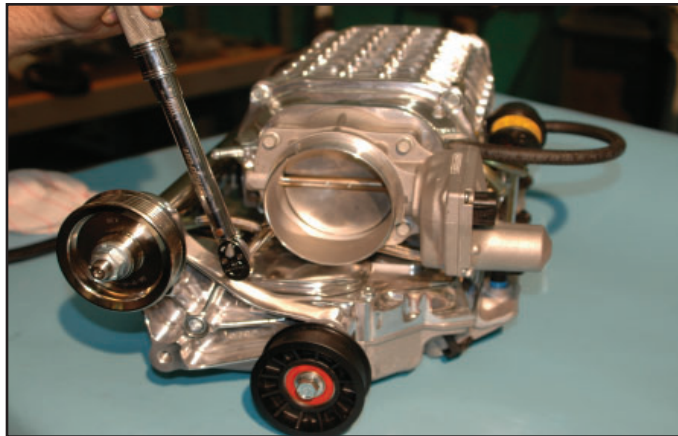

122. Using the supplied Lubriplate lubricant, lube the O-ring and insert it into the groove on the driver side fuel rail.



123. Install the fuel supply manifold on the fuel rail, and torque the 106 in-lbs. Verify your torque wrench settings.

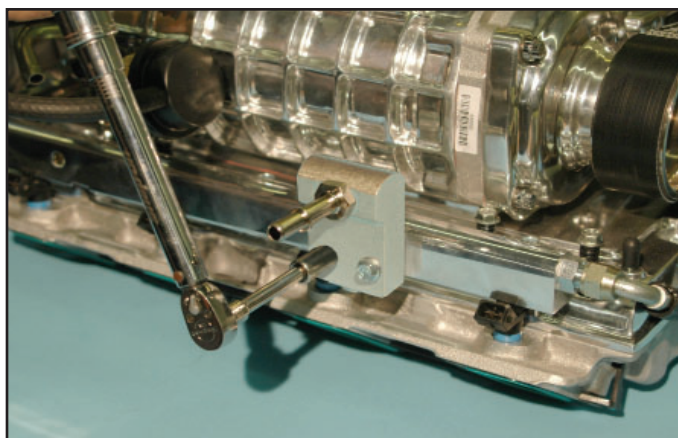

124. Remove the tape from the heads and lubricate with silicone spray (non petroleum base lubricant). Get another pair of hands to help, and carefully lift the supercharger assembly into the engine.



125. Remove the split loom spacers from the intake manifold bolts so that the bolts can drop down to engage the threads on the heads.



126. After an initial hand tightening, torque the bolts down to 106 in-lbs. Make sure you check your torque wrench settings. Rear passenger side bolt is difficult with a torque wrench, you may have to use an open-end wrench to reach this bolt or preferably an open-end crows-foot wrench to connect to your torque wrench. To allow more clearance in the work environment, you may want to remove the driver-side fuel rail.



127. Slide the power steering reservoir back onto the relocated mounting bracket, guide the tongue of the reservoir into the receiving angles of the bracket.



128. Use a flat blade screwdriver to push on and re-engage the metal locking tab of the bracket over the lip of the reservoir bottle.



129. Plug in the MAP sensor electrical connector.



130. Plug the fuel injector plugs to the injectors on each side of the engine. Make sure to route and stuff the wiring to avoid moving components.



131. Re-attach the modified coil brackets to each side of the engine using the stock hardware. **Do NOT install the second bolt back on the passenger side at this time.** Torque all remaining bolts to 106 in-lbs. Again, verify your torque wrench settings. Reattach the main coil connector at this time (removed in step 101).



132. Plug in the Throttle Body connector.

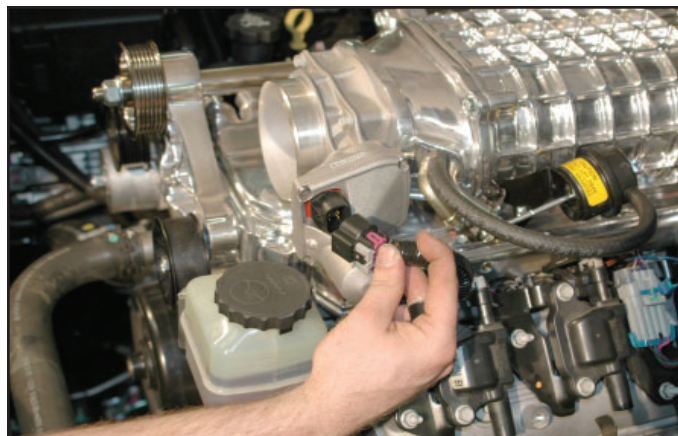

133. Attach the stock plug connectors back on to the coils on the coil brackets.

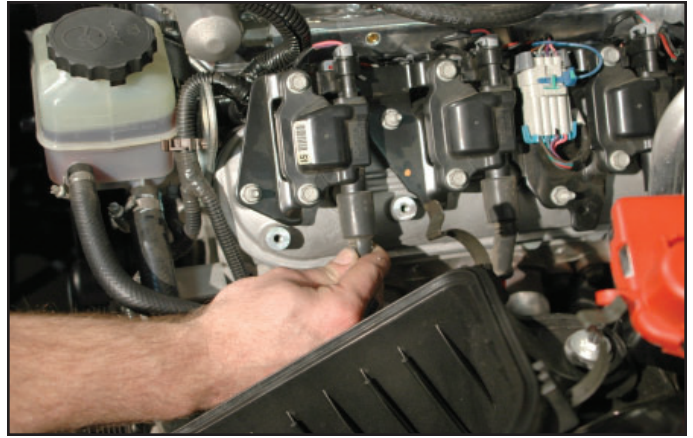

134. Attach the fuel line to the fuel manifold on the driver side of the supercharger. Be sure to attach the safety clip as well. Verify that you have a good connection. You should NOT be able to remove the fuel line without using the fuel line removal tool.



135. Cut two sections of the supplied 5/8" hose. One @ 34" and one @ 35". You will reuse the four stock clamps from the removed heater hoses. The 34" hose goes to the passenger side hose barb on the firewall, and the near hose barb on the water pump. The 35" hose goes to the center most hose barb on the firewall and goes to the front hose barb on the water pump. This is a 3/4" barb. So, lubricate the end of the 5/8" hose to facilitate installation. Slide the hose clamps into position using pliers, or hose clamp pliers on both the firewall and water pump ends.

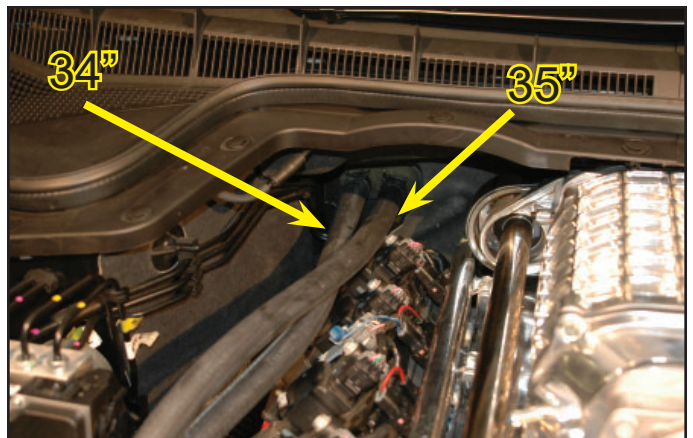

136. Using the supplied 6 x 45mm bolts, 1" spacer, and double hose clamp, install the clamp with the mount hole facing down over the just installed two heater hoses. Slide the bolt through the clamp, and put the spacer on the bottom of the bolt. Install the bolt into the second hole of the coil bracket on the passenger side (the one left out in step 131). Torque bolt to 106 in-lbs.



137. Loosely add zip ties to hold the hoses together, and add strips of split loom to prevent chafing on the fuse box.

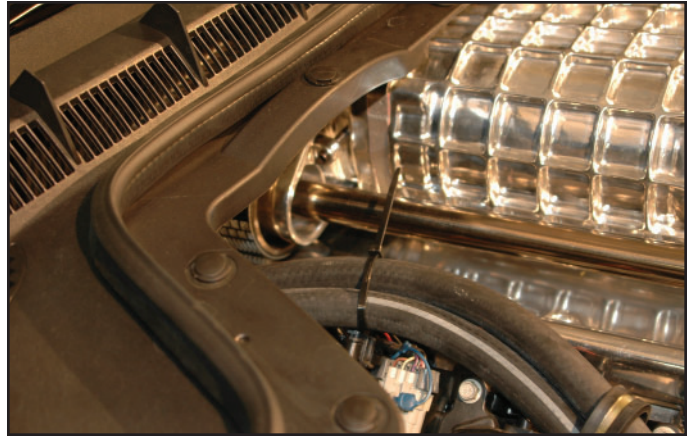

138. Plug in the EVAP sensor electrical connection.

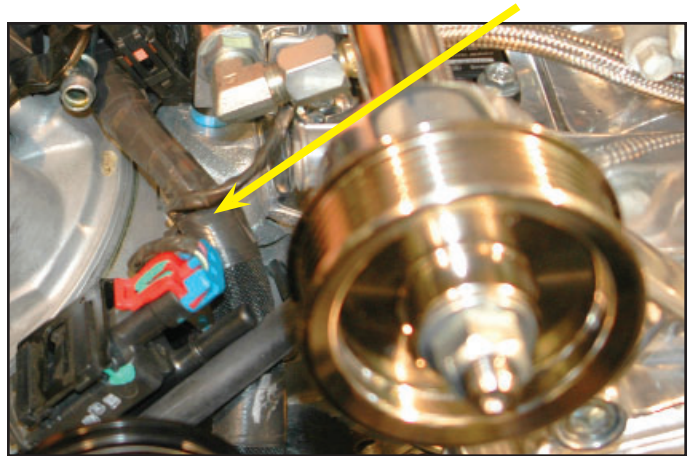

139. Use a sharp blade and split the ends of the EVAP lines and remove the three fittings.



140. Cut a piece of the supplied 5/16" hose to 40" long and install the right angle fitting removed in the prior step. No clamp is necessary.



141. Thread the open end of the 40" (5/16") hose under the front of the supercharger assembly, below the throttle body, and back along the coil bracket. Connect the right angle end to the EVAP solenoid as shown.

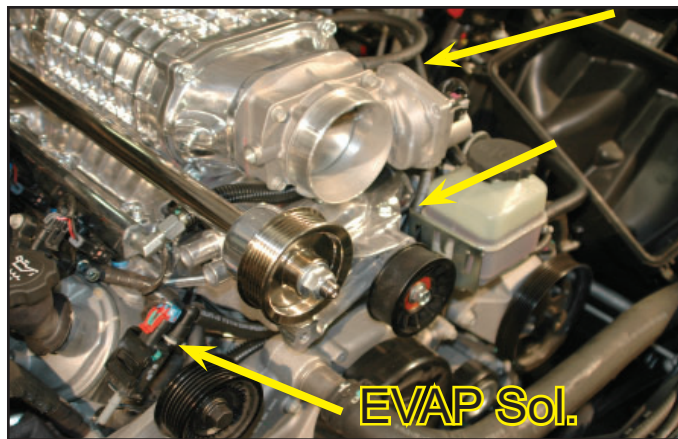

142. Insert one of the fittings removed in step 139 into the open end of the 40" hose and attach the fitting to the firewall connection as shown.



143. Cut 20" of the supplied 5/16" hose and install the remaining end (removed in step 139) onto the EVAP Solenoid as shown.



144. The other end of this hose connects to the supercharger hose barb as shown. Add zip tie at the heater hoses near the oil fill cap.

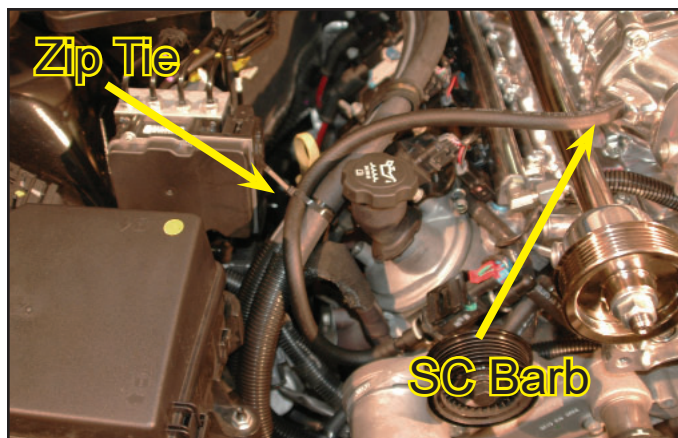

145. Cut 20" of the 3/8" hose, install on the PCV valve barb at the rear on the driver side-rear valve cover as shown.



146. Connect the other end to the front of the supercharger barbs on the driver side as shown.



147. Cut 20" of 11/32" brake hose supplied; attach the stock check valve on one end.



148. Install check valve at the brake booster as shown.



149. The other end of this hose connects to the vacuum barb on the supercharger inlet as shown.



150. Add zip ties to anchor the vacuum hoses as shown.

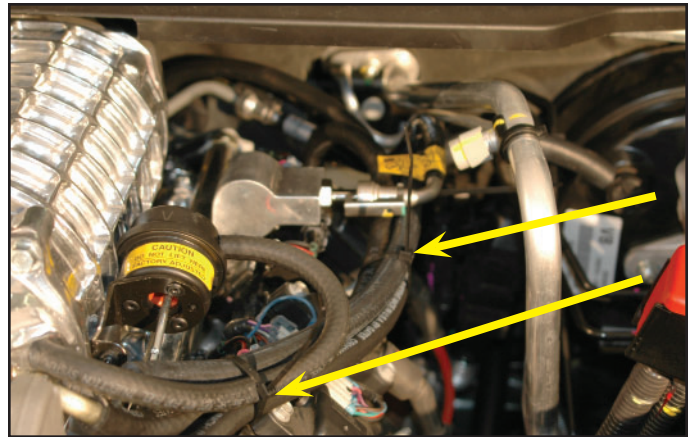

151. Cut a 16" section of the supplied 3/8" hose. Connect one end to the hose barb on the passenger side, front-above valve cover. The other end will connect to the inlet tube to be installed later.

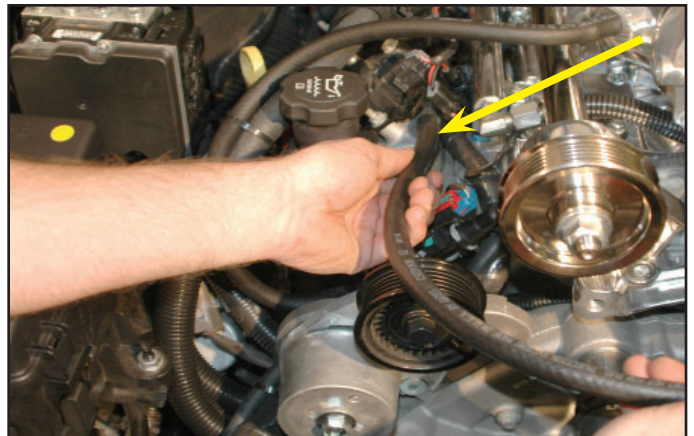

152. Near the front on the passenger side of the supercharger are the two IAT wires exiting the intercooler lid. Attach wire splice connectors to these IAT plug wire ends as shown in the first image. Route the wires from passenger side under the supercharger inlet.

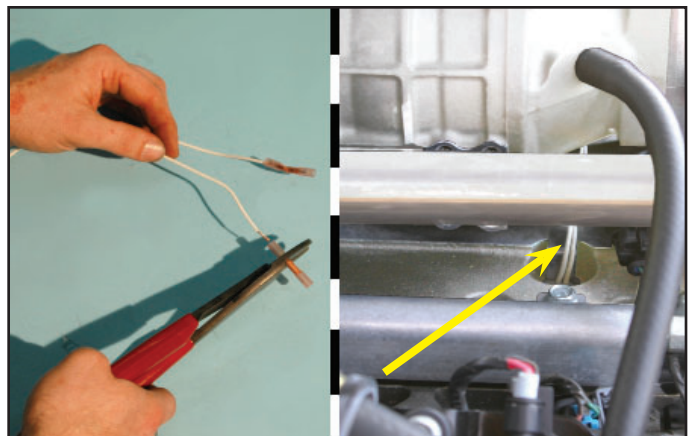

153. Uncover the wire loom to the MAF connector that hooks to the air box. Cut the brown with-white stripe, and the brown with-red stripe about 2" from the connector. The wire ends at the connector are abandoned and can be taped off should you wish.



154. Crimp the wires you just cut from the MAF connector, to the IAT sensor wires you routed under the supercharger inlet in step 159. The selection of the wire to connect to either terminal is of no consequence.

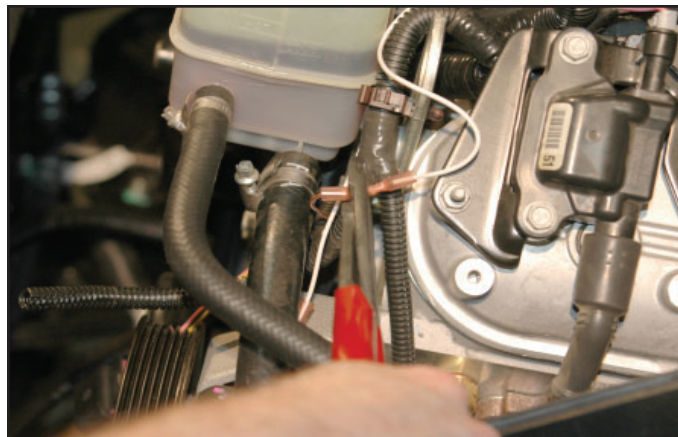

155. Heat shrink your connections to avoid moisture contamination and ensure a good connection.

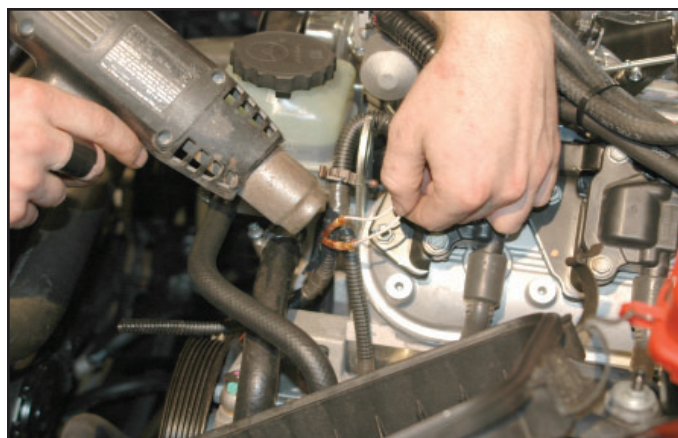

156. Re-place the split loom to the MAF plug. Cut a piece of split loom (supplied) to cover the new wires under the supercharger inlet (approximately 19") to the IAT sensor wire ends.

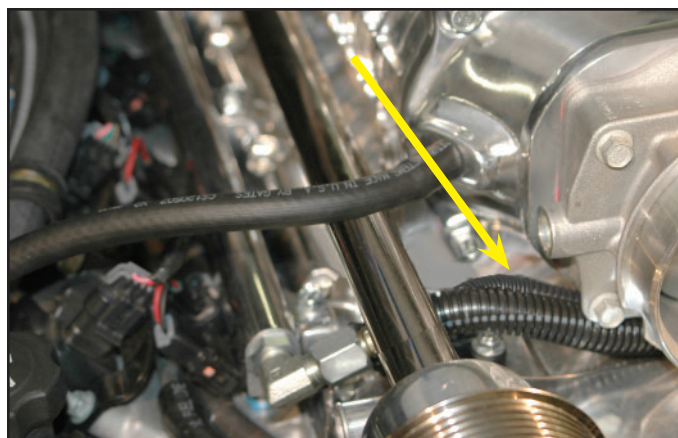

157. Ensure that the wire loom does not contact the jack-shaft and that the wires are covered completely.

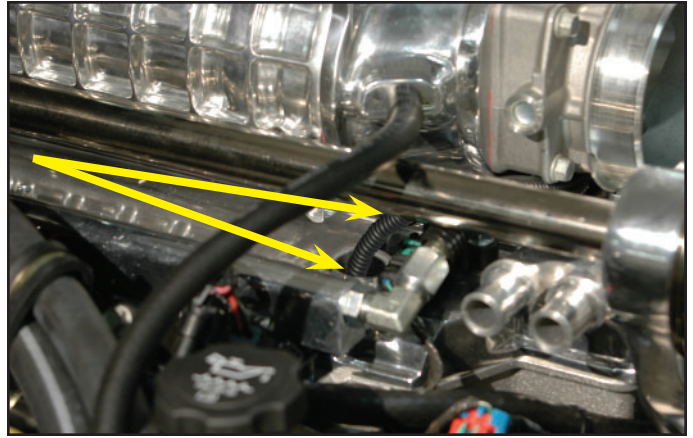

158. This procedure is easier using a helper, without a helper try to use your longest handle wrench for the tensioner. Route and install the supplied drive belt as shown in the drive belt diagram. You won't be able to get it over all the pulleys yet. Use a 15mm long wrench to lever the tensioner and utilize all pulleys. With the tensioner held compressed, push the idler firmly toward the tensioner pulley. Tighten the idler pulley bolt in this position. Now release the lever on the Idler tensioner allowing the belt to be put under proper tension. It's a good idea to go through this process again after the vehicle is first driven to adjust for stretching.

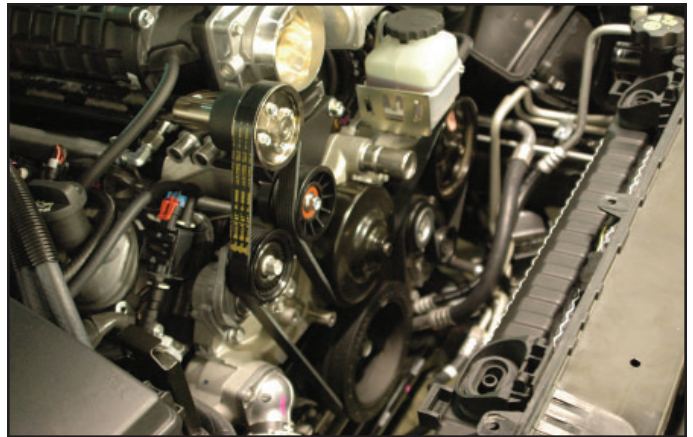

159. Install the air box filter and cover, snapping the retaining clips into position.



160. Plug the MAF connector into the MAF sensor on the air-box as shown.



161. Assemble the Intercooler Pump and bracket mount.

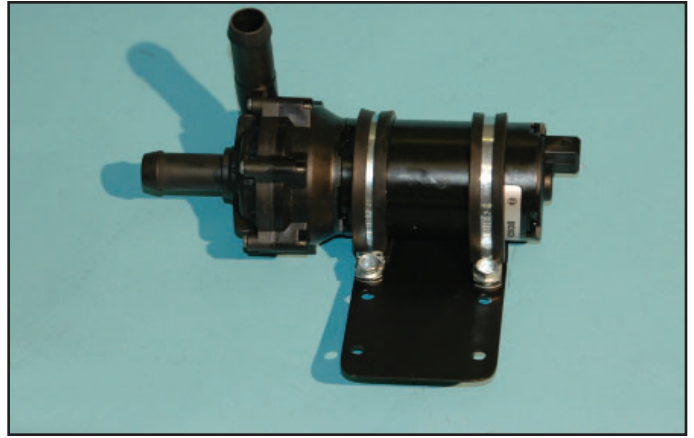

162. Mount the assembly using the holes you prepped in step 91. Be careful to not strip the self tap screw threads. Do not over tighten!

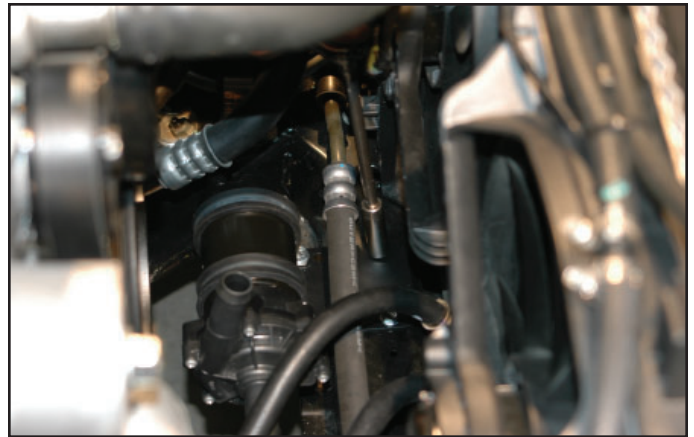

163. To mount the intercooler reservoir you will use the fuse box mounting bracket and need to modify the existing accessory bracket. Remove the nut with a 13mm socket.



164. This is the intercooler reservoir mounting bracket. The bottom hole mounts to the bolt post for the fuse box where you just removed the nut. From a straight out mount it will need to rotate approximately 30 degrees clockwise. As such the bracket will hit the accessory bracket. Mark the bracket as shown by scribing an estimated notch to be removed.

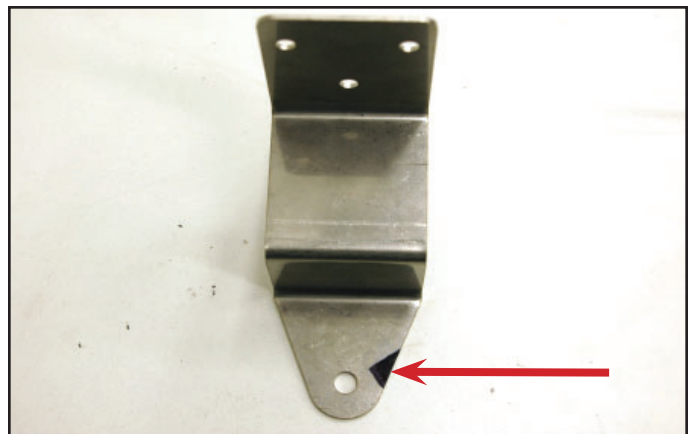

165. Test your fit and adjust as necessary. This is the modified-notched intercooler reservoir bracket, we curved the edges to eliminate any sharp surfaces.

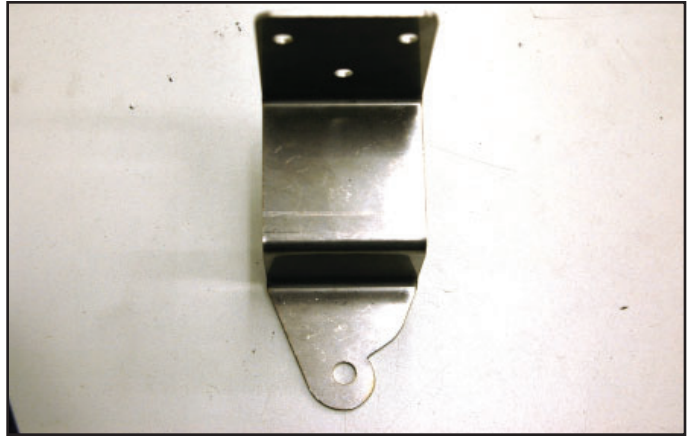

166. The top section of the existing accessory bracket will rub against the reservoir bottle and must be modified as well. From the outside forward edge, scribe a line back to the rear bend angle. This section will need to be removed. Use a cutting wheel, saw or suitable file to take this section out. Make sure you also dress the surfaces to eliminate any sharp edges.



167. Install the Intercooler bracket mount as shown onto the post using the nut you removed in step 163, tighten using a 13mm socket.

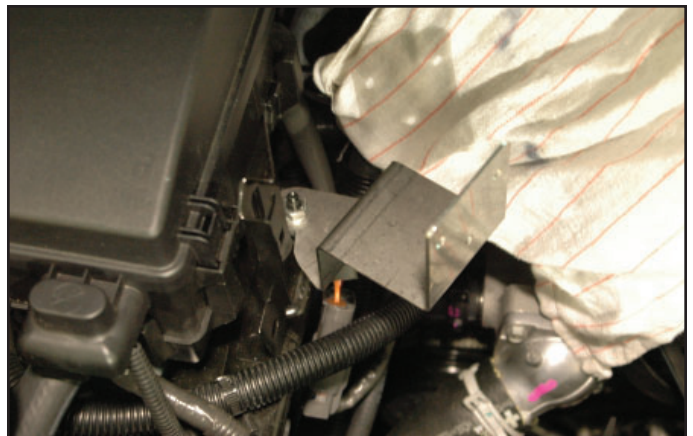

168. Attach reservoir to the mounting bracket with the three supplied bolts. Ensure that there is no reservoir bottle to existing bracket contact.



169. At the front-bottom-passenger side of the plastic radiator cowl, drill two 1-1/4" holes through the plastic cowl for the heat exchanger hoses as shown. Connect the holes by cutting the plastic between them, clean and dress the hole to remove sharp edges.

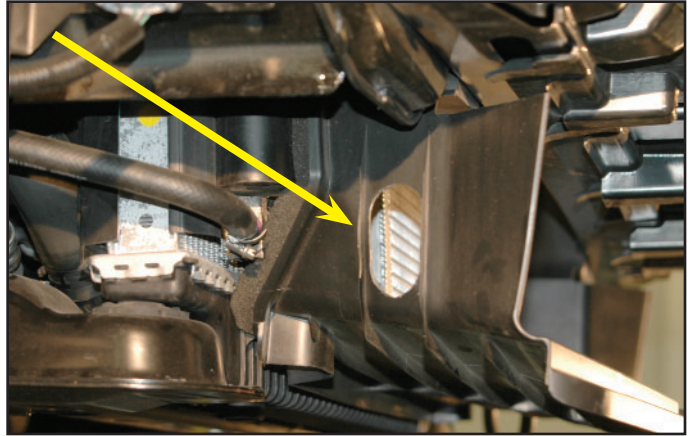

170. Cut a 46" section of the supplied 3/4" hose and connect one end to the lower heat exchanger barb using the provided clamp. Route the hose through the holes, up over the lower radiator hose.

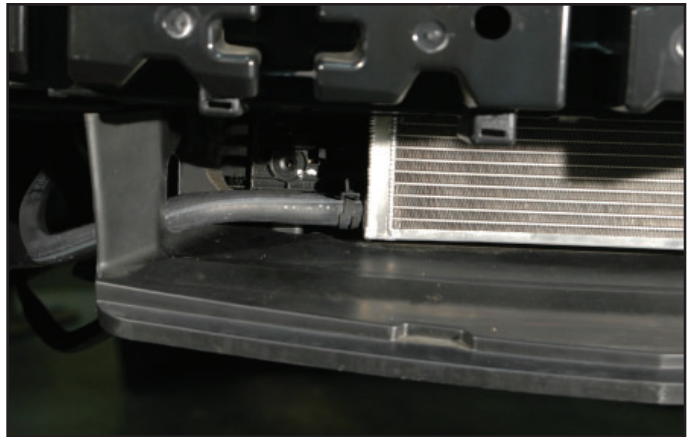

171. Connect the free end of the hose from the last step to the Intercooler pump discharge barb using the provided clamp.

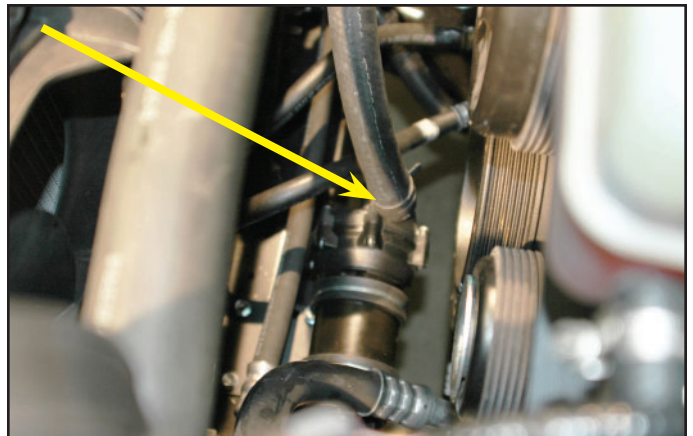

172. In step #83 you installed a 59" section of the supplied 3/4" hose to the upper heat exchanger barb using the provided clamp. Route the hose to follow the bottom heat exchanger hose through the hole in the cowl and into the engine compartment. This photo has the transmission cooler removed for clarity.

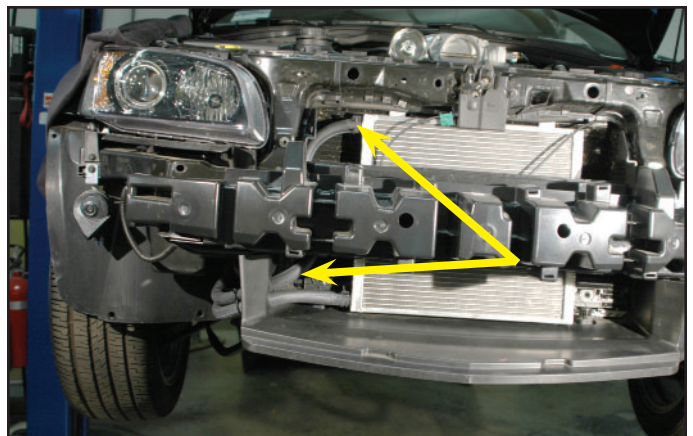

173. Clamp the free end of this hose onto the supercharger inlet barb using the provided clamp.



174. Cover hoses passing through plastic cowl with sections of the supplied split loom to avoid chafing and wear.

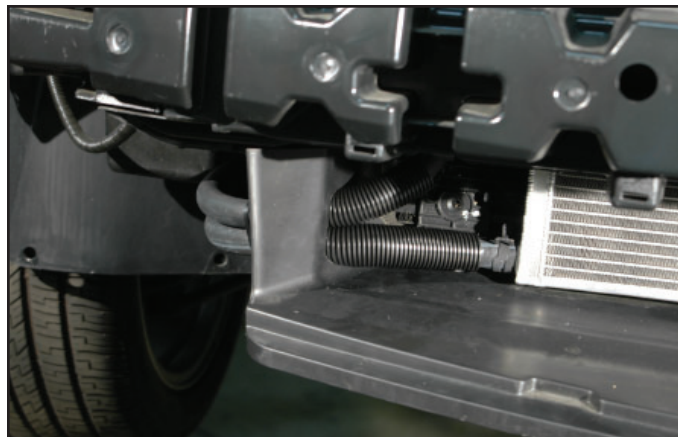

175. Cut 31" of the remaining 3/4" hose and connect one end to the water pump inlet barb using the supplied clamps.

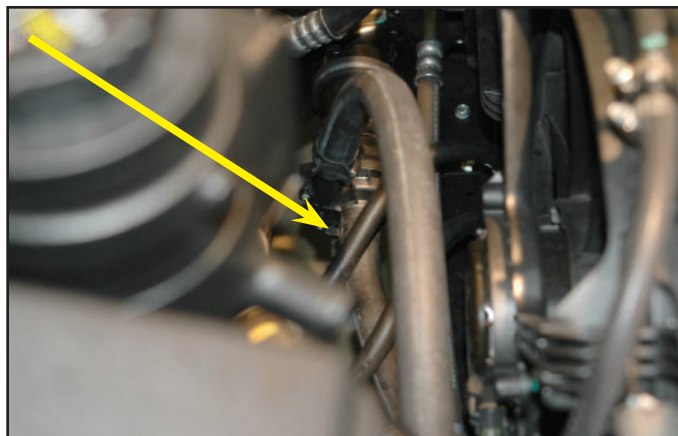

176. Route the hose to the intercooler reservoir and connect to the hose barb as shown using the supplied worm gear clamp.



177. Cut an 8" section of the 3/4" hose and connect between the intercooler reservoir and the supercharger hose barb as shown. Clamp with the supplied hose clamps. Make sure you use a supplied worm gear clamp on the reservoir.

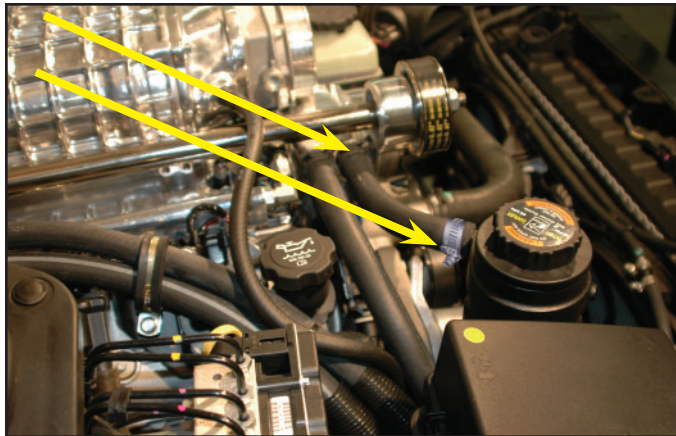

178. Use the supplied zip ties to anchor hose bundles, and sections of split loom to protect hoses from chafing edges.

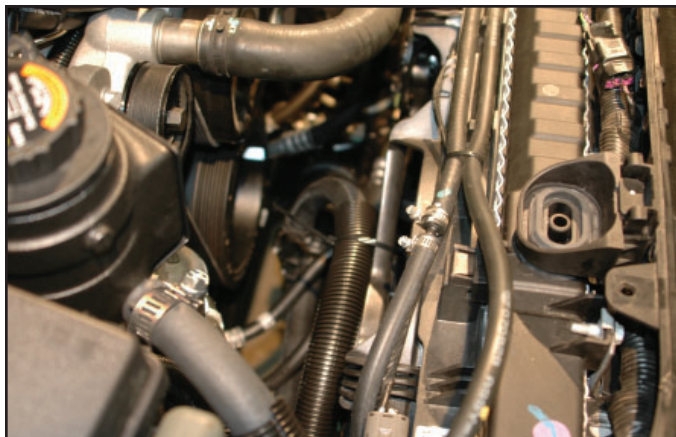

179. Remove the fuse box cover.



180. Remove the HVAC ignition fuse (slot F-37), verify the fuse by fuse name, in some instances the fuse may be in a different slot.



181. Slip the supplied fuse tap over one leg of the OEM 10Amp fuse from the last step.

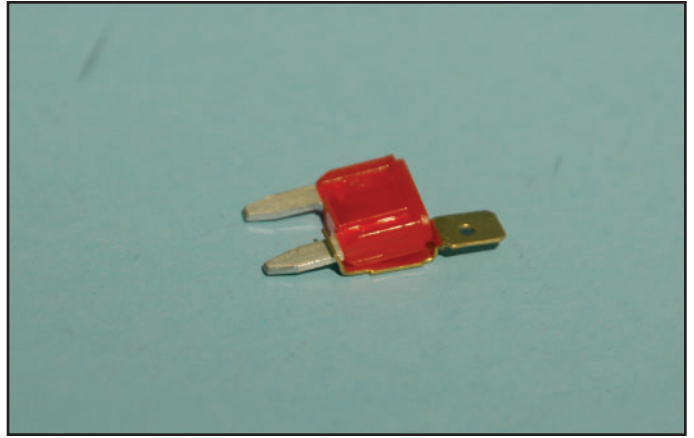

182. Insert fuse with fuse tap back into slot you removed it from, probably F-37.



183. Insert the supplied fuse into the supplied wire bundle.

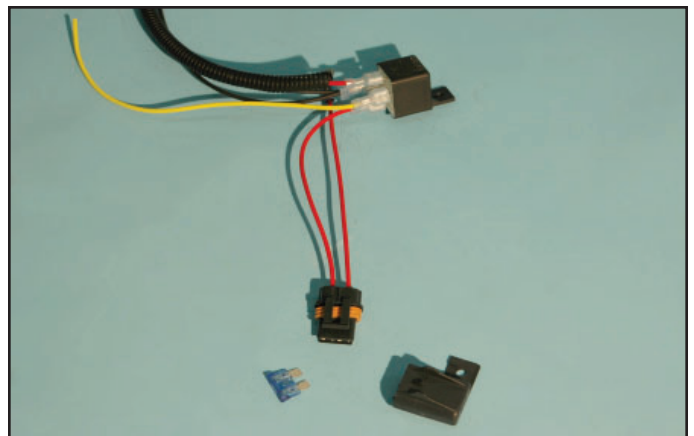

184. Zip tie intercooler relay to wire bundle adjacent to the coolant reservoir fill cap.



185. Route the intercooler control plug wires down along the hoses, zip tie as handy and plug into the intercooler pump receptacle.

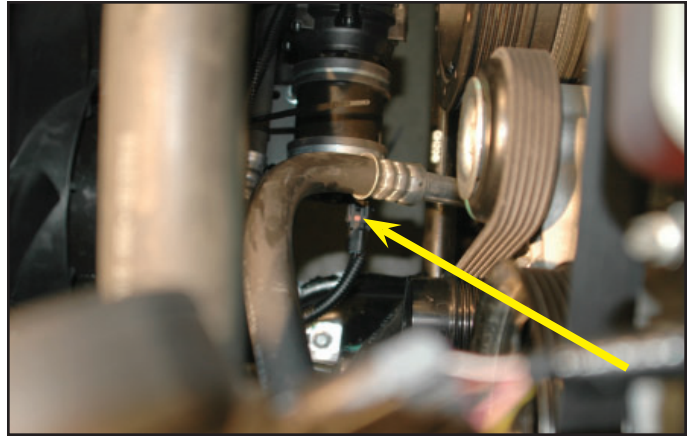

186. Shorten the black lead about 12" and attach the new eyelet end supplied.

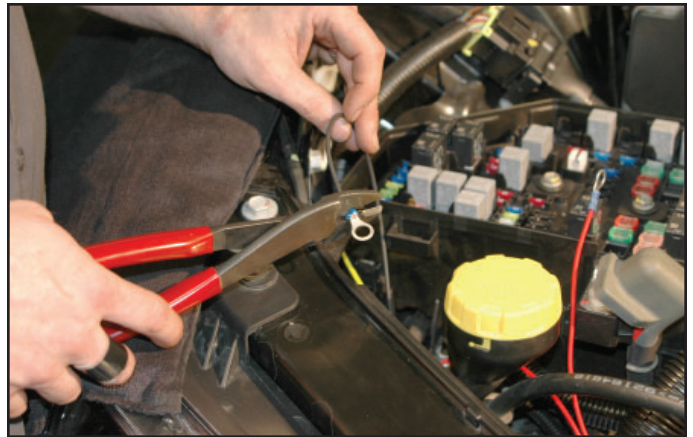

187. Use a 13mm wrench to remove the fuse mount bracket bolt. Re-attach the bolt incorporating and grounding the black lead wire.



188. Remove the hot lead nut from the front of the fuse box with a 13mm wrench. Add the new hot lead wire and replace the nut.



189. Drill a 1/8" diameter hole for the new intercooler pump wire to route to the fuse-with-fuse-tap, probably in slot F-37. Thread the yellow wire through the new hole, THEN attach the supplied connector.

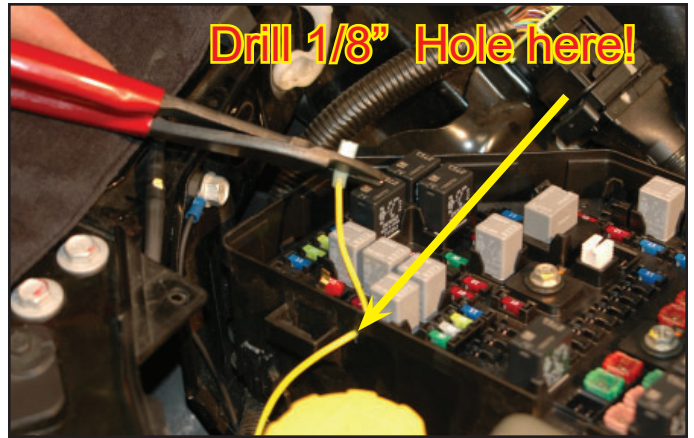

190. Plug the new yellow wire connector onto the fuse tap installed earlier, probably in slot F-37.

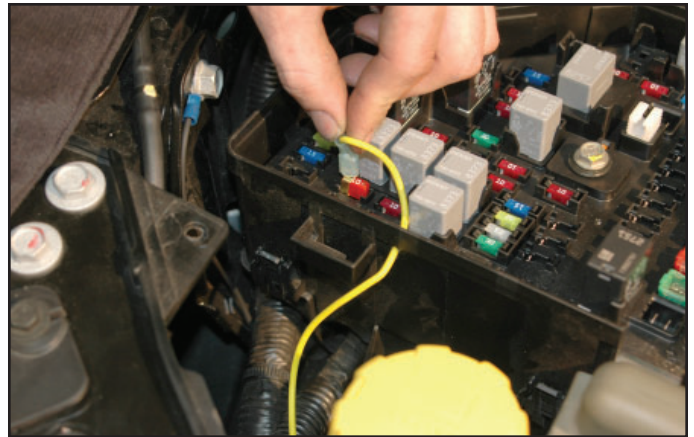

191. Replace the fuse box cover.



192. Remove the inlet coupling from the inlet air tube and install it on the throat of the throttle body.



193. Connect the air inlet tube to the air-box at the bellows end.



194. Connect the other end of the inlet tube to the supercharger inlet. Tighten all clamps.



195. Connect the other end of the hose installed in step 151 to the barb on the air tube near the throttle body.



196. Re-install the factory plastic “splash shield” using the stock four 13mm bolts and existing mounting holes. If you removed it (step 34) replace the 5mph plastic bumper by pressing it into place

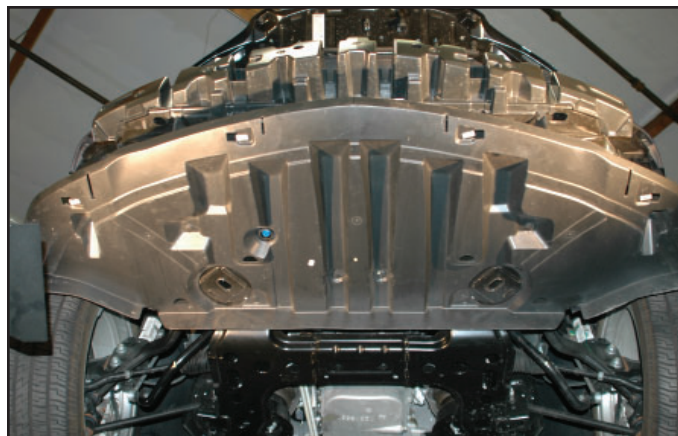

197. Re-install the front end fascia using the stock hardware (2-bolts, and 2-push pins) on the top surface.



198. In front of the passenger side wheel well, plug the lights back into the connector. This was disconnected in step 29.

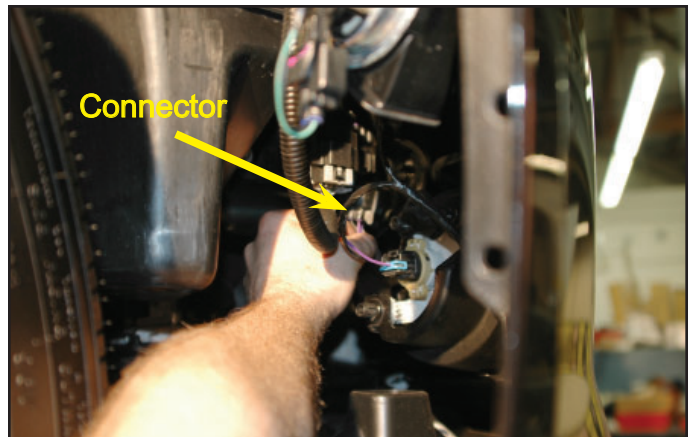

199. Bolt the fascia to the fender with the two connectors on each side and use the factory push-pins to attach at all points (4-each side). If you removed the fender well in step 27, then reattach at this time reversing the procedure.



200. Use the four 7mm bolts to bolt the fascia through the "splash shield".



201. Re-attach the battery lead cables, and replace the battery cover panel access door.



Make sure that you have followed step #1 in this manual to load the proper supercharger calibration to your vehicle's ECM.



202. Verify that your coolant drain is tightened and refill the coolant reservoir, topping off as necessary with a GM approved engine coolant mixture only.



203. Fill the intercooler reservoir with a GM approved engine coolant mixture only.



204. Attach the Vacuum Routing Diagram, Intercooler/Belt routing information and Premium Fuel stickers on the radiator shroud.



205. Start the vehicle for five seconds and shut off, once again check for fuel leaks and fan-supercharger belt alignment. Check radiator and intercooler reservoir levels.



206. Test-drive the vehicle for the first few miles under normal driving conditions (**Do not perform any wide open throttle runs**). Listen for any noises, vibrations, engine misfire or anything that does not seem normal. The supercharger does have a slight whining noise under boost conditions, which is normal.



207. Re-check the intercooler reservoir coolant level regularly over the first 1000 miles, top level off as needed.



208. After the initial test drive, go through the belt tensioner adjustment process (step # 165) again. When next you start driving, gradually work the vehicle to wide open throttle runs, listen for any engine detonation (pinging). If engine detonation is present let up on the throttle immediately. Most detonation causes are low octane gasoline still in the tank. **Premium gasoline fuel (91 octane or better) must be used! It is NOT compatible with E85.** Affix the Premium Fuel Only decal on the inside of the fuel fill door.

After you finish your installation and road test your vehicle, please fill out the warranty registration. This can be found on our website.



If you have questions about your vehicles performance, please check with your installation facility.

While the supercharger fits under the hood, there is a slight pressure on the hood liner. To alleviate this issue, the following modifications are necessary. Place a piece of tape between the center line of the forward grommets. Measure 2" from the step relief on the driver side and run a piece of tape back. Measure 4.5" from the passenger side step relief and run a piece of tape back. Measure back from the first piece of tape 4.5" and run a parallel piece of tape. Remove the area inside the tape lines using a sharp razor knife being careful to not damage the underside of your hood.

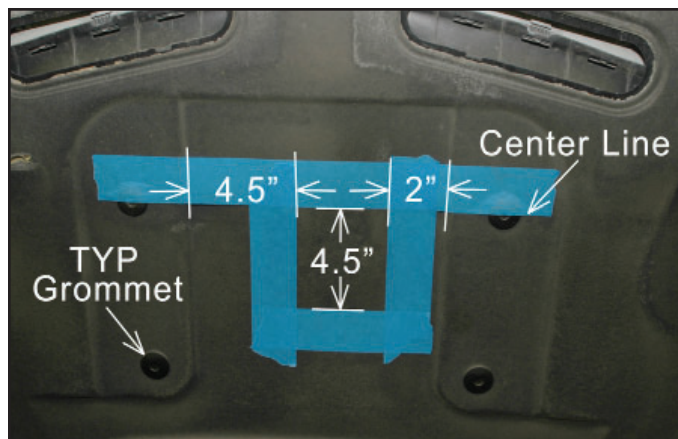

For the intercooler reservoir, starting at the beginning of the curve in the passenger side scoop relief, toward the fender, measure 2.5" down and place a piece of tape. Measure 6" down from that same point and place a piece of tape. From the center line of the grommet, measure 3" toward the fender well, and place a piece of tape, and 6.5" from the same point and add another piece of tape. You can clip the corners off to match the round shape of the reservoir lid should you wish. Remove the area inside the tape lines using a sharp blade and be careful to not damage the underside of your hood.

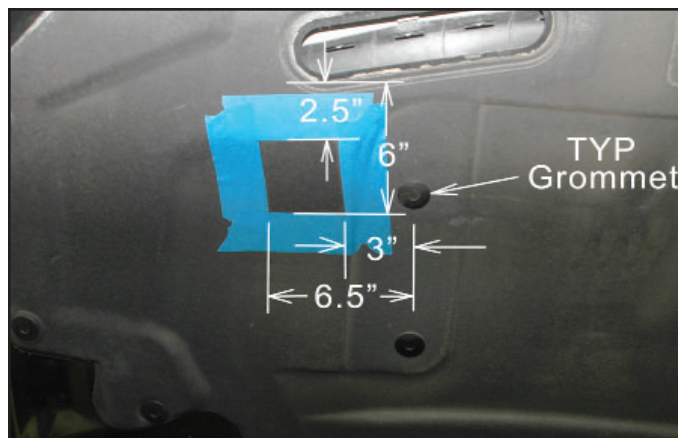

Appendix

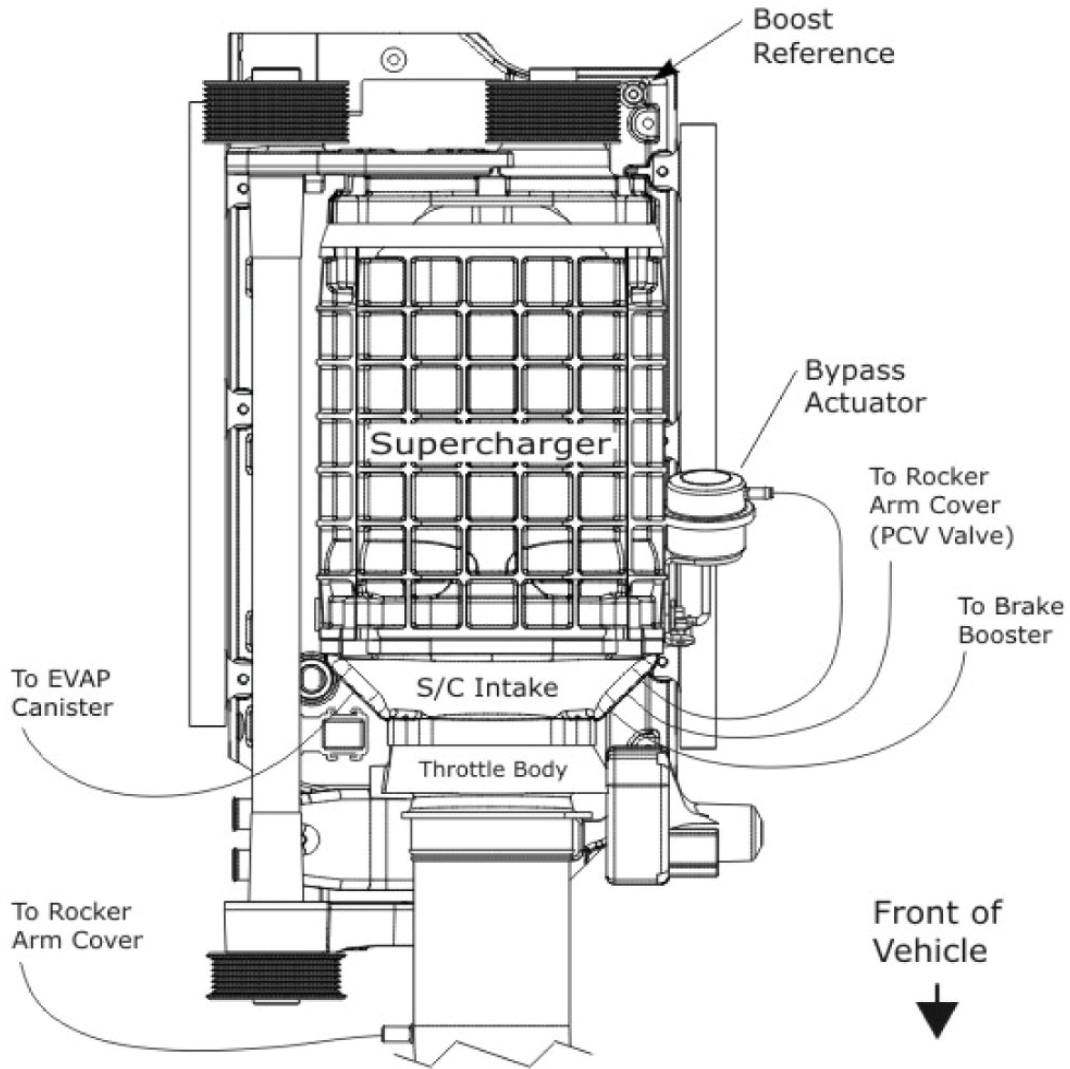

Vacuum Routing Diagram

Appendix

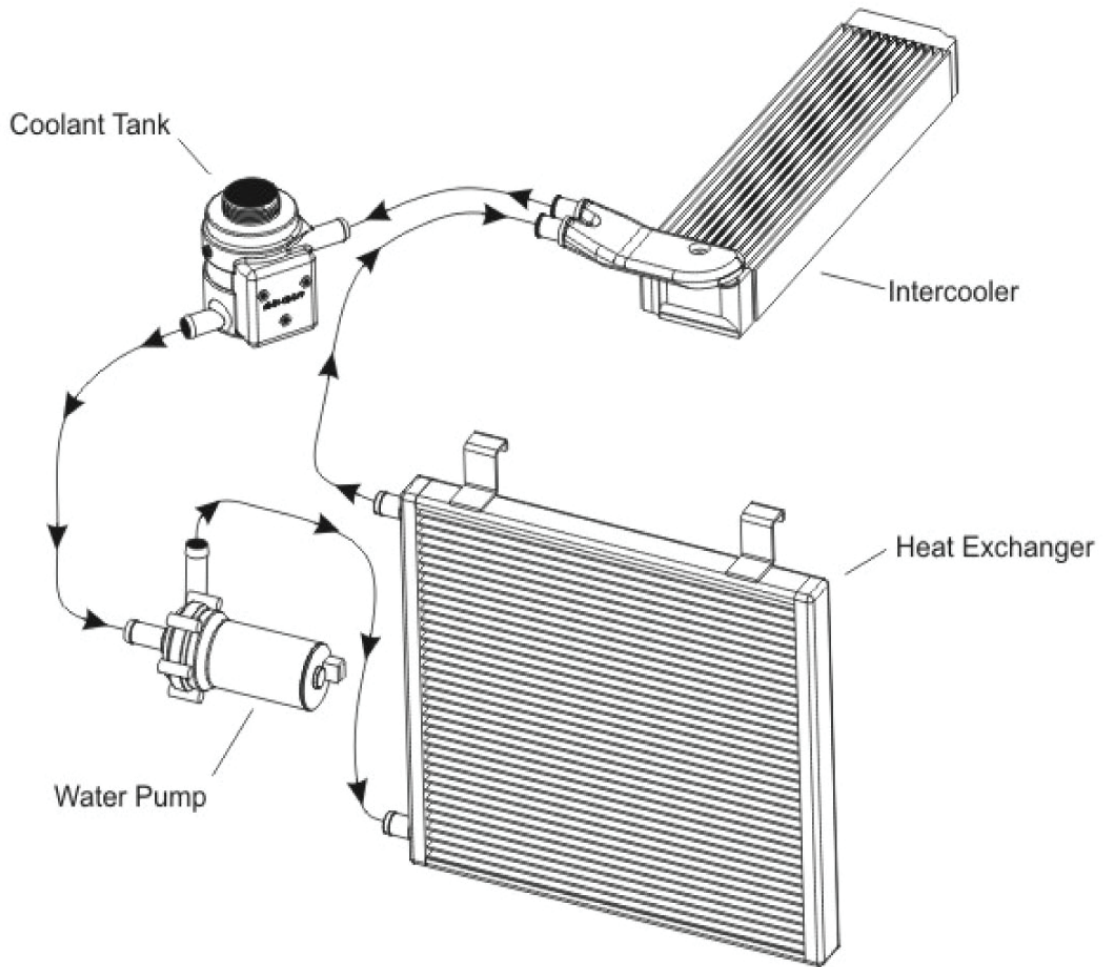

Intercooler Routing Diagram

Appendix

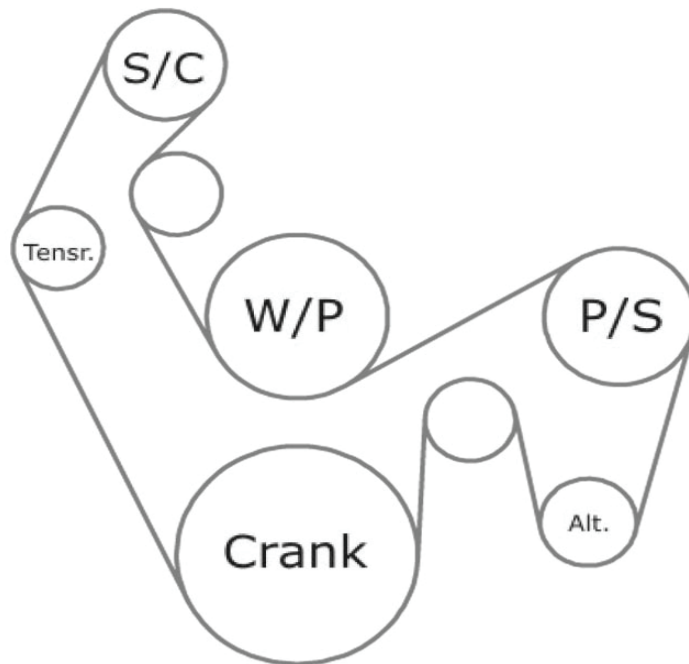

Belt P/N - K060878

Belt Routing Diagram

Notes



If you have questions about your vehicles performance, please check with your installation facility.

This supercharger system requires the use of only premium gasoline fuel, 91 octane or better. It is NOT compatible with E85, Ethanol, Flex Fuels.

NOTE: Your supercharger system is sensitive to corrosion. You must use the vehicle manufacturer specified coolant mixture in the intercooler system as well as your radiator.

Please enjoy your "Magna Charged"
performance responsibly!

MAGNUSON
SUPERCHARGERS