

# MAGNUSON

## SUPERCHARGERS

Installation Instructions for:  
**INTERCOOLED SUPERCHARGER SYSTEM**  
**2008-2009 PONTIAC G8 GT (6.0L)**



Step-by-step instructions for installing the best in supercharger systems.

**\* PREMIUM GASOLINE FUEL REQUIRED \***

### ATTENTION!



**Your MAGNUSON SUPERCHARGER kit is sensitive to corrosion! Use only the vehicle manufacturer recommended coolant for your engine in the intercooler system as well.**

89-89-60-019 Rev H

Magnuson Superchargers  
1990 Knoll Drive, Bldg A, Ventura, CA 93003  
(805) 642-8833  
[magnusonsuperchargers.com](http://magnusonsuperchargers.com)

# INSTALLATION MANUAL

## Magnuson Superchargers Kit GM 6.0L Engine 2008-2009 Pontiac G8

Please take a few moments to review this manual thoroughly before you begin work. Make a quick parts check to be certain your kit is complete (see shipper parts list in this package). If you discover shipping damage or shortage, please call our office immediately. Take a look at exactly what you are going to need in terms of tools, time, and experience. Review our limited warranty with care. When unpacking the supercharger kit **DO NOT** lift the supercharger assembly by the black plastic bypass actuator. This is pre-set from the factory and can be altered if used as a lifting point!

Caution: Relieve the fuel system pressure before servicing fuel system components in order to reduce the risk of fire and personal injury. After relieving the system pressure, a small amount of fuel may be released when servicing the fuel lines or connections. In order to reduce the risk of personal injury, cover the regulator and fuel line fittings with a shop towel before disconnecting. This will catch any fuel that may leak out. Place the towel in an approved container when the job is complete.

**NOTE: This supercharger system requires the use of only premium gasoline fuel, 91 octane or better. It is NOT compatible with E85, Ethanol, or Flex fuels.**

Magnuson Superchargers recommend that you run a minimum of one (1) tank of premium fuel through your vehicle prior to installation of the system to prevent any possible damage that may occur due to running the supercharged engine on lower octane fuel. **DO NOT add octane booster to your vehicle.**

Our Magnuson Supercharger kits are designed for engines in good mechanical condition only. Installation on high mileage or damaged engines is not recommended and may result in engine failure, for which we are not responsible. Magnuson Superchargers is not responsible for the engine or consequential damages.

**Magnuson Superchargers kits are designed for use on stock vehicles. To that end, the alteration or modification of the fuel system, drive train, engine, and/or supercharger outside of stock parameters in any way can result in engine damage or failure for which Magnuson Superchargers is NOT responsible and will void Magnuson Superchargers warranty and CARB certification. Aftermarket engine recalibration devices that modify fuel and spark curve (including, but not limited to programmers) are not recommended and may cause engine damage or failure. Use of non-Magnuson Superchargers approved programming will void all warranties. If you have any questions, call us.**

A new GM fuel filter is recommended at the time of supercharger installation  
Stock spark plugs and stock plug gap is recommended  
Drive belt = Gates# K061025

### Tools Required:

Metric wrench set  
¼" - 3/8" and ½" drive metric socket set (Standard & Deep)  
3/8" and ½" drive foot pound and inch pound torque wrenches  
Phillips and flat head screwdrivers  
Fuel line quick disconnect tools (included in kit)  
Small or angled 3/8" drill motor  
Drain pan  
Hose cutters  
Hose clamp pliers  
Safety glasses  
Metric Allen socket set 3/8" drive  
Shop vacuum cleaner

Helpful Tools: Electric or air driven impact wrench.

Contact information:  
Magnuson Superchargers  
1990 Knoll Drive, Bldg A  
Ventura, CA 93003  
Sales/Tech support 805-642-8833  
Website:  
[www.magnusonsuperchargers.com](http://www.magnusonsuperchargers.com)  
Email:  
[sales@magnusonsuperchargers.com](mailto:sales@magnusonsuperchargers.com)

1. **If your kit has a provided handheld tuner follow the instructions in the provided pamphlet to install your tune. Your handheld tuner may not match the one shown.**



2. Your Intercooler system is sensitive to corrosion. It's very important to use the OEM recommended coolant mixture in your supercharger system as well.



3. Your system requires the use of minimum 91 Octane gasoline fuel. This system is **not** compatible with E85 fuel.



4. On the sidewall of the trunk on the driver side is an access panel behind which the battery is located. Pull off this access panel to expose the battery and disconnect the negative battery terminal using a 10mm wrench.



5. Slowly remove the gas cap to release fuel system pressure.



6. Remove the engine cover by lifting and put aside for later installation.



7. **DO NOT open the drain plug or cap if your engine is hot...BE CAREFUL!** Make sure your engine is cool, and place a drain pan under the passenger side front of the car. Using a medium Phillips screwdriver remove the cooling system drain plug from the bottom of the radiator on the passenger side. Facilitate the draining of coolant by removing the radiator cap. Reinstall the drain plug and radiator cap when draining is complete.

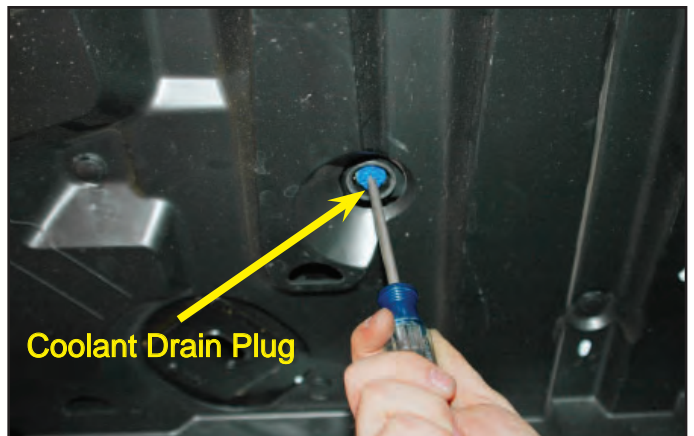

8. Disconnect heater hoses at the heater core and water pump (note: heater core hard-lines will flex). These hoses are banded together and go back to the firewall where you will find spring clips. Using a pair of pliers grasp the spring-clips and pull forward beyond the barb. Then pull the hoses free, be aware there could be fluid in the hoses. We suggest you wrap the hose barbs with a shop towel to catch the dribble and keep clean. These hoses will not be reused.



9. Use a 7mm socket to loosen the clamps holding the air bellows to the MAF Sensor.



10. Use the 7mm socket to loosen the clamps holding the air intake tube to the throttle body and remove the air intake tube. This assembly will not be reused.



11. Unplug the PCV Vent tube from the passenger side hose barb.



12. Disconnect the EVAP Solenoid plug.

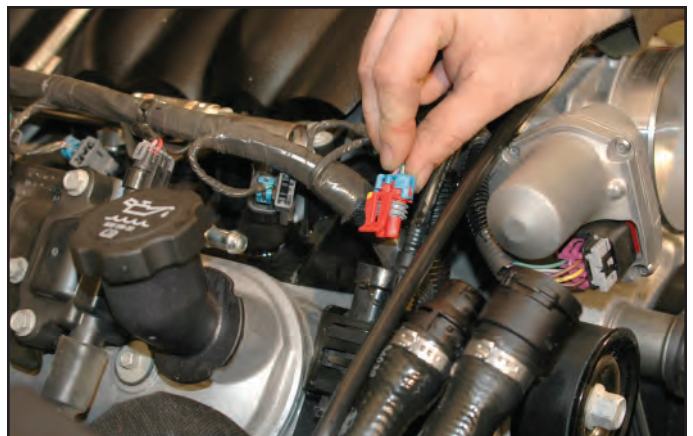

13. Disconnect the MAP Sensor plug.

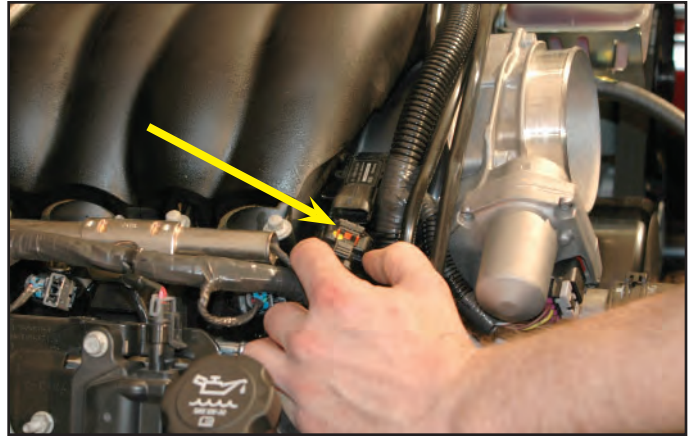

14. Disconnect the eight Injector plugs on each side of the engine.

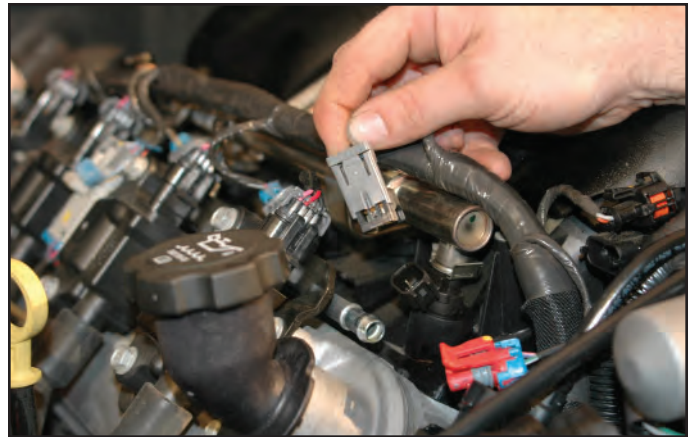

15. Pull the injector wire loom free from the stock intake manifold fuel rail mounting holes.



16. Remove the PCV hose from the rear driver side barb and pull free.

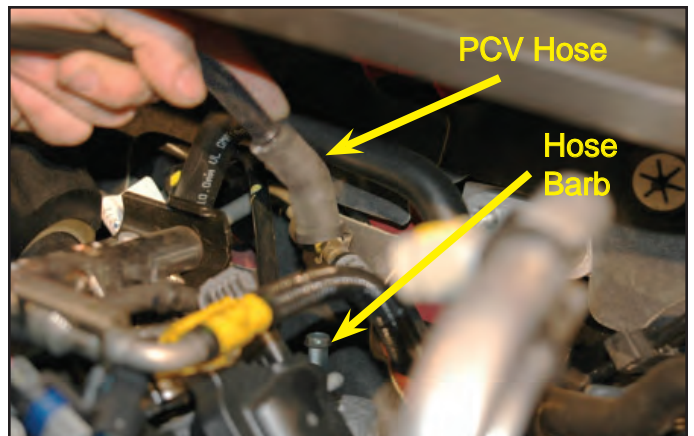

17. Remove the EVAP link by squeezing the yellow saw-tooth tabs and pull free from both ends, put aside for later use.

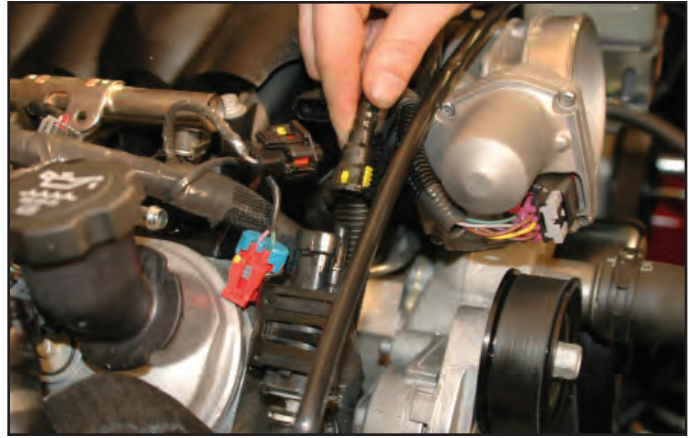

18. Remove the front end of the PCV hose from the front passenger side by squeezing the white tabs and pull free, put aside for later use.

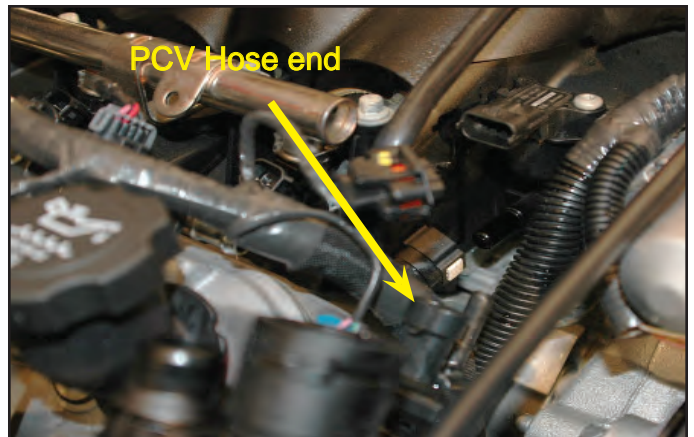

19. Depress the light gray (almost white) tabs of the EVAP tube outlet from the EVAP Solenoid and pull free from both ends, put aside for later use.

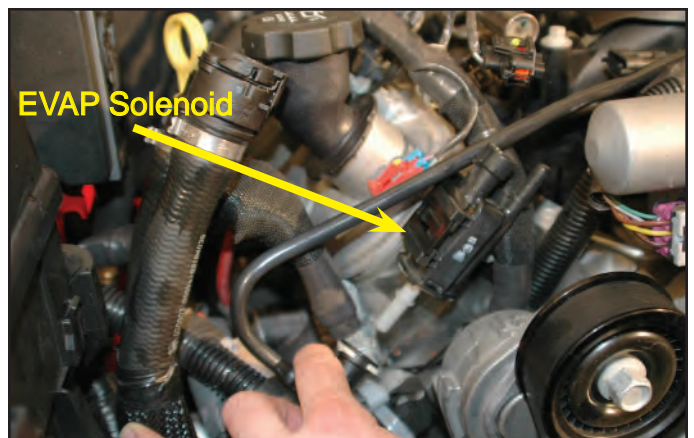

20. Unplug the throttle body control by pulling out the gray tab and pull free.



21. Unbolt the four bolts of the throttle body using a 10mm socket wrench and remove the throttle body, put aside for later use.



22. Pull the vacuum brake hose free from the power brake booster.



**Wear safety glasses while working with fuel lines. Place rags around the fuel line to catch draining fuel and dispose of these rags in an appropriate container.**

23. Pull off the retaining clip, and using the fuel line removal tool supplied, remove the fuel line to the drivers side fuel manifold. To ease removal, pull the fuel line forward, then insert the disconnect tool. Then push the fuel line back, removing it from the manifold. If you have or can improvise a cap we suggest you cap both the hose and the manifold to minimize fuel spillage.

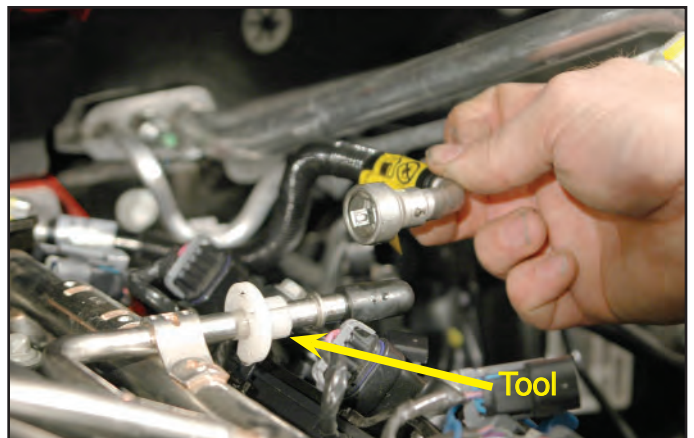

24. Unbolt the intake manifold using an 8mm socket wrench. There are five bolts on each side.





25. Remove the stock intake manifold and put aside, you will be taking some parts off from the bench.



26. Wipe the heads clean of oil using a solvent dampened rag, vacuum the area of dust and debris, and then tape over the intake ports. It's important to maintain a clean work environment.



27. Pull the push pins of the front panel fender wells (four each side) and pull the panels away.



28. For ease of work you can remove the remaining pins and completely take the fender well liners out completely, or you can just bend the panels out of the way as you work.



29. As the case may be, bend the panel toward the rear of the vehicle. Then use a 10mm socket to remove the two front end bolts on each side of the vehicle holding the front body panel to the upper fender section. This shows the fender well removed completely.

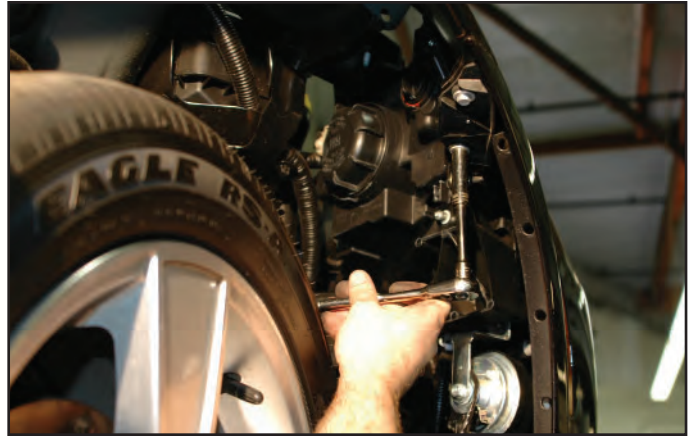

30. On the passenger side of the vehicle, front of the fender well, unplug the connector that splits to go to the parking lights (fog lights), and the side marker illuminating reflector.

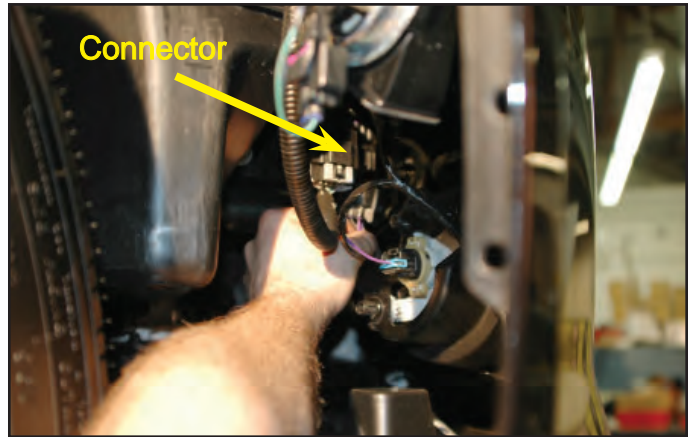

31. Remove the six push pins on the bottom plastic splash shield and the four 7mm bolts, then pull the bottom panel free by pulling aft and away from the front of the vehicle. Set aside for later use.



32. Remove the two push pins and two 10mm bolts from the top of the front end panel connecting the front end fascia to the upper radiator support.



33. Now, this is a little difficult, because it's blind. There are two plastic spring tabs under the headlamp on each side. Accessing from below through where the plastic skid panel was located, you reach up to just below the headlight housing on each side, as you reach up; the plastic has a forward edge bending slightly down. Feel along these plastic flanges and you will notice four slots on each side close together in pairs. Between these slots are the plastic spring tabs. This first picture shows you the tabs after the front panel is removed.



34. Pull down between the outer two slots on the spring tab while slightly pushing the body panel forward away from the vehicle. When the outer spring tab releases, do the same for the inside spring tab. Repeat on the other side of the vehicle. Be sure to have a helper handy for this step because you don't want the front end popping off and getting scratched when it slams to the ground. Pull the front end body panel free from the vehicle and put aside in a safe place where it won't be damaged.



35. Pull off the plastic 5mph bumper guard (Optional).

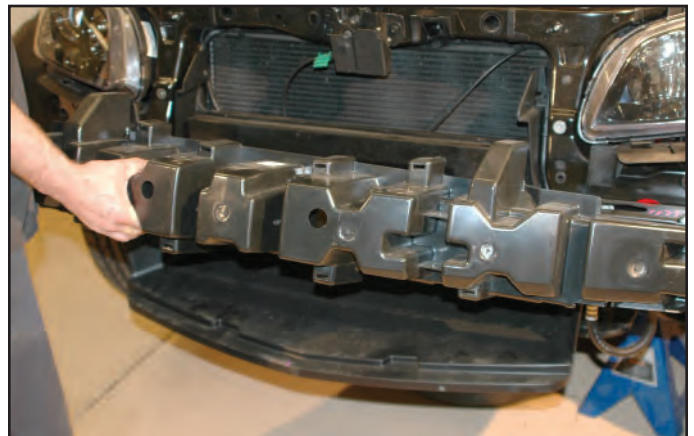

36. Unplug the MAF Sensor plug from the Air box.



37. Unclip the five spring clips that hold the Air-box cover in place, then remove the cover, put aside to reinstall later.



38. Remove the upper radiator hose clamps from both ends of the hose, pull the hose off the hose barbs and put aside for later use.



39. Remove the coolant overflow tube from the hose barb just below the radiator cap, unclip from mounts and coil up on the passenger side of the vehicle out of the way.



40. Reroute the secondary coolant to crossover tube out of the way. You can bend it to run out the other side of the radiator cap.



41. Disconnect the Fan Plug from the Fan Shroud housing.



42. Push down on the top of the Transmission Heat Exchanger hoses so that they disconnect from the mounting clips of the lower Fan Shroud housing.

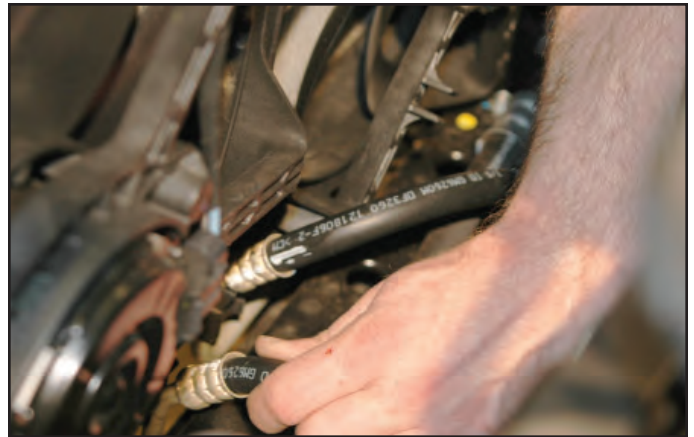

43. Using a medium flathead screwdriver, push down on the top locking pins to release the upper Fan Shroud mount.



44. Pull the Fan Shroud assembly free from the vehicle and put aside for later re-installation.



45. Using a 24mm socket and an impact hammer, remove the Main Harmonic Balancer bolt. This will not be reused. Sometimes using a heat gun or MAP gas torch on the surrounding pulley material helps it to break free from the Loctite used during initial installation. Don't heat the bolt itself and always use care using open flame around engine compartments and combustible material.



46. Install the supplied drill guide using the supplied bolt and tighten to 30 ft-lbs with a 24mm socket and torque wrench.



47. Using a small or angled 3/8" drill and the supplied drill bit, insert the drill into the two guide holes and drill to the second step of the drill bit. (Be sure that you drill all the way to the second step, and use with suitable lubricating oil). **(Caution: wear safety glasses)**



48. Using compressed air, blow the drill shavings out of the holes. **(Caution: wear safety glasses, and make sure that debris doesn't blow into surrounding openings...such as the thermostat housing etc.)**



49. Insert the supplied reamer into the drill, and using a small amount of oil, ream the holes clean until reamer bottoms out in the holes.  
**(Caution: Wear safety glasses)**

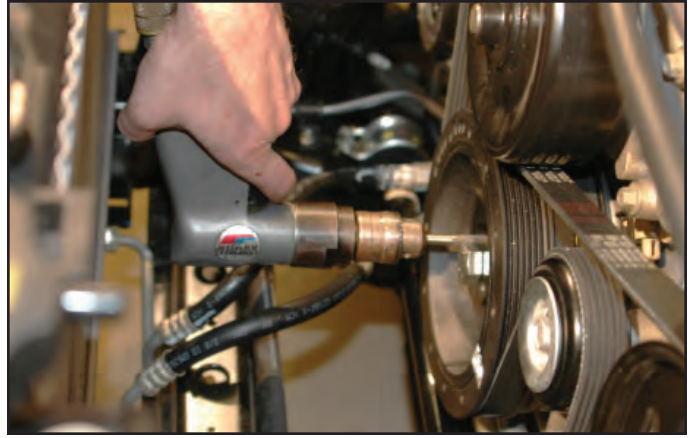

50. Using a 24mm socket, remove the large bolt and drill guide from the engine.



51. Once again, use compressed air to blow out the holes. **(Caution: Wear safety glasses and again be aware of surrounding openings.)**



52. Insert the two supplied hardened roll pins into the drilled holes.

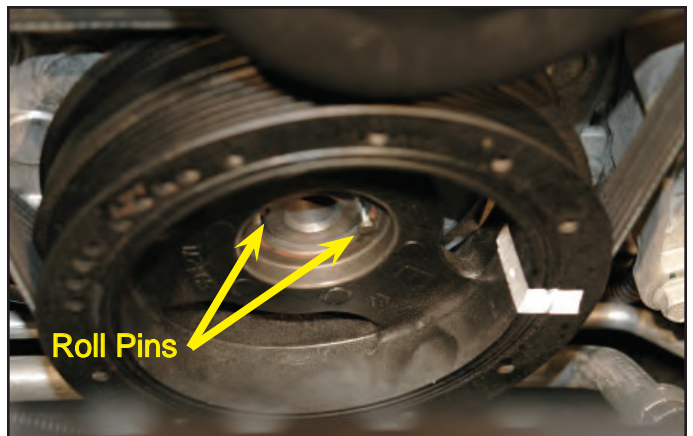

53. Use a small hammer and punch to tap the pins in. Make sure that the pins are in far enough that they do NOT touch the balancer bolt.

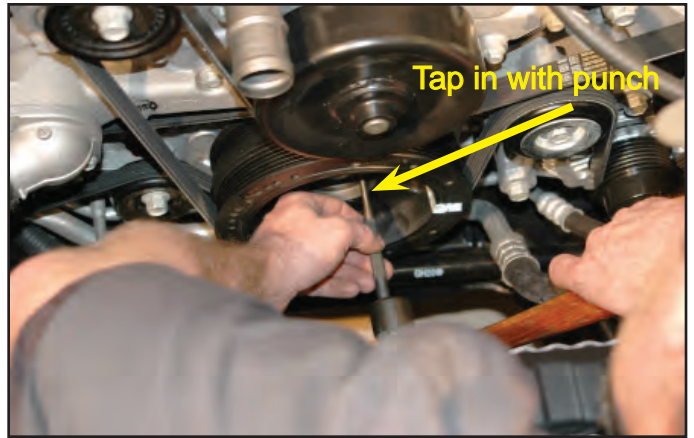

54. Install the new supplied factory GM Harmonic Balancer bolt.

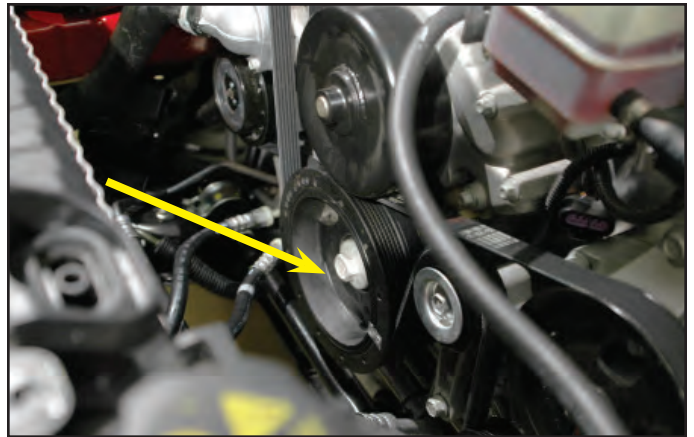

55. Using a 24mm socket tighten the new Harmonic Balancer bolt according to General Motors specifications. Tighten to 50 N-m (37 ft-lbs) then tighten an additional 140 degrees using a torque angle meter.



56. Using a 15mm socket on the Tensioner Pulley bolt, spring the pulley down to remove tension on the drive belt and remove the belt when tension has been released.

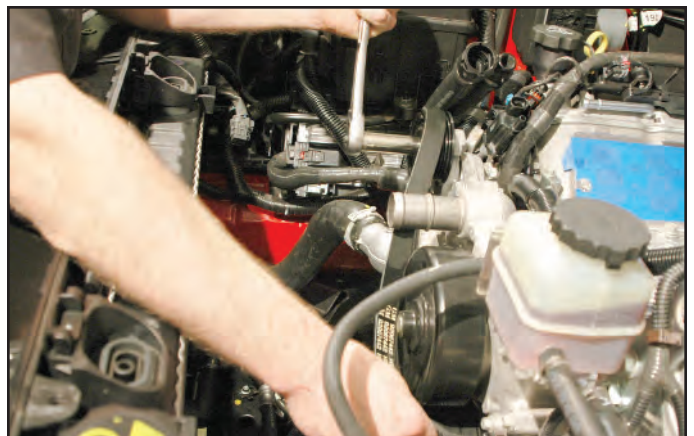



57. **Note: Mid year 2009, GM switched water-pump styles. This affects the G8 GT 6.0L only.** If you have the water-pump with the upper radiator hose barb on the driver side of the vehicle, skip the steps pertaining to the tensioner bracket following (steps 58-63).

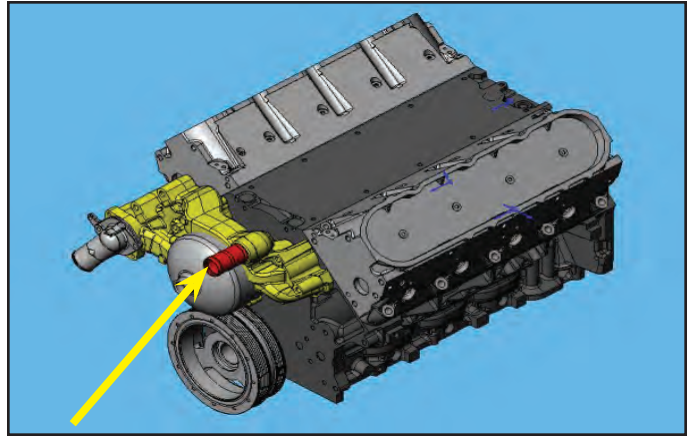

58. If your vehicle has the water-pump with the upper radiator hose barb on the passenger side, continue to follow these procedures below (steps 59-63) for the Tensioner bracket change.

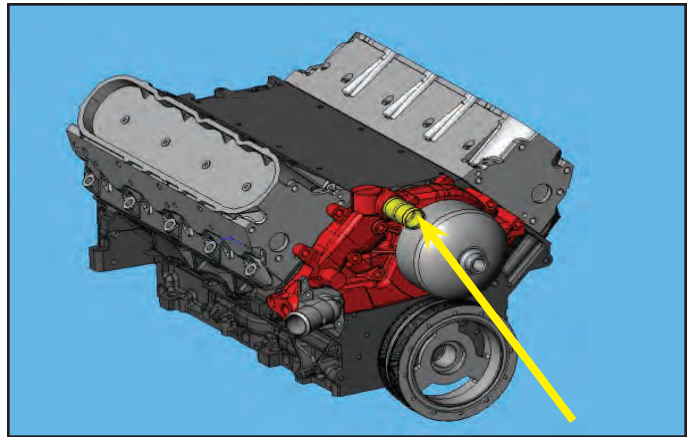

59. Remove the stock pulley from the tensioner mount using the 15mm socket. Put this pulley aside for later use.

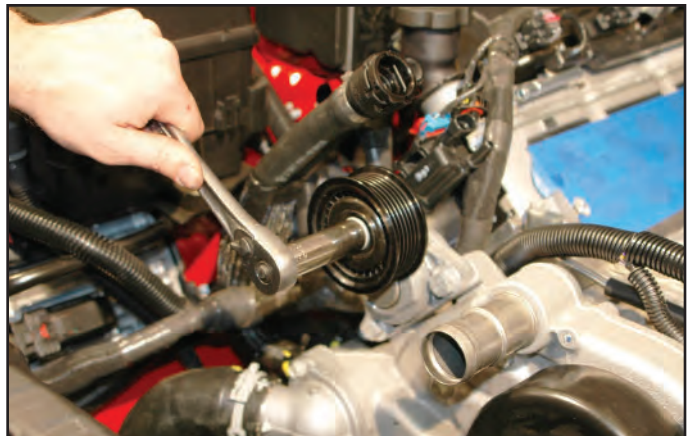

60. Again using the 15mm socket, remove the two tensioner bracket pulley bolts and remove the stock Tensioner bracket.



61. Mount new Tensioner mounting bracket using one stock bolt and new shorter 6mm Allen countersunk bolts. Torque to 40 ft-lbs.

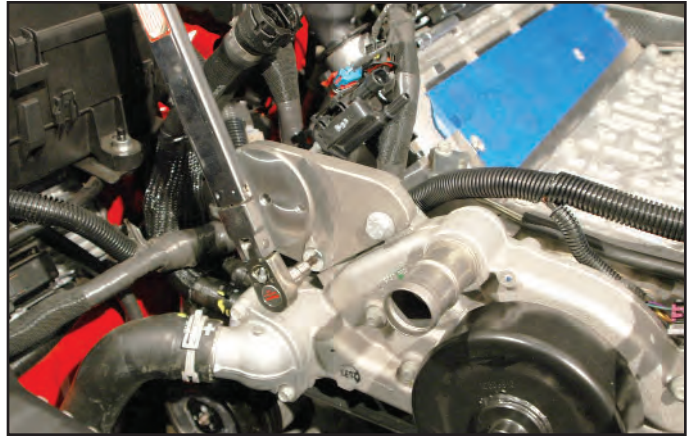

62. Attach new Tensioner Pulley assembly, torque to 50 ft-lbs.

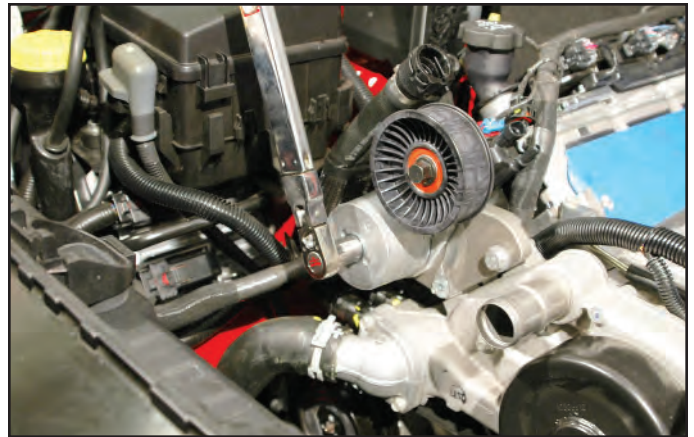

63. Remove pulley from assembly and replace with stock pulley removed in prior step.



64. Using a medium flathead screwdriver, pry up on the radiator release tabs. They will slide up easily until they hit a "stop".



65. This stop is accessed from the front side of the release tab, and using a small flathead screwdriver you depress the stop allowing you to pull the radiator mount lock free from the upper radiator mount.

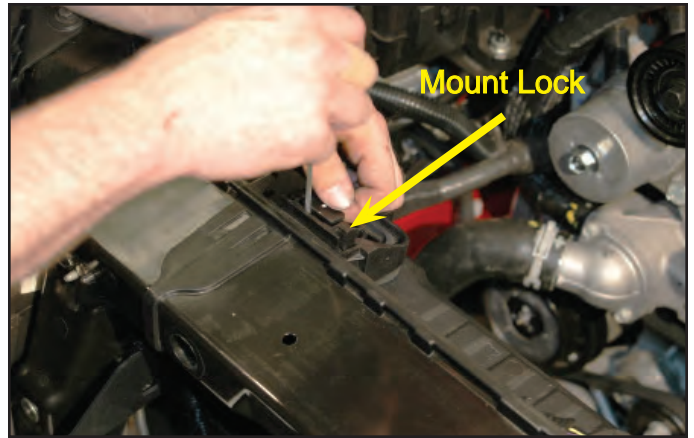

66. This picture is a close-up of the locking tab that needs to be depressed to allow the mount lock to be removed.

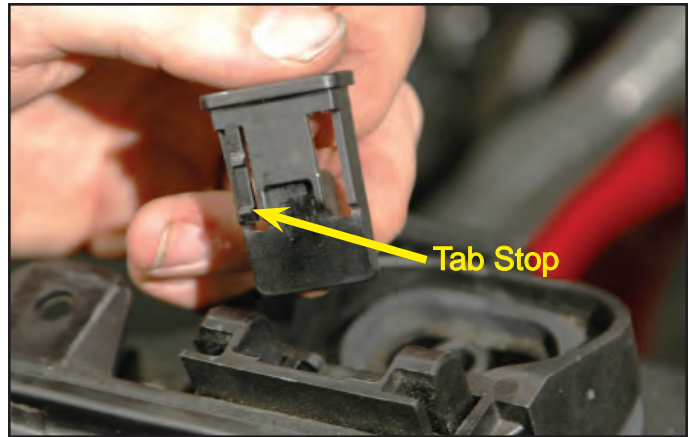

67. From inside the slot where the lock tab was removed, use the small flathead screwdriver to lever the final locking tab inward, allowing the upper radiator mount to be pulled up and free of the frame.

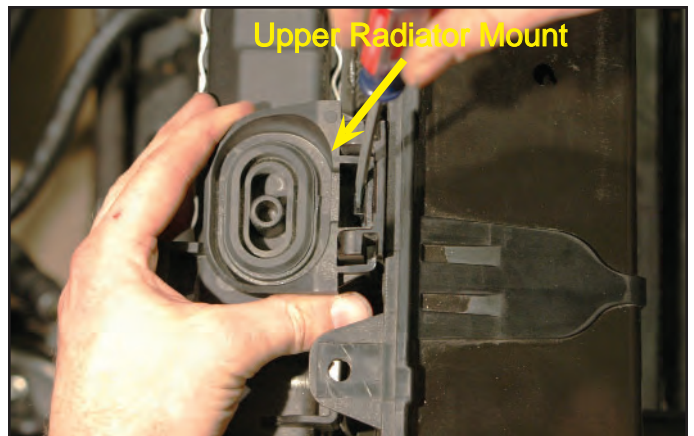

68. This picture shows the mount lock being removed. Repeat on other upper radiator mount. The radiator can now be pivoted backward toward the engine block for heat exchanger installation.

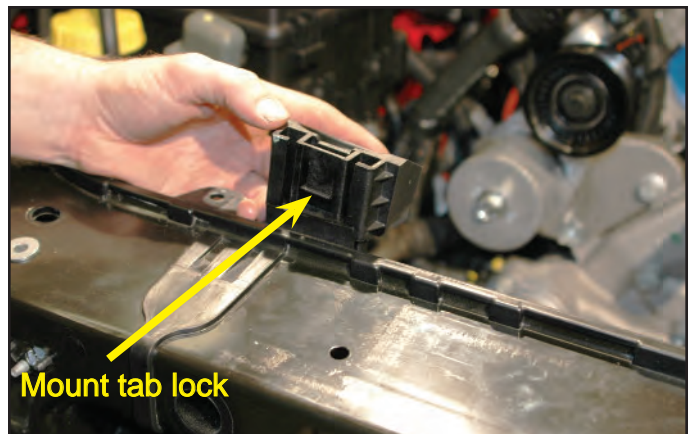

69. Remove the rubber seal from the top of the A/C Condenser. This will get modified and re-installed in a later step.

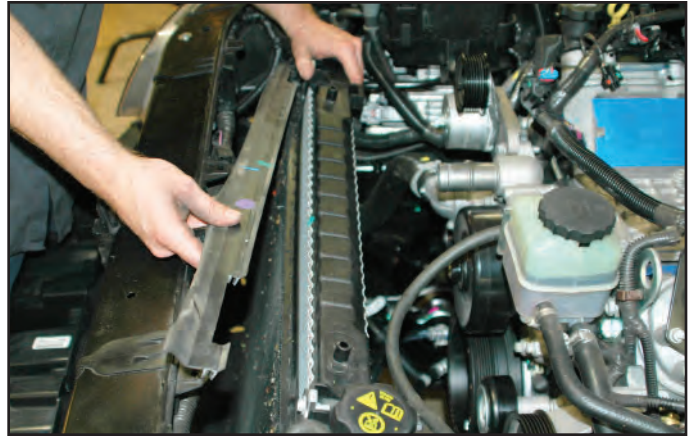

70. Apply the two 1/2" x 15" and the two 1" x 3" rubber strips to the Heat Exchanger as shown.

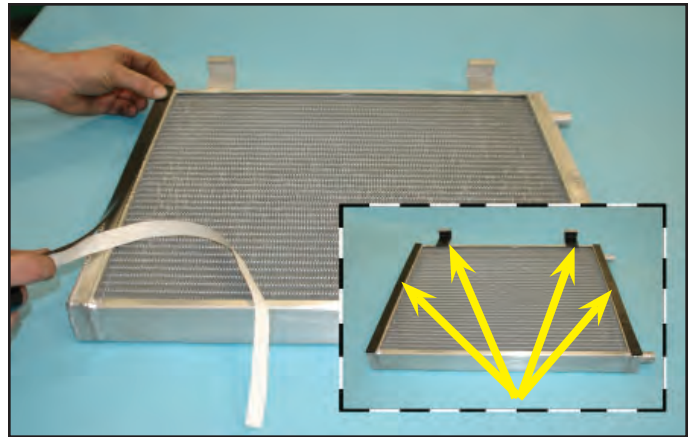

71. Now, slide the Heat Exchanger down in front of the A/C Condenser, hooking the two top brackets onto the condenser.



72. Position the Heat Exchanger so that the end tank just clears the plastic condenser mount located at the lower driver side of the condenser. Also be sure not to pinch the small hose coming from the windshield wiper reservoir between the heat exchanger and condenser.



73. Next, trim the rubber seal in the two spots as shown. This will allow the seal to re-install around the Heat Exchanger brackets.

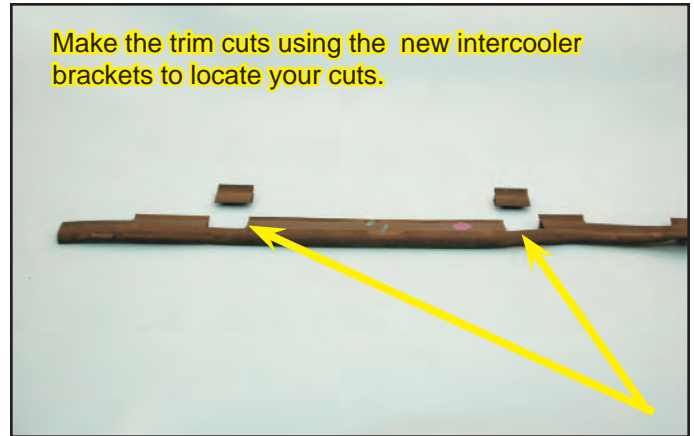

74. Now re-install the modified rubber seal onto the condenser. Refer to steps 64 thru 68 to reinstall the plastic upper radiator mounts to secure the radiator back in place; then reinstall the bracket locking tabs.



75. The following two steps are prep for later procedures: The Intercooler pump plate and bracket mount will now be located. Use the existing hole located just to the driver side of the lower cross-member as one hole. This existing hole is toward the center from the existing 5/8" diameter hole located in-line with the driver-side edge of the crank pulley. Mark the second hole using the mounting plate as a guide. Use the supplied self tapping screws as your drill bit, drill and tap your hole.



76. Open and tap the existing hole also using the self tapping screw as shown. Set the self tapping screws aside for later mounting of the intercooler pump.



77. With the radiator mounted back in its stock location, you can now re-install the electric fan assembly.



78. Plug the electrical connection back into the fan assembly.



79. Also push the two transmission cooler lines back into the retainer clips on the fan assembly.



80. You can now re-connect the coolant overflow hose back to the hose barb on the radiator neck.



81. Re-install the upper radiator hose and secure in place with the stock clamps. The coolant overflows can now be relocated to the stock locations and clips on the radiator fan shroud.

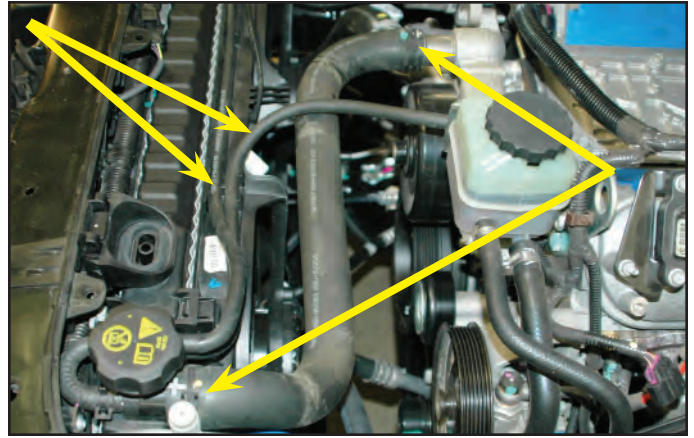

82. Locate the ETC connector on the engine harness. This will need to be extended with the supplied extension harness.

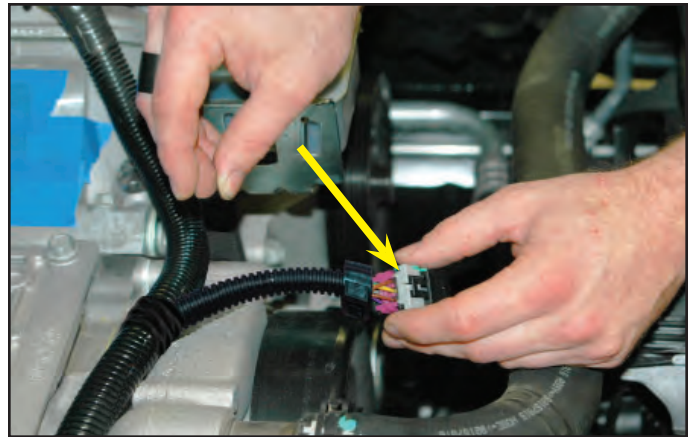

83. This is the provided ETC connector extension harness.



84. Plug the extension into the existing ETC connector, route the wires adjacent to the existing wiring harness to the driver side of the engine. You can add a couple of wire ties to hold the extended wires to the existing split loom running under the steam pipe.



85. **NOTE: Steps 85-91 are for 2008-2009 vehicles ONLY, with upper radiator hose on the passenger side of the vehicle (reference steps 57-58):** With a screwdriver, remove the stock coolant hose from the stock steam pipe.



86. Using a 10mm socket wrench, remove the two bolts that secure the steam pipe to the engine.



87. Remove the OEM steam pipe from the vehicle.

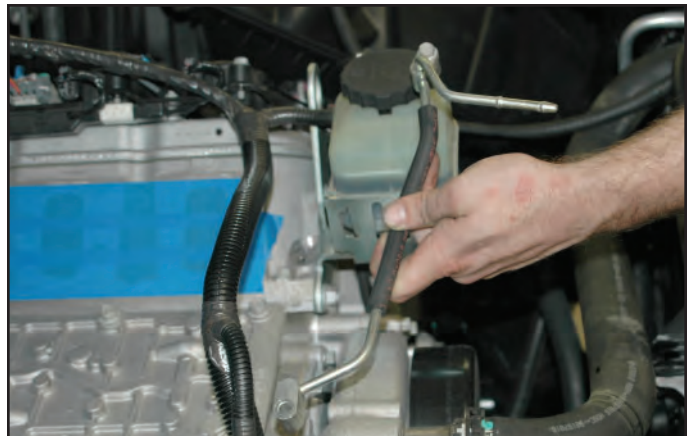

88. Take the supplied new steam pipe, and install the two new O-rings onto the pipe. Be sure to lubricate the O-rings with the supplied Lubriplate lubricant

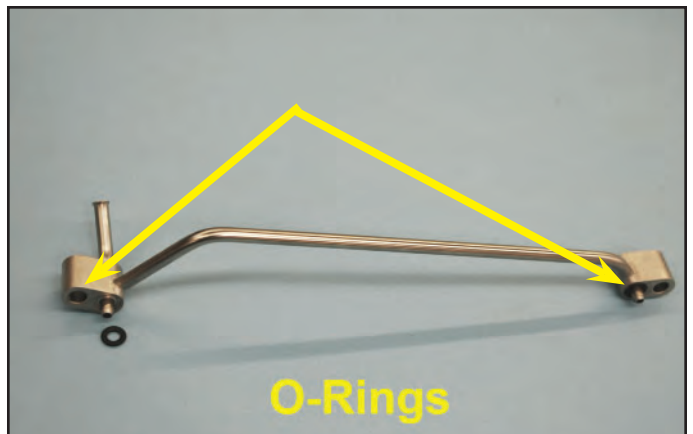



89. Now install the new steam pipe onto the block and torque the stock bolts to 106 in-lbs.

**Note: Route the loom from step 84 under the new steam pipe.**

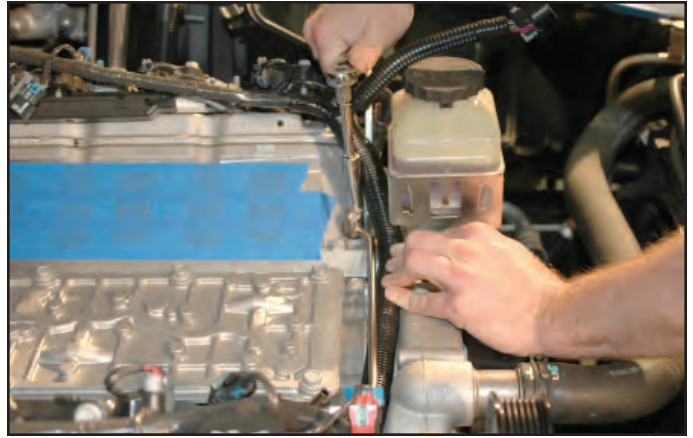

90. Install the supplied 1/4" coolant hose to the steam pipe nipple.

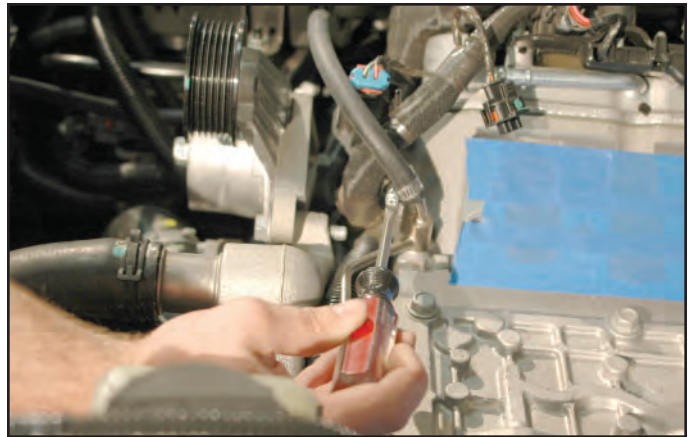

91. Join this new hose to the stock hose using the supplied hose mender. Tighten with supplied hose clamps at all connections.



92. Disconnect the main coil connector from the coil rail.



93. Disconnect all plug wires from the coils on both sides of the engine.



94. Remove five 10mm bolts from the coil brackets on each side, and remove the coil brackets from the engine to be modified below.



95. Remove the plastic wire loom covers from the coil bracket assemblies from both sides of the engine.



96. Trim the plastic cowl at the center of the run as shown and described. From the center seam, trim off 4-1/4" on the driver side. From the center seam, trim off 3" on the passenger side.

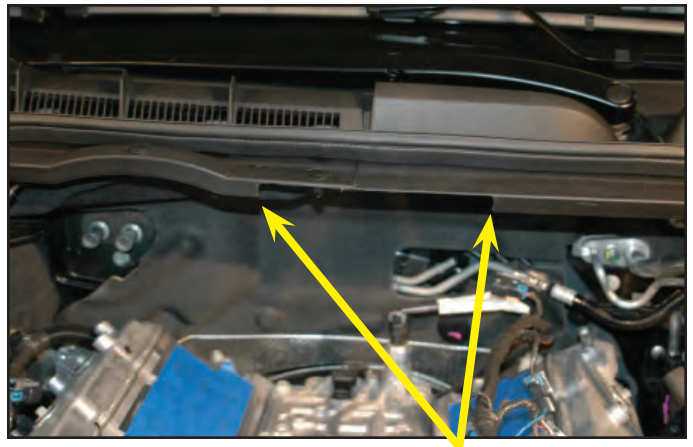

97. Use a T-25 Torx socket to remove the MAP sensor from the stock intake manifold.



98. Use a 10mm socket wrench to unbolt the stock Fuel Rails from the stock intake manifold.



99. Unsnap and remove the clips holding the fuel injectors to the stock fuel rails, and remove the injectors. **Note: There will be fuel leakage from the injectors and fuel inside the fuel rails. Take care to have an appropriate catch pan and shop rags handy, then dispose of the fuel collected and any rags used properly.**



100. Use a 10mm socket wrench to remove the fuel rail bolts connecting the supplied fuel rails to the new intake manifold. Use the supplied Lubriplate lubricant to lube the O-rings of the stock injectors and insert the eight stock injectors into the new manifold below the loosened fuel rails.

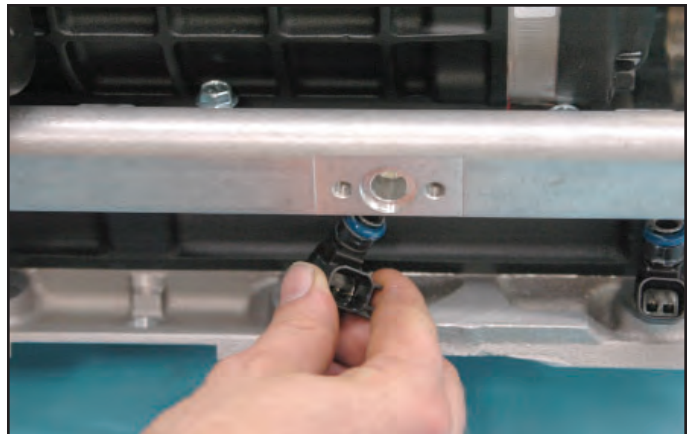

101. Lubricate the O-rings of the stock injectors, align and carefully press the fuel rails down onto the installed injectors.

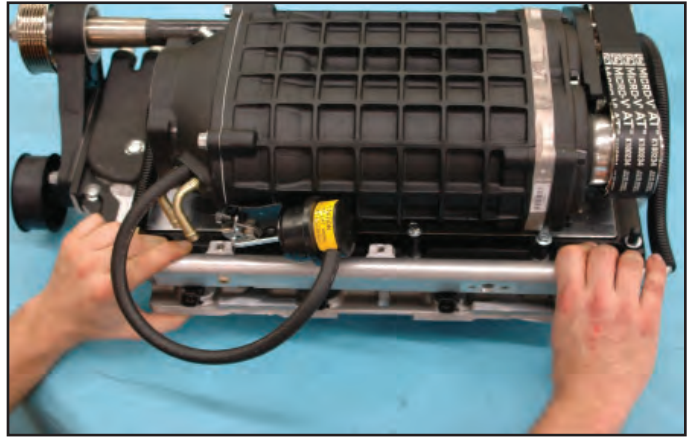

102. Reinstall the fuel rail bolts and torque to 106 in-lbs. Verify your torque wrench is correctly set to inch-pounds.

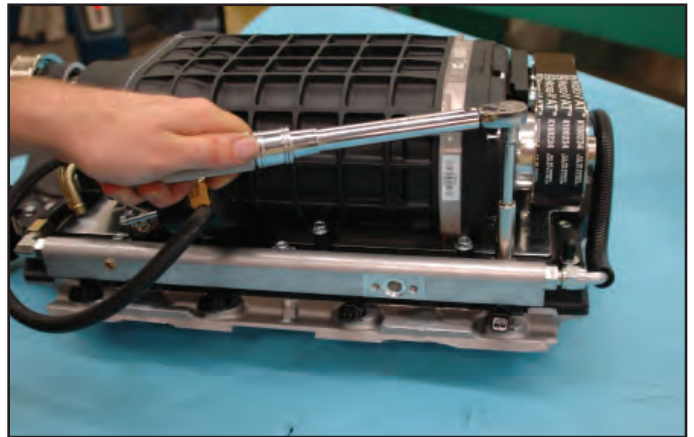

103. Remove the O-ring from the stock throttle body connector groove.



104. Install the MAP sensor on the new Supercharger assembly.

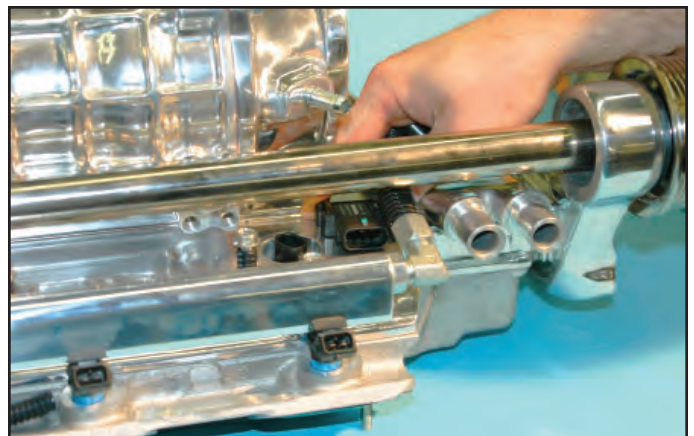

105. Snap the provided intake manifold gaskets onto the new Supercharger intake manifold.

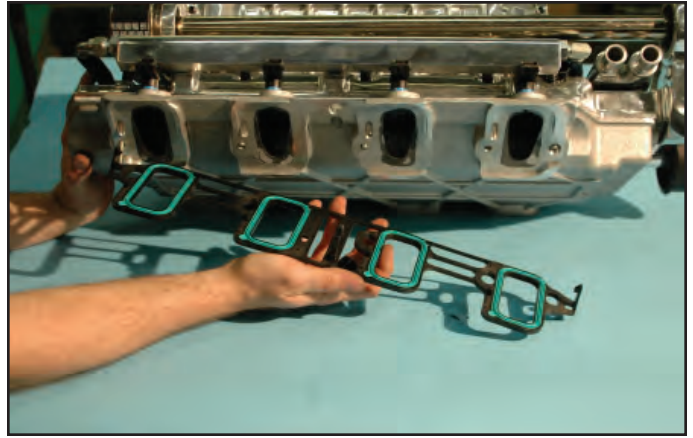

106. Install the stock O-ring for the throttle body into the groove on the Supercharger assembly.

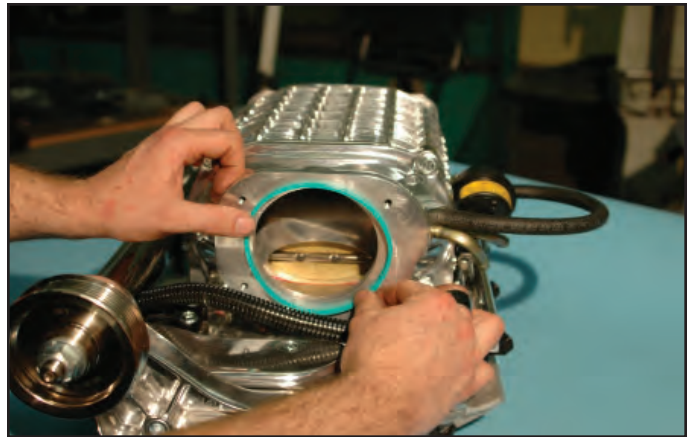

107. Install the Throttle Body on the supercharger using a 10mm socket wrench, torque the bolts to 106 in-lbs. Make sure you are using the correct settings for your torque wrench.



108. Using the supplied Lubriplate lubricant, lube the O-ring and insert it into the groove on the driver side fuel rail.



109. Install the fuel supply manifold on the fuel rail, and torque the 106 in-lbs. Verify your torque wrench settings.

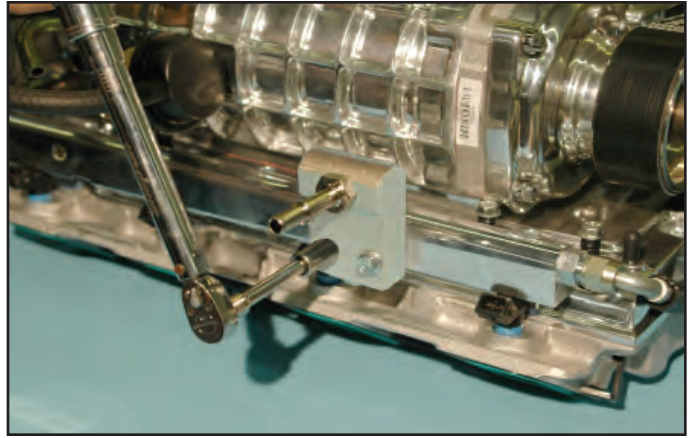

110. Remove the tape from the heads and lubricate with silicone spray, mild soap, or light lubricant to allow the new manifold to slide around a bit to align properly. Get another pair of hands to help, and carefully lift the supercharger assembly into the engine.



111. Remove the split loom spacers from the intake manifold bolts so that the bolts can drop down to engage the threads on the heads.



112. After an initial hand tighten, torque the bolts down to 106 in-lbs. Torque from the center out using a criss-cross pattern. Make sure you check your torque wrench settings.



113. Plug in the MAP sensor electrical connector.



114. Re-attach the modified coil brackets to each side of the engine using the stock hardware. **Do NOT install the second bolt back on the passenger side at this time.** Torque all remaining bolts to 106 in-lbs. Again, verify your torque wrench settings. Reattach the main coil connector at this time (removed in step 92).



115. Plug in the injector plug connectors onto the injectors on each side of the engine. Make sure to route and stuff the wiring to avoid moving components.



116. Plug in the Throttle Body connector.



117. Attach the stock plug connectors back on to the coils on the coil brackets.

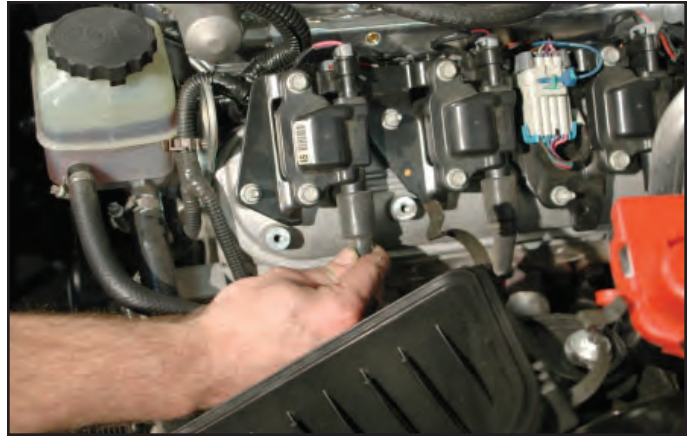

118. Attach the fuel line to the fuel manifold on the driver side of the supercharger. Be sure to attach the safety clip as well.



119. Cut two sections of the supplied 5/8" hose. One @ 34" and one @ 35". You will reuse the four stock clamps from the removed heater hoses. The 34" hose goes to the passenger side hose barb on the firewall, and the near hose barb on the water pump. The 35" hose goes to the center most hose barb on the firewall and goes to the front hose barb on the water pump. This is a 3/4" barb. So, lubricate the end of the 5/8" hose to facilitate installation. Slide the hose clamps into position using pliers (or hose clamp pliers) on both the firewall and water pump ends.

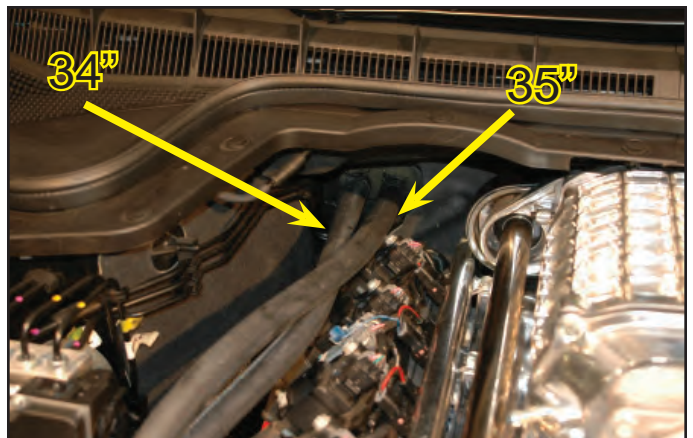

120. Using the supplied 6 x 45mm bolts, 1" spacer, and double hose clamp, install the clamp with the mount hole facing down over the just installed two heater hoses. Slide the bolt through the clamp, and put the spacer on the bottom of the bolt. Install the bolt into the second hole of the coil bracket on the passenger side (the one left out in step 114). Torque bolt to 106 in-lbs.





121. Loosely add zip ties to hold the hoses together, and add strips of split loom to prevent chafing on the fuse box.

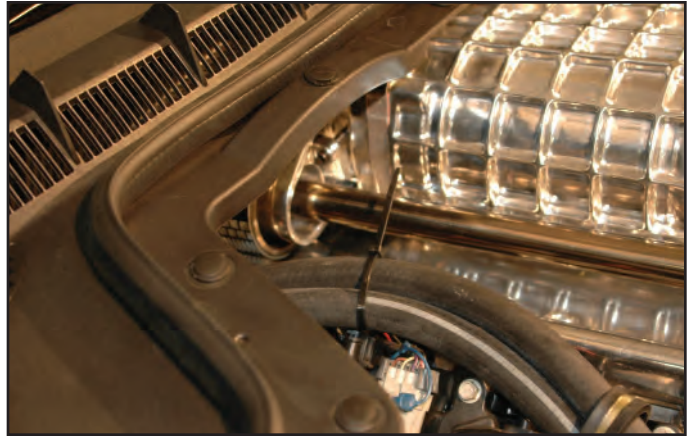

122. Plug in the EVAP sensor electrical connection.

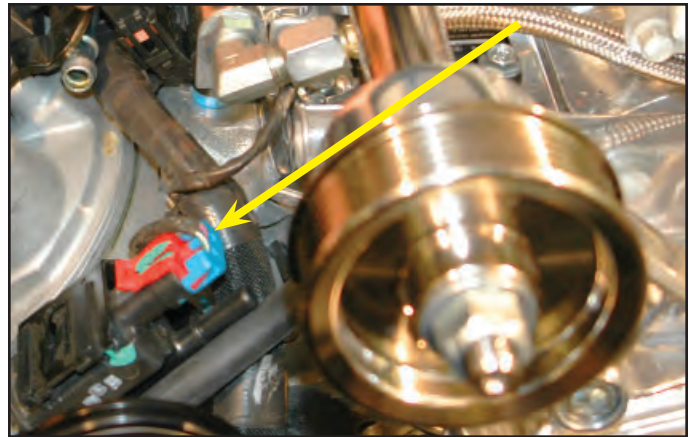

123. Use a sharp blade and split the ends of the EVAP lines and remove the three fittings.



124. Cut a piece of the supplied 5/16" hose to 40" long and install the right angle fitting removed in the prior step. No clamp is necessary.



125. Thread the open end of the 40" (5/16") hose under the front of the supercharger assembly, below the throttle body, and back along the coil bracket. Connect the right angle end to the EVAP solenoid as shown.

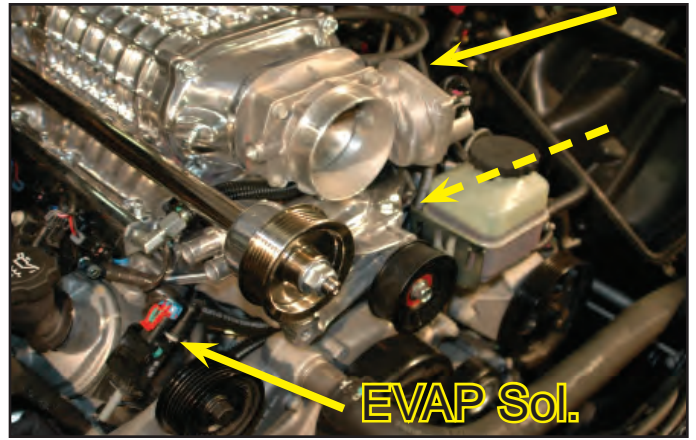

126. Insert one of the fittings removed in step 121 into the open end of the 40" hose and attach the fitting to the firewall connection as shown.



127. Cut 20" of the supplied 5/16" hose and install the remaining end (removed from step 123) onto the EVAP Solenoid as shown.

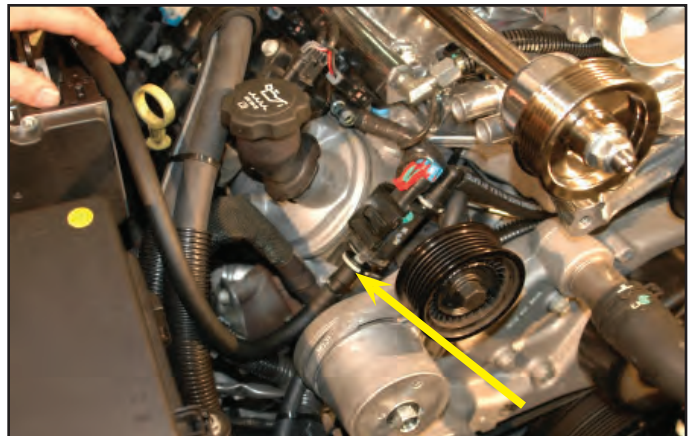

128. The other end of this hose connects to the supercharger hose barb as shown. Add zip tie at the heater hoses near the oil fill cap.

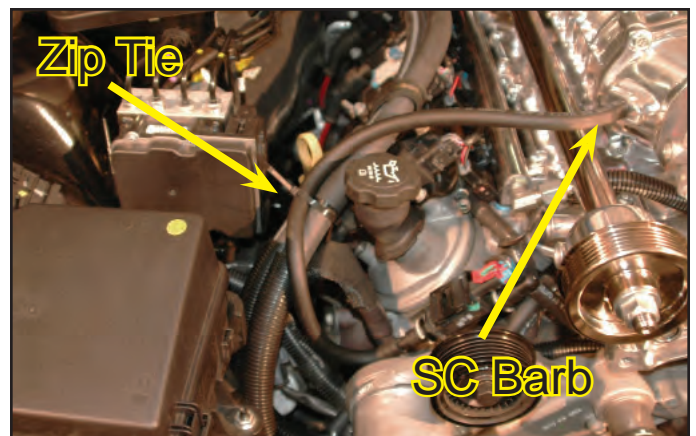

129. Cut 20" of the 3/8" hose, install on the PCV valve barb at the rear on the driver side-rear valve cover as shown.



130. Connect the other end to the front of the supercharger barbs on the driver side as shown.



131. Cut 20" of 11/32" brake hose supplied. Attach the stock check valve on one end.



132. Install check valve at the brake booster as shown.



133. The other end of this hose connects to the vacuum barb on the supercharger inlet as shown.

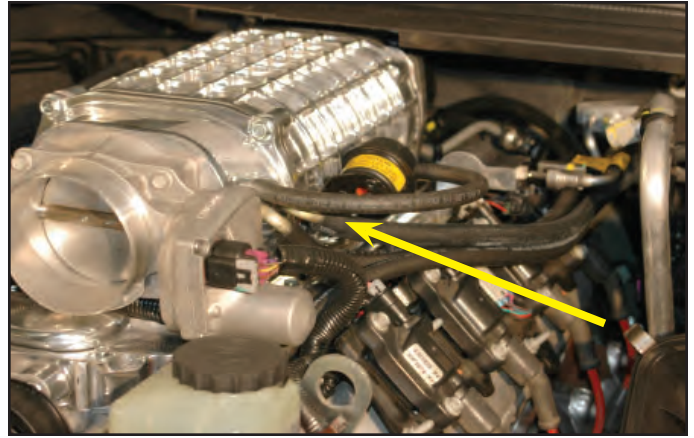

134. Add zip ties to anchor the vacuum hoses as shown.

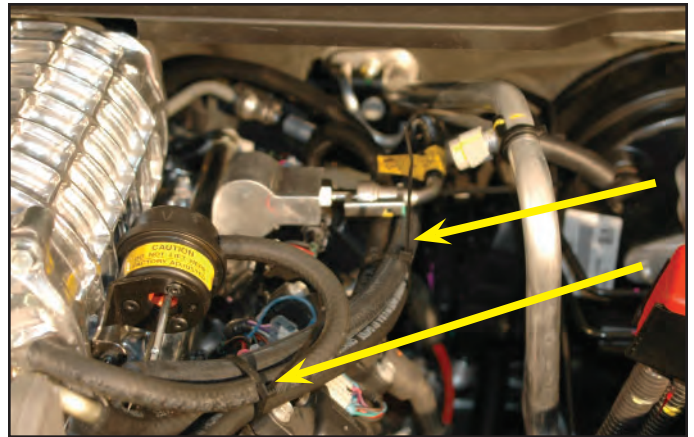

135. Cut a 16" section of the supplied 3/8" hose. Connect one end to the hose barb on the front passenger side, above the valve cover. The other end will connect to the inlet tube to be installed later.



136. Near the front on the passenger side of the supercharger are the two IAT wires exiting the intercooler lid. Attach, crimp and shrink the wire splice connectors to these IAT plug wire ends as shown in the first image. Route the wires from passenger side under the supercharger inlet as shown.

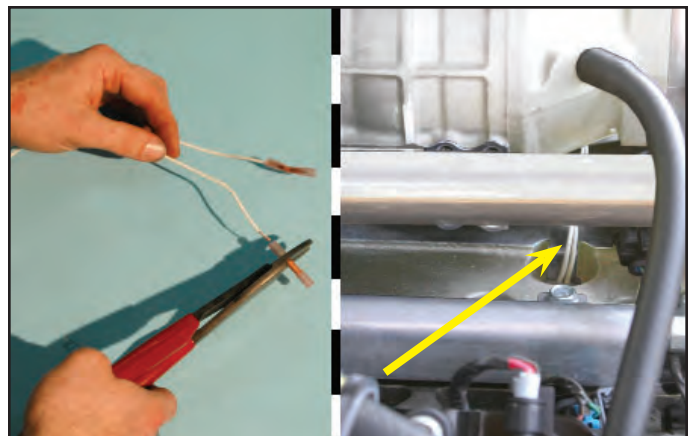

137. Uncover the wire loom to the MAF connector that hooks to the air box. Cut the brown with-white stripe, and the brown with-red stripe about 2" from the connector.



138. Crimp and shrink the wires from the MAF sensor you just cut, to the connectors at the ends of the IAT sensor wires you routed under the supercharger inlet in step 136. The selection of the wire to connect to either terminal is of no consequence.

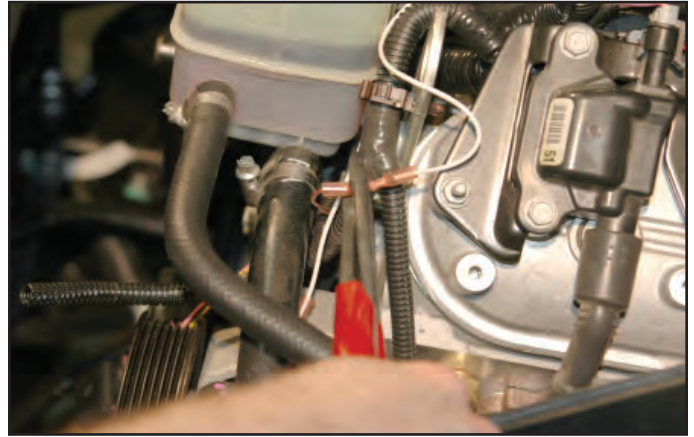

139. Make sure you heat-shrink your connections to avoid moisture contamination and ensure a good connection.



140. Re-place the split loom to the MAF plug. Cut a piece of split loom (supplied) to cover the new wires under the supercharger inlet (approximately 19") to the IAT sensor wire ends.

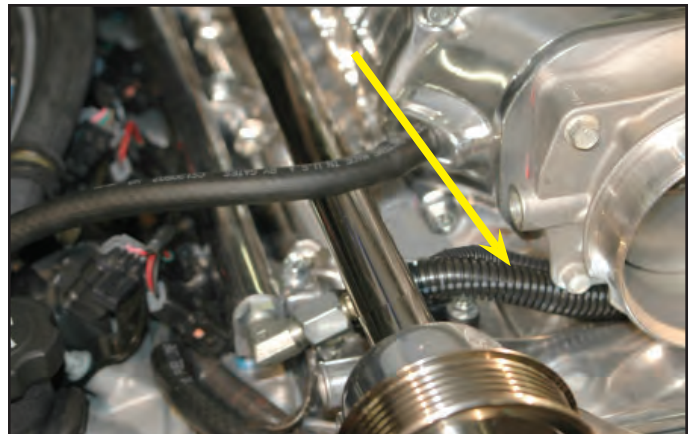

141. Ensure that the wire loom does not contact the jack-shaft and that the wires are covered completely.

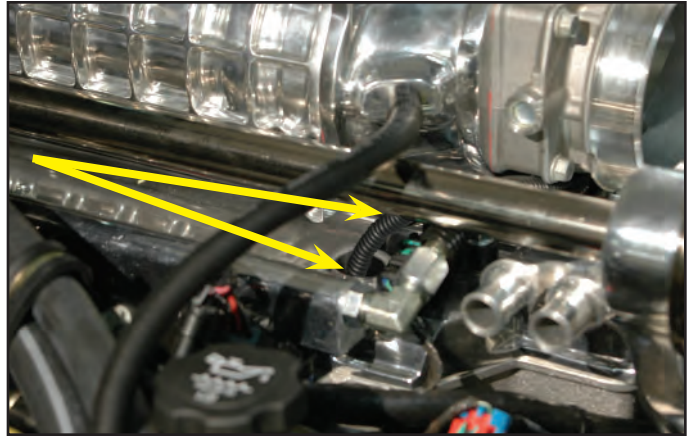

142. **IMPORTANT: Refer to the images and information in steps 57-58 to determine which water-pump/situation you have.** In either case the procedure is easier using a helper. If your water pump is on the passenger side, you changed out the tensioner, and you route the supplied drive belt as shown in the '08 drive belt diagram shown on the last page of this manual. Use a 15mm long wrench to spring the tensioner and allow the belt to be installed.



143. If your water-pump is on the driver side, you did not change out the tensioner. In this case, you route the supplied drive belt as shown in the '09 drive belt diagram on the last page. Without a helper, use your longest handle wrench on the tensioner to get the belt over all the pulleys. With the tensioner held compressed, push the idler firmly toward the tensioner pulley. Tighten the idler pulley bolt in this position. Now release the lever on the idler tensioner allowing the belt to be put under proper tension. It's a good idea to go through this process again after the vehicle is first driven to adjust for stretching.



144. Install the air box filter and cover, snapping the retaining clips into position.



145. Plug the MAF connector into the MAF sensor on the air-box as shown.

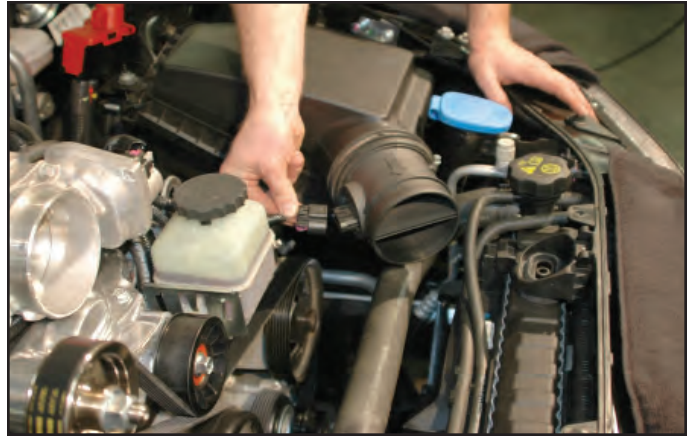

146. Assemble the Intercooler Pump and bracket mount.



147. Mount the assembly using the holes you prepped in step 75-76. Be careful to not strip the self tap screw threads. Do not over tighten!



148. To mount the intercooler reservoir you will use the fuse box mounting bracket as shown. Remove the nut with a 13mm socket.



149. Install the Intercooler bracket mount as shown.



150. Attach reservoir to the mounting bracket with the three supplied bolts.



151. Drill two 1-1/4" holes through the plastic cowl for the heat exchanger as shown. Connect the holes by cutting the plastic between them, clean and dress the hole to remove any sharp edges.

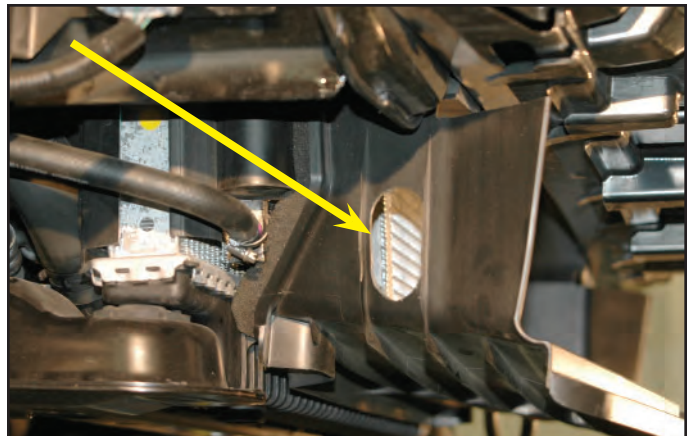

152. Cut a 46" section of the supplied 3/4" hose and connect one end to the lower heat exchanger barb using the provided clamp. Route the hose through the holes, up over the lower radiator hose.

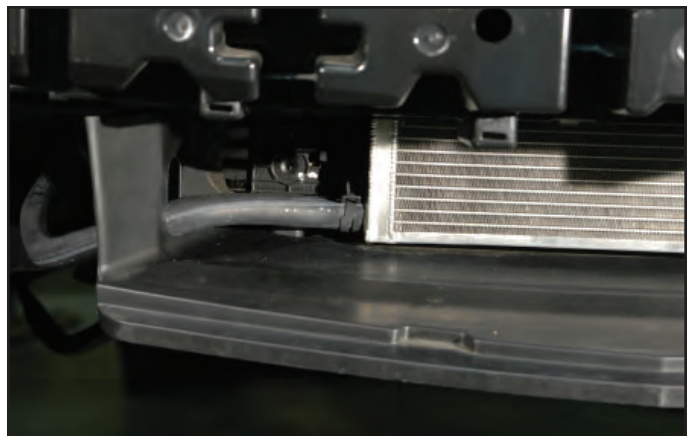



153. Connect the free end of this hose to the Intercooler pump discharge barb using the provided clamp.

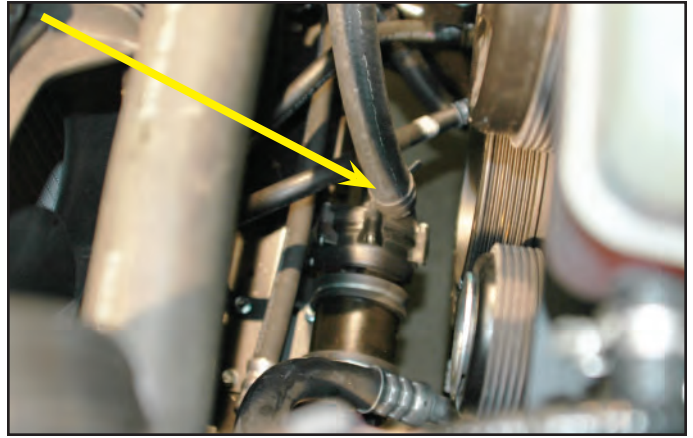

154. Cut a 59" section of the supplied 3/4" hose connect and clamp one end to the upper heat exchanger barb using the provided clamp. Follow the first hose through the hole into the engine compartment

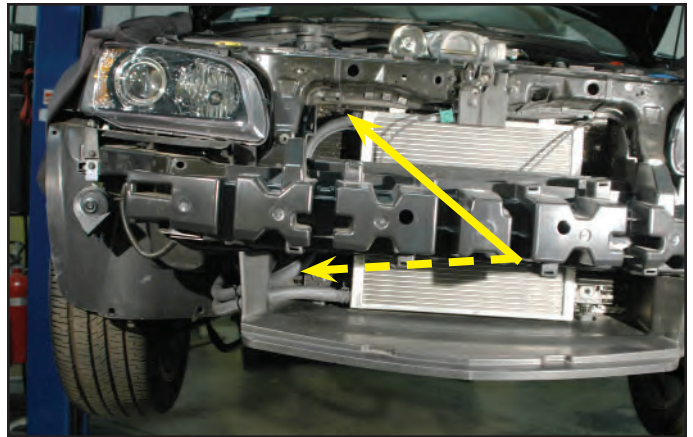

155. Clamp the free end of this hose onto the supercharger intercooler inlet barb using the provided clamp.



156. Cover hoses passing through plastic cowl with sections of the supplied split loom to avoid chafing and wear.

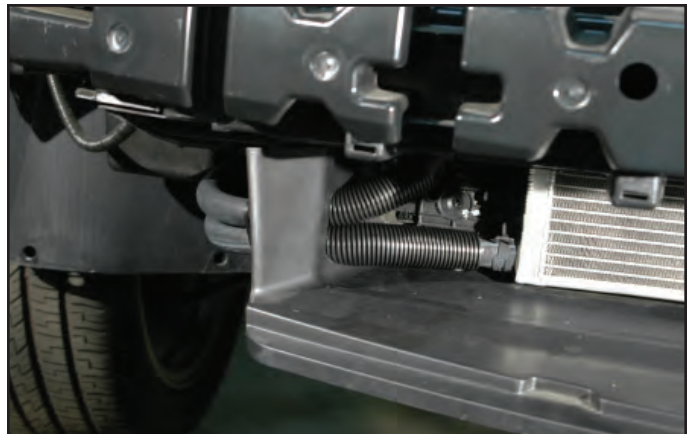

157. Cut 31" of the remaining  $\frac{3}{4}$ " hose and connect one end to the intercooler pump inlet barb using the supplied clamps.

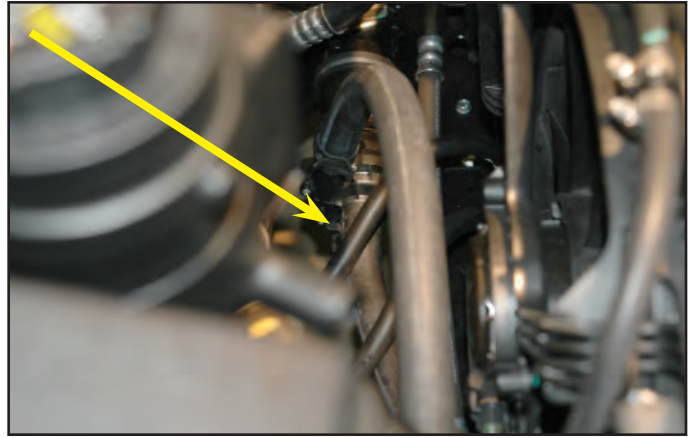

158. Route the hose from the last step to the intercooler reservoir and connect to the hose barb as shown using the supplied worm gear clamp.



159. Cut an 8" section of the  $\frac{3}{4}$ " hose and connect between the intercooler reservoir and the supercharger intercooler hose barb as shown. Clamp with the supplied hose clamps. Make sure you use a supplied worm gear clamp on the reservoir.

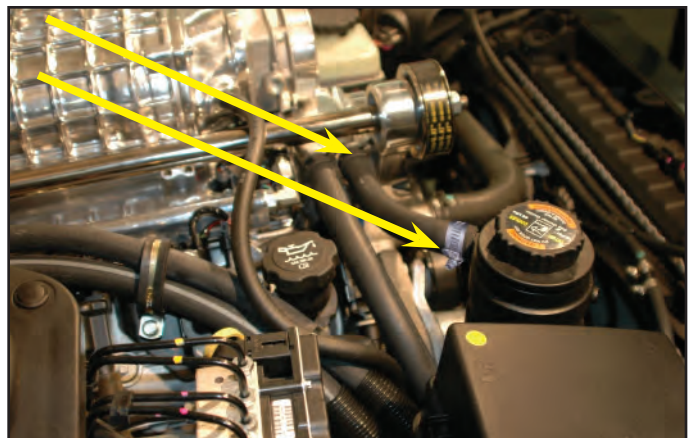

160. Use the supplied zip ties to anchor hose bundles, and sections of split loom to protect hoses from chafing edges.

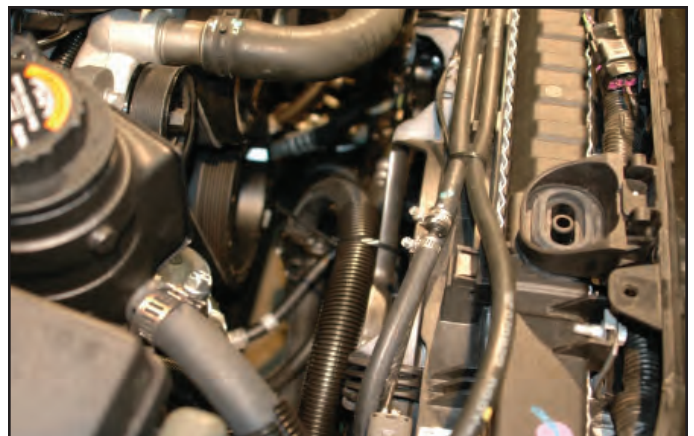

161. Remove the fuse box cover.



162. Remove the HVAC ignition fuse (slot F-37). Verify by fuse name, slot could vary!



163. Slip the supplied fuse tap over one leg of the OEM 10Amp fuse from the last step.

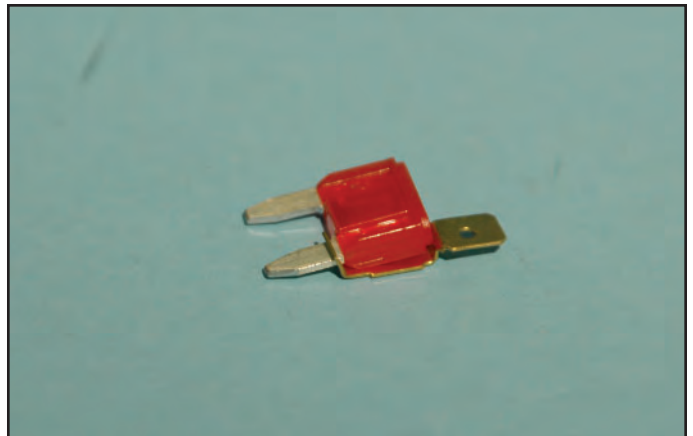

164. Insert fuse with fuse tap back into slot F-37, or the slot you removed it from.



165. Insert the supplied fuse into the supplied wire bundle.

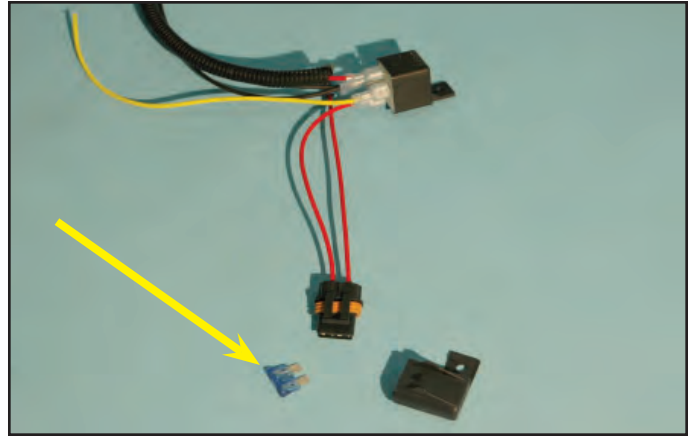

166. Zip tie relay to wire bundle adjacent to the coolant reservoir fill cap.



167. Route the intercooler control plug wires down along the hoses, zip tie as handy and plug into the intercooler pump receptacle.

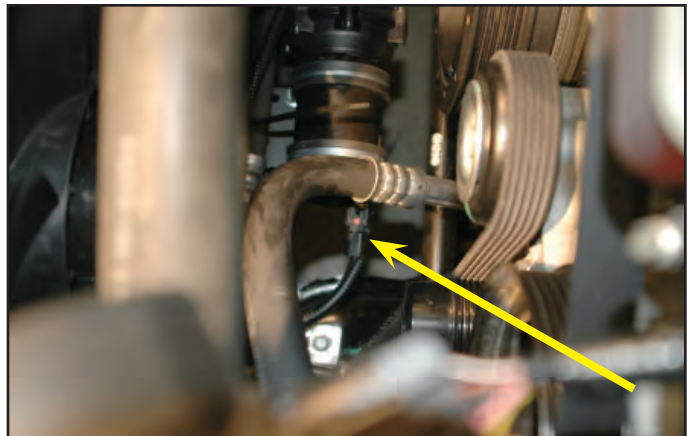

168. Shorten the black lead about 12" and attach the new eyelet end supplied.



169. Use a 13mm wrench to remove the fuse mount bracket bolt. Re-attach the bolt incorporating and grounding the black lead wire from the last step.



170. Remove the hot lead nut from the front of the fuse box with a 13mm wrench. Add the new hot lead wire and replace the nut.



171. Drill a 1/8" diameter hole for the new intercooler pump wire to route to the fuse-with-fuse-tap in slot F-37 (or where the HVAC Ign fuse was removed). Thread the yellow wire through the new hole, after which attach the supplied spade end connector.

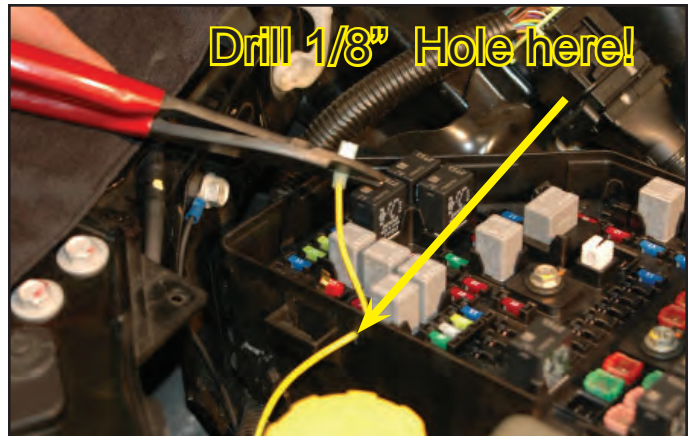

172. Plug the new yellow wire connector onto the HVAC Ign fuse tap in slot F-37 (or wherever you installed it).



173. Replace the fuse box cover.



174. Remove the inlet coupling from the inlet air tube and install it on the throat of the throttle body.



175. Connect the air inlet tube to the air-box at the bellows end.



176. Connect the other end of the inlet tube to the supercharger inlet. Tighten all clamps.



177. Connect the other end of the hose installed in step 135 to the barb on the air tube near the throttle body.



178. Re-install the factory plastic “splash shield” using the stock six push pins and existing mounting holes. If you removed it (step 35) replace the 5mph plastic bumper by pressing it into place

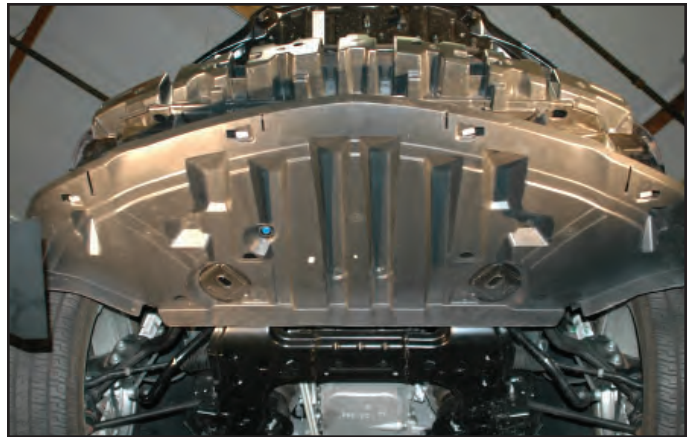

179. Re-install the front end fascia using the stock hardware (two bolts, and two push pins) on the top surface.



180. In front of the passenger side wheel well, plug the lights back into the connector. This was disconnected in step 30.

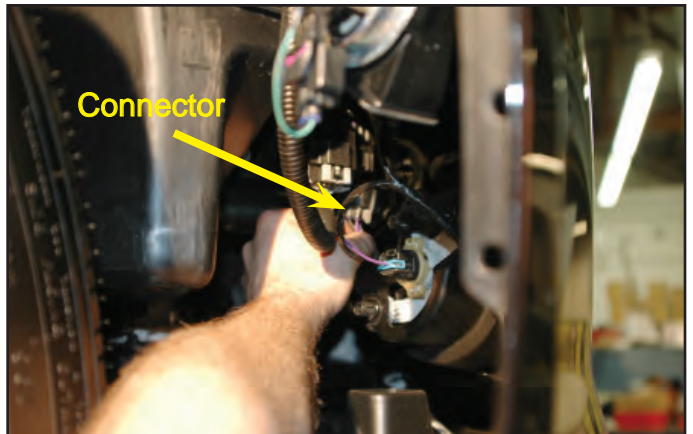

181. Bolt the fascia to the fender with the two fasteners on each side and use the factory push-pins to attach at all points (four each side). If you removed the fender well in step 28, then reattach at this time reversing the procedure.

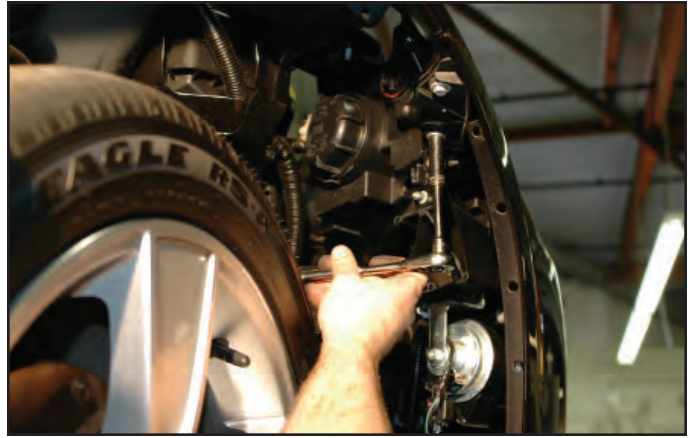

182. Use the four remaining bolts to bolt the fascia through the "splash shield".



183. Re-attach the battery lead cables, and replace the battery cover panel access door.



**Make sure that you have followed step #1 in this manual to load the proper supercharger calibration to your vehicle's ECM.**



184. Verify that your coolant drain is tightened and refill the coolant reservoir, topping off as necessary with a GM approved engine coolant mixture only.





185. Fill the intercooler reservoir with a GM approved engine coolant mixture only.



186. Attach the Vacuum Routing Diagram, Intercooler/Belt routing information and Premium Fuel stickers on the radiator shroud.

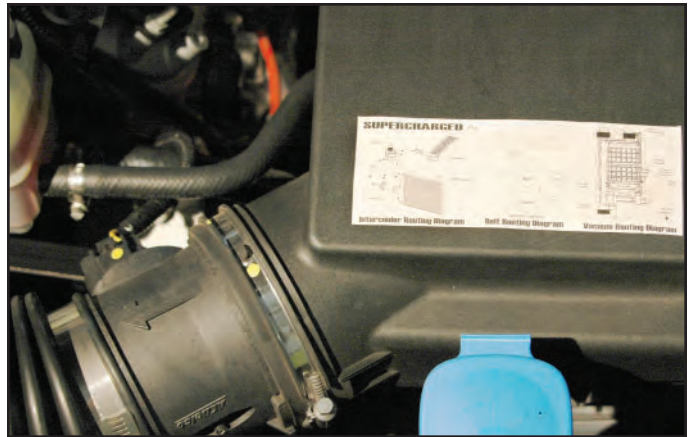

187. Start the vehicle for five seconds and shut off, once again check for fuel leaks and fan-supercharger belt alignment. Check radiator and intercooler reservoir levels.



188. Test-drive the vehicle for the first few miles under normal driving conditions (**Do not perform any wide open throttle runs**). Listen for any noises, vibrations, engine misfire or anything that does not seem normal. The supercharger does have a slight whining noise under boost conditions, which is normal.

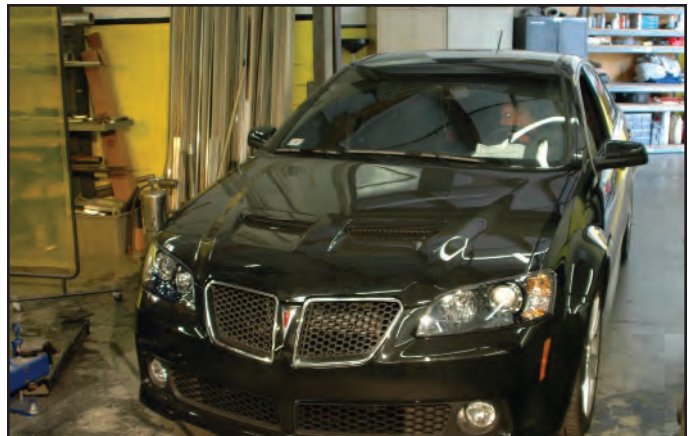

189. Re-check the intercooler reservoir coolant level regularly over the first 1000 miles, top level off as needed.



190. After the initial test drive gradually work the vehicle to wide open throttle runs, listen for any engine detonation (pinging). If engine detonation is present let up on the throttle immediately. Most detonation causes are low octane gasoline still in the tank. **Premium gasoline fuel (91 octane or better) must be used! It is NOT compatible with E85.** Affix the Premium Fuel Only decal on the inside of the fuel fill door.



**After you finish your installation and road test your vehicle, please fill out the warranty registration. This can be found on our website.**

If you have questions about your vehicles performance, please check with your installation facility.

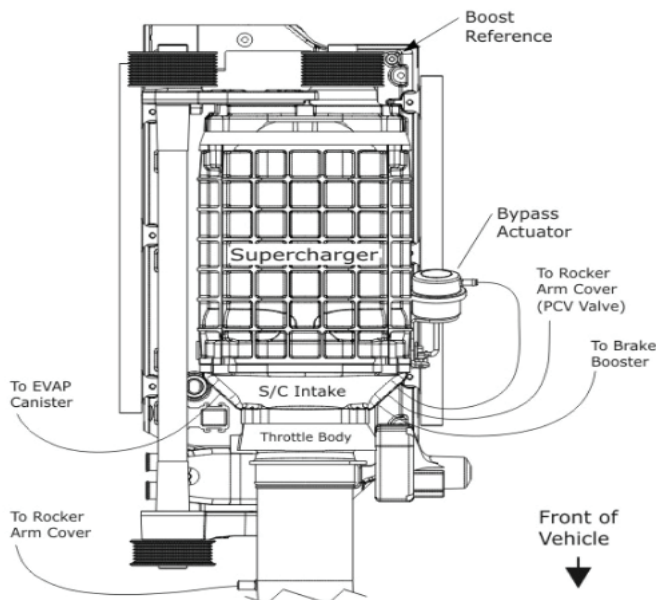

**Vacuum Routing Diagram**

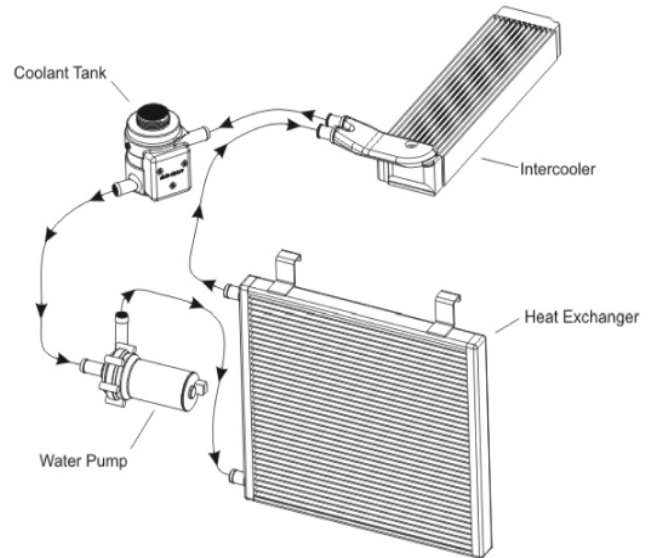

**Intercooler Routing Diagram**

## 2008 Belt Diagram

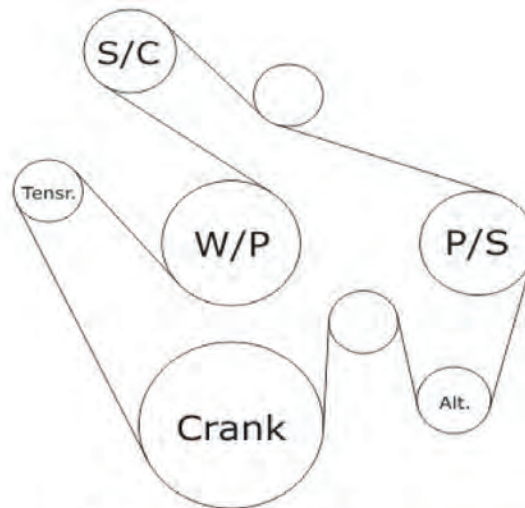

Belt P/N - 5061025

## Belt Routing Diagram

## 2009 Belt Diagram

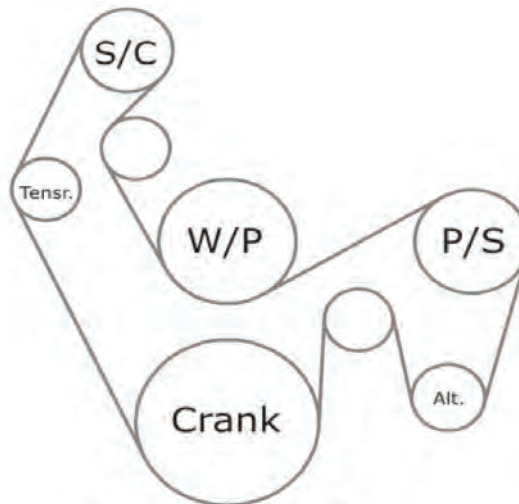

Belt P/N - K060878

## Belt Routing Diagram

The diagrams above show the variances between the 2008 and 2009.5 model year in respect to a change in the water-pump (see steps 57-58). Verify your belt specifications and diagram with your model.



If you have questions about your vehicles performance, please check with your installation facility.

**This supercharger system requires the use of only premium gasoline fuel, 91 octane or better. It is NOT compatible with E85, Ethanol, Flex Fuels.**

**NOTE: Your supercharger system is sensitive to corrosion. You must use the vehicle manufacturer specified coolant mixture in the intercooler system as well as your radiator.**

Please enjoy your “Magna Charged”  
performance responsibly!

**MAGNUSON**  
*SUPERCHARGERS*