



Roxor Self-Canceling Turn Signal System

Thank you for purchasing XTC Power Products Automatic Self-Canceling Turn Signal System. Our Easy Install Turn Signal System is unique from the other kits on the market. This kit is from our Plug & Play™ product line, no wires to cut, no crimping with only power, ground and plugs into the OEM Tail Light Harness, utilizing the brake lights as Brake and Turn Signals.

Please read the instructions fully and familiarize yourself with the components before starting the install.

ROXOR Automatic Self-Canceling Turn Signal System

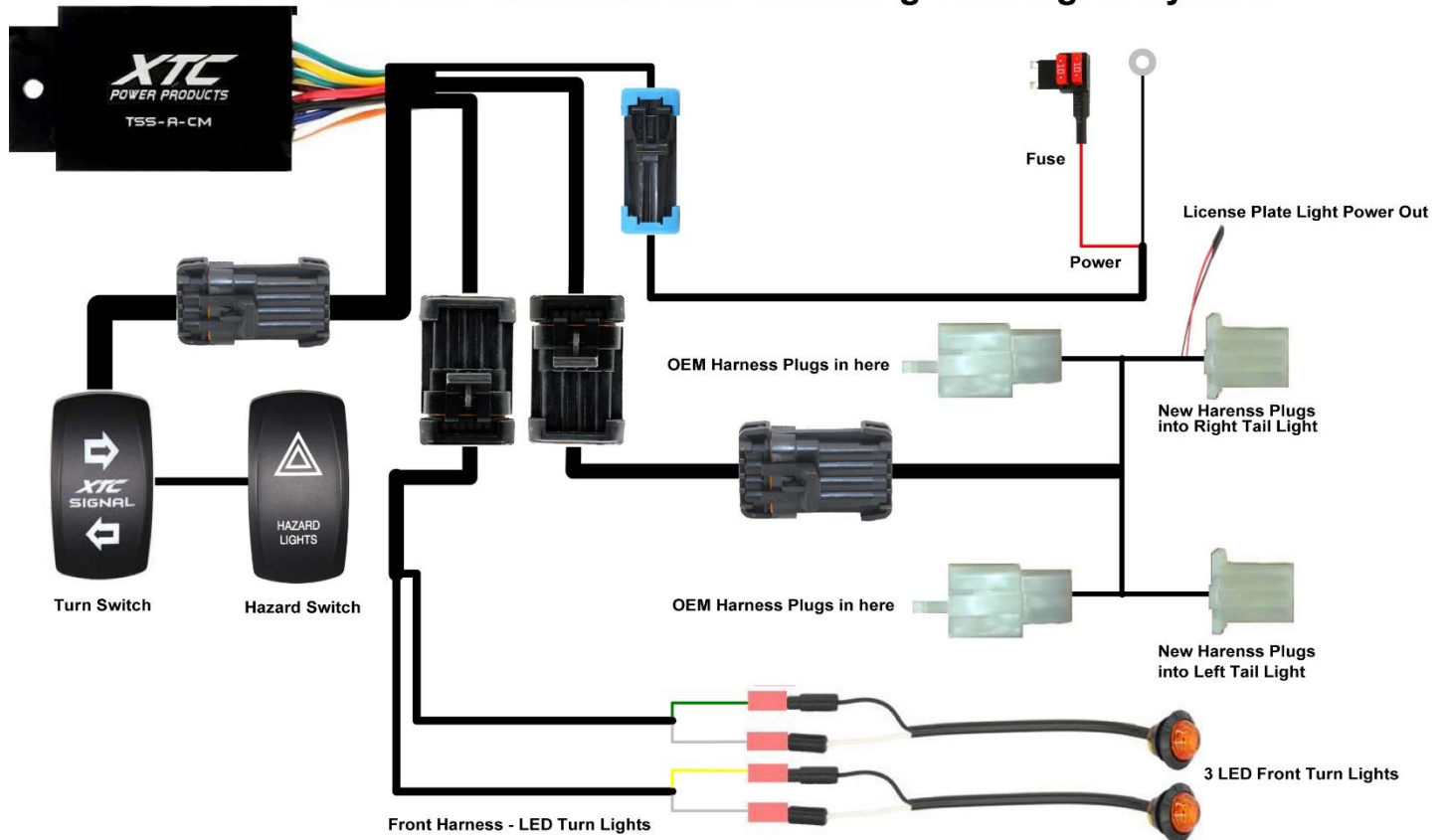

Not to Scale
Copyright © 2019 XTC Motorsports LLC All Rights Reserved

Dielectric Grease – We have included a packet of grease. Just like the OEM we recommend using Dielectric Grease on all switch terminals and on the white non-sealed factory connectors on the rear tail lights, this helps keep the water out and it also reduces corrosion and increases reliability! You do not need to put the grease on our four pin **SEALED** Connectors. Open the grease and put on the switch terminals and the connector terminals.

1. Take the rear Harness with the white connectors on it and plug the one with the Yellow wire into the driver's side rear tail light in-line.

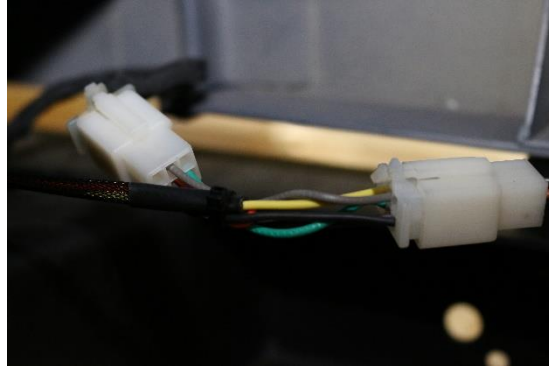
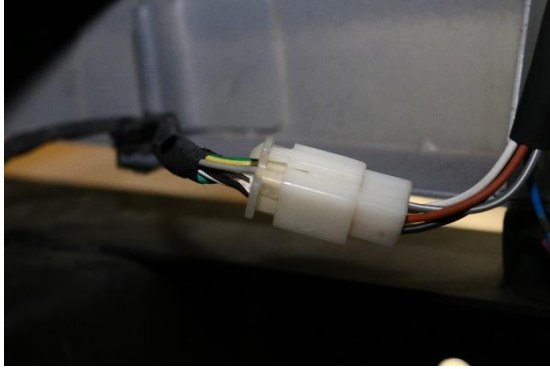

2. Run the other side of the Harness through the bumper over to the passenger side and plug in-line. Secure with cable ties.

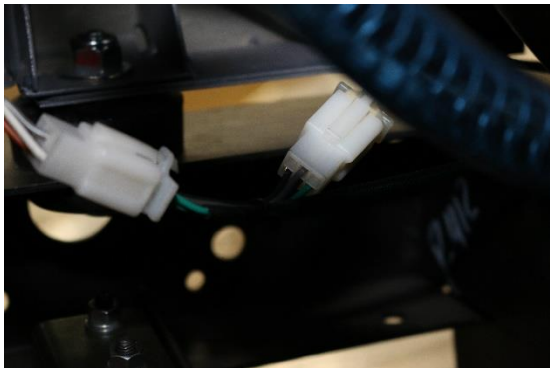

3. Unroll the long rear cable, plug it into the rear harness just installed. Run the cable under the chassis. Remove two Rubber Grommets and using a razor blade cut an x in the center of each one and run the Rear Harness connector through one of the grommets and reinstall in one of the holes. Secure the harness using the supplied Cable Ties.

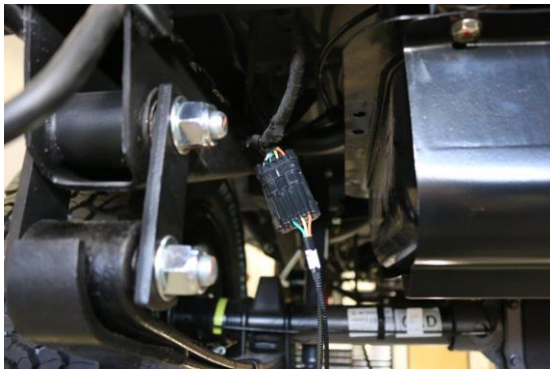

4. Mount the Control Module as shown below under the grommets using self-tapping screw provided and Plug the Rear Harness in.



5. **WARNING! Verify that there is clearance where you want to mount the front LED lights before drilling the holes.** Install Front LED Turn Lights – The front LED Turn Indicators can be mounted with the rubber grommet or without. If the grommet is **not** being used drill 5/8" holes. If the grommet is being used drill 3/4" holes. Remove and install the rubber grommet from the LED into the hole if being used, if not attach using the 3M double sticky tape. Insert LED into the hole with the Top marking up. **NOTE:** the TOP marking is on the front of the LED lens. The Lights may be mounted anywhere on the front of the car, for the sample we chose the grille keeping in line with the Jeep look.



6. Lay the front small light harness out in the front under the hood, run the connector with the green wire to right side LED and run the connector with the yellow wire to the left side. Run the 4-way connector through the second grommet that was cut and plug-in to the Control Module. Insert bullet connectors into LED connectors. **NOTE: The Black LED wire is positive and goes to the yellow and green wires, they will not work if reversed, white is ground. Secure the Harness using the provided cable ties.**
7. Install Dash Switches. Remove two switch blanks, run the first switch harness through the opening, apply Dielectric Grease on the switch terminals and plug the Turn switch in and push into dash, do the same for the Hazard Switch. **Note: We found it somewhat difficult to remove the switch blanks, two tabs on the top and two tabs on the bottom need to be pushed to get them out, since we were not going to reuse them we ended up cutting two of the tabs off to make it easier to remove.**

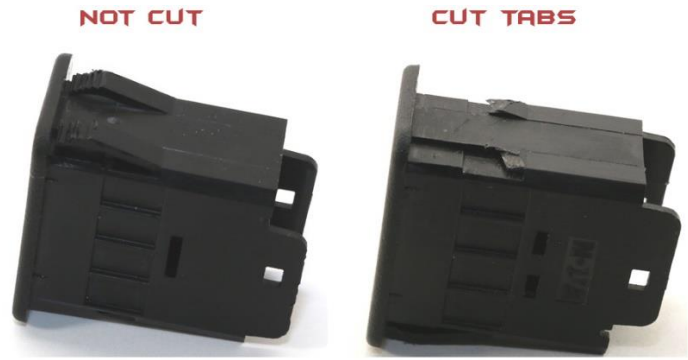
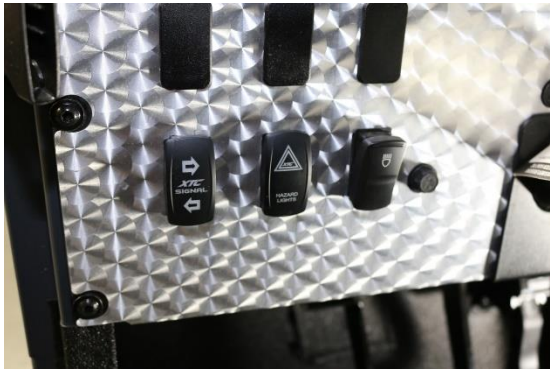

8. Plug the 2-Way power Connector into the Control Module. Run the other end with the fuse over to the fuse block on the passenger side under the dash. To make it easy to work and see the fuses there is a tab on the right side that can be pushed in to release the fuse box, more information can be found in your Instruction Book. Also, it can be removed by removing the 2 screws at the bottom of the bracket, one screw must be removed later to attach the ground wire.

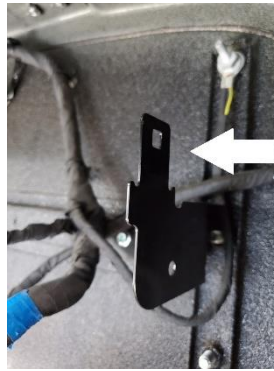

9. Remove the fuse cover and find the 10-amp fuse # F28 as shown and remove.

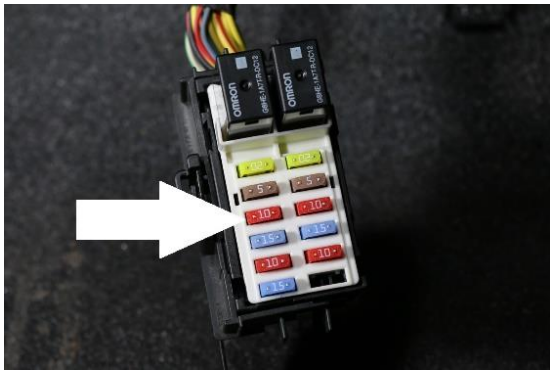

10. Plug the fuse adapter into F28 as shown below.

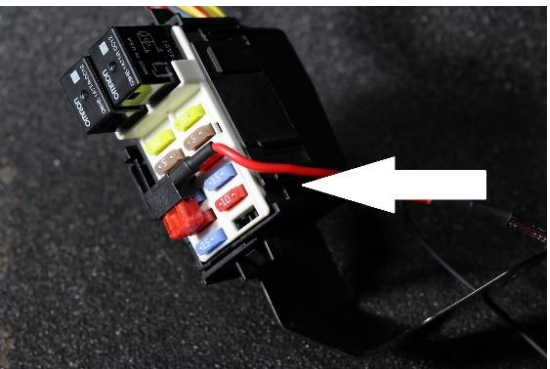

11. Run the power wire down the slot on the right side and reinstall the fuse cover. Remount the fuse box and using the Fuse Mounting screw attach the black ground wire as shown.

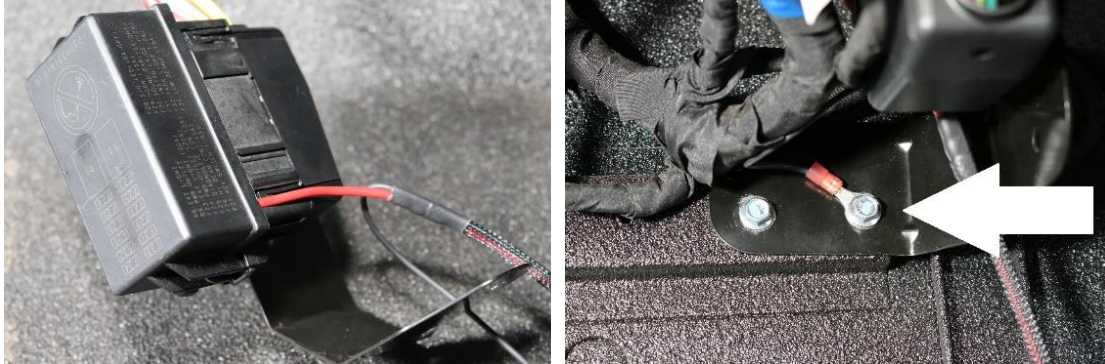

12. The System uses momentary switches to activate. Press the Right or Left Actuator accordingly. You can cancel the signal at any time by pushing the activated switch a second time or it will cancel as follows:
- Press 1 Second for Lane Change, will stay on approx. 8 Seconds / 10 Flashes
 - Press 2 Seconds for Slowing to Turn Corners, will stay on approx. 20 Seconds / 30 Flashes
 - Press 5 Seconds for Traffic Lights when stopping and waiting, will stay on approx. 75 Seconds / 110 Flashes

The Systems Automatic Self-Cancelling may be overridden/Shut Off at any time by pushing the activated switch.
Hazard Lights - press to activate and press again to deactivate, it does not self-cancel.

13. Using the provided Cable Tie's secure the harness completely. Reinstall removed parts
Optional - The Tan wire next to the Turn Switch is for an optional Dash Indicator. When the ATS is activated it will flash 12 VDC that can be attached to an Optional Dash Mounted LED Light.

We can be reached by email at support@xtcpowerproducts.com

XTC Power Products
A Division of XTC Motorsports LLC
925 N McQueen RD. #101
Gilbert AZ 85233
480-558-8588
www.xtcpowerproducts.com

*Disclaimer: This kit is intended for off road use only and XTC Motorsports claims no responsibility for it use. It is up to the purchaser to make sure it complies with all Federal, State and Local laws.

R5