

- English

ATOMSTACK

ATOMSTACK MR 20

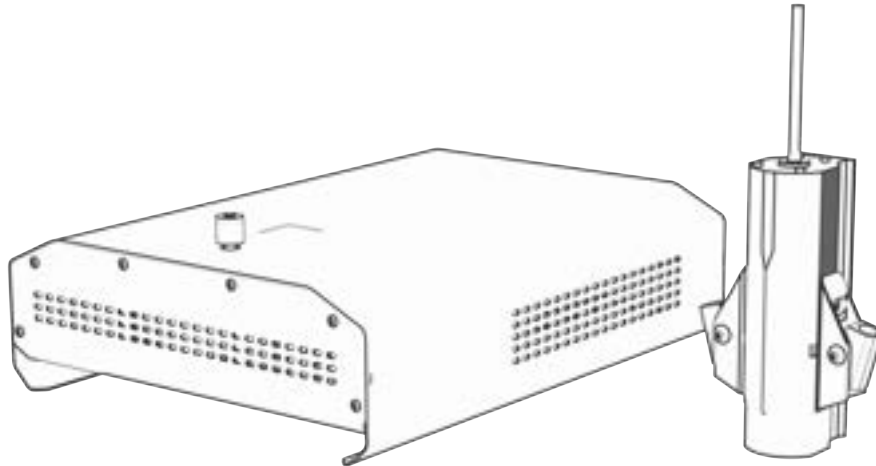

F03-0198-0AA1 Version: A



Laser Engraver

Note: The picture is for reference only, the actual product shall prevail.
For more information, please scan the QR code

Packing List

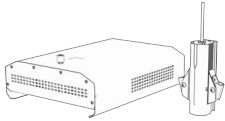

Laser module



TYPE-C data cable



Laser signal cable



Power cable



Z-axis component



Laser slider



Knurled screws 2PCS (M4*12)

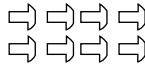

Screws 8PCS (M4X6)



Screws 2PCS (M5X8)

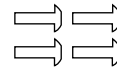

Screws 4PCS (M4X10)

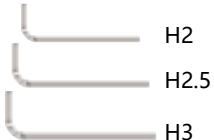

Allen wrench



Control box



T-nut 2PCS

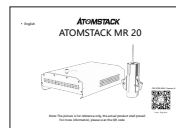

Instruction manual

Step 1 Connect the Z-Axis and Slider to the Machine

Option 1 Connect the Z-axis and slider to the machine from the back.

1

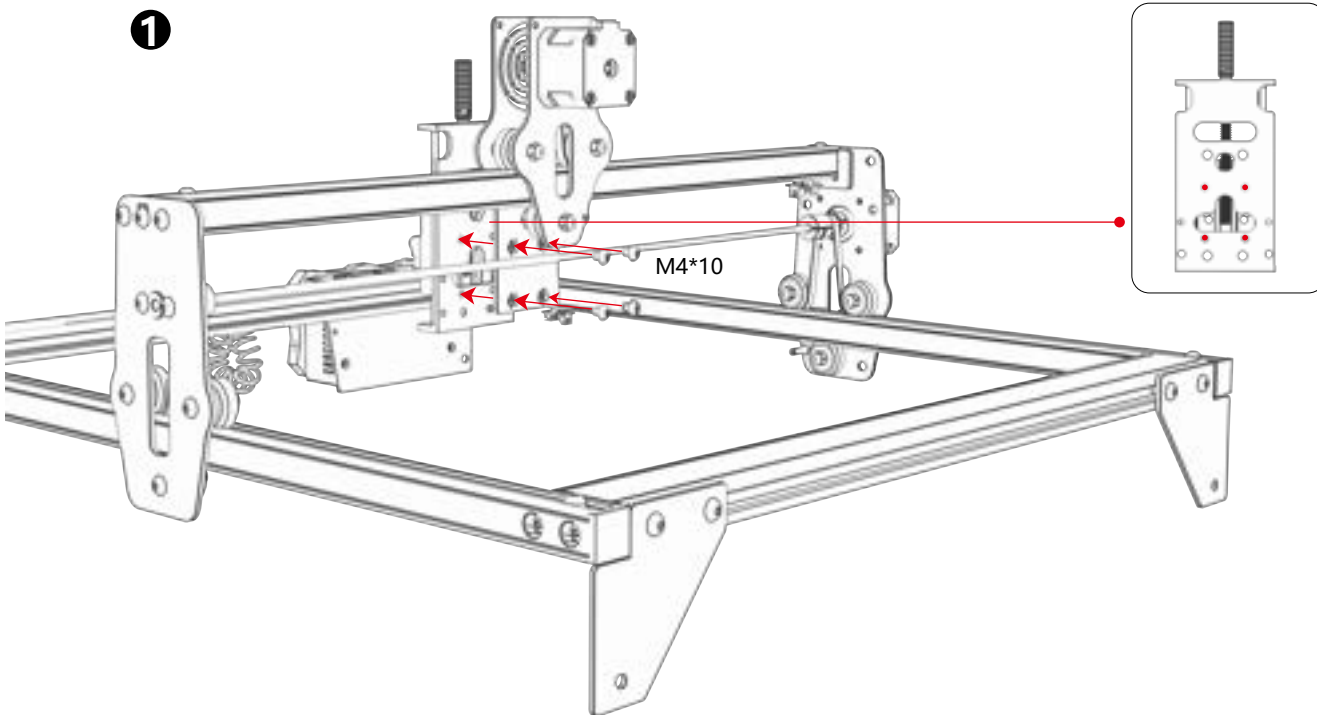

2

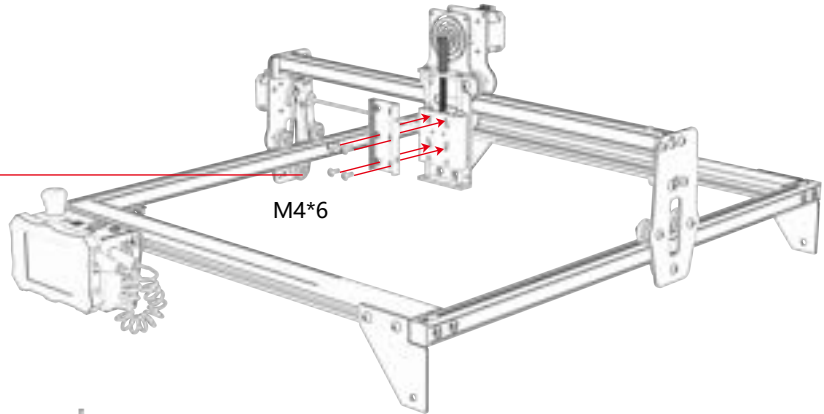
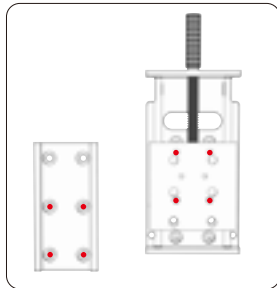

M4*6

3

Precautions:

Do not fold the fiber optic cable behind the laser.

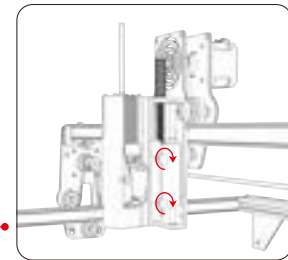
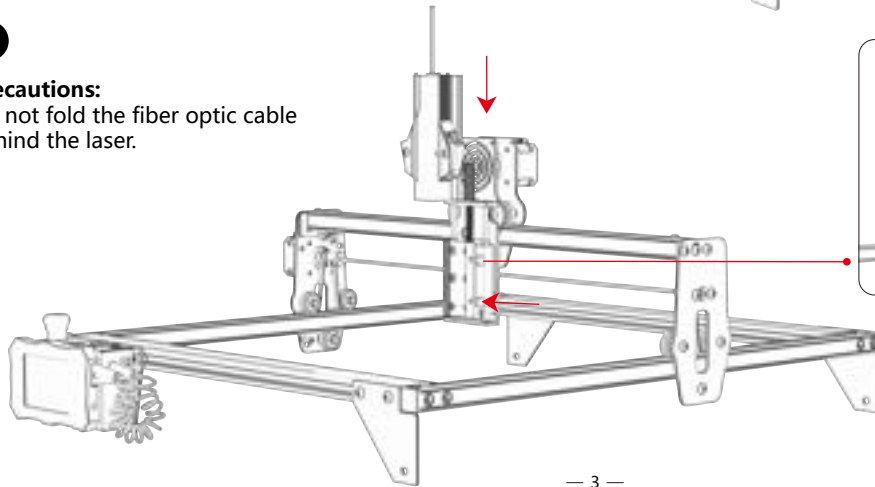

Tighten the screws

Option 2 Connect the Z-axis and slider to the machine from the front.

1

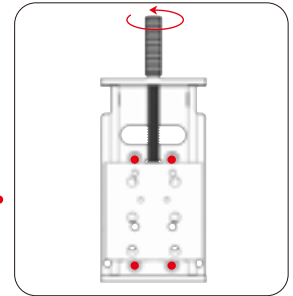
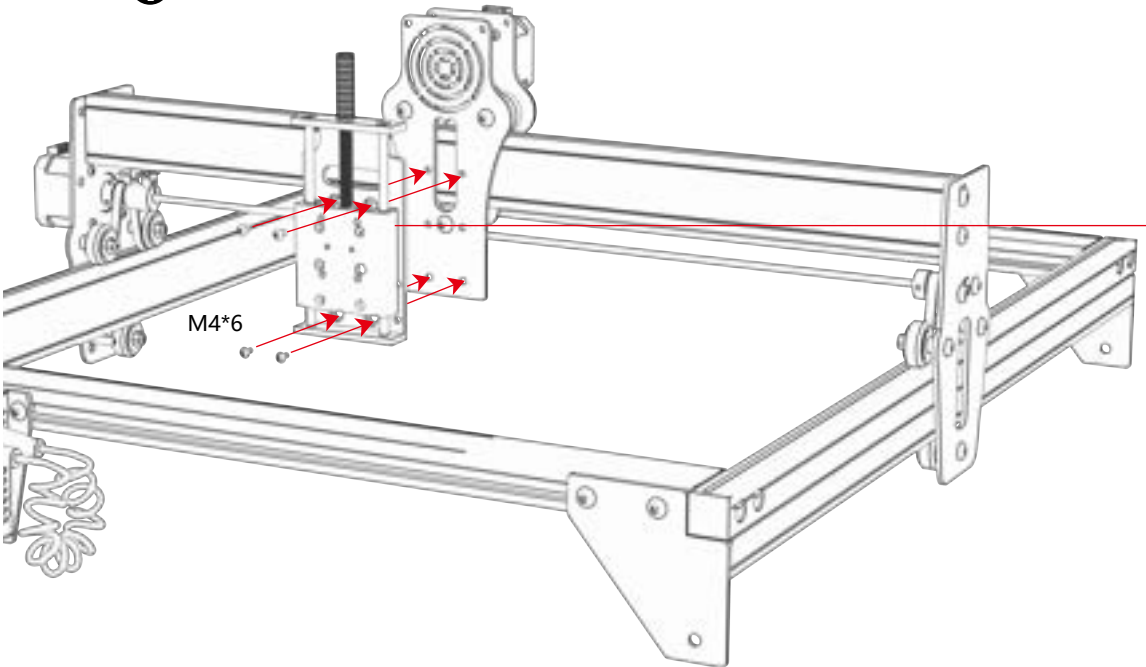

Rotate the handle to move the slider.

2

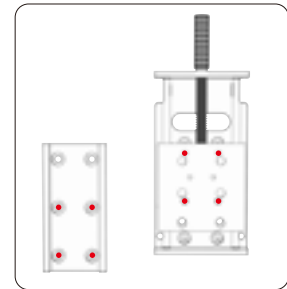
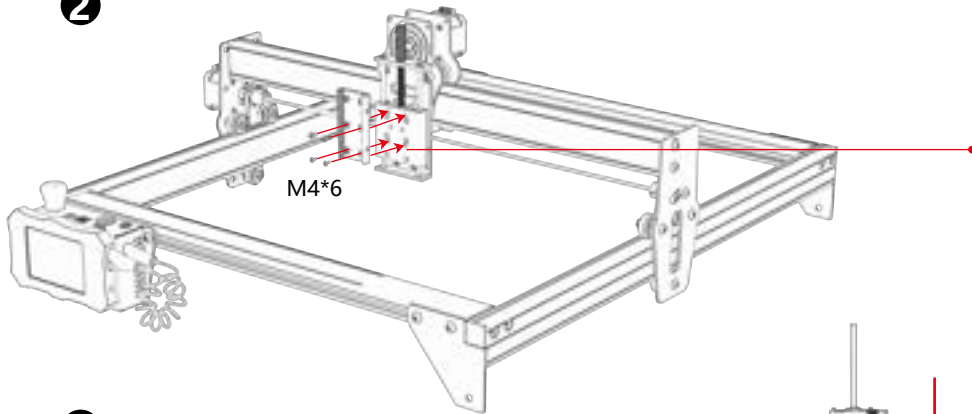

3

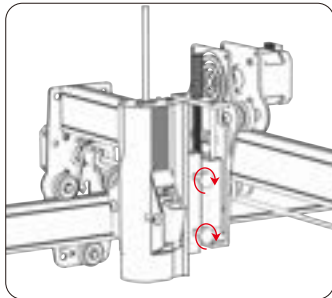

Tighten the screws

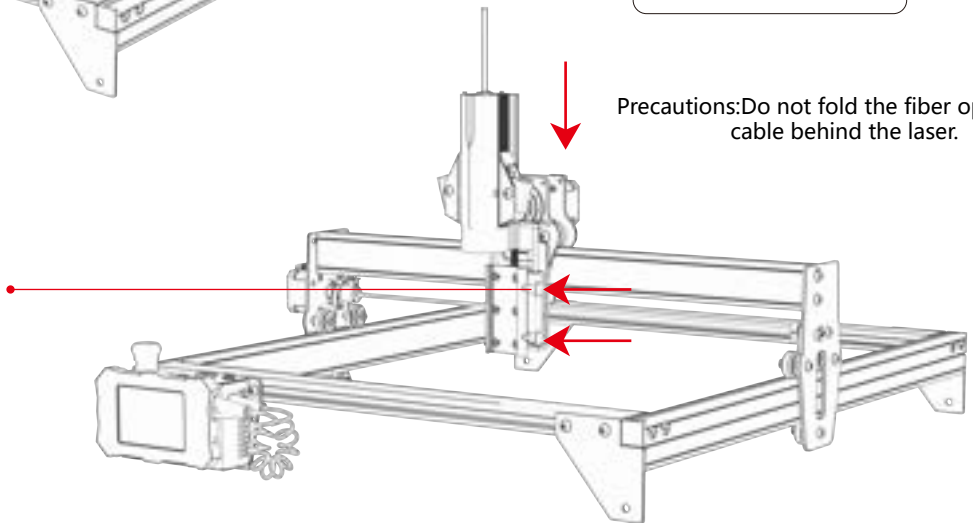

Option 3 This type of Z-axis does not require replacement and can be inserted directly into the laser head.

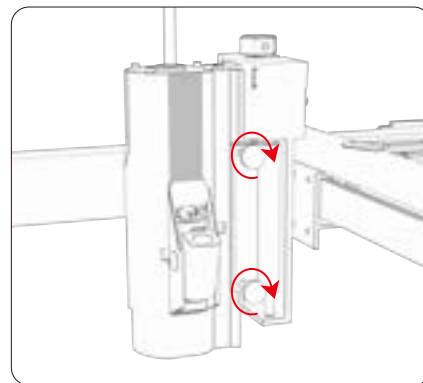
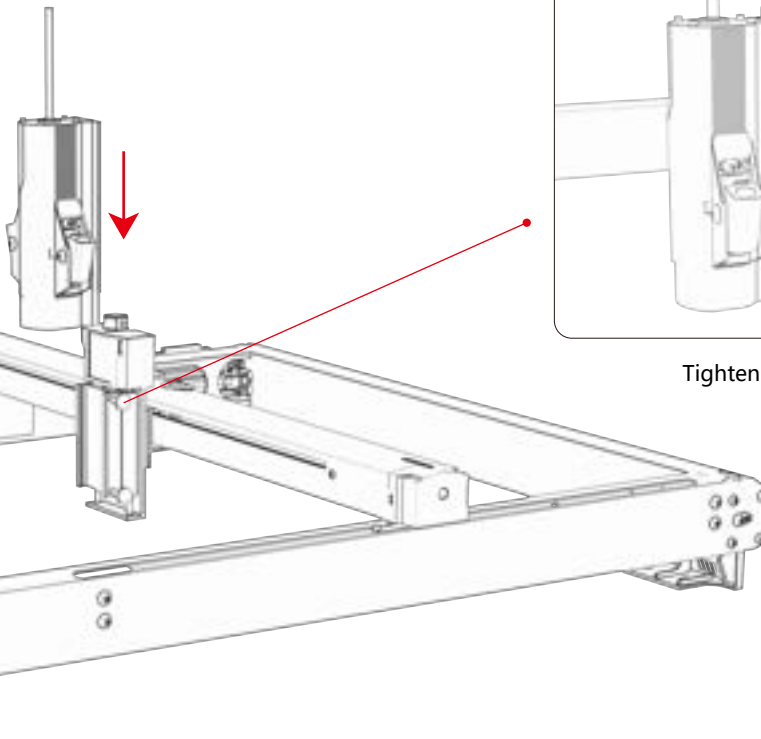
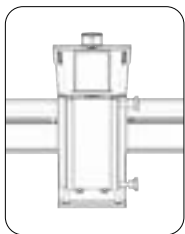

Tighten the screws

Step 2 Replace the control box

Method 1 The trial installation control box is paired with the hole position before the type, and the control box is directly installed.

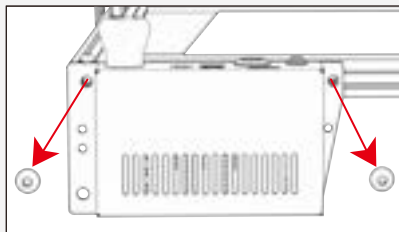

Remove the original control box and cable

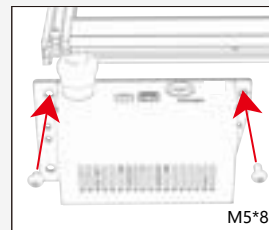

Install the control box in the manifold

Method 2 The trial control box is not matched with the hole position in front of the type, and it is necessary to wear a T-nut and lock two M5*8 screws.

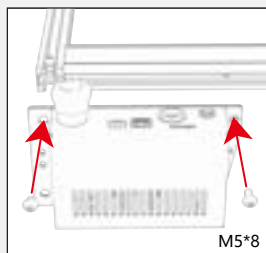

Install the control box in the manifold

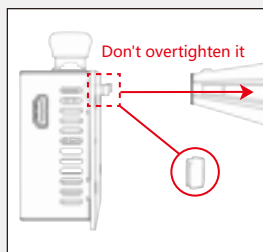

Install the T-nut

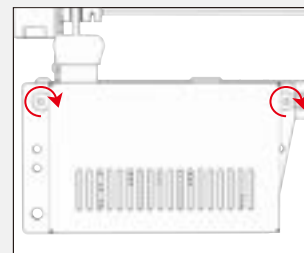

Tighten the screws

Step 3 Connecting cables

Control line
Laser signal cable
Type-C data cable

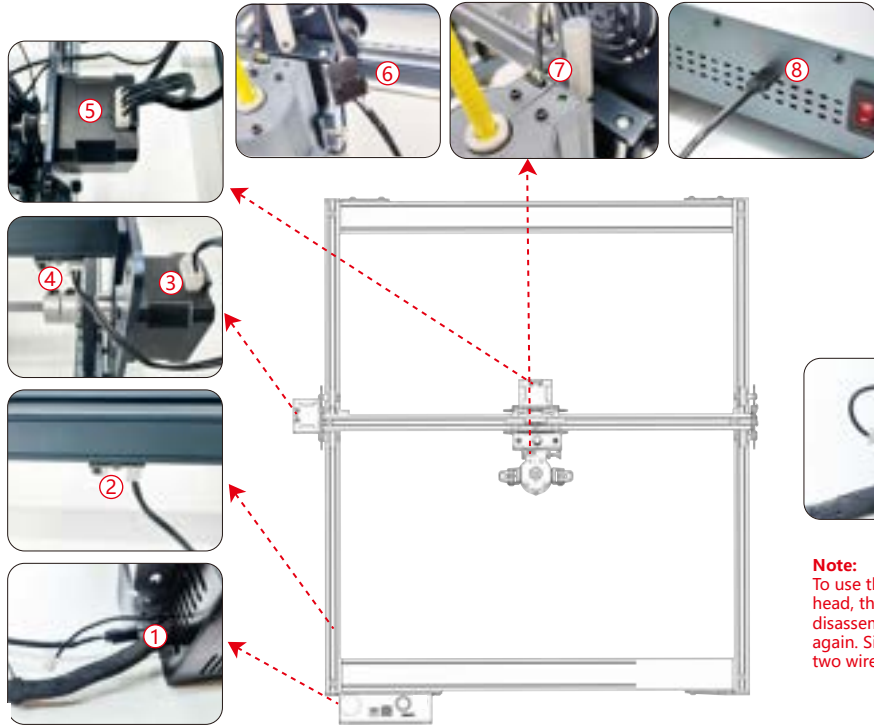
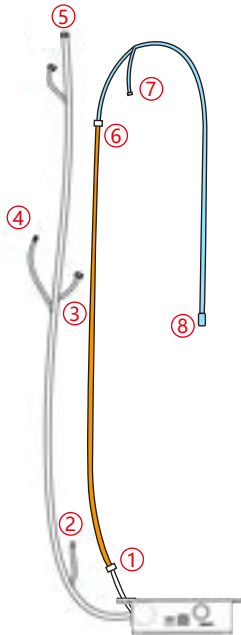

Note:
To use the original laser head, there is no need to disassemble the control box again. Simply connect these two wires together.

Step 4 Test Process - Power On

1. Turn on the machine power switch



First turn on the power switch of the machine, and then turn on the switch of the fiber laser control box to avoid the probability of random emission for about 2 seconds after power-up.

2. Focus Adjustment

- 1) Position the test material on the machine.
- 2) Observe whether the red light spots at the left and right ends of the laser head overlap. If not, adjust the height by rotating the knob on the Z-axis to make the two spots coincide.



3.Laser Frequency Adjustment

The frequency of the control box can be adjusted from 30kHz to 60kHz. Refer to the parameter table for adjustments.(pp. 16-19)



Step 5 Testing Process - Use on PC

1) When using Lightburn for online or offline engraving of images and pattern filling, it is recommended to enable overscanning for better engraving results.

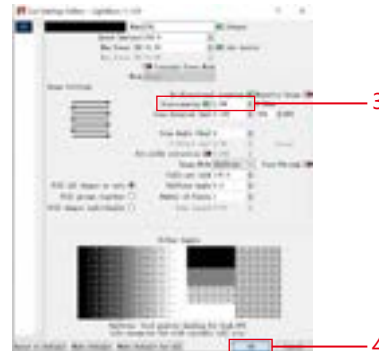
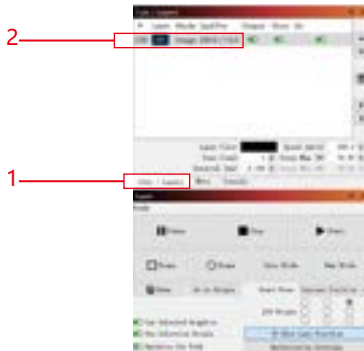

2) Refer to the machine's user manual for instructions on how to use Lightburn. The only difference is in the framing process. For framing in Lightburn, select "Move" > "Power" and set it to 0. You can monitor the framing process through the red light indicator.

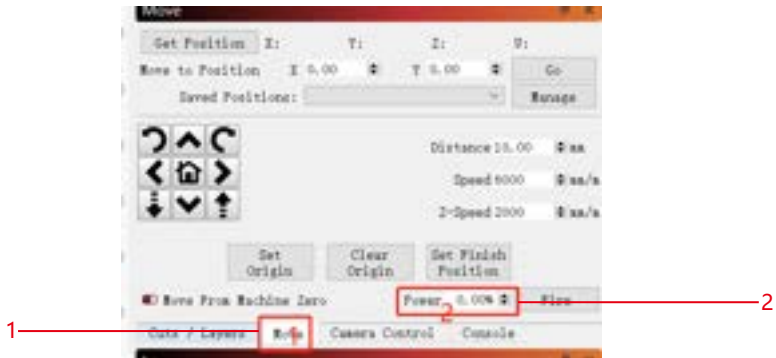

3) Refer to the machine's user manual for instructions on how to use LaserGRBL. The only difference is in the framing process. When performing framing in LaserGRBL, the framing energy needs to be changed to 0.

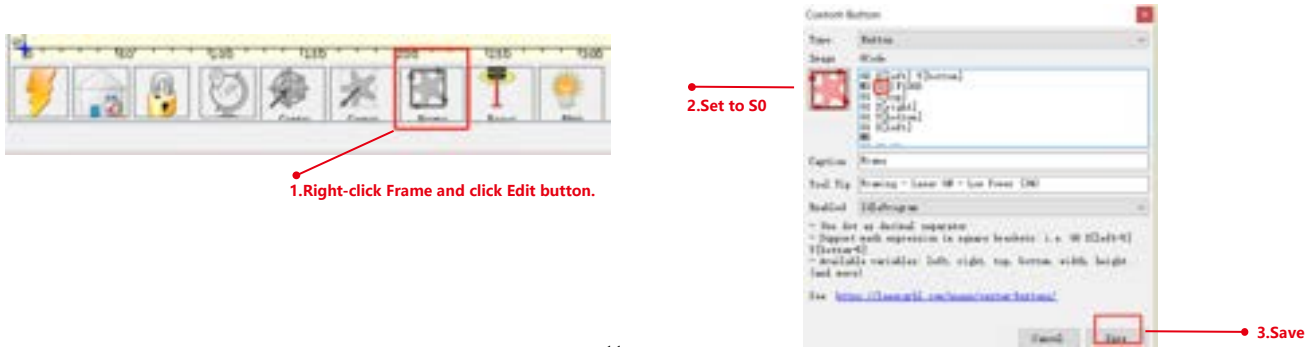

Step 6 Testing Process - Offline Use of K1 Machine

1) When using a blue laser offline with lightburn, click on "Edit" and select "Machine Settings." Change the PWM min value (\$35) from 0 to 1. Note that \$35 of FL20 should be set to 0 and that of blue laser should be set to 1.



2) When using a blue laser offline with GRBL, click on "Grbl" and select "Grbl Configuration." Change the \$35 value from 0 to 1. Note that \$35 of FL20 should be set to 0 and that of blue laser should be set to 1.

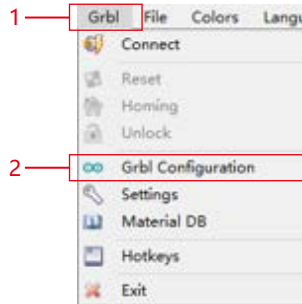

Step 7 Testing Process - Offline Use of A40 Pro Machine

1) When using a blue laser offline with lightburn, click on "Edit" and select "Machine Settings." Change the PWM min value (\$35) from 0 to 1. Note that \$35 of FL20 should be set to 0 and that of blue laser should be set to 1.



2) When using a blue laser offline with GRBL, click on "Grbl" and select "Grbl Configuration." Change the \$35 value from 0 to 1. Note that \$35 of FL20 should be set to 0 and that of blue laser should be set to 1.

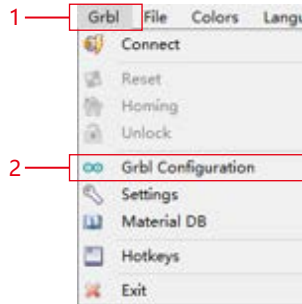

Step 8 Testing Process-Offline use without machine shipment

1) lightburn: When using a blue laser offline, click on "Edit" and select "Machine Settings." Change the PWM min value (\$60) from 0 to 1. Note that \$60 of FL20 should be set to 0 and that of blue laser should be set to 1.

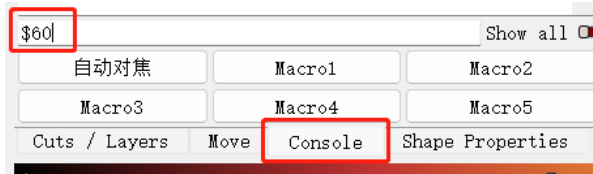

2) GRBL: When using a blue laser offline, click on "Grbl" and select "Grbl Configuration." Change the \$60 value from 0 to 1. Note that \$60 of FL20 should be set to 0 and that of blue laser should be set to 1.

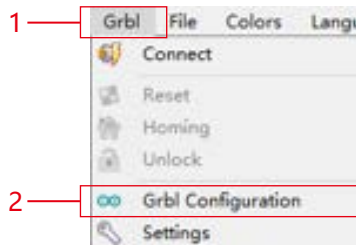

3. lightburn Engraving power settings : Power Max(%) > 10%, refer to the parameter table for specific values.

Please note: Engraving vector mode should be set to "M3 mode". Follow the steps below to operate: "Cuts / Layers" -> "Line" -> "Constant Power Mode".

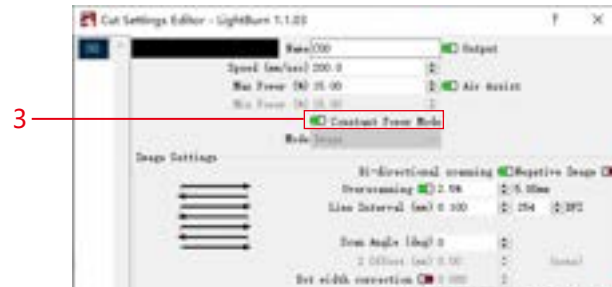

Step 9 FAQ

1) If the engraving or cutting effect is not satisfactory:

- a) Check if the laser is in the focal position.
- b) Check the cleanliness of the lens.

2) If there is a malfunction with the red light indicator and it is inconvenient to check the focal distance through overlapping red lights, you can adjust the focal distance through fixed focus method (distance from laser end face to the measured object: 96.1mm/94.1mm).

3) If there are no traces or uneven energy in the engraved vector lines:





- a) Check if the laser is in the focal position.
- b) Confirm if it is operating in M3 constant power mode.

Remark:

1.Our parameter list is only for the most widely used materials. Customers may need to try other uncommon materials by themselves, or they can contact us to apply for testing.









2.Line mode for vector lines requires M3 mode

Engraving Parameter for Common Material

Material	Engraving						Case illustration
	Quality	Speed (mm/m)	Max-Power	Frequency (KHz)	Image Mode	Needs to be blackened	
Copper	100	7000	800	30	Threshold	NO	
Iron	100	5000	800	30	Threshold	NO	
Natural color alumina	100	10000	800	30	Threshold	NO	
Coated alumina	100	7000	800	30	Threshold	NO	

Brushed Stainless Steel	100	5000	500	30	Threshold	NO	
Mirror Stainless Steel	100	6000	800	40	Threshold	NO	
Painted furniture	100	10000	600	30	Threshold	NO	
ABS	100	10000	400	30	Threshold	NO	
Plastic	100	15000	800	30	Threshold	NO	

Material	Engraving						Case illustration
	Quality	Speed (mm/m)	Max-Power	Frequency (KHz)	Image Mode	Needs to be blackened	
Leather	100	10000	700	30	Threshold	NO	
Acrylic	100	13000	700	30	Threshold	NO	
Rubber	100	6000	600	30	Threshold	NO	
Oil painting paper	100	12000	700	30	Threshold	NO	
Rock	100	15000	800	30	Threshold	NO	
Mirrors	100	12000	500	30	Threshold	YES	
Ceramic tile	100	5000	800	30	Threshold	YES	

Cutting Parameter for Common Material							
Material	Cutting						Case illustration
	Thickness (mm)	Speed (mm/m)	Max- Power	Frequency (KHz)	Number of passes	Needs to be blackened	
Rubber	2	1000	800	30	30	NO	
Aluminum business card	0.2	300	800	30	1	NO	
Stainless steel sheet	0.15	300	800	30	1	NO	
EVa Foam	8	1000	800	30	1	NO	
Leather	2	300	800	30	1	NO	
Copper	0.5	100	1000	30	50	NO	
Iron	0.5	100	1000	30	50	NO	
Aluminum business card	0.5	100	1000	30	50	NO	



Customer service:

For detailed warranty policy, please visit our official website: www.atomstack.com
For technical support and service, please email :support@atomstack3d.com

Manufacturer:

Shenzhen AtomStack Technologies Co.,Ltd

Address:

AB301,New Chabridge Industrial Park,No.3,Baolong 6th Rd.,Longgang
Dist,Shenzhen,Guangdong,china

Zip code: 518116

Scan QR code:

QR code reader/barcode scanner or any app with a scanner



- Deutsch

ATOMSTACK

ATOMSTACK MR 20

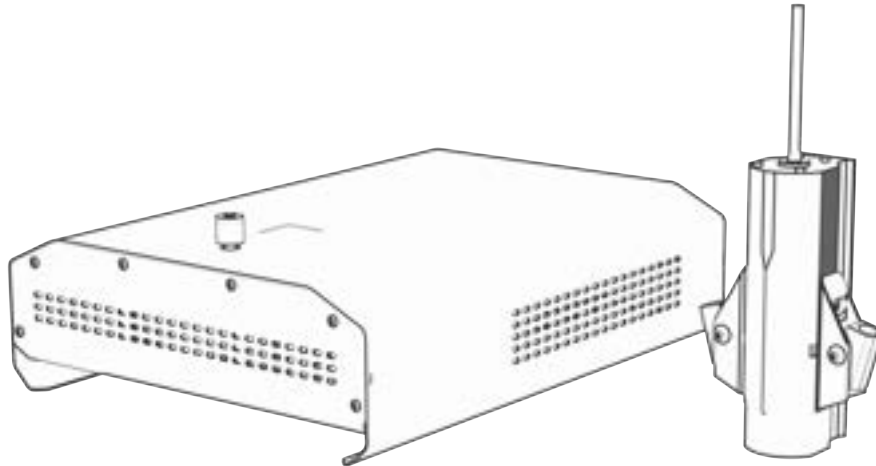

F03-0198-0AA1 Version: A



Laser Engraver

Hinweis: Das Bild dient nur als Referenz, das tatsächliche Produkt hat Vorrang.
Für weitere Informationen scannen Sie bitte den QR-Code

Packliste

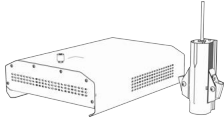

Laser-Modul



TYP-C Datenkabel



Laser-Signalkabel



Stromkabel



Komponente der Z-Achse



Laser-Schieberegler



Rändelschrauben 2 STK (M4*12)

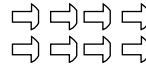

Schrauben 8 Stück (M4X6)



Schrauben 2 STK (M5X8)

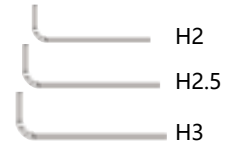

Allen wrench

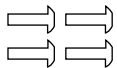

Schrauben 4STK (M4X10)



Schaltkasten



T-Mutter 2 STK



Bedienungsanleitung

Schritt 1 Verbinden Sie die Z-Achse und den Schieber mit der Maschine

Möglichkeit 1 Verbinden Sie die Z-Achse und den Schieber von hinten mit der Maschine.

1

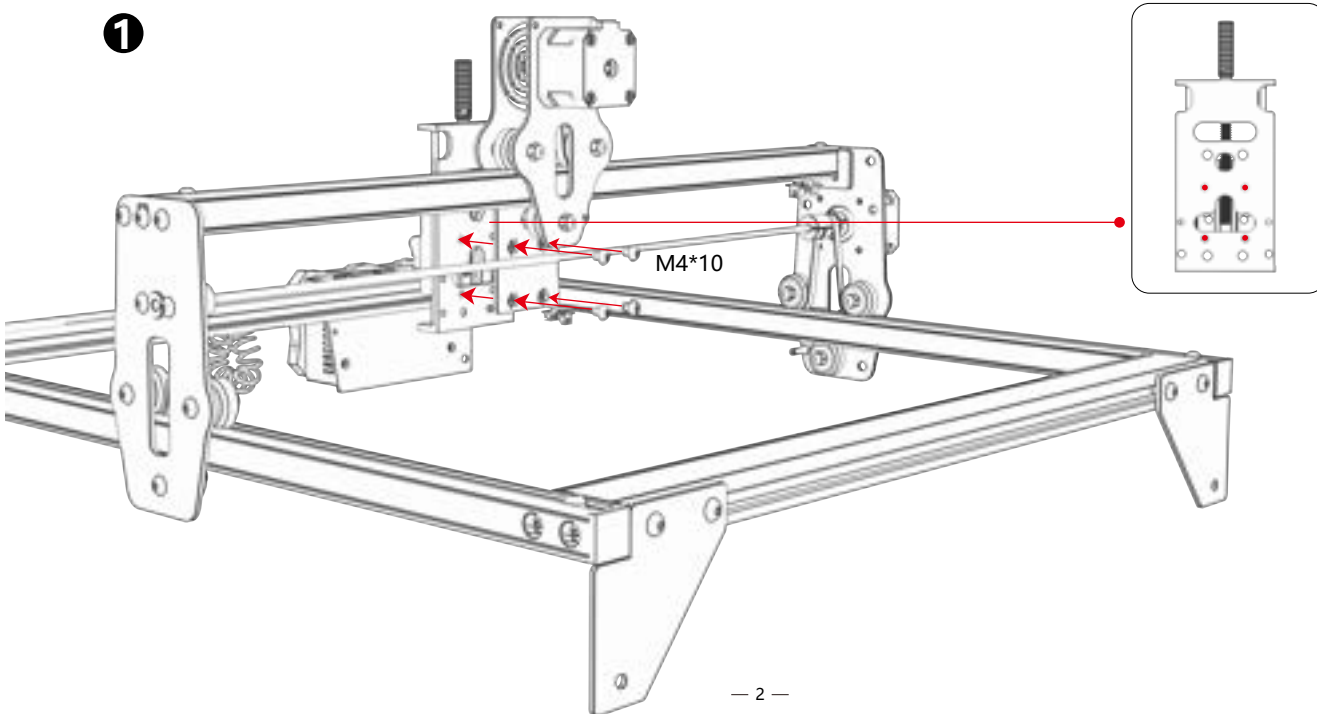

2

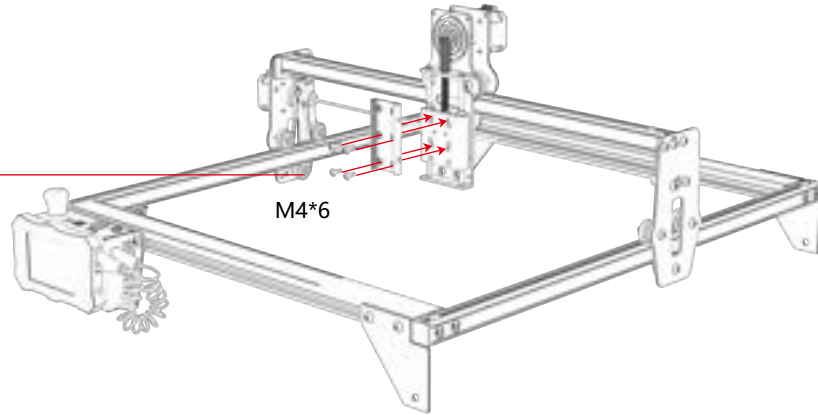
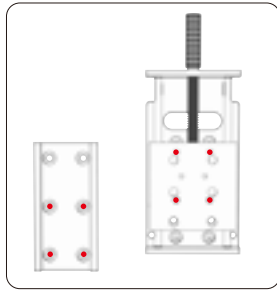

3

Vorsichtsmaßnahmen:
Falten Sie das Glasfaserkabel nicht
hinter dem Laser.

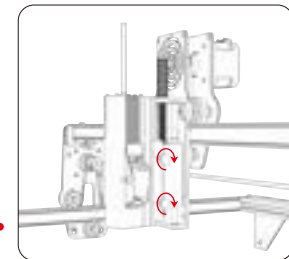
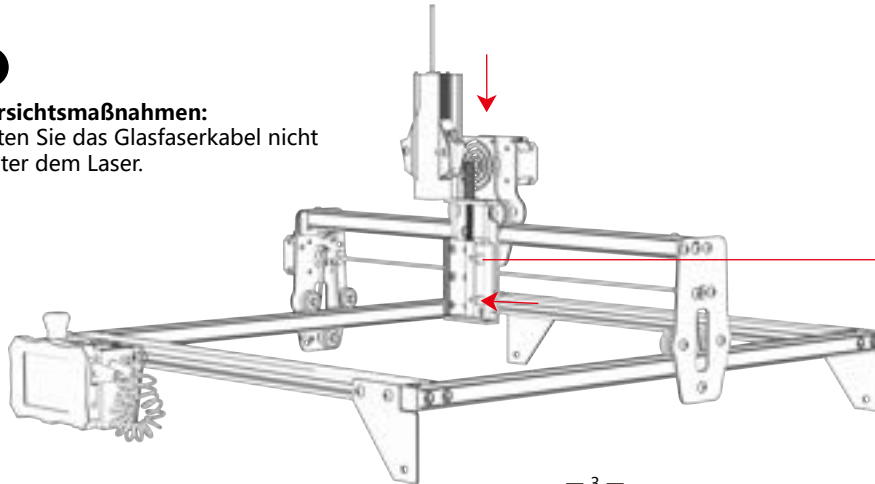

Ziehen Sie die Schrauben fest

Möglichkeit 2 Verbinden Sie die Z-Achse und den Schieber von vorne mit der Maschine.

1

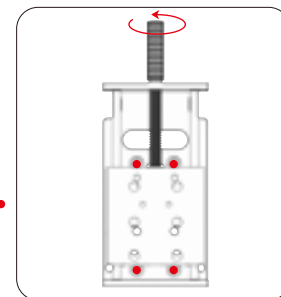
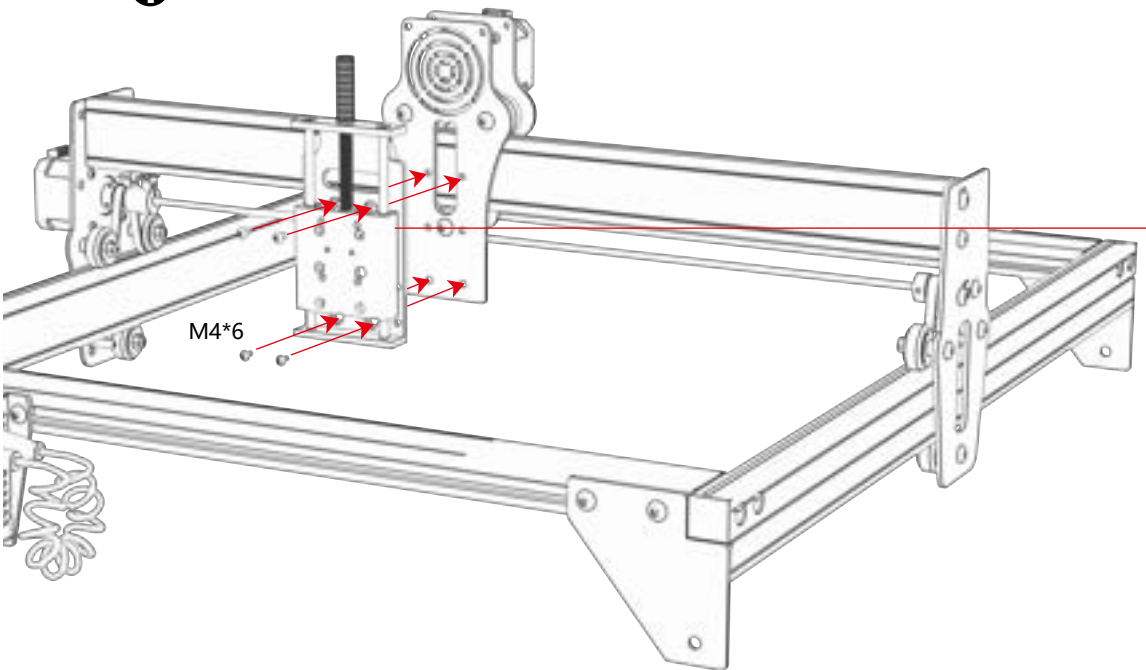

Drehen Sie den Griff, um den Schieberegler zu verschieben.

2

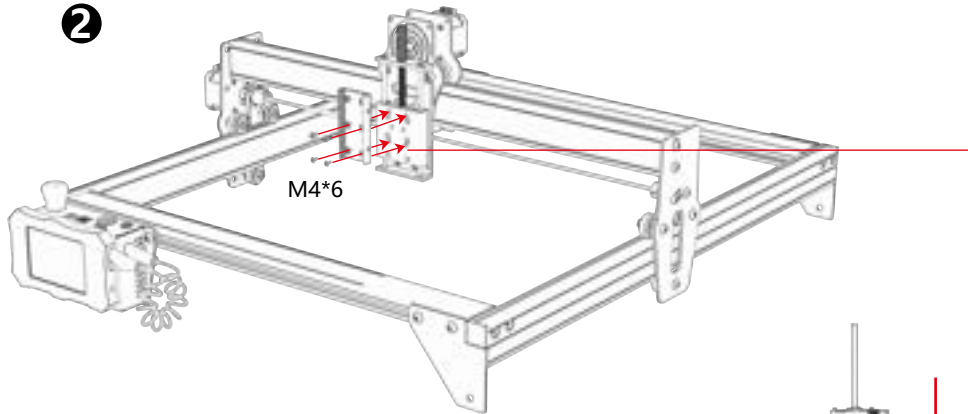

M4*6

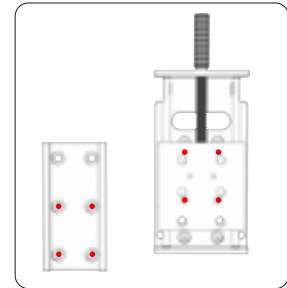

3

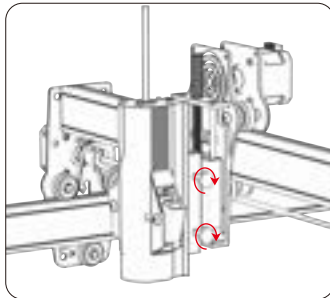

Ziehen Sie die Schrauben fest

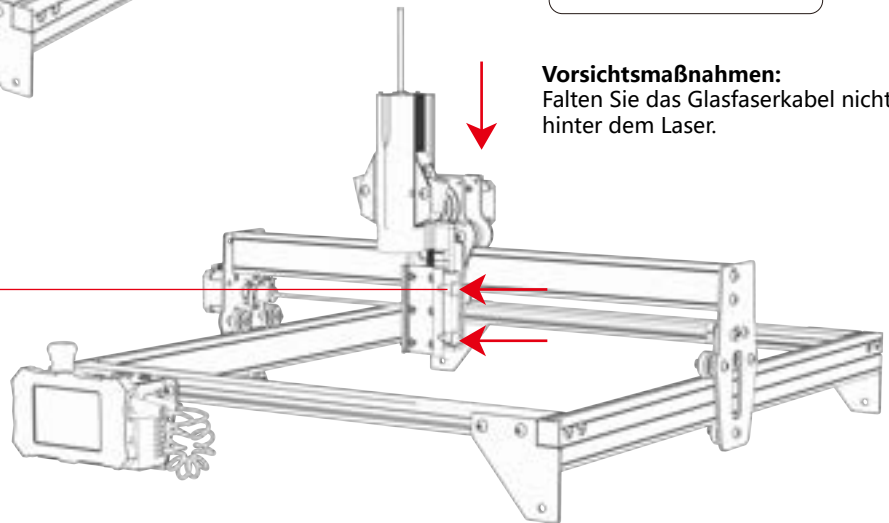

Vorsichtsmaßnahmen:
Falten Sie das Glasfaserkabel nicht
hinter dem Laser.

Möglichkeit 3

Diese Art der Z-Achse muss nicht ausgetauscht werden und kann direkt in den Laserkopf eingesetzt werden.

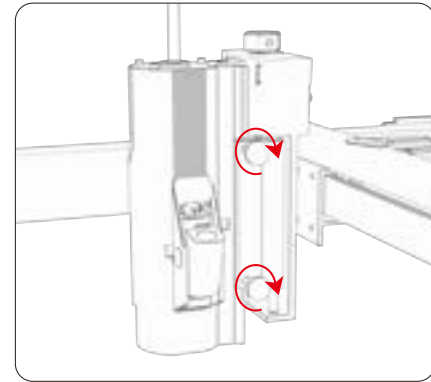
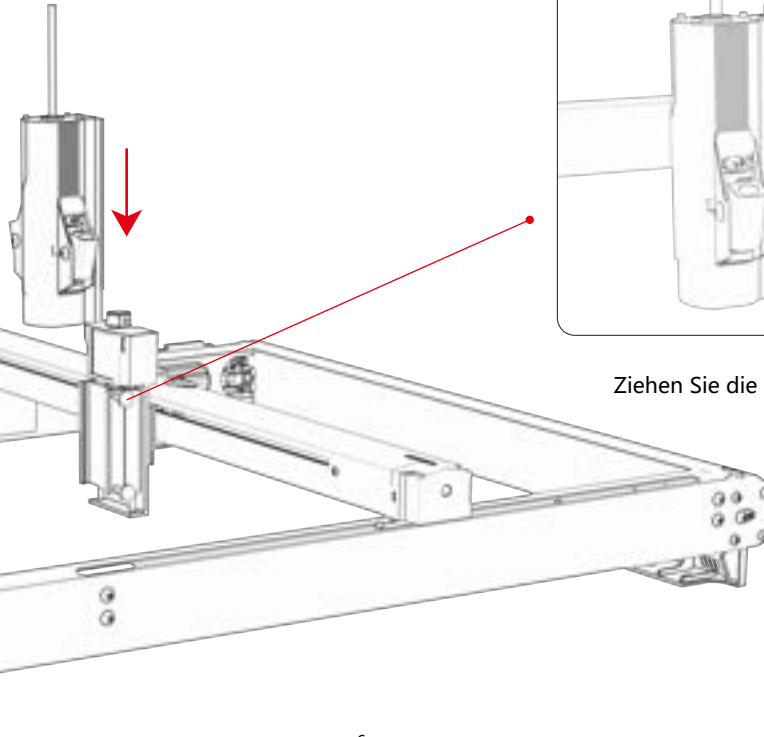
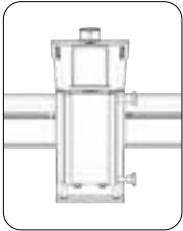

Ziehen Sie die Schrauben fest

Schritt 2 Tauschen Sie das Steuergerät aus

Methode 1 Der Steuerkasten für die Probeinstallation wird mit der Bohrungsposition vor dem Typ gepaart, und der Steuerkasten wird direkt installiert.

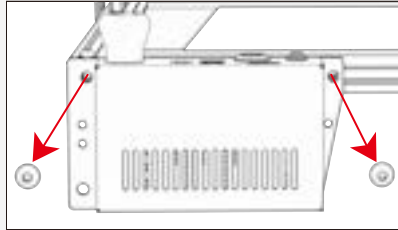

Entfernen Sie den Original-Schaltkasten und das Originalkabel

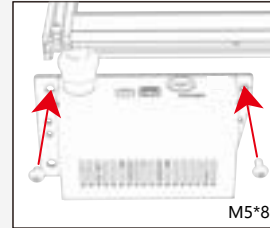

Installieren des Stueurelements im Manifest

Methode 2 Der Versuchssteuerkasten ist nicht auf die Lochposition vor dem Typ abgestimmt, und es ist notwendig, eine T-Mutter zu tragen und zwei M5*8-Schrauben zu verriegeln.

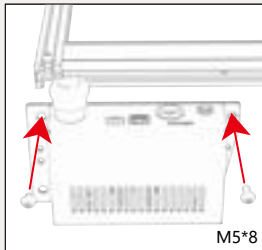

Installieren des Stueurelements im Manifest

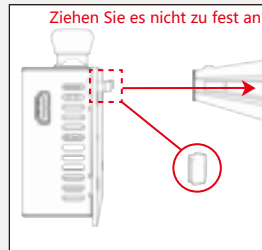

Montieren Sie die T-Mutter

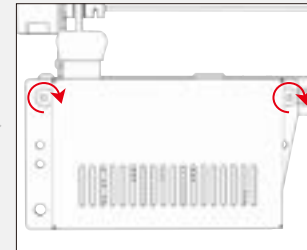

Ziehen Sie die Schrauben fest

Schritt 3 Anschließen von Kabeln

Control line
Laser-Signalkabel
Typ-C-Datenkabel

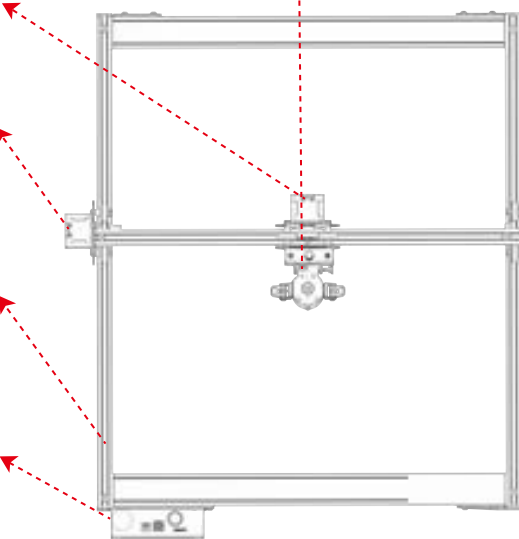
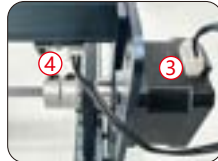
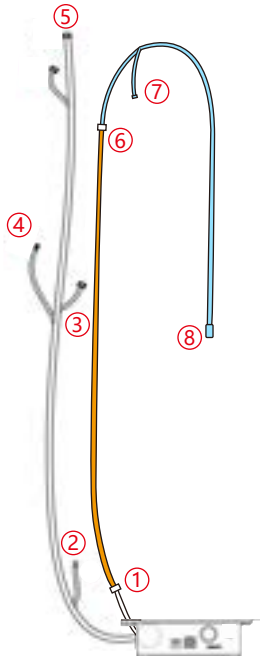

Hinweis:
Um den Original-Laserkopf zu verwenden, muss die Steuerbox nicht erneut zerlegt werden. Verbinden Sie diese beiden Drähte einfach miteinander.

Schritt 4 Testprozess - Einschalten

1. Schalten Sie den Netzschalter der Maschine ein



Schalten Sie zuerst den Netzschalter der Maschine ein und schalten Sie dann den Schalter der Faserlaser-Steuerbox ein, um nach dem Einschalten eine probabilistische Lichtemission von etwa 2 Sekunden zu vermeiden.

2. Fokus-Einstellung

1) Positionieren Sie das Testmaterial auf der Maschine.

2) Beobachten Sie, ob sich die roten Lichtflecken am linken und rechten Ende des Laserkopfes überlappen. Wenn nicht, stellen Sie die Höhe ein, indem Sie den Knopf auf der Z-Achse drehen, damit die beiden Punkte zusammenfallen.

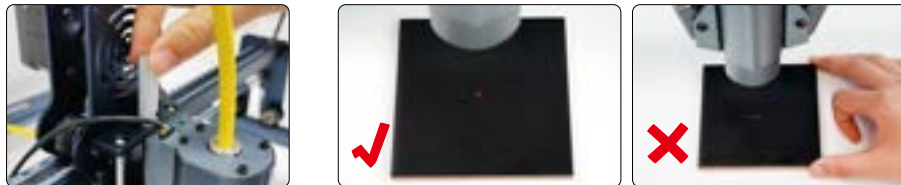

3. Laser-Frequenzanpassung

Die Frequenz der Steuerbox kann von 30 kHz bis 60 kHz eingestellt werden. Die Anpassungen entnehmen Sie bitte der Parametertabelle.(S. 16-19)



Schritt 5: Testprozess - Verwendung auf dem PC

1) Wenn Sie Lightburn für die Online- oder Offline-Gravur von Bildern und die Musterfüllung verwenden, wird empfohlen, das Overscanning zu aktivieren, um bessere Gravurergebnisse zu erzielen.

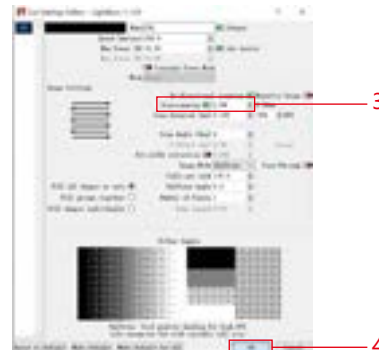
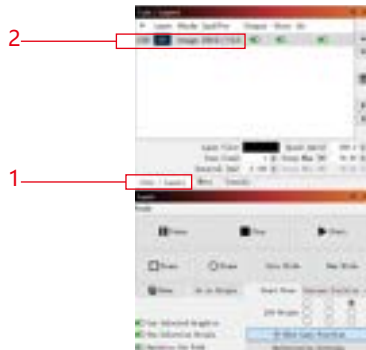

2) In der Bedienungsanleitung des Geräts finden Sie Anweisungen zur Verwendung von Lightburn. Der einzige Unterschied liegt in der Rahmung. Wählen Sie für das Framing in Lightburn "Verschieben" > "Power" und setzen Sie es auf 0. Sie können den Framing-Prozess durch die rote Lichtanzeige überwachen.

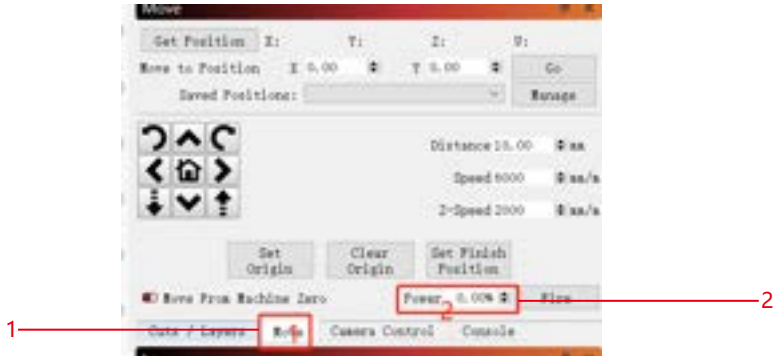

3) Anweisungen zur Verwendung von LaserGRBL finden Sie in der Bedienungsanleitung des Geräts. Der einzige Unterschied liegt in der Rahmung. Beim Framen in LaserGRBL muss die Framing-Energie auf 0 geändert werden.



1. Klicken Sie mit der rechten Maustaste auf Rahmen und klicken Sie auf die Schaltfläche Bearbeiten.

2. Auf 50 setzen



3. Retten

Schritt 6 Testprozess - Offline-Nutzung der K1-Maschine

1) Wenn Sie einen blauen Laser offline mit Lightburn verwenden, klicken Sie auf "Bearbeiten" und wählen Sie "Maschineneinstellungen". Ändern Sie den PWM-Mindestwert (\$35) von 0 auf 1. Beachten Sie, dass \$35 von FL20 auf 0 und der von blauem Laser auf 1 gesetzt werden sollte.

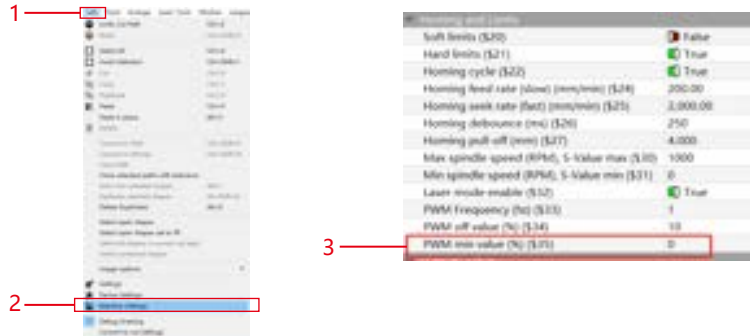

2) Wenn Sie einen blauen Laser offline mit GRBL verwenden, klicken Sie auf "Grbl" und wählen Sie "Grbl-Konfiguration". Ändern Sie den Wert von \$35 von 0 in 1. Beachten Sie, dass \$35 von FL20 auf 0 und der von blauem Laser auf 1 gesetzt werden sollte.

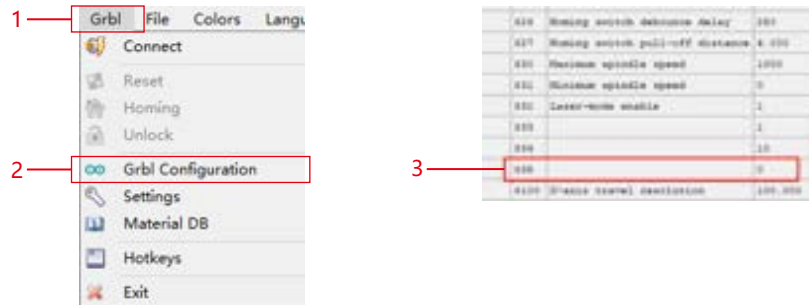

Schritt 7 Testprozess - Offline-Nutzung der A40 Pro-Maschine

1) Wenn Sie einen blauen Laser offline mit Lightburn verwenden, klicken Sie auf "Bearbeiten" und wählen Sie "Maschineneinstellungen". Ändern Sie den PWM-Mindestwert (\$35) von 0 auf 1. Beachten Sie, dass \$35 von FL20 auf 0 und der von blauem Laser auf 1 gesetzt werden sollte.

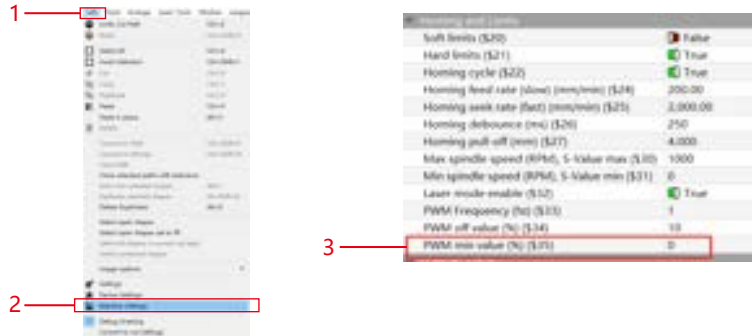

2) Wenn Sie einen blauen Laser offline mit GRBL verwenden, klicken Sie auf "Grbl" und wählen Sie "Grbl-Konfiguration". Ändern Sie den Wert von \$35 von 0 in 1. Beachten Sie, dass \$35 von FL20 auf 0 und der von blauem Laser auf 1 gesetzt werden sollte.

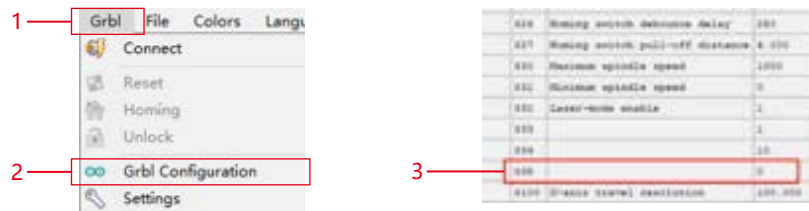

Schritt 8 Testprozess - Offline-Einsatz ohne Maschinenversand

1) lightburn: Wenn Sie einen blauen Laser offline verwenden, klicken Sie auf "Bearbeiten" und wählen Sie "Maschineneinstellungen". Ändern Sie den PWM-Mindestwert (\$60) von 0 auf 1. Beachten Sie, dass \$60 von FL20 auf 0 und der von blauem Laser auf 1 gesetzt werden sollte.

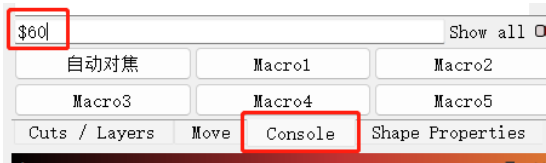

2) GRBL: Wenn Sie einen blauen Laser offline verwenden, klicken Sie auf "Grbl" und wählen Sie "Grbl-Konfiguration". Ändern Sie den Wert für 60 \$ von 0 in 1. Beachten Sie, dass \$60 von FL20 auf 0 und der von blauem Laser auf 1 gesetzt werden sollte.

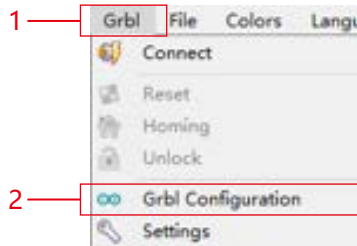

3.lightburn Gravurleistungseinstellungen: Power Max(%) > 10%, siehe Parametertabelle für spezifische Werte.

Bitte beachten Sie: Der Gravurvektormodus sollte auf "M3-Modus" eingestellt sein. Führen Sie die folgenden Schritte aus, um zu arbeiten: "Schnitte / Schichten" -> "Linie" -> "Konstantleistungsmodus".



Schritt 9 FAQ

1) Wenn der Gravur- oder Schneideeffekt nicht zufriedenstellend ist:

- Prüfen Sie, ob sich der Laser in der Fokusposition befindet.
- Überprüfen Sie die Sauberkeit des Objektivs.

2) Wenn eine Fehlfunktion der Rotlichtanzeige vorliegt und es unbequem ist, die Brennweite durch überlappende rote Lichter zu überprüfen, können Sie die Brennweite durch die Fixfokusmethode einstellen (Abstand von der Laserendfläche zum Messobjekt: 96,1 mm / 94,1 mm).

3) Wenn sich keine Spuren oder ungleichmäßige Energie in den gravierten Vektorlinien befinden:





- Prüfen Sie, ob sich der Laser in der Fokusposition befindet.
- Vergewissern Sie sich, dass es im M3-Konstantleistungsmodus betrieben wird.





Anmerkung:







1. Unsere Parameterliste gilt nur für die am häufigsten verwendeten Materialien. Kunden müssen möglicherweise andere ungewöhnliche Materialien selbst ausprobieren, oder sie können sich an uns wenden, um einen Test zu beantragen.







2. Der Linienmodus für Vektorlinien erfordert den M3-Modus

Gravurparameter für gängiges Material

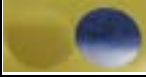
Material	Gravieren						
	Qualität	Geschwindigkeit (mm/m)	Max-Leistung	Frequenz (KHz)	Bild-Modus	Muss ein schwarzes Ende haben	Muss ein schwarzes Ende haben
Kupfer	100	7000	800	30	Schwelle	Nein	
Eisen	100	5000	800	30	Schwelle	Nein	
Natürliche Farbe Aluminiumoxid	100	10000	800	30	Schwelle	Nein	
Beschichtetes Aluminiumoxid	100	7000	800	30	Schwelle	Nein	

Gebürsteter Edelstahl	100	5000	500	30	Schwelle	Nein	
Spiegel Edelstahl	100	6000	800	40	Schwelle	Nein	
bemalte Möbel	100	10000	600	30	Schwelle	Nein	
ABS	100	10000	400	30	Schwelle	Nein	
Plastik	100	15000	800	30	Schwelle	Nein	

Material	Gravieren						
	Qualität	Speed (mm/m)	Max-Leistung	Frequenz (KHz)	Bild-Modus	Muss ein schwarzes Ende haben	Muss ein schwarzes Ende haben
Leder	100	10000	700	30	Schwelle	Nein	
Acryl	100	13000	700	30	Schwelle	Nein	
Gummi	100	6000	600	30	Schwelle	Nein	
Öl-Malpapier	100	12000	700	30	Schwelle	Nein	
Fels	100	15000	800	30	Schwelle	Nein	
Spiegel	100	12000	500	30	Schwelle	Ja	
Keramische Fliesen	100	5000	800	30	Schwelle	Ja	

Schnittparameter für gängiges Material							
Material	Schneiden						
	Dicke (mm)	Speed (mm/m)	Max-Leistung	Frequenz (KHz)	Anzahl der Durchgänge	Muss ein schwarzes Ende haben	Muss ein schwarzes Ende haben
Gummi	2	1000	800	30	30	Nein	
Aluminium-Visitenkarte	0.2	300	800	30	1	Nein	
Edelstahlblech	0.15	300	800	30	1	Nein	
EVA-Schaum	8	1000	800	30	1	Nein	
Leder	2	300	800	30	1	Nein	
Kupfer	0.5	100	1000	30	50	Nein	
Eisen	0.5	100	1000	30	50	Nein	
Aluminium-Visitenkarte	0.5	100	1000	30	50	Nein	



Kundenservice:

Ausführliche Informationen zur Garantie finden Sie auf unserer offiziellen Website: www.atomstack.com
Für technische Unterstützung und Service, senden Sie bitte eine E-Mail :support@atomstack3d.com

Hersteller:

Shenzhen AtomStack Technologies Co.,Ltd

Adresse:

AB301,New Chabridge Industrial Park,No.3,Baolong 6th Rd.,Longgang Dist,Shenzhen,Guangdong,china

Schwirren: 518116

QR-Code scannen:

QR-Code-Leser/Barcode-Scanner oder eine beliebige App mit einem Scanner



- Français

ATOMSTACK

ATOMSTACK MR 20

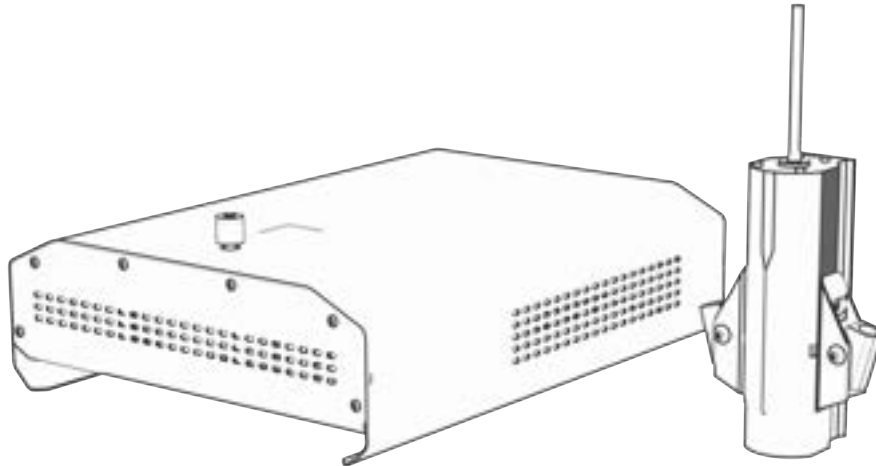

F03-0198-0AA1 Version: A



Laser Engraver

Remarque: L' image est à titre indicatif uniquement, le produit réel prévaudra.
Pour plus d' informations, veuillez scanner le code QR

Liste de colisage

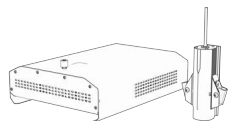

Module laser



Câble de données TYPE-C



Câble de signal laser



Câble d'alimentation



Composant de l'axe Z



Curseur laser



Vis moletées 2PCS (M4*12)



Vis 8PCS (M4X6)



Vis 2PCS (M5X8)



Vis 4PCS (M4X10)

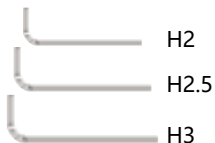

Clé Allen



Boîtier de commande



Écrou en T 2PCS

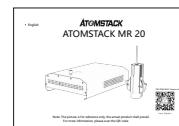

Manuel

Étape 1 Connectez l'axe Z et le curseur à la machine

Option 1 Connectez l'axe Z et le curseur à la machine par l'arrière.

1

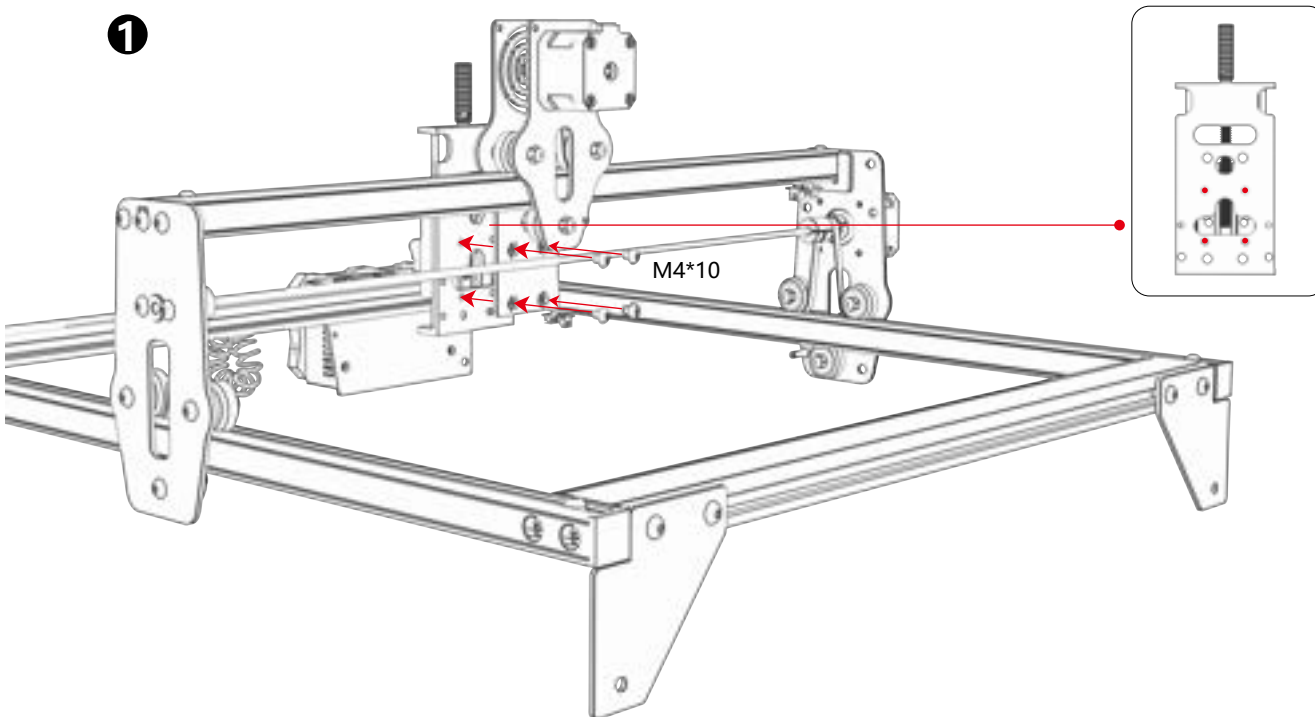

2

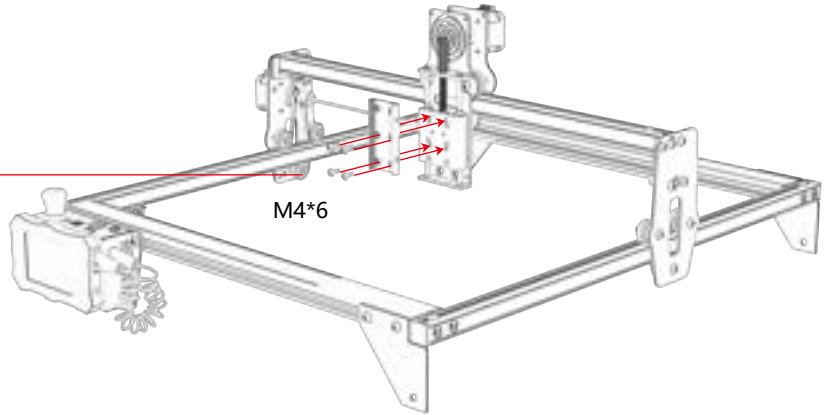
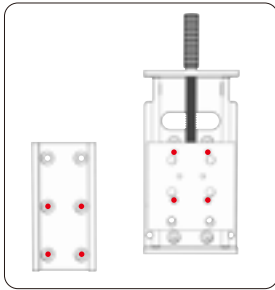

M4*6

3

Précautions:
Ne pliez pas le câble à fibre optique
derrière le laser.

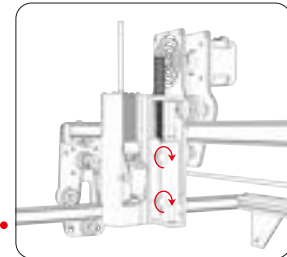
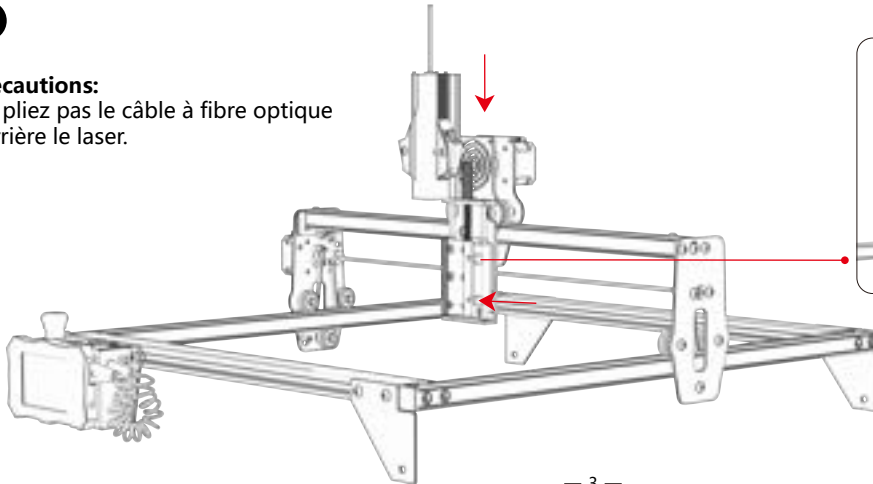

Serrez les vis

Option 2 Connectez l'axe Z et le curseur à la machine par l'avant.

1

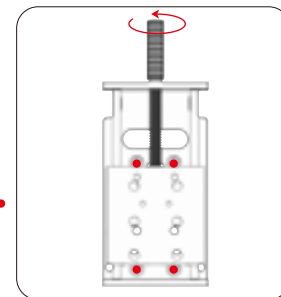
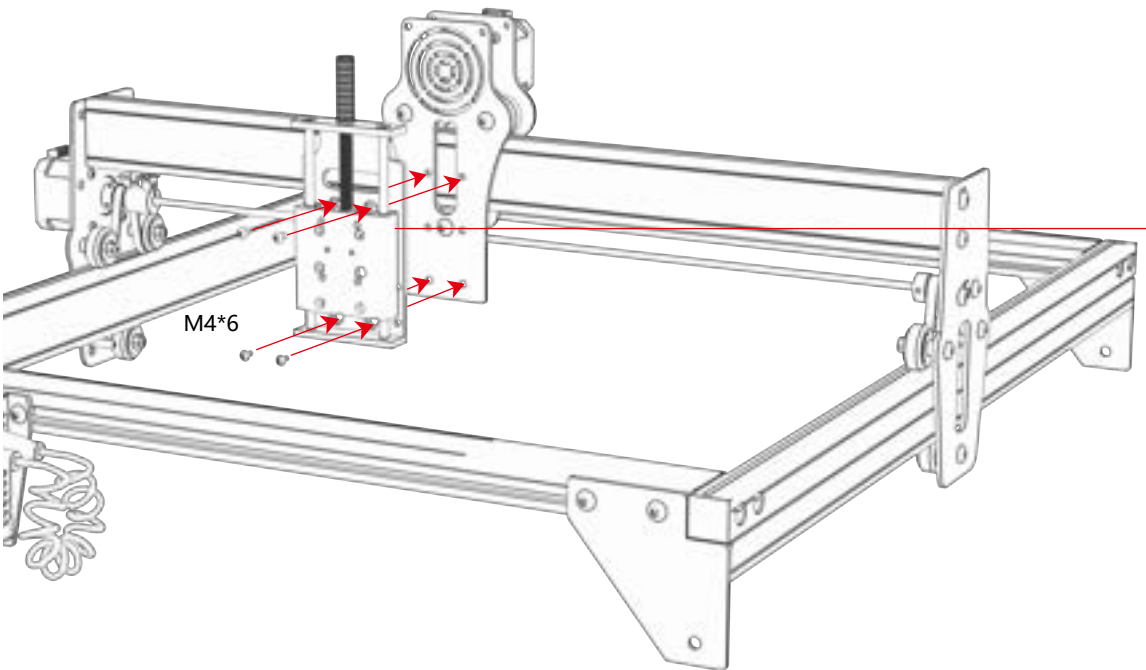

Faites pivoter la poignée pour déplacer le curseur.

2

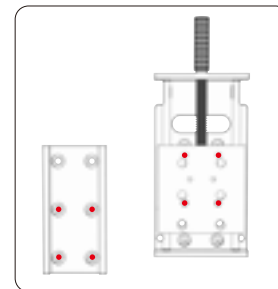
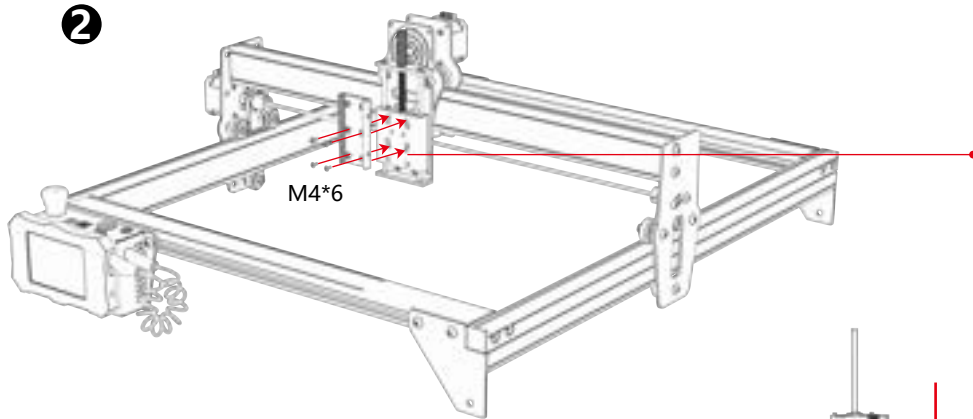

3

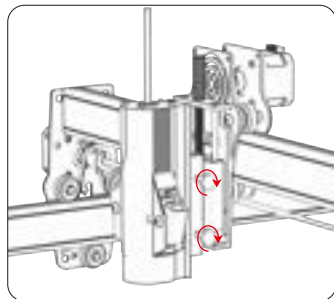

Serrez les vis

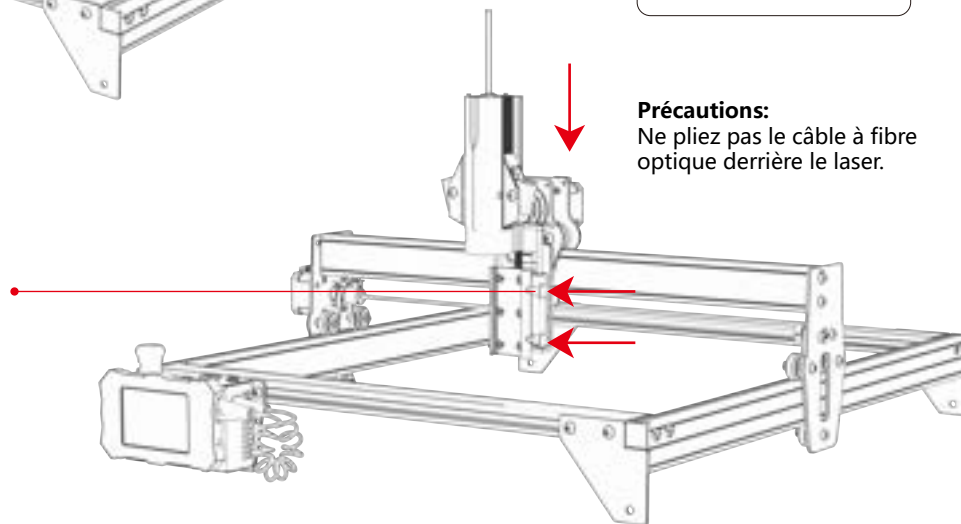

Option 3 Ce type d' axe Z ne nécessite pas de remplacement et peut être inséré directement dans la tête laser.

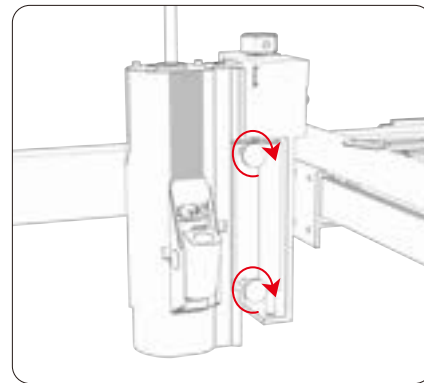
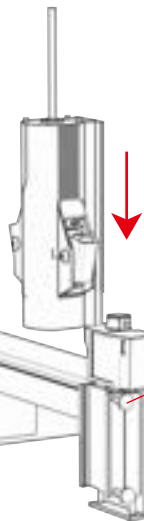
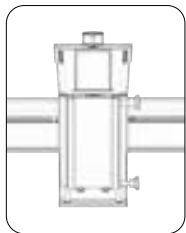

Serrez les vis

Étape 2 Remplacez le boîtier de commande

Méthode 1

Der Steuerkasten für die Probeinstallation wird mit der Bohrungsposition vor dem Typ gepaart, und der Steuerkasten wird direkt installiert.

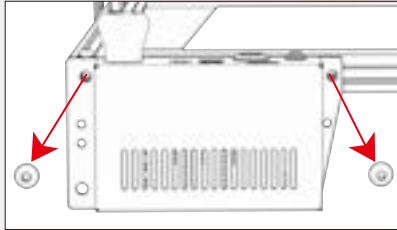

Retirez le boîtier de commande et le câble d'origine.

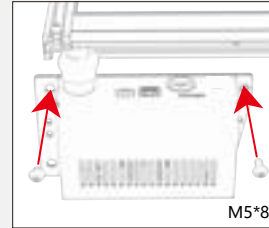

Installer le boîtier de contrôle dans le manifeste

Méthode 2

Le boîtier de commande d'essai n'est pas assorti à la position du trou devant le type, et il est nécessaire de porter un écrou en T et de verrouiller deux vis M5 * 8.

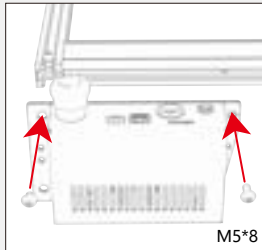

Installer le boîtier de contrôle dans le manifeste

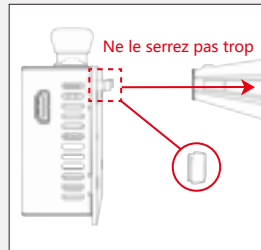

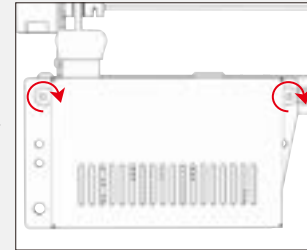

Installez l'écrou en T



Serrez les vis

Étape 3 Connexion de câbles

-  Control line
-  Câble de signal laser
-  Câble de données de type C

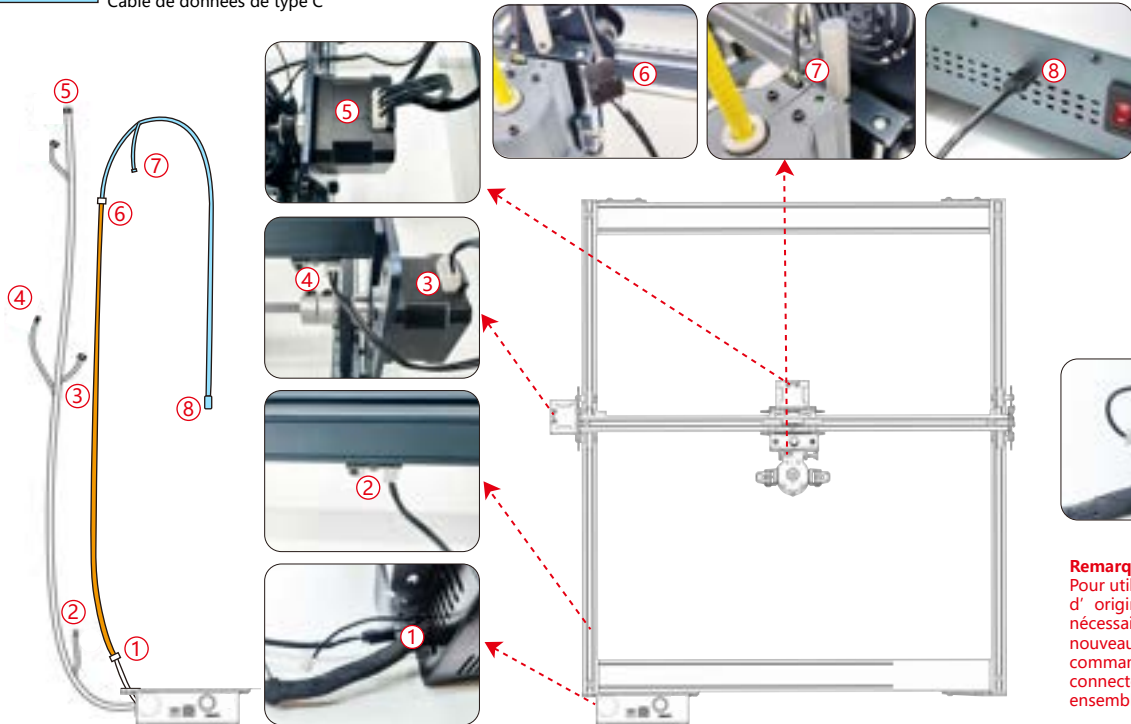

Remarque:
Pour utiliser la tête laser d'origine, il n'est pas nécessaire de démonter à nouveau le boîtier de commande. Il suffit de connecter ces deux fils ensemble.

Étape 4 Processus de test - Mise sous tension

1. Allumez l' interrupteur d' alimentation de la machine



Allumez d' abord l' interrupteur d' alimentation de la machine, puis allumez l' interrupteur du boîtier de commande laser à fibre pour éviter environ 2 secondes d' émission de lumière probabiliste après la mise sous tension.

2. Ajustement de la mise au point

- 1) Placez le matériel d' essai sur la machine.
- 2) Observez si les taches de lumière rouge aux extrémités gauche et droite de la tête laser se chevauchent. Sinon, réglez la hauteur en tournant le bouton sur l' axe Z pour faire coïncider les deux points.

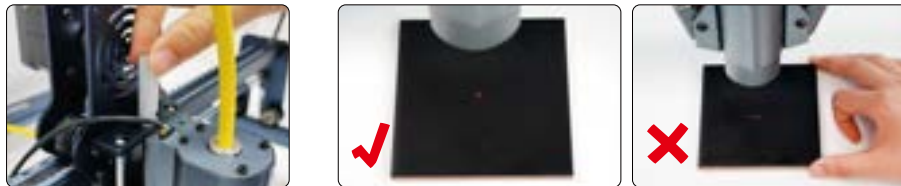

3. Réglage de la fréquence laser

La fréquence du boîtier de commande peut être réglée de 30kHz à 60kHz. Reportez-vous au tableau des paramètres pour les ajustements.(p. 16 à 19)



Étape 5 Processus de test - Utilisation sur PC

1) Lorsque vous utilisez Lightburn pour la gravure en ligne ou hors ligne d'images et le remplissage de motifs, il est recommandé d'activer le surbalayage pour de meilleurs résultats de gravure.

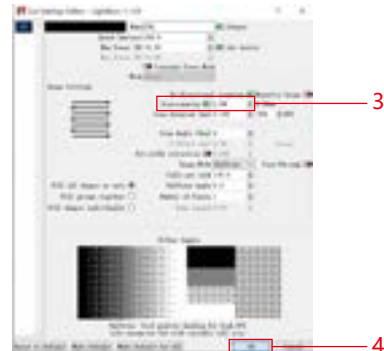
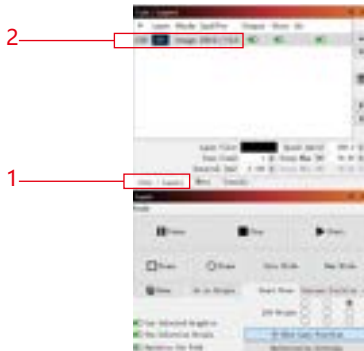

2) Reportez-vous au manuel d' utilisation de la machine pour obtenir des instructions sur l' utilisation de Lightburn. La seule différence réside dans le processus de cadrage. Pour le cadrage dans Lightburn, sélectionnez « Déplacer » > « Alimentation » et réglez-le sur 0. Vous pouvez surveiller le processus de cadrage via l' indicateur de lumière rouge.

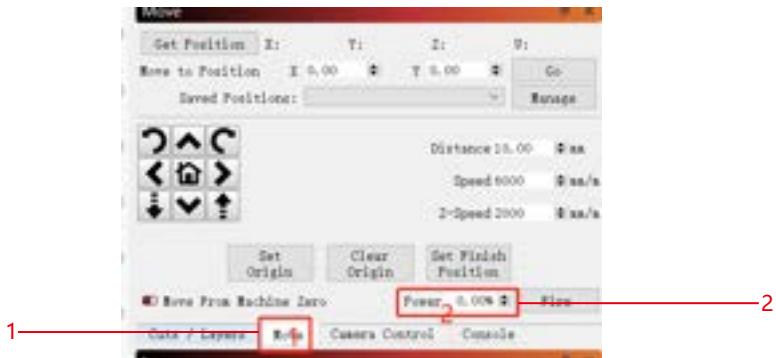

3) Reportez-vous au manuel d' utilisation de la machine pour obtenir des instructions sur l' utilisation de LaserGRBL. La seule différence réside dans le processus de cadrage. Lors de l' exécution du cadrage dans LaserGRBL, l' énergie de cadrage doit être modifiée à 0.



1. Cliquez avec le bouton droit sur Cadre, puis cliquez sur le bouton Modifier.

2. Défini sur S0



3. Sauvegarder

Étape 6 Processus de test - Utilisation hors ligne de la machine K1

1) Lorsque vous utilisez un laser bleu hors ligne avec une brûlure de lumière, cliquez sur « Modifier » et sélectionnez « Paramètres de la machine ». Modifiez la valeur PWM min (35 \$) de 0 à 1. Notez que 35 \$ de FL20 doit être réglé sur 0 et celui du laser bleu doit être réglé sur 1.

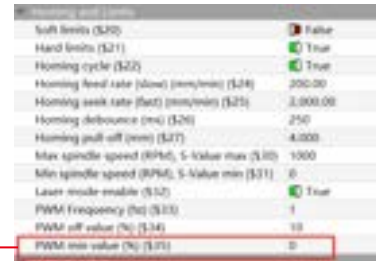

2) Lorsque vous utilisez un laser bleu hors ligne avec GRBL, cliquez sur « Grbl » et sélectionnez « Configuration Grbl ». Modifiez la valeur de 35 \$ de 0 à 1. Notez que 35 \$ de FL20 doit être réglé sur 0 et celui du laser bleu doit être réglé sur 1.

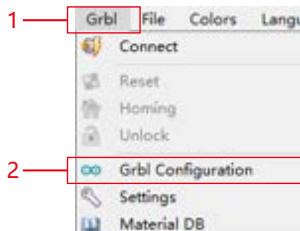

Étape 7 Processus de test - Utilisation hors ligne de la machine A40 Pro

1) Lorsque vous utilisez un laser bleu hors ligne avec une brûlure de lumière, cliquez sur « Modifier » et sélectionnez « Paramètres de la machine ». Modifiez la valeur PWM min (35 \$) de 0 à 1. Notez que 35 \$ de FL20 doit être réglé sur 0 et celui du laser bleu doit être réglé sur 1.

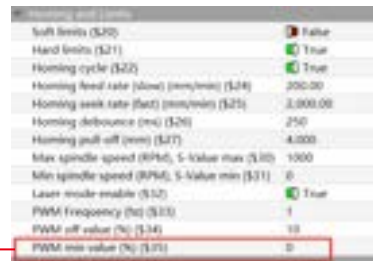

2) Lorsque vous utilisez un laser bleu hors ligne avec GRBL, cliquez sur « Grbl » et sélectionnez « Configuration Grbl ». Modifiez la valeur de 35 \$ de 0 à 1. Notez que 35 \$ de FL20 doit être réglé sur 0 et celui du laser bleu doit être réglé sur 1.

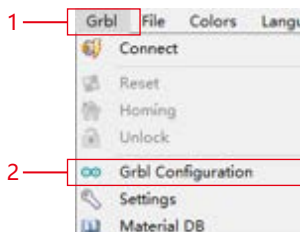

Étape 8 Processus de test - Utilisation hors ligne sans expédition de machine

1) lightburn: Lorsque vous utilisez un laser bleu hors ligne, cliquez sur « Modifier » et sélectionnez « Paramètres de la machine ». Modifiez la valeur PWM min (60 \$) de 0 à 1. Notez que 60 \$ de FL20 doit être réglé sur 0 et celui du laser bleu doit être réglé sur 1.

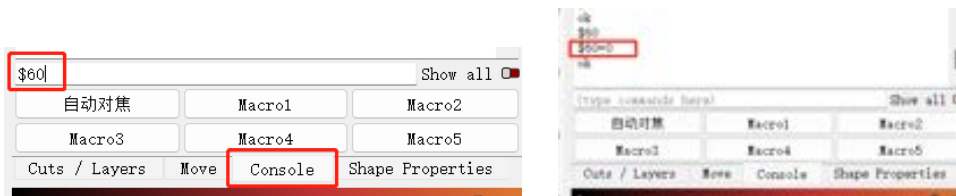

2) GRBL: Lorsque vous utilisez un laser bleu hors ligne, cliquez sur « Grbl » et sélectionnez « Configuration Grbl ». Modifiez la valeur de 60 \$ de 0 à 1. Notez que 60 \$ de FL20 doit être réglé sur 0 et celui du laser bleu doit être réglé sur 1.



3.lightburn Paramètres de puissance de gravure: Power Max (%) > 10%, reportez-vous au tableau des paramètres pour les valeurs spécifiques.

Remarque : Le mode vectoriel de gravure doit être réglé sur « mode M3 ». Suivez les étapes ci-dessous pour fonctionner: « Coupes / Calques » -> « Ligne » -> « Mode de puissance constante ».



Étape 9 FAQ

1) Si l' effet de gravure ou de découpe n' est pas satisfaisant :

- Vérifiez si le laser est en position focale.
- Vérifiez la propreté de la lentille.

2) S' il y a un dysfonctionnement avec l' indicateur de lumière rouge et qu' il n' est pas pratique de vérifier la distance focale à travers des lumières rouges qui se chevauchent, vous pouvez ajuster la distance focale par la méthode de mise au point fixe (distance de la face d' extrémité laser à l' objet mesuré: 96,1 mm / 94,1 mm).

3) S' il n' y a pas de traces ou d' énergie inégale dans les lignes vectorielles gravées:





- Vérifiez si le laser est en position focale.
- Confirmez s' il fonctionne en mode de puissance constante M3.





Remarque:







1. Notre liste de paramètres ne concerne que les matériaux les plus utilisés. Les clients peuvent avoir besoin d'essayer d'autres matériaux inhabituels par eux-mêmes, ou ils peuvent nous contacter pour postuler pour des tests.









2. Le mode Ligne pour les lignes vectorielles nécessite le mode M3

Paramètre de gravure pour un matériau commun

Matériel	Gravure						
	Qualité	Vitesse (mm/m)	Puissance maximale	Fréquence (KHz)	Image Mode	Doit être noirci	Illustration de cas
Cuivre	100	7000	800	30	Seuil	Non	
Fer	100	5000	800	30	Seuil	Non	
Alumine de couleur naturelle	100	10000	800	30	Seuil	Non	
Alumine enrobée	100	7000	800	30	Seuil	Non	

Acier inoxydable brossé	100	5000	500	30	Seuil	Non	
Miroir en acier inoxydable	100	6000	800	40	Seuil	Non	
meubles peints	100	10000	600	30	Seuil	Non	
ABS	100	10000	400	30	Seuil	Non	
Plastique	100	15000	800	30	Seuil	Non	

Matériel	Gravure						
	Qualité	Vitesse (mm/m)	Puissance maximale	Fréquence (KHz)	Image Mode	Doit être noirci	Illustration de cas
Cuir	100	10000	700	30	Seuil	Non	
Acrylique	100	13000	700	30	Seuil	Non	
Caoutchouc	100	6000	600	30	Seuil	Non	
Papier de peinture à l'huile	100	12000	700	30	Seuil	Non	
Rocher	100	15000	800	30	Seuil	Non	
Miroirs	100	12000	500	30	Seuil	Oui	
Carreau de céramique	100	5000	800	30	Seuil	Oui	

Paramètre de coupe pour un matériau commun							
Matériel	Découpage						Illustration de cas
	Épaisseur (mm)	Vitesse (mm/m)	Puissance maximale	Fréquence (KHz)	Nombre de laissez-passer	Doit être noirci	
Caoutchouc	2	1000	800	30	30	Non	
Carte de visite en aluminium	0.2	300	800	30	1	Non	
Tôle d'acier inoxydable	0.15	300	800	30	1	Non	
Mousse EVA	8	1000	800	30	1	Non	
Cuir	2	300	800	30	1	Non	
Cuivre	0.5	100	1000	30	50	Non	
Fer	0.5	100	1000	30	50	Non	
Carte de visite en aluminium	0.5	100	1000	30	50	Non	



Service à la clientèle :

Pour une politique de garantie détaillée, veuillez consulter notre site officiel : www.atomstack.com.

Pour l'assistance technique et le service, veuillez envoyer un courriel à support@atomstack3d.com

Fabricant :

Shenzhen AtomStack Technologies Co.,Ltd.

Adresse :

AB301, New Chabridge Industrial Park, No.3, Baolong 6th Rd., Longgang Dist, Shenzhen, Guangdong, China

Fermeture éclair : 518172

Scanner le code QR :

Lecteur de code QR/numériseur de codes-barres ou toute application avec un numériseur.

