



ESSENTIALS COMFORT



USER MANUAL



SOS Help
Watch



GPS Data
Location



In-/Outdoor
Connectivity



2-Way
Speaker

Zembro Essentials Comfort

Zembro Essentials Comfort is an SOS watch for raising an alert.

FEATURES

- Outdoor/indoor alerting via button press
- Call button, with in-built microphone and speaker
- Clear voice quality.
- Always connected due to in-built SIM card with coverage throughout Europe.

Your Zembro Essentials Comfort is a rechargeable SOS watch that features an in-built SIM card, so it stays connected to Zembro when you are indoors and outdoors.

Your Zembro Essentials Comfort is designed to be first and foremost a watch, as well as a highly reliable alerting device that is always with you.

It works indoors and outdoors, where there is GSM & GPS connectivity.

Getting To Know Your Watch

FRONT



Getting To Know Your Watch

BACK



Getting To Know Your Device

SIDE

SIM Card Holder

It is prohibited
to remove the
SIM card



Speaker



Accessories



USB Cable



Silicone Watch Strap



Charging Base

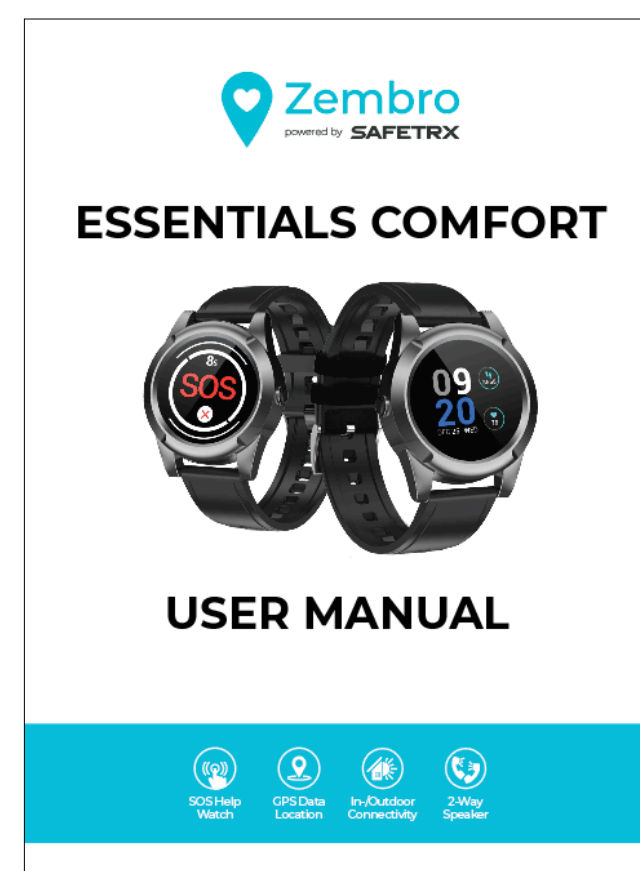

English User Manual

Please consult our website for the most recent user manual in Dutch, English, French and German.

Charging your Watch



- Connect the USB cable from the charging base to the AC adaptor
- Place the watch into the charging base correctly, you will hear spoken confirmation *"Your watch is charging"*.
- Please fully charge the battery daily for around 2 hours or when the battery is low.
- In addition to charging daily, we strongly recommend recharging your device after using the SOS function.

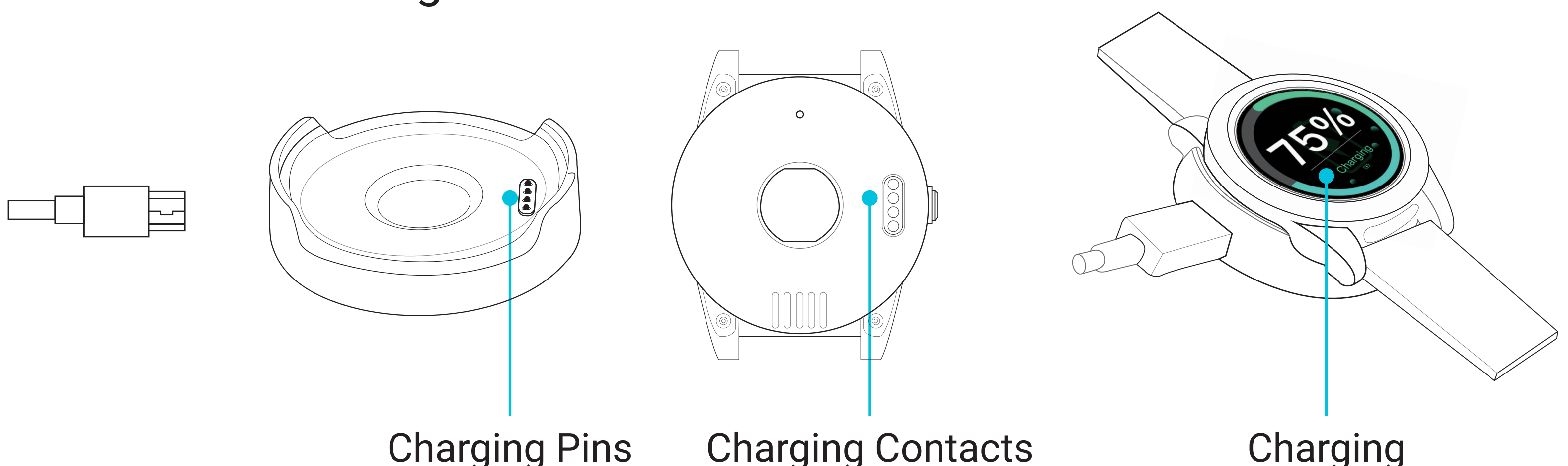

TIP The watch battery is not removable. After a long period of inactivity, the watch may not be turned on due to low battery. Please charge it every day to ensure that the watch can function normally.

Battery life varies by use and configuration of your Zembro Essentials Comfort; actual results will vary.

Functions and Basic Settings

When the watch is turned on, activate the touchscreen by briefly pressing on the side button, then swipe left to view all available functions.

It displays the digital watch face, heart rate, and steps.

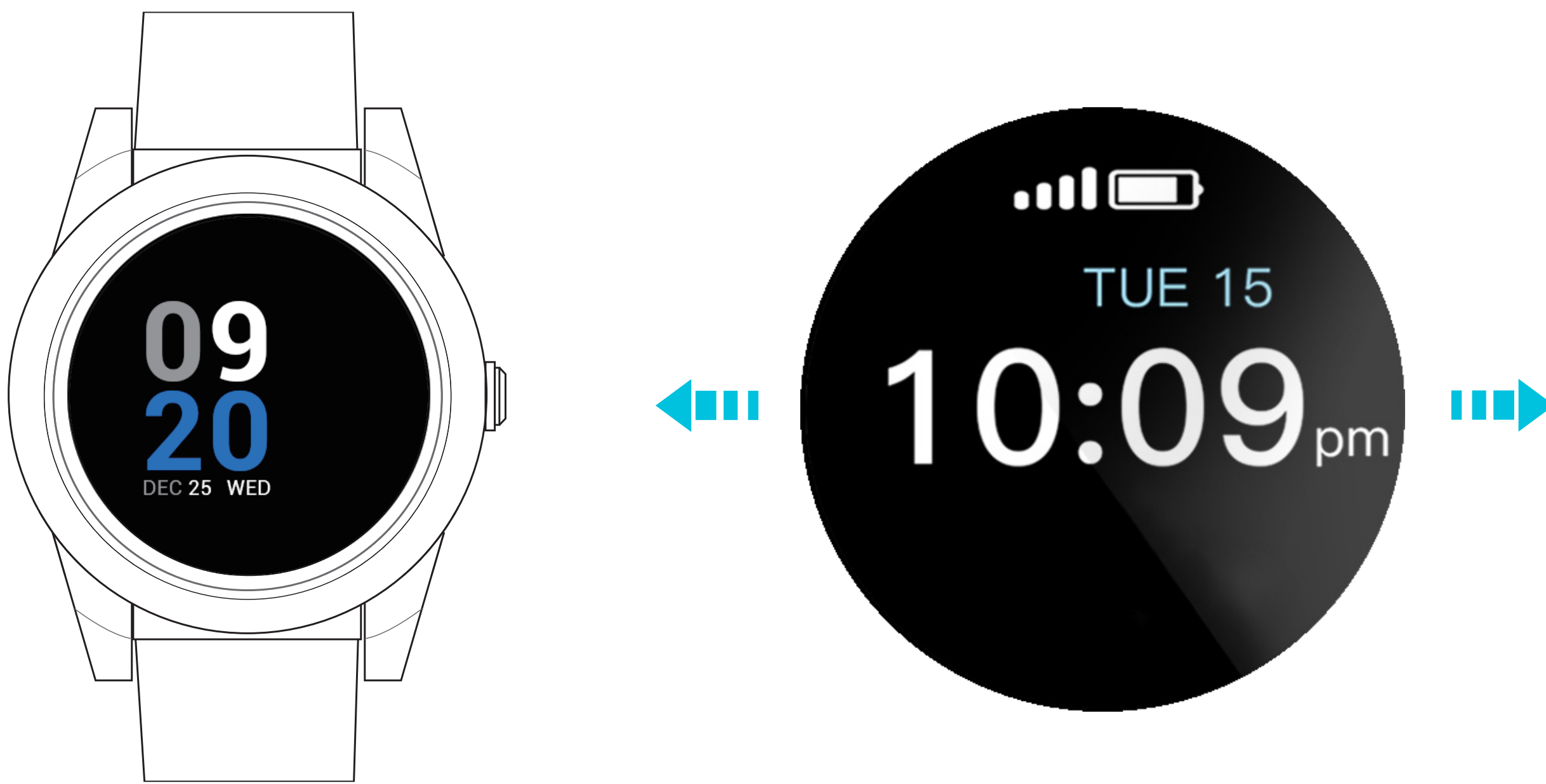

- On the digital watch face, you can see time, date, battery level, heart rate, and steps.
- The battery level on your watch is visible via the icon located on the top of the digital watch face.
- If the battery drops below 20%, the wearer will receive a voice prompt via the watch in addition to an sms. The designated emergency contacts can also choose to receive a low battery notification by sms and/or email.
- In the future, the battery level will also be featured in the Zembro Safetrx web application.

Activating an SOS Alarm

To activate an SOS alarm, long press on the button to the side of your watch:



Press the side button for 3 seconds until you feel the watch vibrate.

Activating an SOS Alarm

After a SOS alarm is activated, you will hear a voice prompt confirming the activation of the SOS alarm and allowing you approximately 10 seconds to cancel the alarm by pressing on the side button of your watch until the alarm is cancelled. This is confirmed by a voice prompt.

If the SOS alarm is not cancelled in time, a SOS alarm text message is immediately sent to the emergency contact numbers followed by the outgoing calls.

If the watch fails to connect to the first number, it will call the second number after a delay of 10 seconds.

In case the second number fails to be connected to as well, the system will connect to the third number, etc.

Between each call, the system waits for 10 seconds. During this time, the user can stop the call sequence or prevent a possible false alarm by pressing the SOS side button.

Voicemail Guidelines

We advise emergency contacts to switch off any voicemail facility on their phone to prevent delays in reaching help.

However, the following safe-guards are used if a voicemail is reached:

- The wearer can end the current call by clicking the SOS button displayed on the touchscreen or the calling sequence will continue when the voicemail automatically disconnects.

How Contacts Can Call Your Device

An emergency contact can call back to the watch when it is not in alert mode.

Simply dial the contact number of the device (starts with Swedish prefix +46).

Getting a GPS Fix

To get an initial GPS fix, go outdoors or near a window so the watch can get a fix on the satellites. This could take a few minutes depending on your environment.

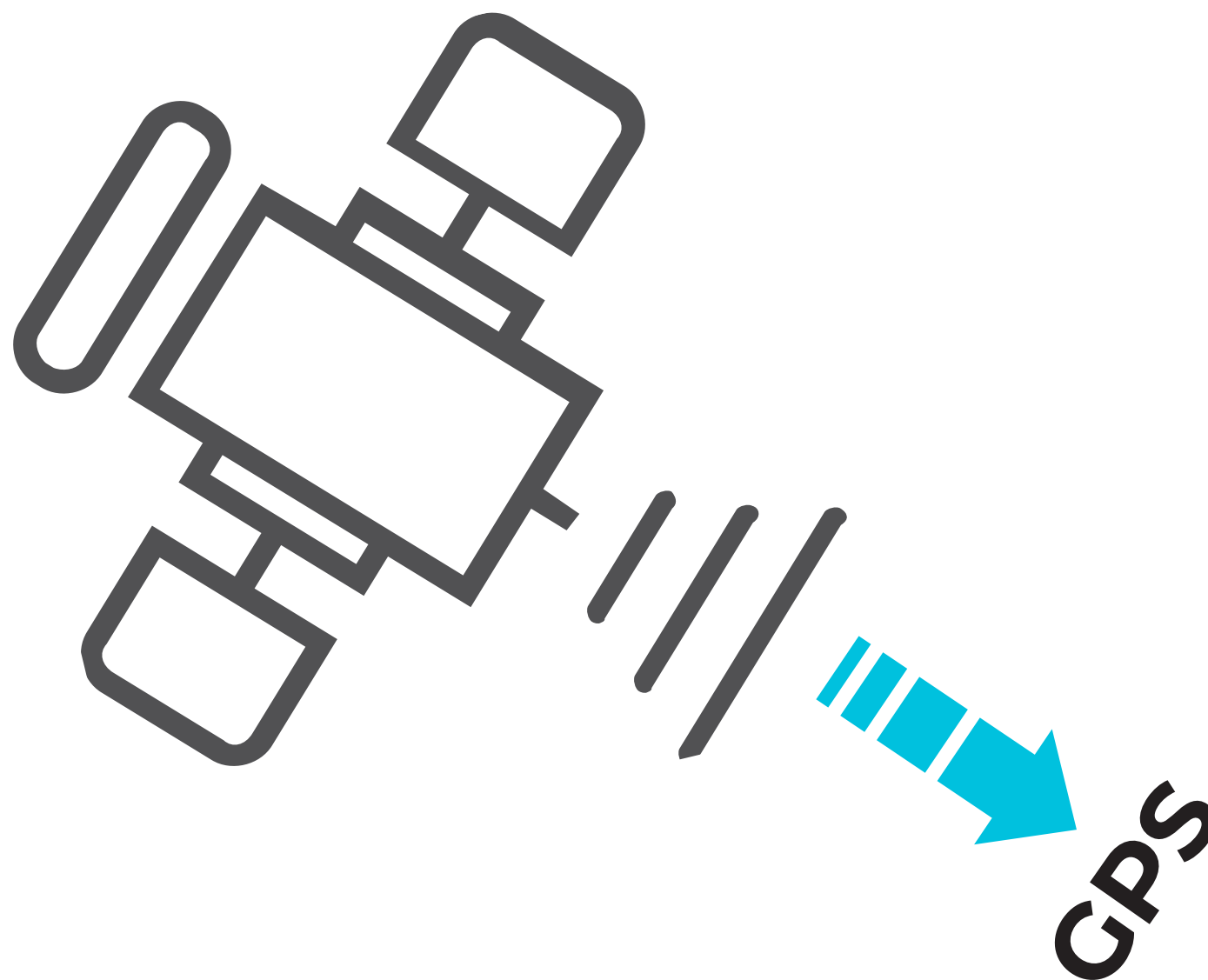

TIP GPS functionality may be unavailable or inaccurate in some locations (e.g. inside buildings, near tall buildings or features or underground).

The watch also provides WiFi and LBS positioning. When GPS is unavailable, it will switch to WiFi and LBS for locating.

The home WiFi and beacons provide additional positioning information to optimize watch battery life.

Please note that WiFi and LBS tracking services are not 100% accurate, it can be used to approximate your location only.

Indoor tracking is only available in combination with a BLE (Bluetooth) beacon.

Receiving an Alert

If you are the emergency contact for a person wearing a Zembro Essentials Comfort Watch, the following section describes how to receive and respond to alerts.

You will receive a call from the person sending the alert, as well as an SMS text message and/or an email from the Zembro SafeTrx service, which contains alert information and a clickable link.

Clicking this link opens your phone or PC browser and takes you to a site that gives you the alert details and the latest location of the person pressing the alert.

As a designated emergency contact, you will also be able to acknowledge and close the alert in this link. If one of the contacts does not close the alert via the link, it will be closed automatically with 48 hours.

This alert page updates once per minute, with position of the person when they alerted.

We recommend that you test the alert service when first using a new Zembro Essentials Comfort Watch and save to your favourites the number that calls and texts you, to ensure it can override any do-not-disturb or silent mode that you may set on your phone (e.g. at night-time).

You may need to consult your phone's settings for more details on how to do this.

Replacing The Band On Your Device

Remove a Band

1) Turn over your Zembro Comfort and find the band latches.

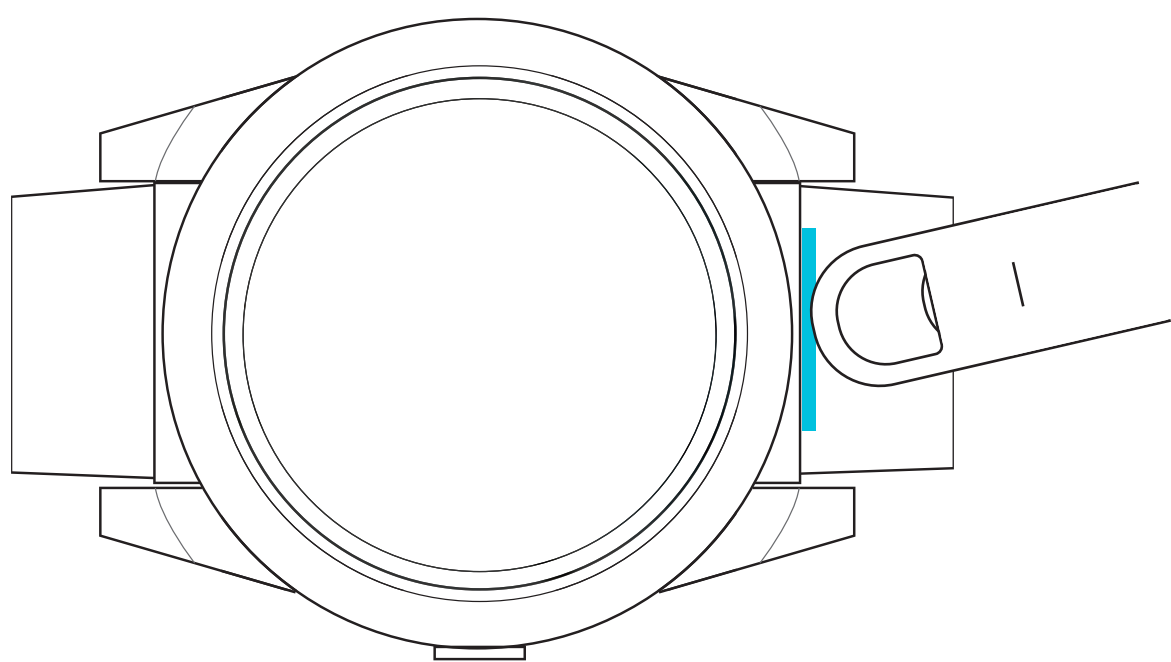

2) To release the latch, slide the flat button toward the band.

3) Gently pull the band away from the watch to release it.

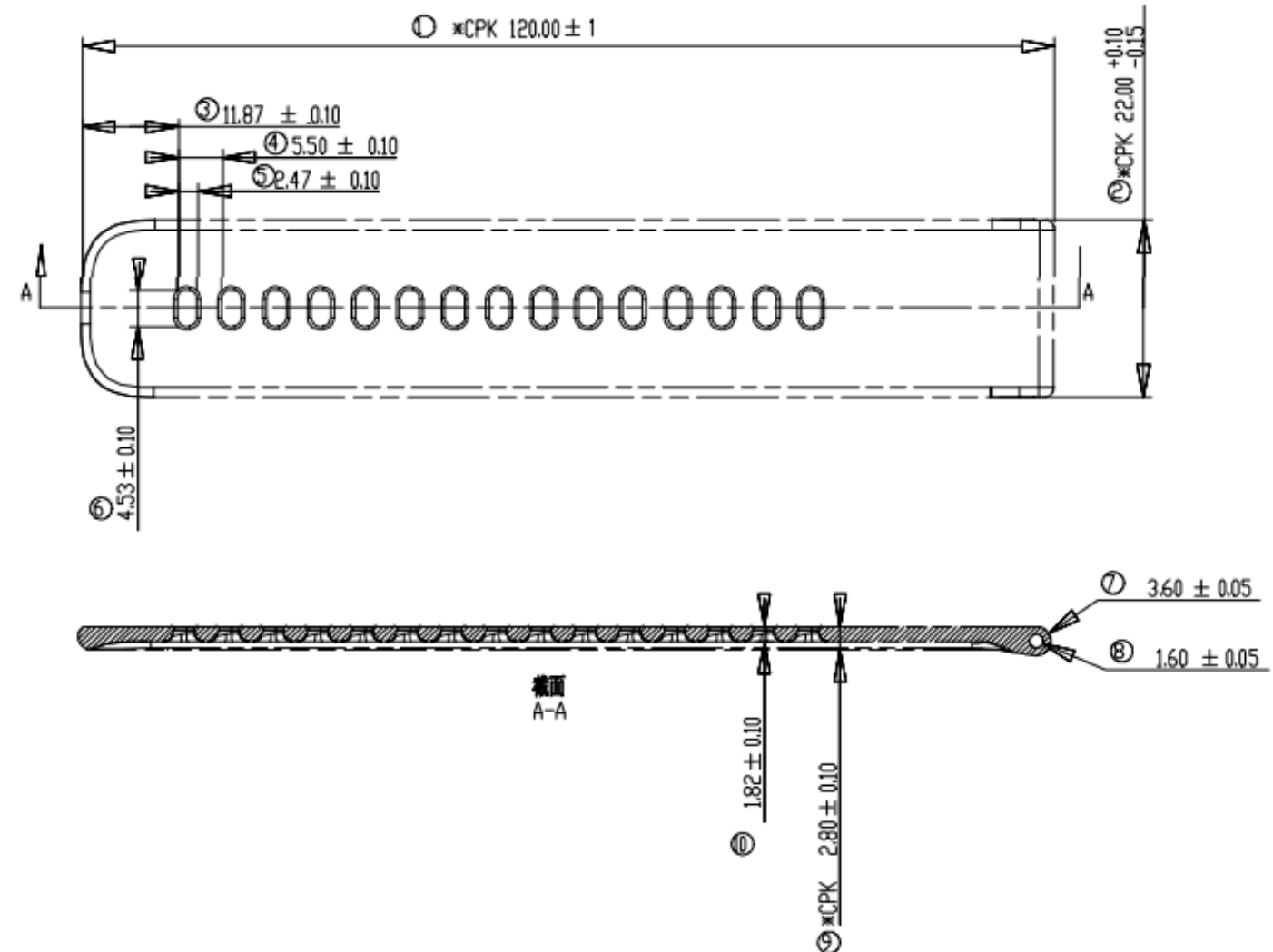
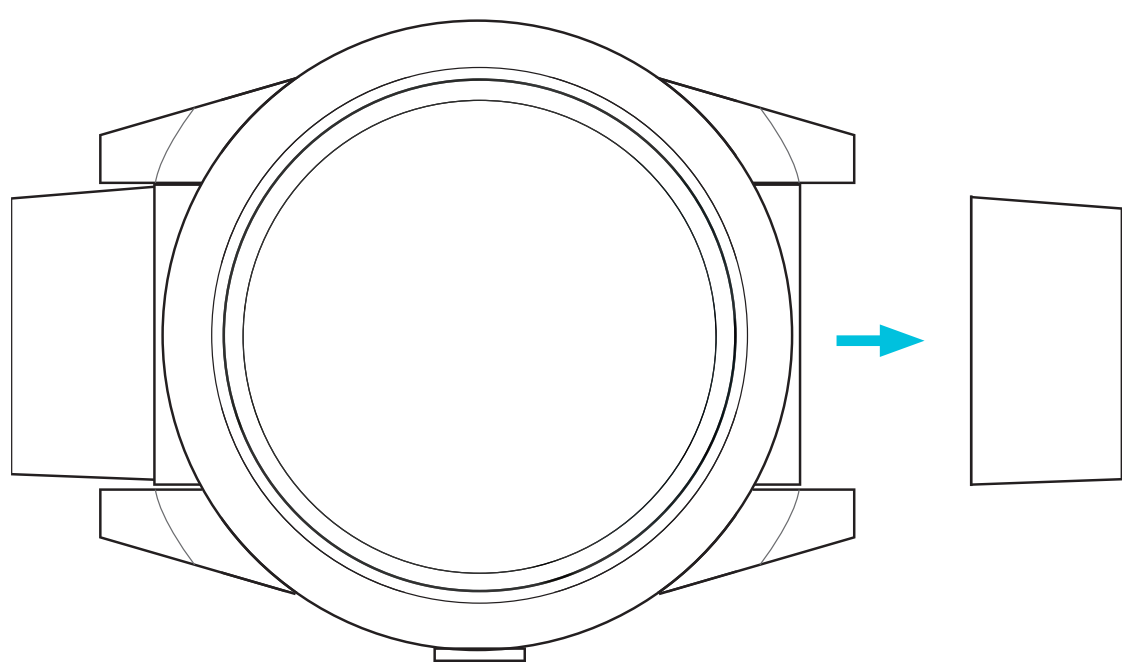

4) Repeat on the other side

Attaching a Band

To attach a band, press it into the end of the watch and slide the latch into place.

Changing your Contact Numbers

If you need to change a contact, add, or delete a contact number, please contact Zembro customer service.

You will be able to make these updates via the Zembro SafeTrx web application (to be launched soon).

Thank you for choosing the Zembro Essentials Comfort Watch.

We wish you many years of protection and peace of mind.

Do not hesitate to contact our customer service if you have queries or problems.

**Peace of mind
with connected health & safety**

zembro.com

Water Resistance

Essentials Comfort and Mini are splash and water resistant but not waterproof. You can, for example, wear and use the device during exercise, in the rain, and while washing your hands, but submerging your device is not recommended.

Comfort and Mini have a water resistance rating of IPX7 under IEC standard 60529.

Water resistance isn't a permanent condition and can diminish over time. Essentials Comfort can't be rechecked or resealed for water resistance.

The following can affect the water resistance of your Essentials Comfort and should be avoided:

- Dropping your Essentials Comfort or exposing it to other impacts
- Exposing your Essentials Comfort to soap or soapy water (for example, while showering or bathing)
- Exposing your Essentials Comfort to disinfectants, perfume, solvents, chlorine, detergent, acids or acidic foods, insect repellents, lotions, sunscreen, oil, or hair dye
- Exposing your Essentials Comfort to high-velocity water
- Wearing your Essentials Comfort in a steam room
- Wearing your Essentials Comfort in a sauna

While the above should be avoided, if your Essentials Comfort accidentally gets exposed to soaps, shampoos, conditioners, lotions, disinfectants, perfumes, solvents, detergent, acids or acidic foods, insect repellent, sunscreen, oil, hair dye, chlorine or any substance other than water, it should be cleaned with pure warm water and dried with a lint-free cloth. Chemicals found in these items could negatively affect water seals and acoustic membranes.

Specifications

Dimensions:	47.5 mm x 16.9 mm
Weight:	65 g
Battery:	Rechargeable, 3.7 V, 580 mAh
Charging voltage:	5 V DC
Water Resistance Rating:	IPX7 (IEC standard 60529)
Locating Technologies:	GPS, BLE, WiFi, LBS

Caution

Please comply with the instructions to extend the watch life:

- Don't use or store the watch in dusty, hot, cold, electric or chemical areas places. Please always keep the watch and accessories dry.
- Don't drop, shake or knock the watch. Rough handling can break it.
- Clean the watch with a dry cloth. Do not use chemical or detergent.
- Don't disassemble or refit the watch as it will void your warranty.
- Using other batteries will cause unwanted situations.
- To avoid accidents, never play with the watch while driving.
- Please turn off the watch in aircrafts and follow any instructions. Wireless devices can cause interference with aircrafts.
- The built-in nano-SIM card can only be used inside the European Union (EU 28).