

# SPIT HC6

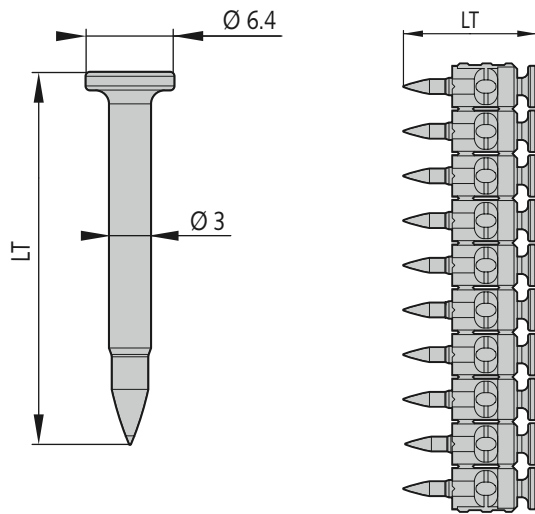

## DESCRIPTION

- Drywall track
- Wiring accessories
- Deflection head application by using HC6-50 to HC6-65 pins (Fixings of gypsum pannel and metal track)
- May be installed in all the direction : floor, wall, overhead
- Adapted for hard material to improve the success rate

## PROPERTIES MATERIAL

### Shank in carbon steel

- Total length Lt: 15, 17, 22, 27, 32, 50, 57,65 mm
- Orange collated strip
- Mechanical zinc plating, min zinc coating 10 µm
- Hardness ≥ 56 HRC

## TOOLS

PULSA P27E - P27P	for HC6-15 to HC6-27
PULSA P40E - P40P - P40P+	for HC6-15 to HC6-32
PULSA P65	for HC6-15 to HC6-65
PULSA P800E - P800P - P800P+	for HC6-15 to HC6-32

## AGREEMENT

- CSTB Technical approval 3.1/22 - 1062
- ETA 22/0439 (P40P+, P65)
- Fire test report GS 6.1/22-002-1

## PIN LENGTH SELECTION

HC6 range	Length shank	Orange strip 500 pcs/box
HC6-15	15	057550
HC6-17	17	057551
HC6-22	22	057552
HC6-27	27	057553
HC6-32	32	057554
HC6-50	50	057701
HC6-57	57	057702
HC6-65	65	057703

## CHARACTERISTIC AND RECOMMENDED LOADS FIRE RESISTANCE

Base material	H <sub>nom</sub> (mm)	Characteristic resistance (kN)		Recommended load (kN)	
		N <sub>Rk</sub>	V <sub>Rk</sub>	N <sub>Rec</sub>	V <sub>Rec</sub>
Non-cracked concrete	15	0.87	0.75	0.30	0.25
	18	1.19		0.40	
	20	1.41		0.47	
Cracked concrete	15	0.05	0.05	0.023	0.023
Steel	6.5	2.58	3.6	1.03	1.2
	7.5	2.91		1.16	
	8.5	3.24		1.30	
	9.5	3.57		1.43	
	10	3.74		1.49	

Base material	HC6 length	H <sub>nom</sub> (mm)	Characteristic resistance under fire exposure (kN)			
			N <sub>Rk,fi</sub> 30 min	N <sub>Rk,fi</sub> 60 min	N <sub>Rk,fi</sub> 90 min	N <sub>Rk,fi</sub> 120 min
Non-cracked concrete	HC6-27	18	0.13	0.10	0.075	0.06
	HC6-32 to HC6-65	15	0.06			
Cracked concrete	HC6-27 to HC6-65	15	0.013			0.01

$N_{Rd,fi} = N_{Rk,fi} / Y_{M,fi}$  usually the safety factor under fire exposure  $Y_{M,fi} = 1$ .

## APPLICATION LIMIT

Concrete : C20/25 to C50/60

Prestressed - Prefabricated concrete

Steel

Thickness of base material (mm)

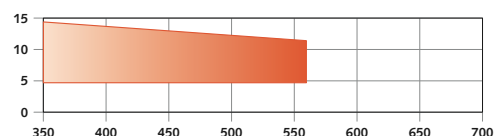

(1) E24	E28	E36	A60
(2) ST37	ST44	ST52	ST60
(3) S235	S275	S355	E335

(1) French designation - (2) German designation  
(3) Designation according to European standard NF EN 10027-1

Ultimate tensile strength of base material (N/mm<sup>2</sup>)