

















INSTRUCTION

OF PREPARING THE WALLS
AND WALLPAPERING

BE SURE TO READ THE INSTRUCTIONS
BEFORE YOU PROCEED TO INSTALLATION

TABLE OF CONTENTS

	Squeegee
	Brush roller
	Knife
	Ladder
	Painting tape
	Small brush
	Small rubber roller
	Measure
	Level/ laser level
	Painting tray
	Straightedge
	Pencil
	Dry pastels
	Good mood

1. General information	4
1.1 What do you need to know before installation?	4
1.2 Do you have any concerns? Contact us	4
2. Vinyl wallpaper on fleece (all structures)	5
2.1 Where can I use structural vinyl wallpaper on fleece?	5
2.2 Preparing the walls	5
2.3 Butt joining	6
2.4 Installation for double cutting	8
2.5 Care	9
3. Aqua Zone – Grid vinyl wallpaper + set of chemicals	10
3.1 Where can I use it?	10
3.2 Preparing the walls	10
3.3 Waterproofing	11
3.4 Wallpapering	11
3.5 Impregnation	12
3.6 Care	13
4. EXTREME Laminated vinyl wallpaper – self-adhesive	14
4.1 Where can I use it?	14
4.2 Preparing the walls	14
4.2.1 Surfaces such as: plaster, concrete, gypsum	14
4.2.2 Surfaces such as glass, lacobel, furniture board, tiles - only smooth, with no raised decors.	15
4.3 Installation	15
4.3.1 Vertical installation	15
4.3.2 Horizontal installation in the kitchen	17
4.3.3 Installation on tiles in a wet zone	18
4.4 Care	18
5. Canvas Sticker – Wallpaper in the shape of a circle	19
5.1 Application	19
5.1.1 Surfaces such as: plaster, concrete, gypsum	19
5.1.2 Surfaces such as glass, lacobel, furniture board, tiles – only smooth, with no raised decors.	19
5.2 Installation of wallpaper in a circle	20
5.3 Care	20
6. Satisfaction guarantee	21
7. Complaints	21

1. GENERAL INFORMATION

Our ultimate goal is to design, manufacture and deliver a beautiful, functional and quality product. We recommend the use of professional installation teams.

CHECK THE WALLPAPER BEFORE INSTALLATION – If anything raises concerns – see chapter 7.

1.1 WHAT DO YOU NEED TO KNOW BEFORE INSTALLATION?

Read the instructions



this will allow you to avoid many mistakes, damaging the wallpaper, and thus, disappointment with the final effect.

Check on the material



choose the relevant chapter from the instructions on how to prepare the wall, perform the installation and care for a specific type of wallpaper.

Check the wallpaper



pay attention to the matching of the pattern, colour scheme and accuracy of the order. If anything raises concerns – **DO NOT INSTALL THE WALLPAPER** (installation excludes the possibility of making a complaint – see chapter 7 – or use the Satisfaction Guarantee – see Chapter 6).

Note! If you do not have enough space to spread the entire wallpaper on the floor at once, it is sufficient to carefully check one strip at a time. Make sure that the colour matches, the pattern connects, and the wallpaper is without defects. If anything raises concerns at this stage, we recommend taking pictures and contacting our customer service immediately.

1.2 DO YOU HAVE ANY CONCERNS? CONTACT US

Call **+48 739 00 44 88** or write an email to **office@wallart.eu** – we will answer on the next working day at the latest. We will be happy to help and resolve your concerns. Our goal is your satisfaction!

Additional information can also be found on our website in the FAQ section.

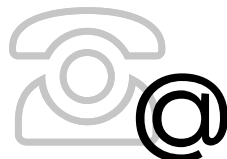

2. VINYL WALLPAPER ON FLEECE (ALL STRUCTURES)

2.1 WHERE CAN I USE STRUCTURAL VINYL WALLPAPER ON FLEECE?

The structural vinyl wallpaper on fleece is adapted exclusively for use inside, in any type of room, including in the bathroom near the sink or free-standing bathtub (without shower option). **It cannot be used** in a sauna area, in the shower, in a cooking zone and in the case of bathtubs directly adjacent to a wall. For surfaces on which water is directly splashed, so-called wet zones, we recommend the AQUA ZONE system, and for a cooking zone – EXTREME material.

2.2 PREPARING THE WALLS

- ▶ The wallpapered wall should be:
 - **Perfectly smooth** – the wallpaper will not hide the irregularities of the wall, but even emphasize them.
 - **Twice primed** with deep penetrating primer Ceresit CT17 at intervals of 24 h. The wall is properly primed if after soaking its surface does not change colour. **Note!** We do not use priming paint, nor do we add primer to paint.
 - **A previously painted** wall should also be primed with a deep penetrating primer. We do not use priming paint, nor do we add primer to paint. Note! Latex, ceramic, oil paints, etc. should be matted with sandpaper before priming.
- ▶ Skirting boards, window frames, door frames and other wooden, stone or metal elements should be covered with acrylic and thoroughly washed. Acrylating the surface after wallpapering can damage it!
- ▶ Light switches and sockets should be installed without holders. Holes for lighting and pictures should be drilled before installing the wallpaper.
- ▶ Radiators should be removed.
- ▶ Furniture should be moved at least 1 metre away from the wallpapered wall.
- ▶ Remove anything from the wall that may interfere with the installation.
- ▶ Wallpapering should take place at the very end of construction works, and the room where we install wallpaper should be cleaned. During the application and 24 hours after, do not ventilate the room, use air conditioning or cause drafts or rapid temperature changes.

2.3 BUTT JOINING

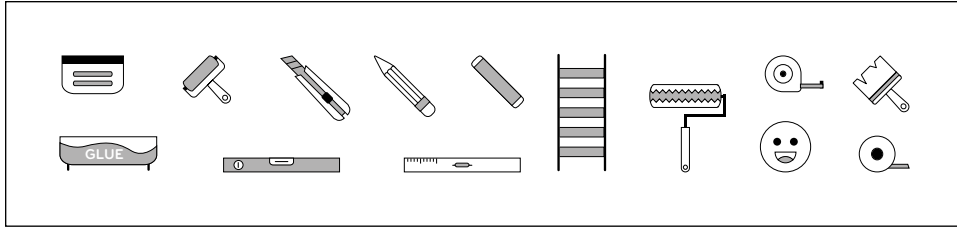

RECOMMENDED ADHESIVE
- WALLFIX HEAVY

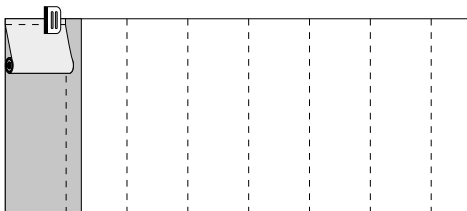
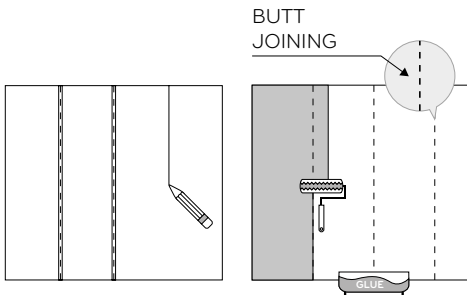
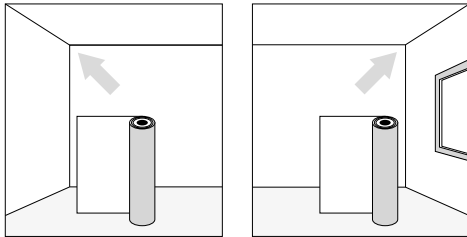

1. Start installing the wallpaper from the left corner of the room or from the window to the door.
2. To make sure that you stick the panels evenly, you can measure and draw vertical lines on the wall about 2 cm narrower than the width of the wallpaper or use a laser level.
3. Apply the adhesive **only** on the wall, on the width of one panel in the direction of installing the wallpaper. Use a roller to apply. Wallpaper panels should be installed on the wall using a **roller** or **wallpaper squeegee**. Remove the excess adhesive from between the panels in points (do not rub).
4. Apply the wallpaper from top to bottom or from bottom to top and smooth with a specialized **squeegee**.
5. Each wallpaper contains 5 cm reserve on the extreme edges. When starting to stick, be sure to fold and not stick the top reserve (if sticking from the top) or the bottom reserve (if installing from the bottom).
6. Smooth the wallpaper from the centre to the edge to push out any air bubbles and excess adhesive.

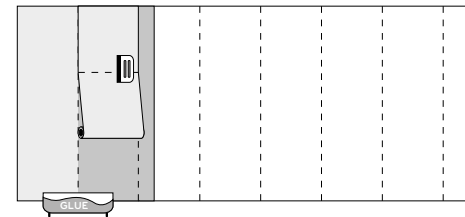
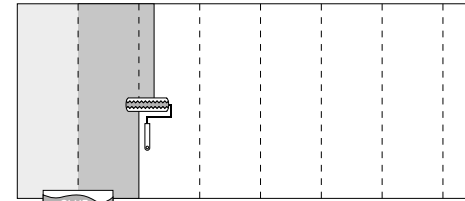
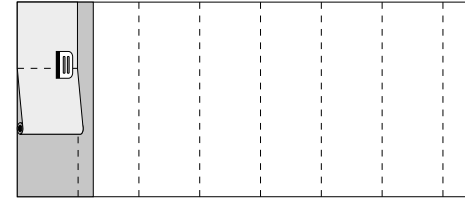

7. The wallpaper must adhere evenly to the surface of the wall at every place.
8. Do not move the stuck wallpaper, as this may damage it. If the location is not precise, peel it off and repeat the application.
9. After installing the first panel, apply the adhesive on the wall to the width of the next panel and start sticking it. Only after sticking the second panel cut off the excess from the top of the wallpaper from the first panel. This ensures that the freshly applied adhesive remains free of dirt.
10. Immediately after installation the wallpaper may be soaked with adhesive, which makes it more delicate and more susceptible to damage. After drying, it will regain its properties.
11. In order to avoid the edges of the wallpaper from showing up on dark patterns, you can mask them with dry pastels after installation.
12. The wallpaper should dry slowly, at a constant temperature, for a few days. During drying, avoid sudden cooling and heating of the room. Do not ventilate the room for a minimum of 24 h.

Note! Some time after the application small air bubbles may appear on the wallpaper as a result of contraction and expansion of the wall or as a consequence of primer that is not fully dried. This is a normal phenomenon. The bubbles should be punctured and filled with adhesive using a syringe.

2.4 INSTALLATION FOR DOUBLE CUTTING

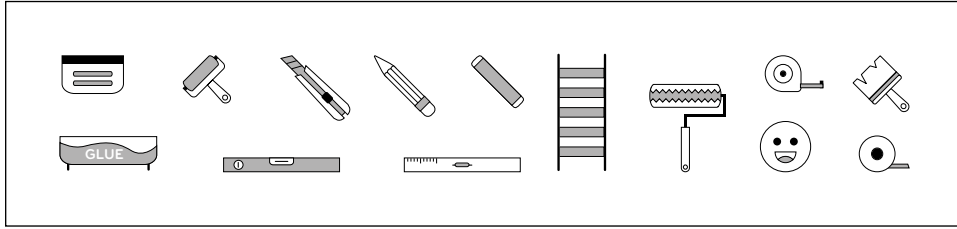

RECOMMENDED ADHESIVE
- WALLFIX HEAVY

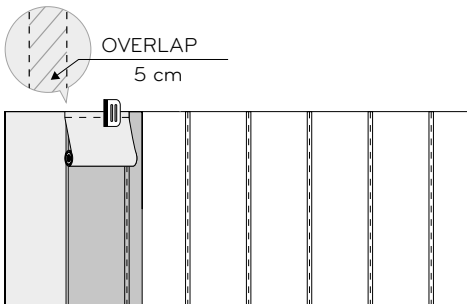
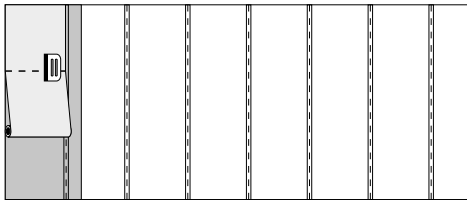
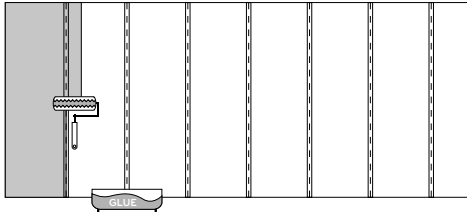

1. Apply points 1-6 of the instructions in section 2.3.
2. Double-cut installation differs only in the method of joining the panels of the wallpaper, the rest of the operations are performed in the same way as during the butt joint installation.
3. In the case of overlapping wallpapers, **remember to apply a little less adhesive** to the places where the panels join.
4. Apply the first panel of wallpaper without pressing the tangent edge. Apply another panel on the first "overlap", so that the edge of the second panel overlaps about 5 cm on the first, and the pattern merges.
5. After sticking the second panel, cut the overlap, with the aid of a ruler, and preferably with a level.

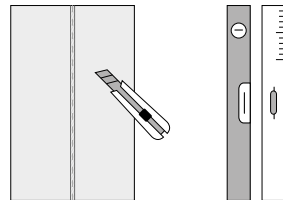

6. Cut approximately in the middle of the overlap using a sharp knife that guide you at an angle of 35 degrees. Cut two layers of wallpaper at the same time, taking care not to cut the wall. You can also use a knife with a guide for professional double cutting.
7. After cutting the overlap, remove the cut pieces of panel No. 2 and No. 1. If the edges of the panels need to be stuck, you can gently lift them up and lightly apply adhesive.
8. Connect the edges, remembering to remove the adhesive from under the wallpaper in points, without rubbing locally. **Use a damp cloth** to avoid damaging the adhesive-soaked wallpaper.
9. Combine the other panels in the same way until you get a full picture on the wall. Double cutting allows you to make perfect, practically invisible joints between pieces of wallpaper.
10. In order to avoid the edges of the wallpaper from showing up on dark patterns, you can mask them with **dry pastels** after installation.
11. **The wallpaper should dry slowly, at a constant temperature, for a few days.** During drying, avoid sudden cooling and heating of the room. Do not ventilate the room for a minimum of 24 h.

Note! Some time after the application small air bubbles may appear on the wallpaper as a result of contraction and expansion of the wall or as a consequence of primer that is not fully dried. This is a normal phenomenon. The bubbles should be punctured and filled with glue using a syringe.

2.5 CARE

After drying, the vinyl wallpaper on fleece is fully washable and resistant to splashes and household dirt. The wallpaper can be gently washed with a cloth or the soft side of a sponge soaked in water and with a delicate detergent such as soap or washing-up liquid. Do not scrub or use harsh, corrosive chemicals.

3. AQUA ZONE

– GRID VINYL WALLPAPER

+ SET OF CHEMICALS

3.1 WHERE CAN I USE IT?

Use only in a wet zone - where water is splashed directly on the wall. DO NOT SKIP ANY STEP OR USE CHEMICALS OTHER THAN THOSE DESCRIBED IN THE INSTRUCTIONS

The comprehensive installation of the Aqua Zone system consists of 4 stages:

- 3.2. Preparing the walls
- 3.3. Waterproofing
- 3.4. Wallpapering
- 3.5. Impregnation

All necessary chemical preparations used for priming, waterproofing, wallpapering and impregnation are included in the Aqua Zone kit.

The preparations have the highest effectiveness when they are fresh, we recommend ordering them a few days before installation, so that they do not degrade due to the storage time.

You will need:

- mixing blade
- microfiber roller for painting, hair medium width 25-27 cm
- Wall Motion roller for lacquers x2 we recommend 15 cm wide
- painting tray
- painting tape
- angled brush
- small brush with a width of about 2 cm
- block paintbrush
- bucket
- paint foil for protection

3.2 PREPARING THE WALLS

The surface to be primed should be properly prepared, which ensures proper absorption of the primer:

- the wall should be even, smooth, washed and dust-free
- corners with sharp finish (no rounding)
- residues of earlier paints or wallpaper thoroughly removed
- any imperfections such as cracks, holes, gaps filled

For the correct application of the primer you need a block paintbrush and a bucket. Rub the primer **[bottle: 1. Primer]** firmly into the wall with a brush. After the application is completed, the wall should be left to dry. This is a necessary condition to move to the next stage of preparation. After 12h you can go on to waterproofing.

3.3 WATERPROOFING

Make sure that the wall is smooth before starting work. Any irregularities, not only will not be hidden, but even highlighted after the application of waterproofing, and then wallpaper.

Layer 1

1

To perform waterproofing prepare the appropriate substance **[bottle: 2. Waterproofing - layer 1].**

Apply the preparation very generously using a brush, pay special attention to:

- corners
- the area around the edges of tiles
- pipes coming out of the wall
- any possible places where there may be the smallest gap through which water can potentially penetrate and can lead to the rotting of the wallpaper.

Layer 2 (applied after 6h)

2

For the application of the second layer, use a separate preparation **[bottle: 3. Waterproofing - layer 2].**

Pour the product directly into a painting tray or bucket and apply with a brush or roller.

During drying, the conditions in the room should remain stable, i.e. we do not ventilate the room, do not heat it, leave the ventilation open so that any moisture can escape. The surface is ready after about 48 h, the exact time depends on such factors as temperature, air humidity and absorption of the substrate.

The finished wall should be in a uniform colour and should not be sticky to the touch.

3.4 WALLPAPERING

1. Start wallpapering **at least 48 hours** from the application of the waterproofing layer.
2. Start by checking whether the dimensions of the wallpaper are appropriate and whether everything is in accordance with the order.
3. Place adjacent panels of wallpaper on a flat surface, in order to check whether the pattern is printed correctly and there is no colour difference between the panels.
4. The next step is to check whether the wall is dry and completely covered with waterproofing. If the wall does not have a uniform colour, there are any colour differences, this means that the wall is still wet and you should wait.
5. In contrast to the installation of wallpaper in dry rooms, in the case of the wet zone, the panels should be laid **1-2 mm** from the edge of the wall (bottom, top and side) so that at the stage of impregnation it will also cover the edges of the wallpaper.

6. Another difference is the installation of wallpaper around pipes protruding from the wall, especially if there is a pipe on which a shower unit is installed. You should check how far the rosettes will reach and cut a circle of 5 mm smaller than their circumference, so as to move the wallpaper away from the pipe as much as possible.
7. In the case of a wet zone, it is not important from which side you will start wallpapering, you can choose whichever way is most convenient. Before you start applying the adhesive – determine the vertical and measure where the joint of the panels will fall. Using a laser pointer will make these tasks very easy. Roll out the wallpaper with the pattern to the centre, so that the top of the wallpaper is the beginning of our roll.
8. Apply the adhesive [**bottle: 4. Aqua zone glue**] to the wall on the width of one panel plus about 5 cm in the direction of installing the wallpaper. For application use a long haired painting roller, and at the edges even out the excess adhesive with a brush (we recommend angled brushes with synthetic hair).
9. Each wallpaper contains 5 cm reserve on the extreme edges. Start sticking

from the top, remembering to fold and not stick the top reserve.

10. After installing the first panel, apply the adhesive on the wall, on the width of the next one and start sticking it. Only after sticking the second panel cut off the excess from the top of the wallpaper from the first strip. This ensures that the freshly applied adhesive remains free of dirt.
11. After installing the whole wallpaper, move on to cleaning. If painting tapes have been used, they must be removed.
12. Check whether any bubbles have appeared during installation.
13. At this stage, we also recommend to make detailed photo documentation of the placed wallpaper, with particular emphasis on the joints and edges of the wallpaper and on the protrusions.

Note! During the drying of the wallpaper, we do not allow drafts or changes in humidity. Installation should take place when the room already has doors installed, which we will not regularly open. The temperature of the room should not be less than 16 degrees.

3.5 IMPREGNATION

1. Start the impregnation of the wallpaper at least **48 hours after sticking the wallpaper**. Before starting, carefully check the following:
 - whether the wallpaper is well stuck,
 - whether any bubbles have formed,
 - whether any corner is peeling off
 - whether the adhesive has actually bound the wallpaper to the substrate
2. If you find that the adhesive under the wallpaper is still wet, put off the impregnation until it dries.
3. The tools needed to perform impregnation are:
 - Wall Motion roller for lacquers
 - small brush with a width of about 2 cm
 - painting tray
 - painting tape

4. Both the roller and brushes will be disposable, so prepare two sets. Elements adjacent to the wallpaper are worth covering with painting tape, this will facilitate the distribution of the product at the edges.
5. Mix the impregnation ingredients together [**bottles: 5. Impregnation A - layer 1 and 6. Impregnation B - layer 1**] in a 10:1 ratio. Because of the fact that the impregnation dries quickly, we recommend mixing no larger amount than needed for 5-6 m². Volume ingredients are prepared individually for each order so that there is enough to cover specific wallpaper surface.
6. When you have the finished product in the painting tray, start by impregnating the edges of the wallpaper with a brush. Thoroughly apply to all the edges of the wallpaper and impregnate those places that you will not reach with a roller. The next step is to distribute the impregnate with a roller over the entire wallpaper.
7. After the impregnation is finished, remove the tapes and monitor the wall for about a quarter of an hour, making sure that no drips are formed. If there is a drip, it should be gently rolled out to remove the excess impregnate.
8. Mix the ingredients needed for the second layer together [**bottles: 7. Impregnation A - layer 2 and 8. Impregnation B - layer 2**] similarly to point 5.
9. Apply the second layer of impregnate after about 8-12 h, but not later than 24 hours.
10. Installation of Aqua Zone systems is considered to be completed after 72 hours after the last impregnation. Then you can also proceed to the installation of dispensers, handles, etc. on the wall.
11. Protect the edges of the installed components with Sikaflex sealant. The bathroom can be used after the sealant has cured (according to the recommendations on the packaging).

*If the place where the wallpaper meets tiles is irregular, it is recommended to protect the edge of the wallpaper with Sikaflex sealant.

** If grouting is necessary, we recommend the use of epoxy grout.

3.6 CARE

1. After bathing, the wallpaper should be rinsed, especially if we suspect that it may have splashed soap or shampoo onto it. In rooms with low air circulation, it is also recommended to wipe the wallpaper with a soft cloth to remove drops of water from the surface of the wall.
2. Once a week, wash the wallpaper with a special cellulose sponge for grout and a delicate washing-up liquid.
3. It is strictly forbidden to scrub the wallpaper with rough scourers or to use the following agents:
 - vinegar
 - citric acid
 - baking soda
 - harsh chemicals designed for washing bathrooms

4. EXTREME LAMINATED VINYL WALLPAPER - SELF-ADHESIVE

4.1 WHERE CAN I USE IT?

- For installation in a cooking zone, on the wall, lacobel, glass, smooth tiles, furniture board.
- For installation on furniture - cabinets, chests of drawers, desks, coffee tables, tables, furniture fronts.
- On walls in extremely difficult places prone to dirt and in bathrooms on a raw wall in the dry zone or in the shower on tiles, glass or plexiglass.

4.2 PREPARING THE WALLS

4.2.1 SURFACES SUCH AS: PLASTER, CONCRETE, GYPSUM

- ▶ The wallpapered wall should be:
 - **Perfectly smooth** - the wallpaper will not hide the irregularities of the wall, but even emphasize them.
 - **Twice primed** with deep penetrating primer Ceresit CT17 at intervals of 24 h. The wall is properly primed if after soaking its surface does not change colour. **Note!** We do not use priming paint, nor do we add primer to paint.
 - **A previously painted wall** should also be primed with a deep penetrating primer. We do not use priming paint, nor do we add primer to paint. Note! Latex, ceramic, oil paints, etc. should be matted with sandpaper before priming.
- ▶ Wallpapering should take place at the very end of construction works, and the room where we install wallpaper should be cleaned. During the application and 24 hours after, do not ventilate the room,
- ▶ use air conditioning or cause drafts or rapid temperature changes.
- ▶ Remove anything from the wall that may interfere with the assembly.
- ▶ Skirting boards, window frames, door frames and other wooden, stone or metal elements should be covered with acrylic and thoroughly washed. Acrylating the surface after wallpapering can damage it!
- ▶ Light switches and sockets should be installed without holders.
- ▶ Holes for lighting and pictures should be drilled before installing the wallpaper.
- ▶ Radiators should be removed.
- ▶ Furniture should be moved at least 1 metre away from the wallpapered wall.

4.2.2 SURFACES SUCH AS GLASS, LACOBEL, FURNITURE BOARD, TILES - ONLY SMOOTH, WITH NO RAISED DECORS.

- ▶ When installing on tiles with classic, deep joints, for a better visual effect, we recommend levelling the joints with putty and priming the putty surface. After the primer has dried - the whole should be degreased and dusted.
- ▶ Clean and degrease the surface for sticking so that it is clean and free of dust.

4.3 INSTALLATION

Note! The wallpaper requires installation on an overlap, which **MUST NOT BE CUT**. The overlap must remain on the wall, because the material will shrink slightly. If the overlap is cut, after 2 weeks a gap of about 1-2 mm will be formed. This is a natural process for a material consisting of 100% vinyl.

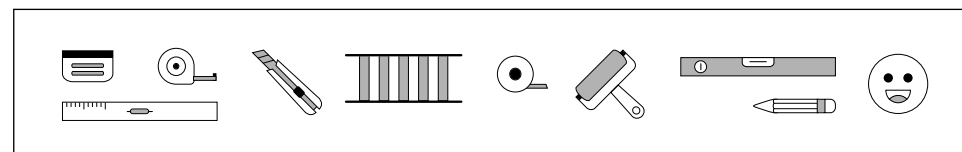

4.3.1 VERTICAL INSTALLATION

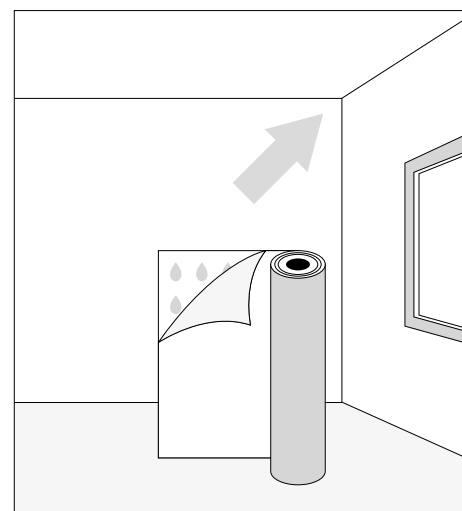

1. If the wallpaper consists of more than one piece, start the application from the window to the door.
2. Use a squeegee for installation. If you do not have a squeegee, you can use a payment card wrapped in a cloth.
3. The wallpaper is self-adhesive, consisting of 2 layers - vinyl with adhesive and backing paper.
4. The wallpaper has a two-component adhesive with a droplet structure, so that the air easily comes out from under the wallpaper during application and no air bubbles are formed. If they arise, it is sufficient to smooth them out with your hand, without the need to puncture the surface.

- The first adhesive is a contact adhesive with a low adhesive strength, which makes it possible to repeatedly remove the wallpaper during installation and make possible corrections. The main-permanent adhesive is activated 24 hours after the application and pressing the wallpaper onto the substrate.
- During installation the wallpaper can be repeatedly removed and stuck again. However, care should be taken not to stretch it! After sticking on the wall of the whole, we do not recommend removing the entire wallpaper and sticking it onto

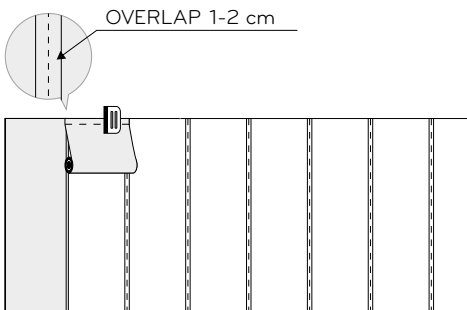
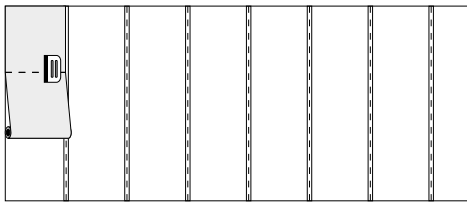
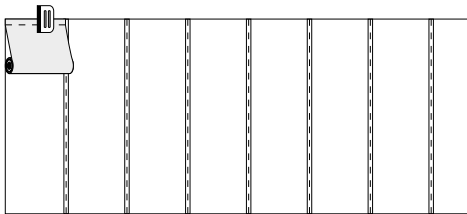

another place, especially when there is a need to lay more than 1 panel.

- NOTE** when installing on an overlap, never under any circumstances cut the overlap. It must remain on the wall, because the material will shrink. If the overlap is cut, after 2 weeks a gap of about 1-2 mm will be formed – this is a natural process for 100% vinyl. The graphics are prepared in such a way that the pattern connects after applying one panel onto another by approx. 2 cm.
- Start installation by removing 10 cm of backing paper and applying the top edge of the wallpaper by pressing the surface of the wallpaper with a squeegee on the wall and checking whether its length is sufficient to cover the entire wall and whether it is stuck straight.
- When installing more than one panel of wallpaper, be sure not to start the installation from the top flush with the ceiling – always roll a few cm of reserve from the top.
- Roll out the wallpaper with the pattern to the centre starting from the bottom. Apply from top to bottom and smooth with a squeegee from the centre to the edge to guide out any air bubbles. The wallpaper must adhere evenly and strongly to the surface of the wall at every place.
- To connect the next panels of wallpaper, you need to apply 2 cm of the second panel onto the first. For ease of use, you can ask another person for help or after matching the graphics, stick the installed panel to the wall with painting tape. Be careful not to move the pattern during the application.

- Remove the backing paper evenly, do not pull the entire paper off at once.**
- If the location is not precise, peel it off and repeat the application. Make sure to match the pattern of each strip of wallpaper.
- Note!** Some time after the application small air bubbles may appear on the wallpaper as a result of contraction and expansion of the wall or as a consequence

of primer that is not fully dried. Do not pierce them! Simply press them gently with your hand. If too much time has passed since the application and the pressed wallpaper does not stick to the substrate, gently heat it with a dryer or a heat gun (heating activates the adhesive) and press it again. Be careful not to melt the wallpaper!

- Cut off excess wallpaper with a knife. To do this evenly, use a ruler or a squeegee.

4.3.2 HORIZONTAL INSTALLATION IN THE KITCHEN

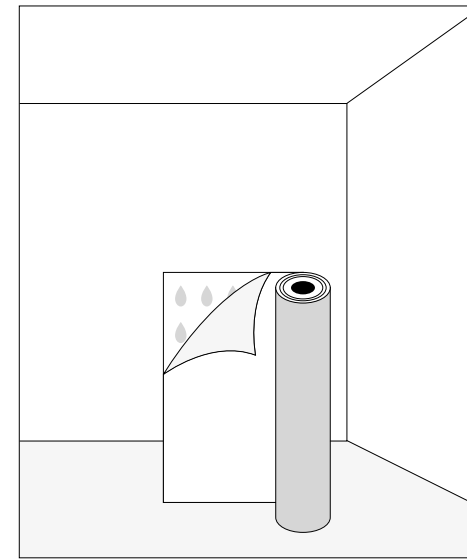

- Use a squeegee for assembly. If you do not have a squeegee, you can use a payment card wrapped in a cloth.
- The wallpaper is self-adhesive, consisting of 2 layers – vinyl with adhesive and backing paper.
- The wallpaper has a two-component adhesive with a droplet structure, so that the air easily comes out from under the wallpaper during application and no air bubbles are formed. If they arise, it is sufficient to smooth them out with your hand, without the need to puncture the surface.
- The first adhesive is a contact adhesive with a low adhesive strength, which makes it possible to repeatedly remove the wallpaper during installation and make possible corrections. The main-permanent adhesive is activated 24 hours after the application and pressing the wallpaper onto the substrate.

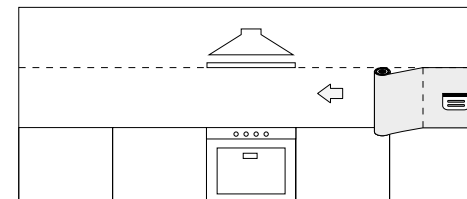

- When installing wallpaper in the kitchen in one horizontal piece, perform the installation from right to left, not from top to bottom.

6. The second option for very long pieces, is installation from the inside of the wallpaper. Remove 10–20 cm of backing paper from the inside and stick the wallpaper evenly to the sides.
7. **Remove the backing paper evenly, do not pull the entire paper off at once.**
8. If the location is not precise, peel it off and repeat the application. Make sure to match the pattern of each strip of wallpaper.
9. **Note!** Some time after the application small air bubbles may appear on the wallpaper as a result of contraction and expansion of the wall or as a consequence of primer that is not

fully dried. Do not pierce them! Simply press them gently with your hand. If too much time has passed since the application and the pressed wallpaper does not stick to the substrate, gently heat it with a dryer or a heat gun (heating activates the adhesive) and press it again. Be careful not to melt the wallpaper!

10. Cut off excess wallpaper with a knife. To do this evenly, use a ruler or a squeegee.

4.3.3 INSTALLATION ON TILES IN A WET ZONE

1. Perform installation as in step 4.3.2.
2. Remember to protect the edges of the wallpaper and the places of installing taps with silicone.
3. Limit the number of holes in the wallpaper to a minimum. We do not recommend installing additional items of equipment such as shelves, soap dispensers, etc. on the wallpaper.

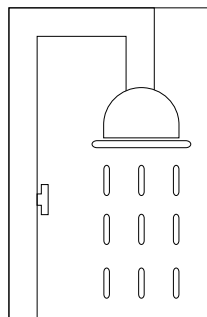

4.4 CARE

Extreme wallpaper is a material laminated at the production stage and as double-layer 100% vinyl it is very resistant. The wallpaper can be washed, scrubbed with the sharp side of a sponge, and if necessary, use harsh cleaning agents. Remember to rinse the wallpaper with water immediately after washing. EXTREME material does not require wiping dry, water flows off it spontaneously, and scale does not form.

5. CANVAS STICKER – WALLPAPER IN THE SHAPE OF A CIRCLE

5.1 APPLICATION

Inside rooms, on any smooth and flat surface, except the floor. Do not use in a cooking zone or directly in a shower.

5.1.1 SURFACES SUCH AS: PLASTER, CONCRETE, GYPSUM

- ▶ The wallpapered wall should be:
 - **Perfectly smooth** - the wallpaper will not hide the irregularities of the wall, but even emphasize them.
 - **Twice primed** with deep penetrating primer Ceresit CT17 at intervals of 24 h. The wall is properly primed if after soaking its surface does not change colour. **Note!** We do not use priming paint, nor do we add primer to paint.
 - **A previously painted wall** should also be primed with a deep penetrating primer. We do not use priming paint, nor do we add primer to paint. **Note!** Latex, ceramic, oil paints, etc. should be matted with sandpaper before priming.
- ▶ Remove anything from the wall that may interfere with the assembly.
- ▶ Wallpapering should take place at the very end of construction works, and the room where we install wallpaper should be cleaned. During the application and 24 hours after, do not ventilate the room, use air conditioning or cause drafts or rapid temperature changes.

5.1.2 SURFACES SUCH AS GLASS, LACOBEL, FURNITURE BOARD, TILES – ONLY SMOOTH, WITH NO RAISED DECORS.

- ▶ When installing on tiles with classic, deep joints, for a better visual effect, we recommend levelling the joints with putty and priming the putty surface. After the primer has dried – the whole should be
- degreased and dusted.
- ▶ Clean and degrease the surface for sticking so that it is clean and free of dust.

5.2 INSTALLATION OF WALLPAPER IN A CIRCLE

1. Start the application from the top, peeling off the first 10 cm of the circle from the paper backing layer.
2. Do not pull off the backing paper completely, it will make the application much more difficult.
3. The first 10 cm of backing paper can be cut off with a knife or folded so that it does not interfere with the sticking of the top of the circle to the substrate.
4. Stick the top of the wallpaper circle, see if the location is as you expect and proceed to further work.
5. Use a squeegee for installation. If you do not have a squeegee, you can use a payment card wrapped in a cloth.
6. Roll up the unstuck part of the wallpaper with the graphics inside into the roll, and then start removing the backing paper and sticking the wallpaper evenly to the substrate.
7. Apply from top to bottom and smooth with a squeegee from the centre to the edge to guide out any air bubbles. The wallpaper must adhere evenly and strongly to the surface of the wall at every place

8. Perform the action slowly, put in place, smoothing with a squeegee or payment card from the centre to the sides. Take your time in order to avoid air bubbles appearing under the wallpaper.
9. If something does not come out well, during the application you can gently pick up the wallpaper – peel off and improve.
10. To ensure the application goes without problems, do not stretch the wallpaper, allow the material to lie naturally. Your task is only to remove the air from underneath.
11. If air bubbles are formed – you can pierce them with a thin needle and pressing with a squeegee, remove the air.
12. The application should not take more than 10 minutes.

5.3 CARE

The wallpaper circle is washable, resistant to splashes and household dirt. The wallpaper can be gently washed with a cloth or the soft side of a sponge soaked in water and with a delicate detergent such as soap or washing-up liquid. Do not scrub or use harsh, corrosive chemicals.

The wallpaper circle is not suitable for a cooking zone or directly in the shower.

6. SATISFACTION GUARANTEE

Our basic mission is to produce beautiful decorations for your interior. It is very important to us that you, dear customer, will find our product to be beautiful.

Therefore, we are the only company in Poland producing custom-made wallpaper to introduce for our customers a **Satisfaction Guarantee** with the purchase of custom-made wallpaper.

If for any reason, the wallpaper you received does not meet your expectations, you can replace it one time with any pattern from our range, within 14 days of receiving the order. Details and rules of using the **Guarantee** – you will find on our website

Remember, in order to use the **Satisfaction Guarantee** the wallpaper must not be damaged or previously installed and must be sent back to us as a return.

To make use of the **Satisfaction Guarantee**, please contact us by e-mail at: office@wallart.eu, enter the order number and the address from which we will receive the wallpaper. We will deliver the new wallpaper in the same time as the original order (in the same mode).

7. COMPLAINTS

Do not be afraid to make complaints, we are here to help you and give full satisfaction with your purchase. If the wallpaper does not comply with the order, has defects, is incomplete or in any other way raises concerns – DO NOT INSTALL IT, but make a complaint by e-mail to the following address: office@wallart.eu.

Describe the problem, submit the order number, and attach photo documentation. If we need additional information, we will ask you to send us the wallpaper or we will send a courier to the indicated address.

If we accept the complaint, you will receive a new wallpaper from us within 3 working days of its consideration.

If you want to know more about complaints – see the information in the regulations on our website.

Guarantee and complaint terms and conditions

1. The purchased goods are guaranteed – 2 years from the date of purchase.
2. The guarantee includes self-adhesive wallpaper coming unstuck from a properly prepared substrate for laminate self-adhesive wallpaper, including rolling on the edges.
3. For self-adhesive laminated vinyl wallpaper shrinkage of up to 3 mm is a natural element and is not subject to guarantee, unless it causes the separation of larger sections of the wallpaper from the wall.
4. The guarantee also includes loss of colour higher than 5% compared to the colour on the day of installation.
5. The product guarantee does not cover installation or damage caused during

- installation, such as tearing, abrasion, scratches, stretching of the material or improper matching of the panels.
6. The guarantee does not cover mechanical damage to wallpaper in the form of scratches, holes in the wallpaper and wall.
 7. The guarantee does not cover mechanical damage caused by scrubbing and the use of detergents for smooth fleece and vinyl on fleece. The only material resistant to scrubbing is self-adhesive laminated vinyl.
 8. Complaints should be submitted to the e-mail address office@wallart.eu
 9. In the case of defective goods or errors in the execution of the order, the Store guarantees their replacement with undamaged or appropriate goods within 7 working days from the recognition of the complaint.
 10. The products subject to the complaint should be sent back in a package that guarantees good protection against possible damage in transport. It is recommended to mark the package with an annotation regarding the reason for the complaint. After the complaint has been positively processed, the costs of returning the package will be refunded.
 11. Unjustified complaints and damage resulting from improper use of the goods will not be taken into account. Any costs related to such cases shall be borne by the Buyer.
 12. Acceptance of the product card means the final confirmation of the appearance, arrangement, size and proportion of the pattern, as well as confirmation of the selected material, the technique of preparing joints between the strips of wallpaper and the division of the pattern into panels.
 13. Complaints submitted due to the content of the order (e.g. material, pattern, size, installation method) after accepting the product card will not be taken into account.
 14. Each wallpaper before application on the wall should be checked on a flat surface – matching the colour, joints and pattern taking into account the overlap – for self-adhesive laminated vinyl wallpaper. Complaints submitted after sticking to the wall, bypassing the step of checking the wallpaper on a flat surface will not be taken into account. In the case of non-matching of patterns or colours between the panels, complaints should be submitted before the application to the wall – by taking pictures and sending them to the e-mail address at reklamacje@wallart.com.pl
 15. We do not produce metallized wallpaper. The colour of gold, silver and copper is a printed colour, that is, imitating the colour of gold, silver and copper.
 16. Any shipments sent at the expense of Wall Art Sp. z o.o. based in Wrocław will not be accepted.
 17. Individual settings of the end device may cause differences between the visualization of the product on the Customer's computer and the actual appearance of the product (colour, proportions, etc.). This is not the basis for a complaint.
 18. The customer has the right to order a sample to check the texture of the material, colour and quality of the graphics. An A3 sample shows the overall appearance (arrangement and proportions) of the design in a smaller size for 3x4m or 3x5m for collections from 2021, walls and fragment 1:1 for 3x4 m or 3x5m for collections from 2021. It is possible to order a sample in 1:1 for the target wall size, for the customer's explicit order.

The sample is only a fragment of the target wallpaper, which is a mural (not a repeatable pattern). It is not possible for the sample to contain the whole pattern, on the whole wall in a scale of 1:1. A complaint may be based only on a difference between the physical sample and the ordered product, including a specific part of the wallpaper, provided that the wallpaper order occurred within 14 days from the date of receipt of the sample, and the wallpaper check took place immediately after the receipt of the order.

19. Complaints submitted due to colour differences without prior sample order will not be taken into account.
20. The sample is a representative example of the aspect ratio, product quality, material structure, print quality, blur sharpness, colour tone, and the colours for the individual shades that appeared on the sample. If the customer is not able to assess whether the sample meets his expectations for the final effect based on the provided sample, he should ask for a sample of another piece of wallpaper of his choice or cancel the order.
21. Wallpaper above 350 cm in height will be prepared for installation on a double cut.
22. If a fragment or part of the wallpaper has been damaged due to the fault of the customer, it is possible to order a reprint. In the case of reprinting, complaints about colour differences compared to the already produced wallpaper will not be considered



Wallart Sp. z o.o.
wallart.eu
+48 739 00 44 88
ul. Rafała Wojaczka 3f
51-169 Wrocław