

# Industrial Monitors



## Style 605

### Unique Features of Protek Industrial Monitors

- ① Flow turning vanes in each elbow efficiently reduce friction
- ② Powder coating produces a tough, corrosion resistant finish
- ③ Positive friction locks with brass knob for both horizontal and vertical travel to hold desired position
- ④ Stainless steel lever for durability and easy control
- ⑤ Major components made from brass alloy (UNS C83600, ASTM B62) for a long-lasting service life
- ⑥ Available in 2" NPT or 2" BSP threaded inlet and optional flange
- ⑦ Double-row stainless steel ball bearings in monitor joints ensure smooth movements even when the monitor is under pressure
- ⑧ Compatible with Protek's diverse range of water and self-educating foam monitor nozzles for various applications

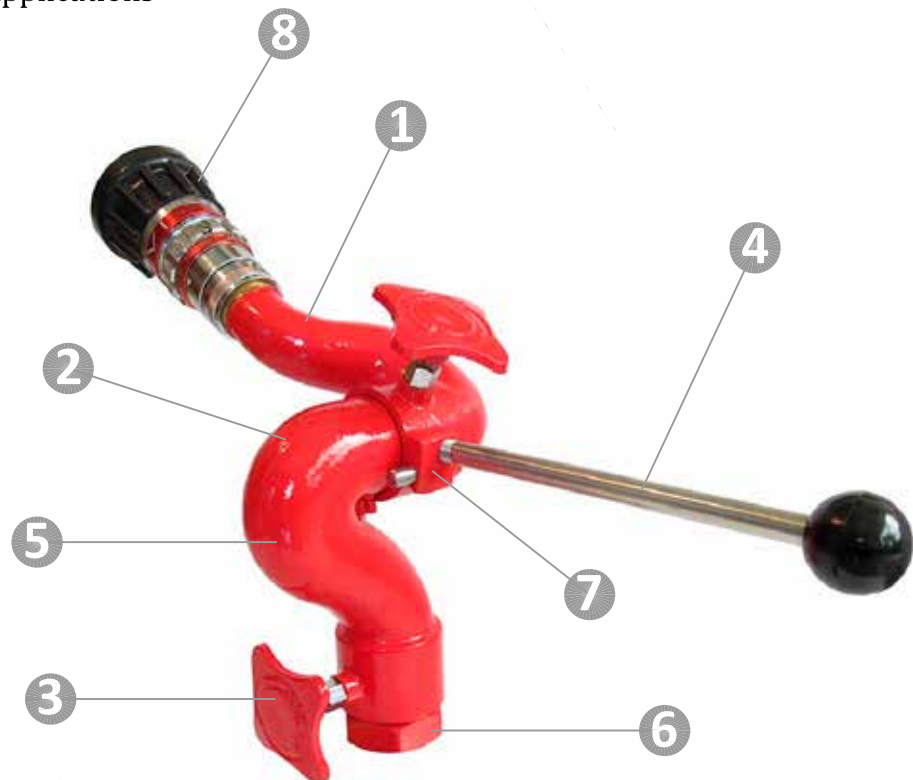

Style 605 monitor shown  
with Style 367-BCTO nozzle

# Industrial Monitors

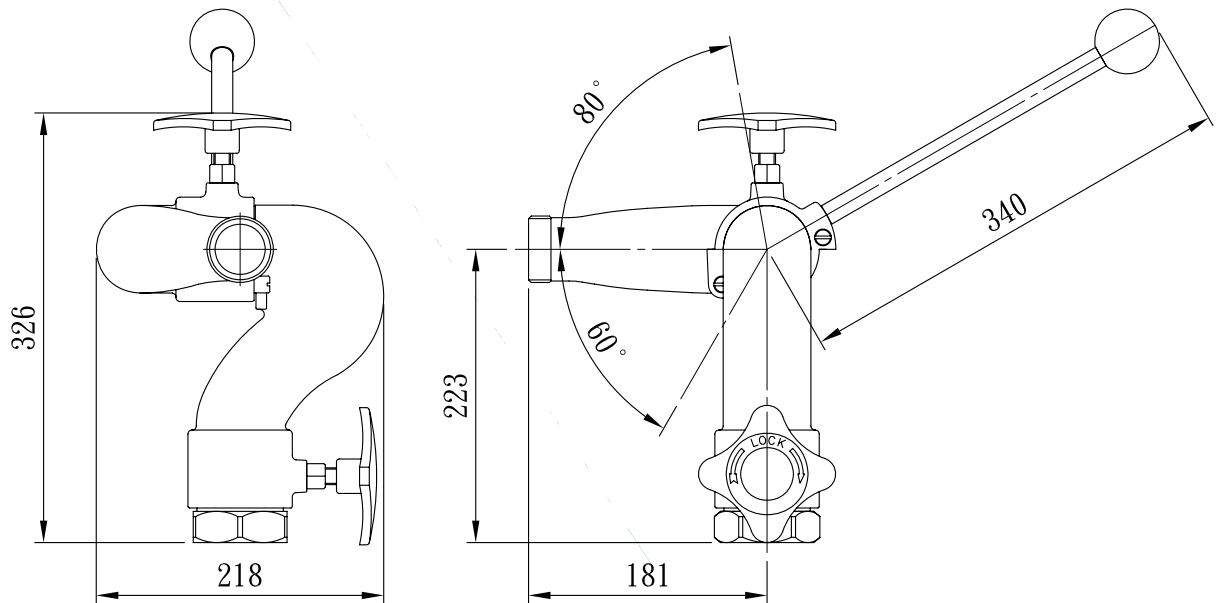

- Corrosion resistant cast brass construction ideal for marine, offshore, industrial and other corrosive environments
- Full 2" waterway for flow rate of up to 500 GPM (1900 LPM)
- Cast-in turning vanes for efficient flow
- Full 360° rotation
- Vertical travel of 140° from 80° above and 60° below horizontal
- Positive friction locks with brass knob for both horizontal and vertical travel to hold desired position
- Operating pressure of 200 psi (14 bar)
- Stainless steel lever for durability and easy control
- Rugged, lightweight and flow-efficient monitor with high reliability and minimal maintenance
- Compatible with Protek's diverse range of water and self-educing foam monitor nozzles

## Specification

Style 605				
Max. GPM (LPM)		500 (1900)		
Inlet	Size	2"	2-1/2"	3"
	Type	Female Thread	Flange	
Outlet		1-1/2"		
Control		Tiller Bar		
Material		Brass		
Finish		Red Powder Coating		
Travel	140° vertical			
	360° Rotation			
Weight		19 Lbs. (9 kg)		

