

To increase or decrease the tension and play of the adjusting handle, perform the following steps:  
 FIG. 5 Loosen the Adjusting Nuts with two 3/4 wrenches. Now tighten the top Adjusting Nut until the Handle completely disengages the Plunger from the Selector Plate. (If handle works properly go to Fig 7)

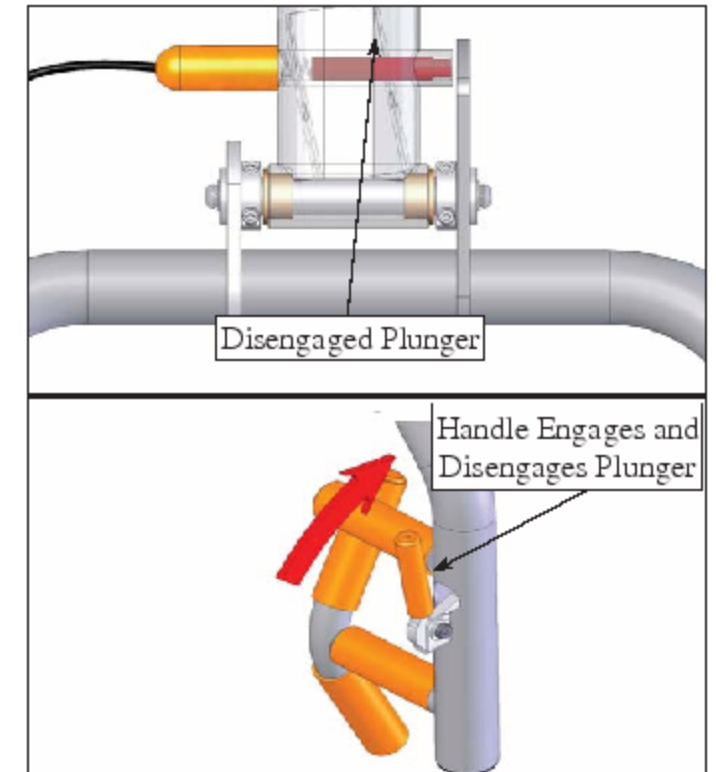

FIG. 7 Before using the machine, be sure that the Plunger fits easily into all seven (7) of the Adjustment Plate Holes and that the end of the Plunger does not make contact with the Adjustment Plate while changing from one position to the other. (if handle is loose or needs adjusting, please refer to Fig. 5 and 6.)

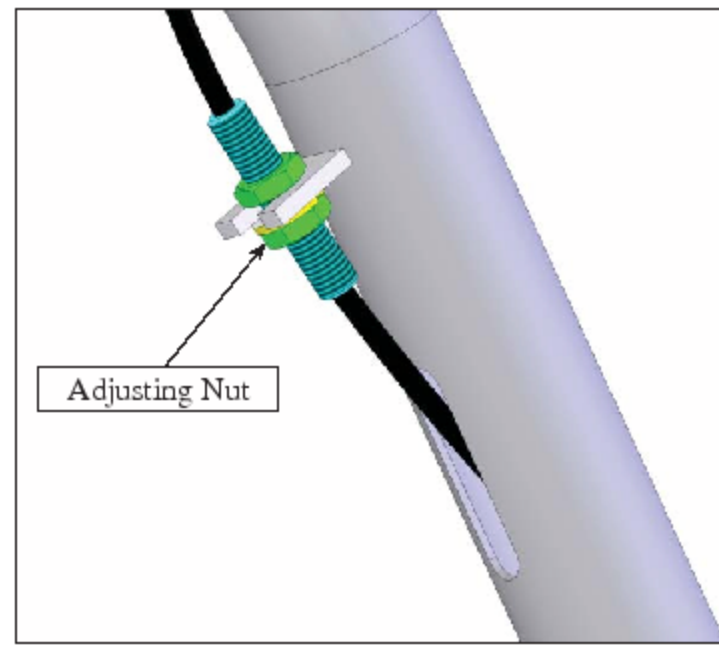

FIG. 6 Once you have the handle working properly, tighten the bottom Adjusting Nut.

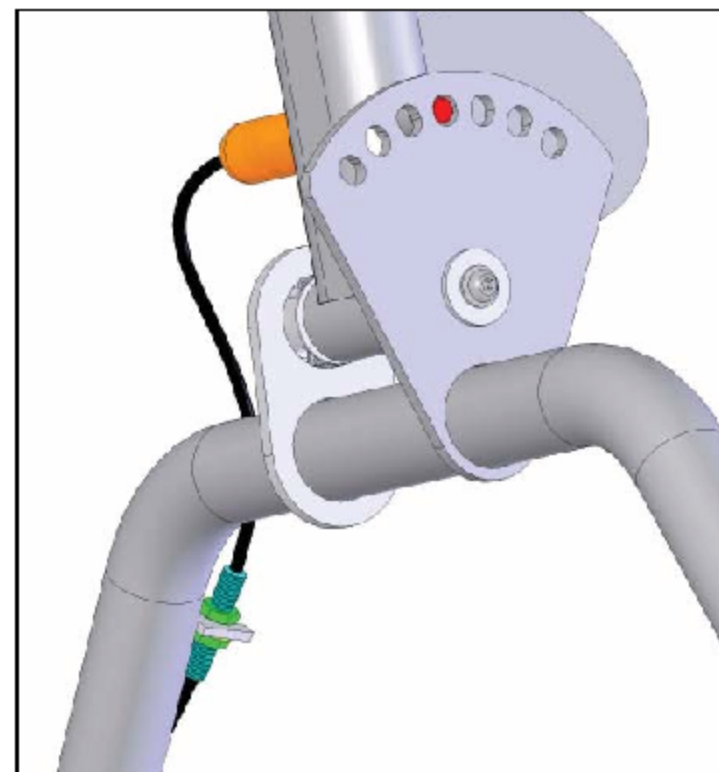
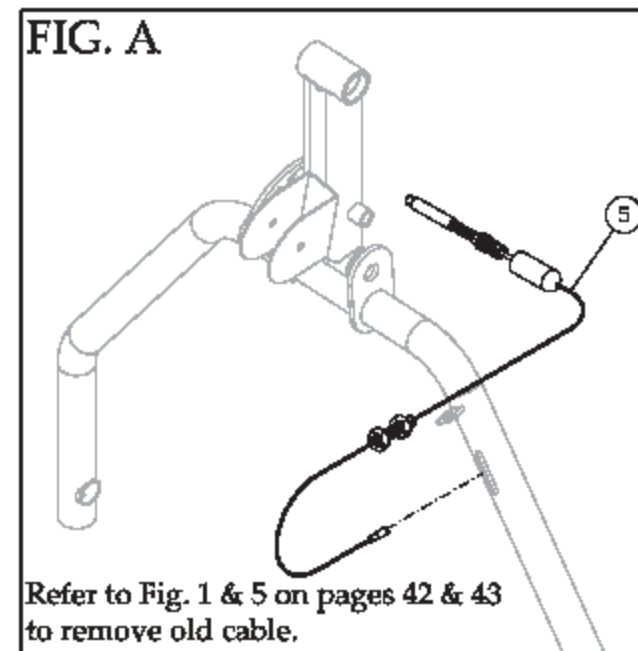
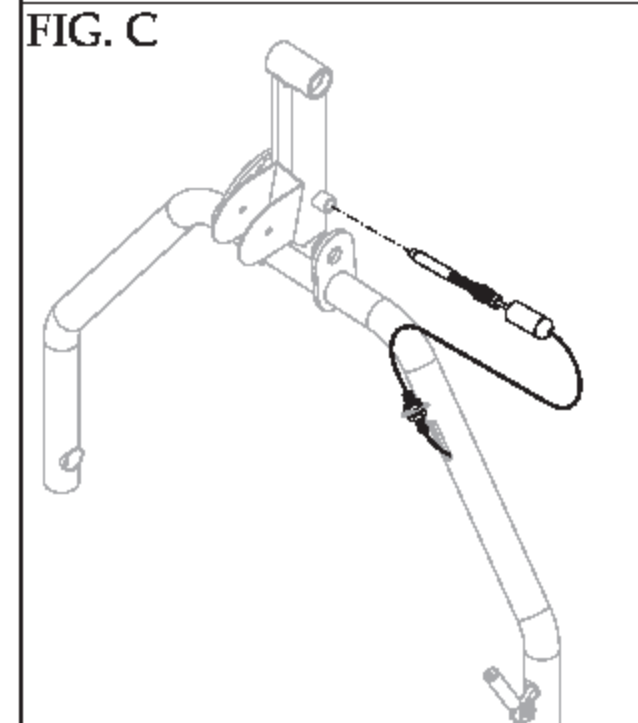

FIG. 8 This illustration depicts the ideal setting for the plunger, as shown flushed with the outside surface of the Adjustment Plate.



Refer to Fig. 1 & 5 on pages 42 & 43 to remove old cable.

1. Loosen **Jam Nut** and remove **Retaining Nut**.
2. Loosen and remove **Adjusting Nuts**.
3. Disassemble **Handle** as shown on next step (FIG B).
4. Insert new cable into slot and run down tube.



Refer to page 42 FIG. 2

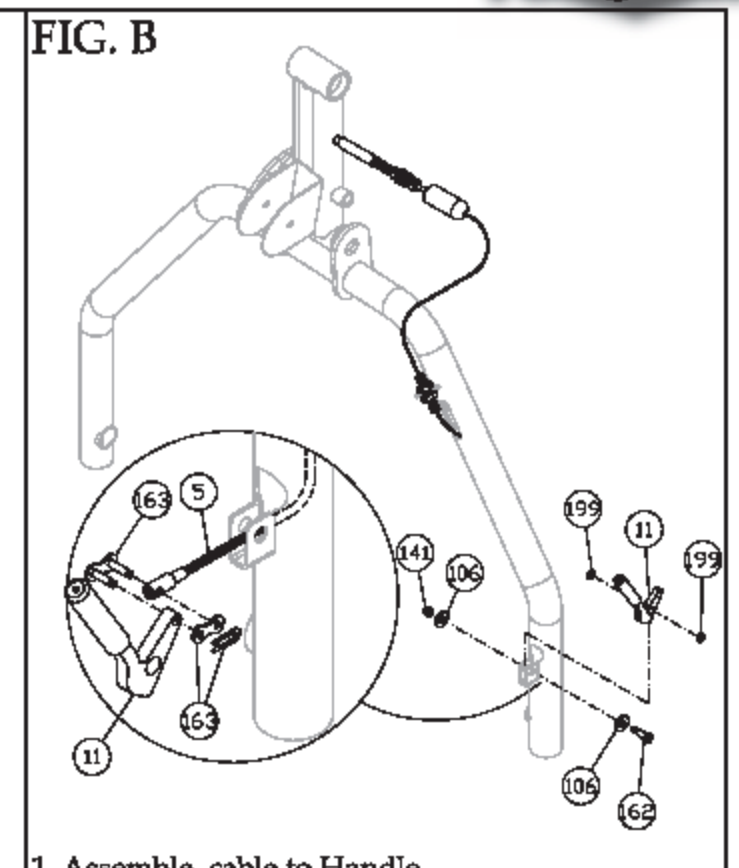

1. Assemble cable to Handle.
2. Assemble handle to Press Bar

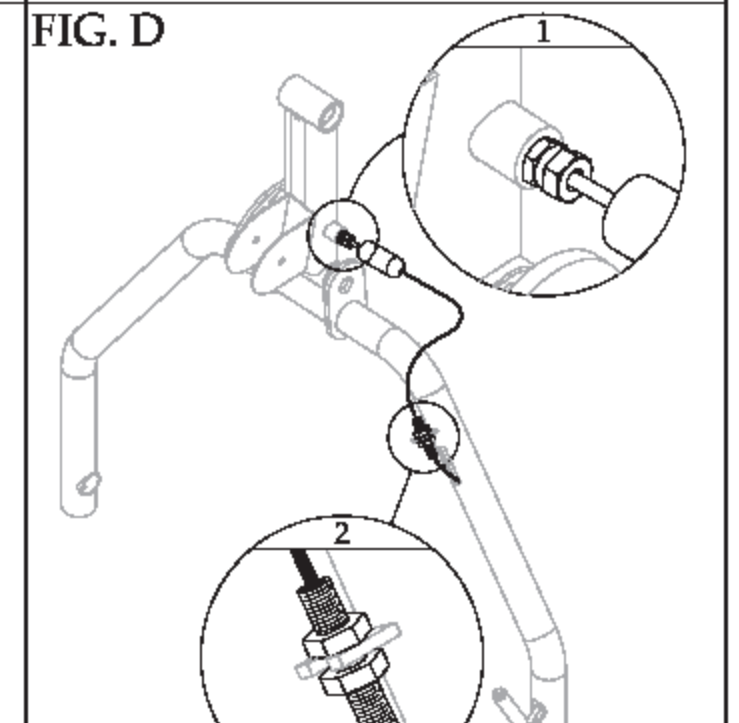

1. Refer to page 42 FIG. 3
2. Refer to page 43 FIG. 5 and 6

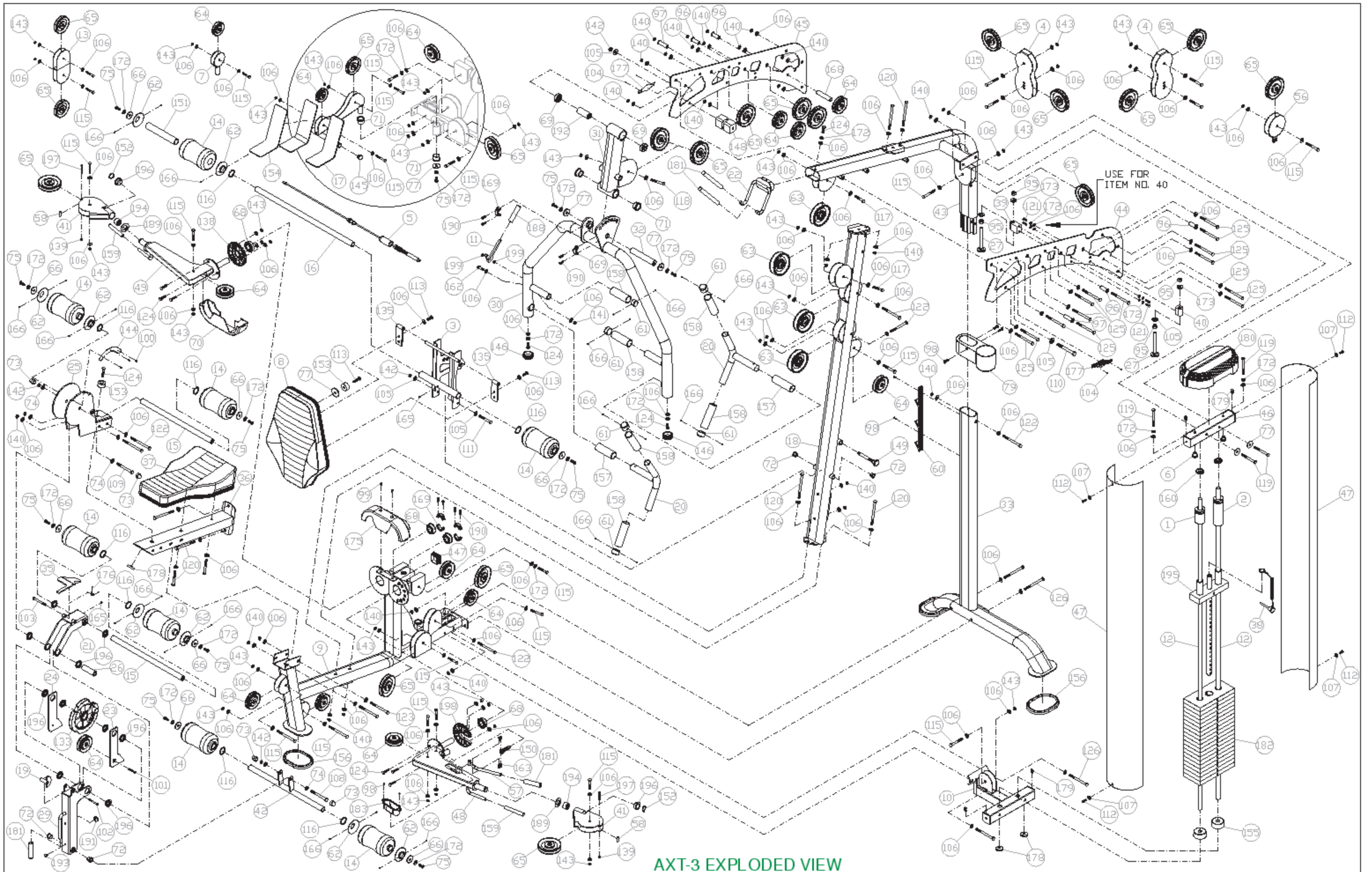

**AXT-3 EXPLODED VIEW**

AXT-3S\_AXT-3D AXT- User Defined Home Gym