

PROGRESSION
Fitness™

200

SERIAL NO: _____

DATE OF PURCHASE: _____

Write the serial number in the space above
for reference.

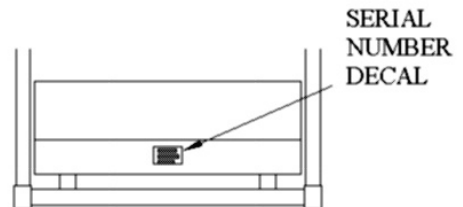

OWNER'S MANUAL

**ASSEMBLY • OPERATION • MAINTENANCE
WARRANTY • PART ORDERING**

▲ CAUTION: Exercise of a strenuous nature, as is customarily done on this equipment, should not be undertaken without first consulting a physician. No specific health claims are made or implied as they relate to the equipment.

IMPORTANT: Read all instructions carefully before using this product. Retain this owner's manual for future reference.

TABLE OF CONTENTS

Safety Precautions.....	2
Before you begin.....	4
Assembly.....	5
Operation and adjustment.....	10
Folding.....	16
Parts list.....	17
Overview Drawing.....	14
Trouble Shooting.....	22
Treadbelt Adjustment.....	23
Treadmill Lubrication	24
Cleaning and Maintenance.....	25
Training Guidelines	27
Exercise Routine.....	30
Warranty.....	32

IMPORTANT SAFETY INFORMATION
THIS UNIT IS INTENDED FOR HOUSEHOLD USE ONLY
READ ALL INSTRUCTIONS BEFORE USING THIS TREADMILL

- ▲ **CAUTION:** Before starting any exercise program, it is recommended that you consult your physician.
- ▲ **WARNING:** Connect this unit to a properly grounded outlet only.
- ▲ **DANGER:** To reduce the risk of electric shock, always unplug the treadmill from the electrical outlet immediately after using and before cleaning.

WARNING

To reduce the risk of burns, fire, electric shock, or injury to persons:

1. Use 120 volt a.c. household current on a dedicated circuit.

Grounding Instructions

This product must be grounded. If it should malfunction or breakdown, grounding provides a path of least resistance for electric current to reduce the risk of electric shock. This product is equipped with a cord having an equipment-grounding conductor and a grounding plug. The plug must be plugged into an appropriate outlet that is properly installed and grounded in accordance with all local codes and ordinances. See diagram below for grounding methods.

Figure 1.

Grounding methods

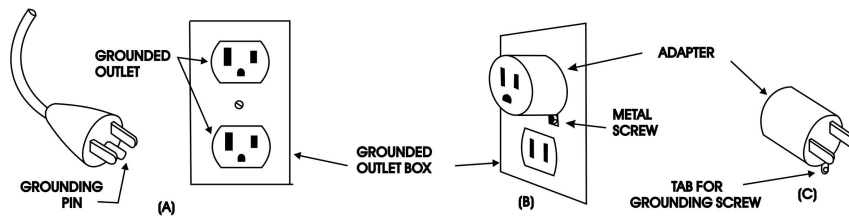

AA 200

2. It is the responsibility of the owner to ensure that all users of this treadmill are adequately informed of all warnings and precautions.
3. The use of an extension cord with this product is not recommended. If an extension cord is needed, use a short (less than 10 feet) heavy gauge (14 gauge or better) extension cord with a three prong (grounded) plug and receptacle.
4. Never leave the treadmill unattended when plugged in. Remove the safety key and unplug the unit from the outlet when not in use and before removing or replacing parts.
5. Never operate the treadmill if it has a damaged cord or plug, if it is not working properly, if it has been dropped, damaged, or exposed to water. Never move the treadmill belt while the power is turned off.
6. Do not pull the treadmill by the power supply cord or use cord as a handle. Keep cord away from heated surfaces and open flames.
7. Fitness equipment must always be installed and used on a flat surface. Do not use outdoors or near water. Do not place the unit on a loose rug or uneven surface. It is recommended to use an equipment mat to prevent the unit from moving while it is being used, which could possibly scratch or damage the surface of your floor. It is recommended to have a minimum of 3 metres safe clearance on all sides of the treadmill while in use.
8. Keep the treadmill indoors, away from moisture and dust. Do not put the treadmill in a garage, covered patio or near water.
9. Do not operate the treadmill where aerosol products are used or where oxygen is being administered.
10. Read, understand and test the emergency stop procedure before using the treadmill (see operation and adjustment on page 8)
11. Do not insert any objects into any openings.
12. Inspect and properly tighten all parts of the treadmill regularly.
13. Keep children and pets away from this equipment at all times while exercising.
14. Handicapped individuals should have medical approval and close supervision when using this treadmill.
15. Do not place hands or feet under the treadmill. Always keep hands and legs off of the treadmill when others are using it.

16. Never turn on treadmill while standing on treadbelt. Always hold the handrails while using the treadmill. Always return the treadmill to the slowest speed to provide for safe dismount and low speed restart.
17. To disconnect, turn all controls to the off position, then remove plug from outlet.
18. Do not attempt to raise, lower or move the treadmill until it is properly assembled. See assembly on page 5 and to fold and move the treadmill on page 11. Care must be taken when lifting or moving the equipment, so as not to injure your back. Always use proper lifting techniques. You must use any attachments that are not recommended by the manufacturer.
19. Use the treadmill only for its intended use as described in this manual. Do not use any attachments that are not recommended by the manufacturer.
20. User weight should not exceed 300 (135kg).
21. Never allow more than one person on the treadmill at once.
22. Warm up 5 to 10 minutes before each workout and cool down 5 to 10 minutes afterward. This allows your heart rate to gradually increase and decrease and will help prevent straining muscles.
23. Never hold your breath while exercising. Breathing should remain at a normal rate in conjunction with the level of exercise being performed.
24. Start your program slowly and very gradually increase your speed and distance.
25. Always wear suitable clothing and footwear while exercising. Do not wear loose fitting clothing that could become entangled with the moving parts of your treadmill. Do not walk or jog barefoot, in stocking feet or loose fitting shoes or slippers.
26. This treadmill is intended for in-home use only. Do not use the treadmill in any commercial, rental or institutional setting.

▲WARNING: Before beginning any exercise program consult your physician. This is especially important for individuals over the age of 35 or persons with pre-existing health problems. Read all instructions before using any fitness equipment. We assume no responsibility from personal injury or property damage sustained by or through the use of this product.

SAVE THESE INSTRUCTIONS

Before you begin.

Thank you for purchasing our product. Even though we go to great efforts to ensure the quality of each product we produce, occasional errors and /or omissions do occur. In any event should you find this product to have either a defective or a missing part please contact us for a replacement.

This product has been designed for home use only. Product liability and guarantee conditions will not be applicable to products being subjected to professional use or products being used in a gym center.

This exercise equipment was designed and built for optimum safety. However, certain precautions apply whenever you operate a piece of exercise equipment. **Be sure to read the entire manual before assembly and operation of this machine.**

Before reading further, please familiarize yourself with the parts that are labeled in the drawing below.

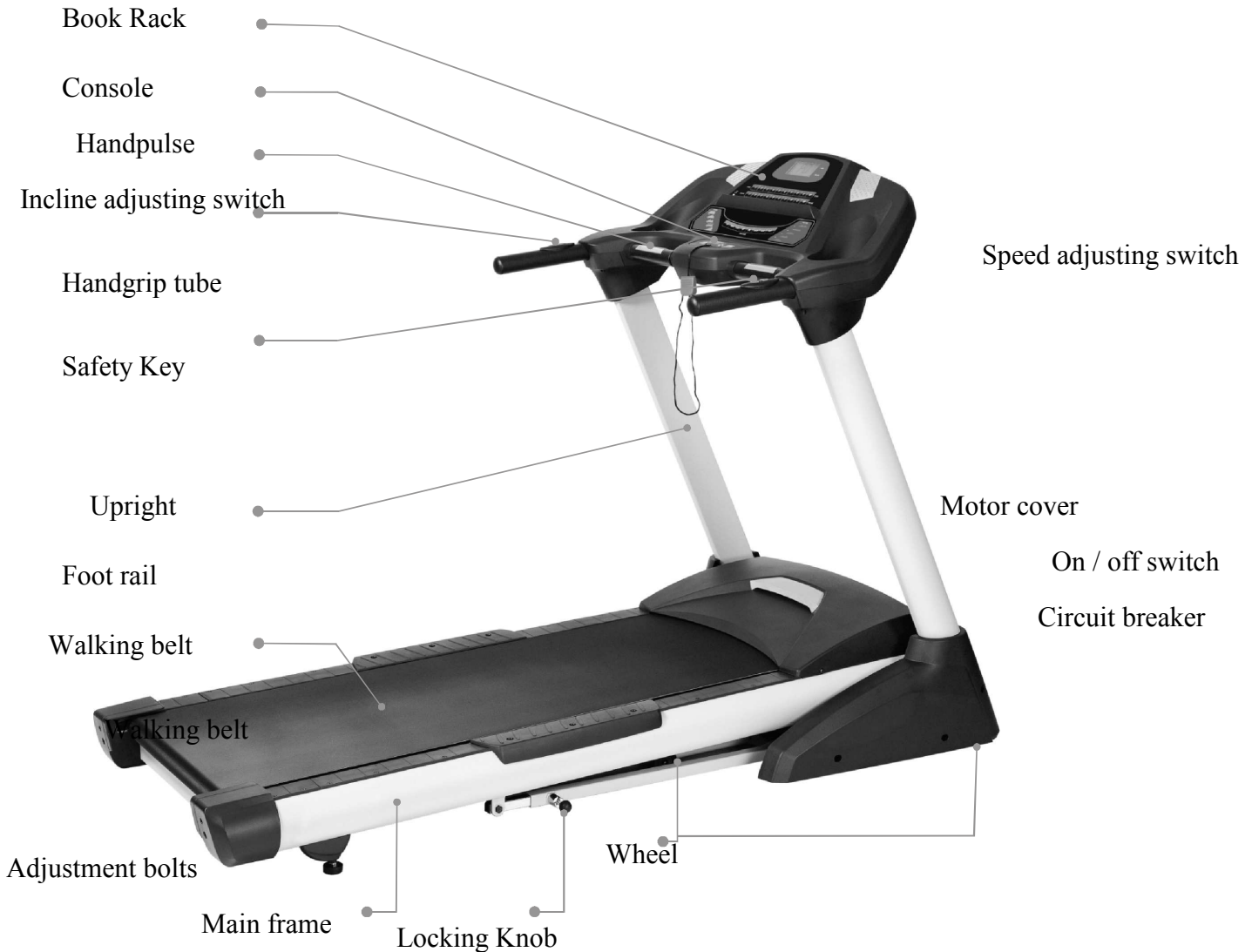

MAX. USER WEIGHT LIMIT 135 KGS (300 LBS)

HARDWARE CHECK LIST

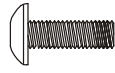

#96. M5 x 10 m/m
Phillips Head Screw (6pcs)

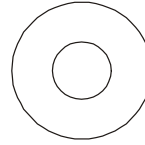

#95. ϕ 5/16"x19x1.5T Curved Washer
(8pcs)

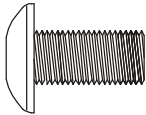

#94. 5/16" x15m/m
Button Head Socket Bolt (14pcs)

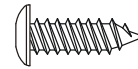

#90. 3.5x12 m/m
Self Tapping Screw (4pcs)

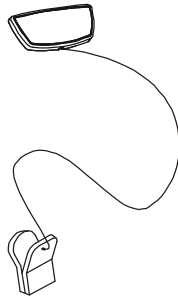

#102. Safety Key (1pc)

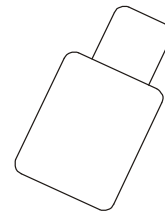

#93 Lubricant (1pc)

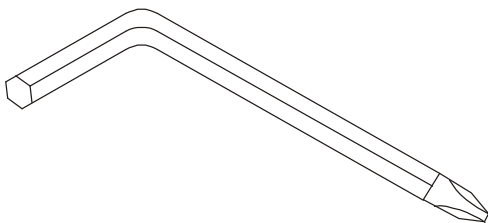

##97. Combination M5 Allen Wrench &
Phillips Head Screw Driver (1 pc)

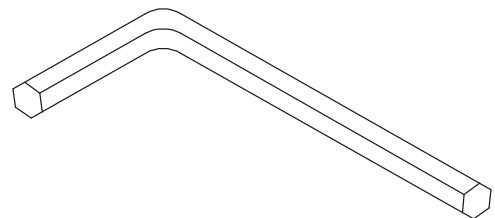

#98 M6 Allen Wrench (1pc)

ASSEMBLY INSTRUCTION

It will take two people to assemble your unit.

Set the treadmill in a cleared area and remove all packing material. Do not dispose of the material until your assembly is completed. Note: The underside of your treadmill's walking belt is coated with a lubricant. During shipping, a small amount of lubricant may be transferred to the top of the walking belt or the shipping carton. This does not affect the treadmill's performance. If you notice any lubricant on the top of the walking belt, simply wipe off the lubricant with a soft cloth and a mild, non abrasive cleaner.

For the sake of familiarizing yourself with the parts identified in the instructions, first study the overview drawing.

Assembly only requires the included wrenches.

Step 1.

Remove the treadmill from the carton and lay it on a smooth level surface.

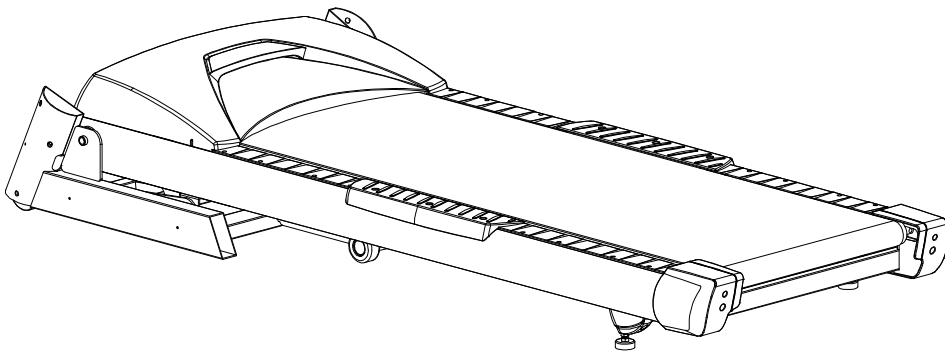

Step2.

Connect the Lower Computer Cable (38) to the Extension Computer Cable (37).

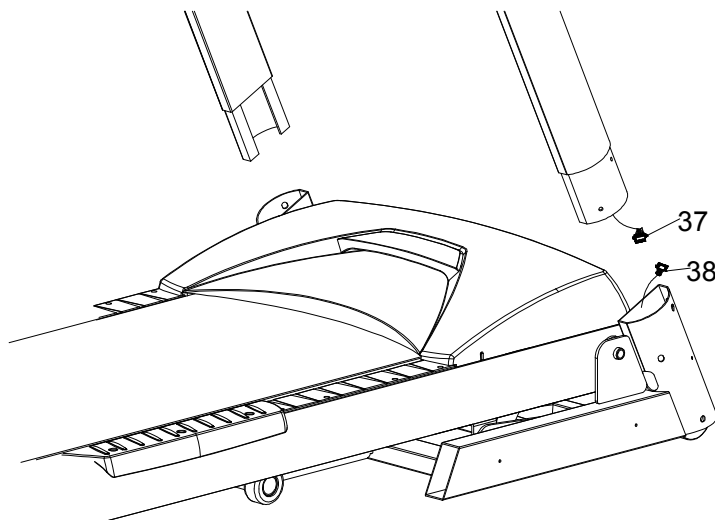

Step 3

Secure the right and left Upright (4,5) into the Frame Base with the 8pcs of 5/16"x15m/m Button Head Socket Bolts (94) and 4 pcs of 5/16" x 19 x 1.5T Curved Washers (95). Be careful not to pinch the computer cable when installing the Right Upright.

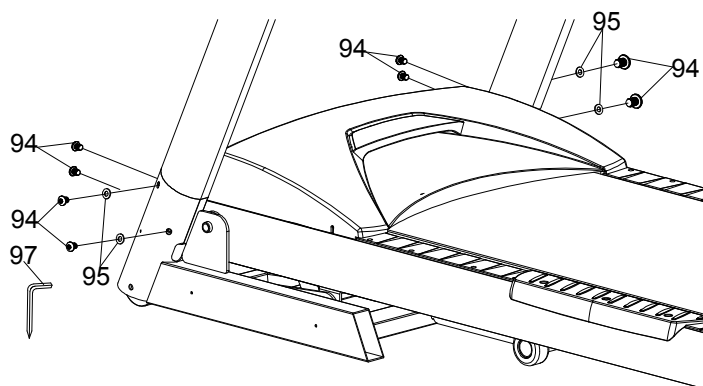

Step 4.

Install the Left Upright Cover (41) onto the Left Upright (4) and the Right Upright Cover (40) onto the Right Upright (5). Ensure that the covers are facing the correct direction and allow them to slide down and sit at the bottom of the uprights.

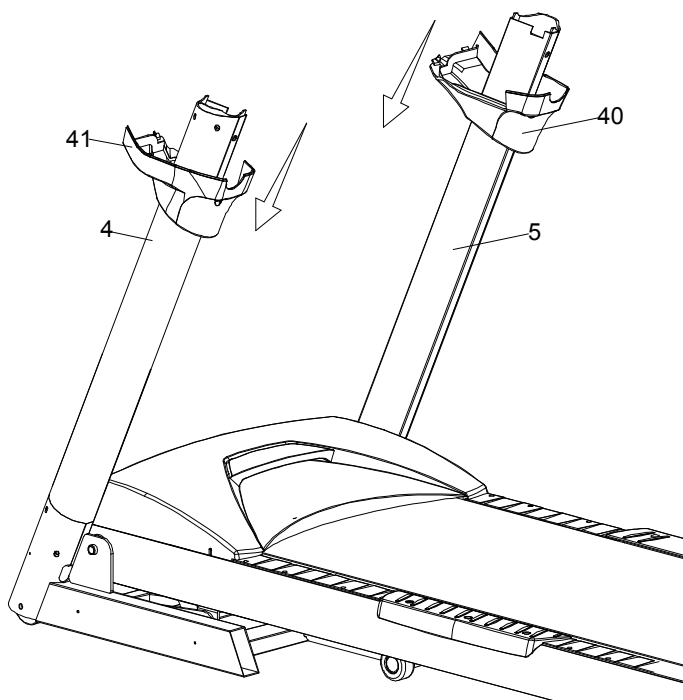

Step 5.

Connect the Extension Computer Cable (37) with the Upper Computer Cable (36).

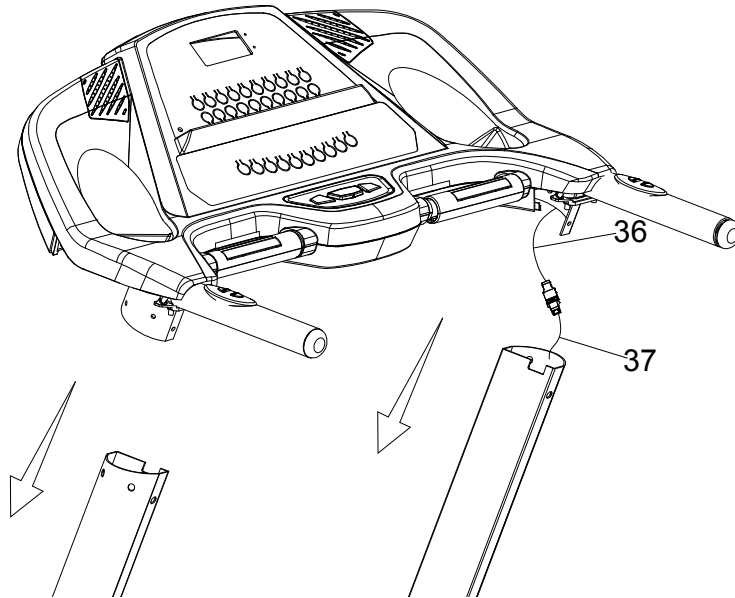

Step 6.

Secure the Console Assembly (39) into the Left & Right Uprights (4,5) with the 6pcs of 5/16" x 15m/m Button Head Socket Bolts (94) and 4 pcs of 5/16" x 19 x 1.5T Curved Washers (95).

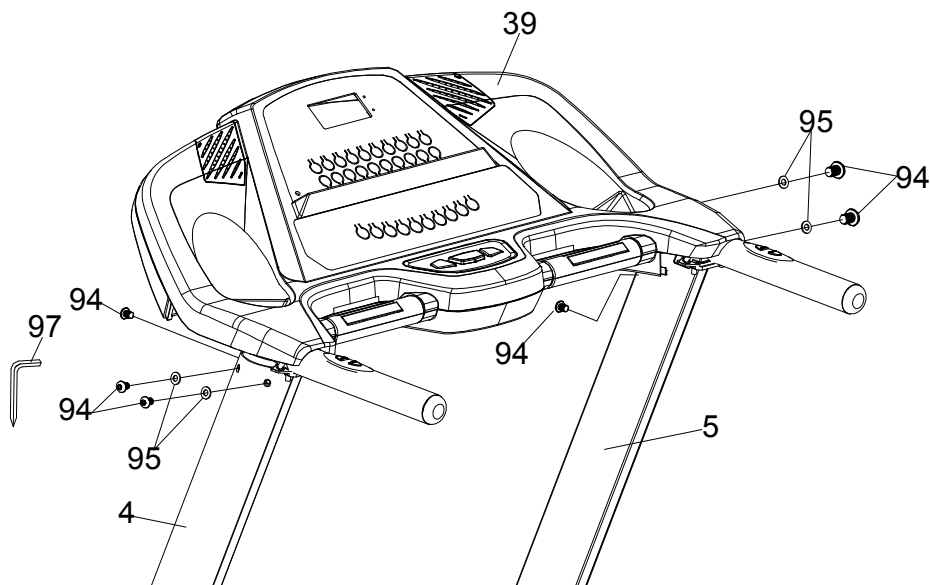

Step 7.

Secure the Left and Right Upright Covers (41, 40) to the Console Assembly (39) with the 4 pcs of 3.5x12m/m Self Tapping Screws (90).

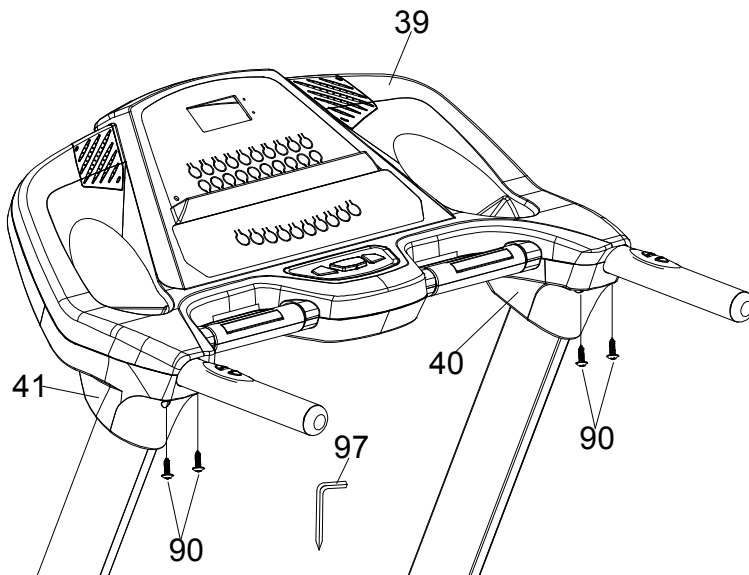

Step 8.

Install the Frame Base Caps (44,43) onto the Frame Base. Secure with 6pcs of M5x10m/m Phillips Head Screws (96).

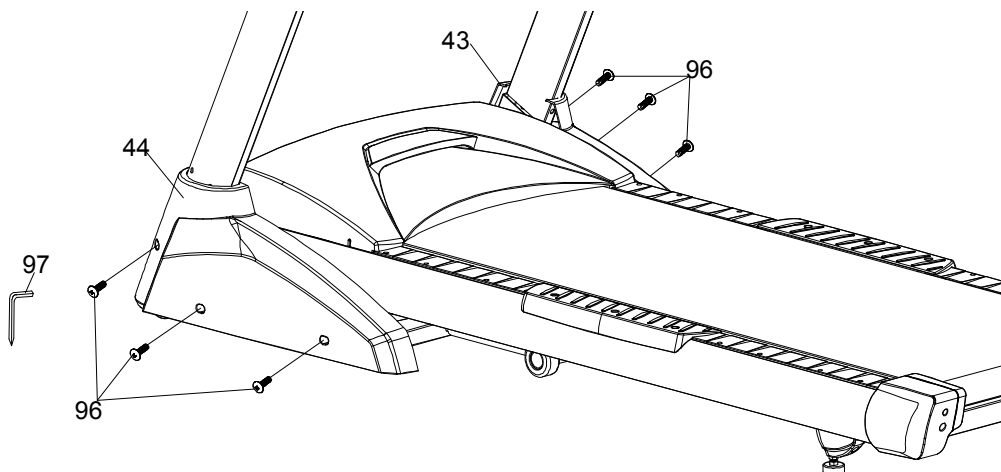

NOTE: Ensure that all nuts and bolts are tightened.

TREADMILL OPERATION

Your treadmill features a walking belt coated with a lubricant. **IMPORTANT:** Never apply silicone spray or other substances to the walking belt or walking board. Such substances will deteriorate the walking belt and cause excessive wear.

How to plug in the power cord.

GROUNDING INSTRUCTIONS.

This product must be grounded. No plug adapter should be used with this product.

▲ WARNING: Improper connection of the equipment grounding conductor can result in a risk of an electric shock. Check with a qualified electrician if you are in doubt as to whether the product is properly grounded. Do not modify the plug provided with the product, if it will not fit the outlet; have a proper outlet installed by a qualified electrician. The use of an extension cord with this product is not recommended. If an extension cord is needed, use a short (less than 10 feet) heavy gauge (14 gauge or better) extension cord with a three prong (grounded) plug and receptacle. **IMPORTANT:** If the power cord is damaged, it must be replaced with a manufacturer recommended power cord.

1. Plug the indicated end of the power cord into the socket of the treadmill. See drawing below
2. Plug the power cord into an appropriate outlet that is properly installed and grounded. See drawing below. Important: The treadmill is not compatible with GFCI-equipped outlets.

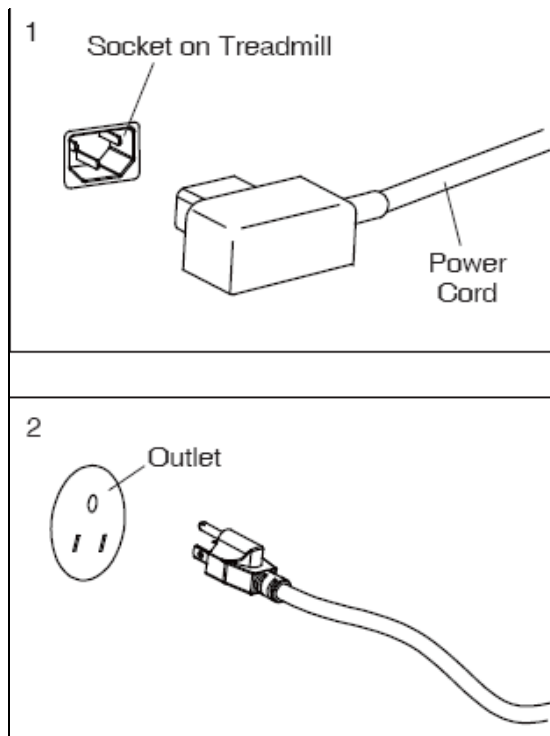

Note: Your power cord and outlet may appear different.

MONITOR INSTRUCTIONS

▲ **CAUTION:** Before operating the console, read the following precautions:

- Do not stand on the walking belt when turning on the treadmill
- Always wear the safety key
- Adjust the speed in small increments to avoid sudden jumps in speed
- To reduce the possibility of electric shock, keep the console dry. Avoid spilling liquids on the console and place only sealed water bottles in the water bottle holders.

TO OPERATE TREADMILL

▲ **CAUTION:** To avoid injury, hold onto the handrails while mounting and dismounting the treadmill. Hold onto the handrails and place feet on siderails before starting. Step onto the walking belt only a slowest speed.

Before operating the console make sure that the power cord is properly plugged in and the on / off button is on.

1. Hold onto handrail and place feet on siderails before starting treadmill. (Do not stand on treadbelt).
2. Attach the magnet end of the safety key onto the monitor and attach the clip end of the safety key to your clothing (ie: waistband). If you should slip or fall while exercising the safety key will pull out of the console, shutting off the treadmill.
Choose which program you want to select, manual (P0) or pre-set (p1-p5).



Initial Display:

When the power is turned on, the main display will light up showing all characters. The console will be performing an internal test to make sure the console is operational. The display will then scroll through three numbers, the first showing the current software version, second is how many hours the treadmill has been in use and third is how many virtual miles the treadmill has gone. The treadmill will then enter idle mode and show P0 on the display, which is the starting point for operation.

WINDOW DISPLAY DATA:

SCAN:	When lit, will scan through all the display information; each one for 5 seconds.
SPEED:	Displays the current belt speed from starting at 1.0Mph to 10.0Mph.
TIME:	Accumulates total workout time from 00:00 to 99:59.
DISTANCE:	Accumulates total workout distance from 0.00 to 99.99 miles.
CALORIES:	Accumulates the user's calorie consumption during exercise. Max. Value is 9999 calories.
PULSE:	Displays your current heart rate in beats per minute from 40 to 240.
♥ Icon:	The heart icon blinks when a pulse is detected.
INCLINE LED:	When lit, the display will be showing the elevation position from 0 to 10.
LUBE LED:	Reminds the user to apply silicon lubricant between the belt and deck. To turn off the light press and hold the SELECT button for 5 seconds.

FUNCTION BUTTON:

START:	Press "START" button to start training.
STOP:	Press "STOP" button to stop training and press for 3 seconds to reset.
FAST:	Press "FAST" button to increase your speed.
SLOW:	Press "SLOW" button to decrease your speed.
UP:	Press "UP" button to increase elevation position.
DOWN:	Press "DOWN" button to decrease elevation position.
ENTER:	Press "ENTER" button to select different setting parameters in STOP mode.
SELECT:	Press "SELECT" button to scroll through the display workout information.

PROGRAM UP/DOWN: Press PROGRAMUP/DOWN buttons to scroll through workout programs.

RAPID SPEED KEYS: 10 preset speed buttons to jump to a desired speed quickly. You can also press the any of the 10 buttons to start treadmill from the start-up screen. The treadmill will automatically start and slowly increase speed to the preset number.

RAPID INCLINE KEYS: 10 preset incline buttons to jump to a desired incline setting quickly.

Quick-Start Operation:

- STEP 1:** Attach the Safety key to wake display up (if not already on). The main window will show the initial display: P0.
- STEP 2:** Press the START button to begin belt movement after a three second count down. Use the FAST/SLOW keys to adjust the desired speed (on console) at any time during training. Using the UP/DOWN keys to adjust the Incline at any time during training. To set the time to count down, see STEP 7.
- STEP 3:** Press the SELECT button to scroll through your workout data. The initial screen will be showing the SPEED. Pressing the SELECT button will show the TIME then DISTANCE, CALORIES, PULSE, INCLINE and SCAN. In scan mode each data will be displayed for 5 seconds.
- STEP 4:** To get a pulse reading, simply grasp both stainless steel pick-ups. Make sure the display is set to show Pulse, or Scan. When the ♥ Icon is flashing that means the console is receiving a pulse. It may take a few seconds for the display to reach the actual number.
- STEP 5:** While training, you can press STOP button to stop your workout or pull safety key away from its position to shut down the computer. If you want to resume your workout, you can press START button and all previous data will resume counting.
- STEP 6:** At the end of a program you can press FAST/SLOW to display the accumulated data for speed, time, distance and calories that are memorized during training.
- STEP 7:** To set a TARGET: Before training, press the ENTER button to be able to program the time clock to count down. Use the up and down keys to set the time then press Start or Enter to program the Distance or Calories. If you set multiple parameters, the first one to reach zero ends the program.

To Select a Program:

- Step 1:** Press the ^ or v button to choose P1 ~ P5, each program has a preset speed value.
- Step 2:** Press the ENTER button to set the count down time from 10:00 to 99:00; the preset value is 20:00. You can adjust the value by pressing FAST/SLOW or press START button to start training immediately.
- Step 3:** Press STOP button to stop your workout or pull safety key away from its position to shut down the computer.

Pulse Feature:

The Pulse (Heart Rate) window will display your current heart rate in beats per minute during the workout. You must use both stainless steel sensors on the front cross bar to display your pulse. Pulse value displays anytime the upper display is receiving a Pulse signal.

Optional Feature:

*There is an **Audio Input Jack** on the front of the console and built-in speakers. You may plug any low-level audio source signal into this port. Audio sources include MP3, Ipod, portable radio, CD player or even a TV or computer audio signal.*

ERROR MESSAGE:

1. LS: Treadmill doesn't receive the speed signal for 8 seconds.
2. E1: Memory of console malfunction or CPU accessing problem.
3. Err: Incline position error.

SPEED PROFILE

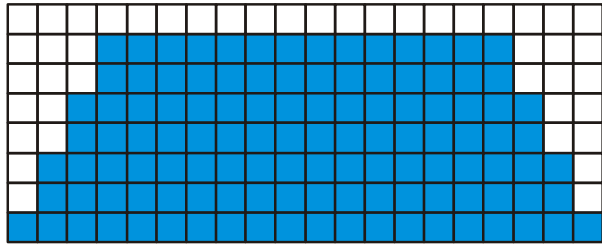

P.1

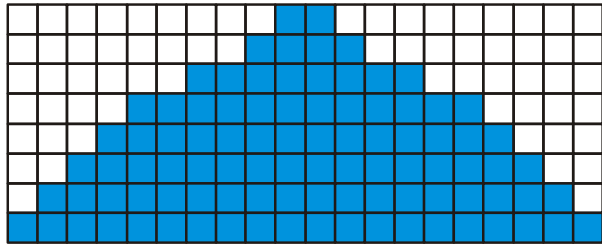

P.2

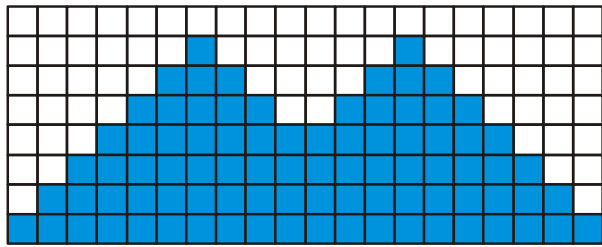

P.3

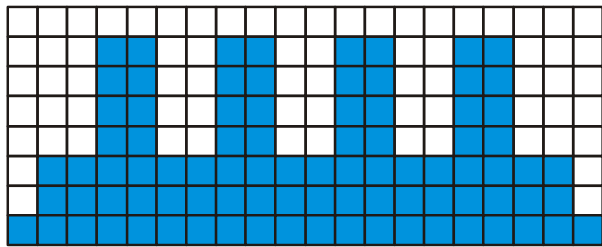

P.4

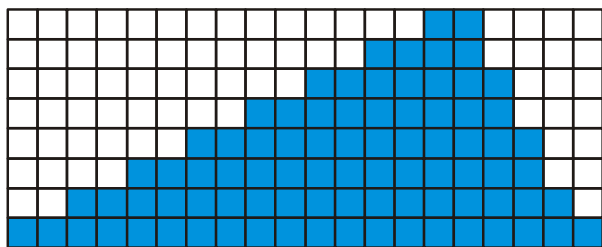

P.5

INCLINE PROFILE

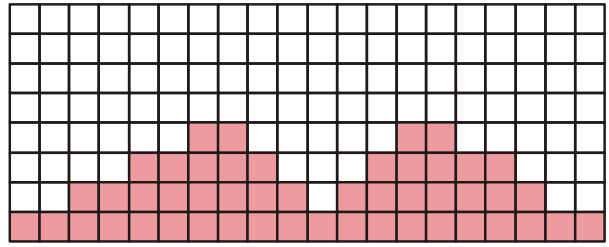

P.1

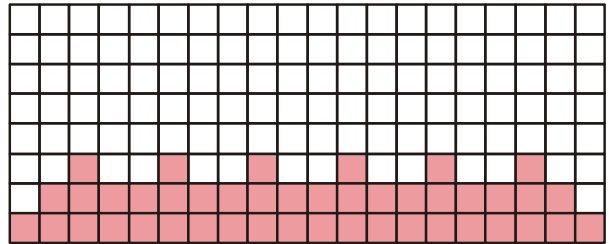

P.2

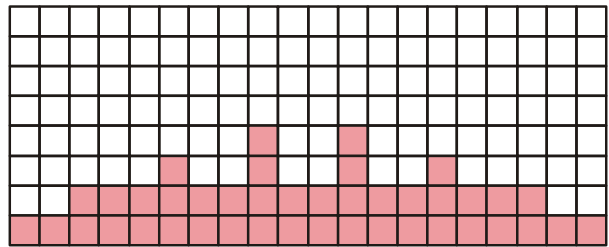

P.3

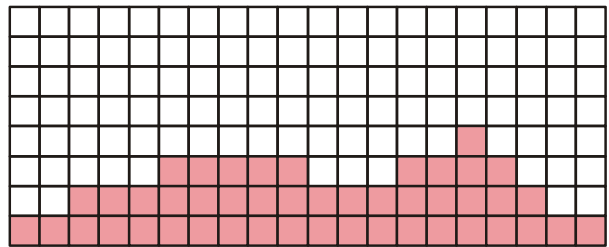

P.4

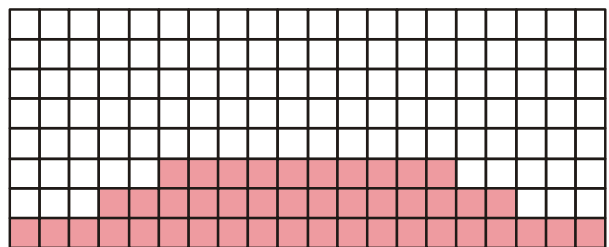

P.5

FOLDING AND MOVING YOUR TREADMILL

Before folding the treadmill, ensure that the treadmill is at its lowest incline position. Turn the power switch off, located on the front of the motor cover and unplug the power cord.

CAUTION: You must be able to safely lift 20 kg (45lbs) in order to raise and lower the treadmill. To decrease the possibility of injury, bend your legs and keep your back straight while you are raising or lowering your treadmill.

To protect the floor or carpet from damage, place a mat under the treadmill. Keep the treadmill out of direct sunlight. Do not leave the treadmill in the storage position in temperatures above 85 degrees Fahrenheit.

Unfolding

Hold the treadmill running deck with left hand. Pull the locking knob with your right hand and slowly lower the treadmill running deck. The deck will lower unassisted when it reaches about waist high.

Folding

Lift the treadmill running deck with your left hand. Pull the locking knob with your right hand and slowly raise the treadmill running deck until the treadmill is locked by the locking knob.

Moving

Before moving the treadmill, fold the treadmill to the stored position as described above. Hold the handgrip tubes and carefully move the treadmill to your desired location.

To reduce the risk of injury, use extreme caution while moving the treadmill, do not attempt to move the treadmill over an uneven surface.

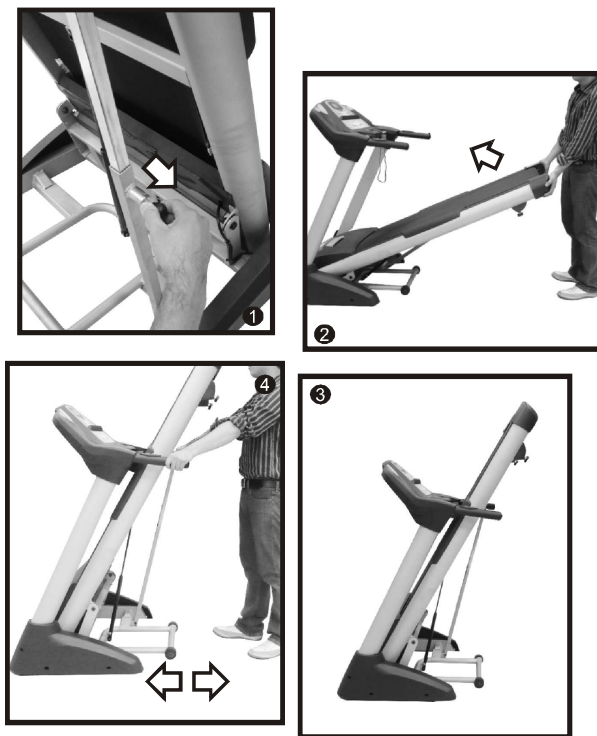

KEY NO.	PART NO.	DESCRIPTION	O'TY
1	020001	Main Frame	1
2	020002	Frame Base	1
3	020003	Incline Bracket	1
4	020004	Left Handrail	1
5	020005	Right Handrail	1
6	020006	Console Support	1
7	020007	Outer Slide	1
8	020008	Inner Slide	1
9	020009	Locking Knob Axle	1
10	020010	Bottom Motor Plate	1
11	020011	Belt Guide	2
12	020012	Running Deck	1
13	020013	Running Belt	1
14	020014	Drive Belt	1
15	020015	Front Roller W/Pulley	1
16	020016	Rear Roller	1
17	020017	Wheel Sleeve	2
18	020018	Magnet	2
19	020019	Cylinder	1
20	020020	Handgrip Foam	2
21	020021	Wire Tie Mount	5
22	020022	Motor	1
23	020023	Incline Motor	1
24	020024	Controller	1
25	020025	Speed Adjustment Switch W/Cable	1
26	020026	Incline Adjustment Switch W/Cable	1
27	020027	Handpulse W/Cable Assembly	2
27~1	020027-1	Handpulse Wire, Coiled	1
27~3	020027-3	Handpulse Assembly Top	2
27~4	020027-4	Handpulse Assembly Bottom	2
28	020028	Breaker	1
29	020029	Power Socket	1
30	020030	On/Off Switch	1
31	020031	Sensor W/Cable	1
32	020032	Power Cord	1
33	020033	200m/m x 764 x 764_Connecting Wires (White)	1
34	020034	200m/m x 764 x 764_Connecting Wires (Black)	1
35	020035	100m/m x 764 x 764_Connecting Wires (Black)	1
36	020036	Computer Cable (Upper)	1
37	020037	Computer Cable (Middle)	1
38	020038	Computer Cable (Lower)	1
39	020039	Console Assembly	1
39~1	020039-1	Top Console Cover	1
39~2	020039-2	Bottom Console Cover	1
39~3	020039-3	Inner Console Cover	1
39~4	020039-4	Console Speaker Cover (R)	1
39~5	020039-5	Console Speaker Cover (L)	1
39~8	020039-8	Speaker Grill Anchor	6

KEY NO.	PART NO.	DESCRIPTION	O'TY
39-13	020039-13	Amplifier	1
39-14	020039-14	Power Cord Of Amplifier	1
39-15	020039-15	300mm_Speaker	1
39-16	020039-16	750mm_Speaker	1
39-17	020039-17	Sound Board	1
39-18	020039-18	Sound Board W/Cable	1
39-19	020039-19	Safety Switch Module W/Cable	1
39-21	020039-21	3×10mm_Self Tapping Screw	14
40	020040	Right Handrail Cover	1
41	020041	Left Handrail Cover	1
42	020042	φ 38 _Button Head End Cap	2
43	020043	Frame Base Cap (R)	1
44	020044	Frame Base Cap (L)	1
45	020045	Front Transportation Wheel	2
46	020046	Rear Transportation Wheel	2
47	020047	Motor Cover Anchor	2
48	020048	Top Motor Cover	1
49	020049	Top Motor Cover Plate	1
50	020050	Front Motor Cover	1
51	020051	Foot Rail (L)	1
52	020052	Foot Rail (R)	1
53	020053	Front Foot Rail	4
54	020054	Rear Foot Rail	2
55	020055	Rear Adjustment Base (L)	1
56	020056	Rear Adjustment Base (R)	1
57	020057	Foot Pad Cap	2
58	020058	Cushion	6
59	020059	Foot Pad	2
60	020060	Sensor Rack	1
61	020061	φ 10 x 24 x 3T _Nylon Washer (A)	3
62	020062	φ 50 x 13 x 3T _Nylon Washer (B)	4
63	020063	1/2" x 1-1/4" _Carriage Bolt	2
64	020064	1/2" x 1" _Hex Head Bolt	2
65	020065	3/8" x 4" _Hex Head Bolt	1
66	020066	3/8" x92m/m _Hex Head Bolt	1
67	020067	3/8" x 3/4" _Hex Head Bolt	4
68	020068	3/8" x 1-1/2" _Hex Head Bolt	1
69	020069	3/8" x 45m/m _Hex Head Bolt	1
70	020070	3/8" x 2-1/2" _Thumb Head Socket Bolt	2
71	020071	5/16" x 1" _Button Head Socket Bolt	4
72	020072	M8 x 60m/m _Hex Head Bolt	1
73	020073	M8 x 65m/m _Socket Head Cap Bolt	2
74	020074	M8 x 25m/m _Flat Head Countersink Screw	8
75	020075	1/2" x 8T _Nyloc Nut	4
76	020076	3/8" x 7T _Nyloc Nut	6
77	020077	5/16" x 6T _Nyloc Nut	2
78	020078	M8 x 8T _Nyloc Nut	1
79	020079	3/8" x 7T _Nut	3
80	020080	35 x 5/16" x 1.5T _Flat Washer	2
81	020081	φ 25 x 10 x 2.0T _Flat Washer	4

KEY NO.	PART NO.	DESCRIPTION	O'TY
82	020082	ϕ 19 x 10 x 1.5T_Flat Washer	6
83	020083	3/8"×2.0T_Split Washer	4
84	020084	ϕ 5× ϕ 15×1.0T_Flat Washer	4
85	020085	M5_Raised Washer	3
86	020086	4x12m/m_Self Tapping Screw	4
87	020087	5x16m/m_Tapping Screw	32
88	020088	5x19m/m_Tapping Screw	7
89	020089	5x16m/m_Tapping Screw	8
90	020090	3.5x12m/m_Self Tapping Screw	13
91	020091	4x38m/m_Self Tapping Screw	2
92	020092	3.5x16m/m_Tapping Screw	5
93	020093	Lubricant	1
94	020094	5/16" x 15m/m_Button Head Socket Bolt	14
95	020095	ϕ 5/16" x 19 x 1.5T_Curved Washer	8
96	020096	M5×10mm_Phillips Head Screw	6
97	020097	Combination M5 Allen Wrench & Phillips Head Screw Driver	1
98	020098	M6_Combination M6 Allen Wrench & Phillips Head Screw Driver	1
99	020099	3/8"×2" _Hex Head Bolt	1
100	0200100	3×10mm_Tapping Screw	4
101	0200101	5×19mm_Tapping Screw	20
102	0200102	Trapezoidal Safety Key	1
106	0200106	21.4×21.4_Square End Cap	1
107	0200107	25.4×25.4_Square End Cap	1
108	0200108	Top Console Cover Anchor	2
109	0200109	3×10mm_Self Tapping Screw	2
110	0200110	3.5×12mm_Self Tapping Screw	12
111	0200111	ϕ 13× ϕ 26×2.0T_Flat Washer	4
112	0200112	Audio cable	1

EXPLODED DIAGRAM

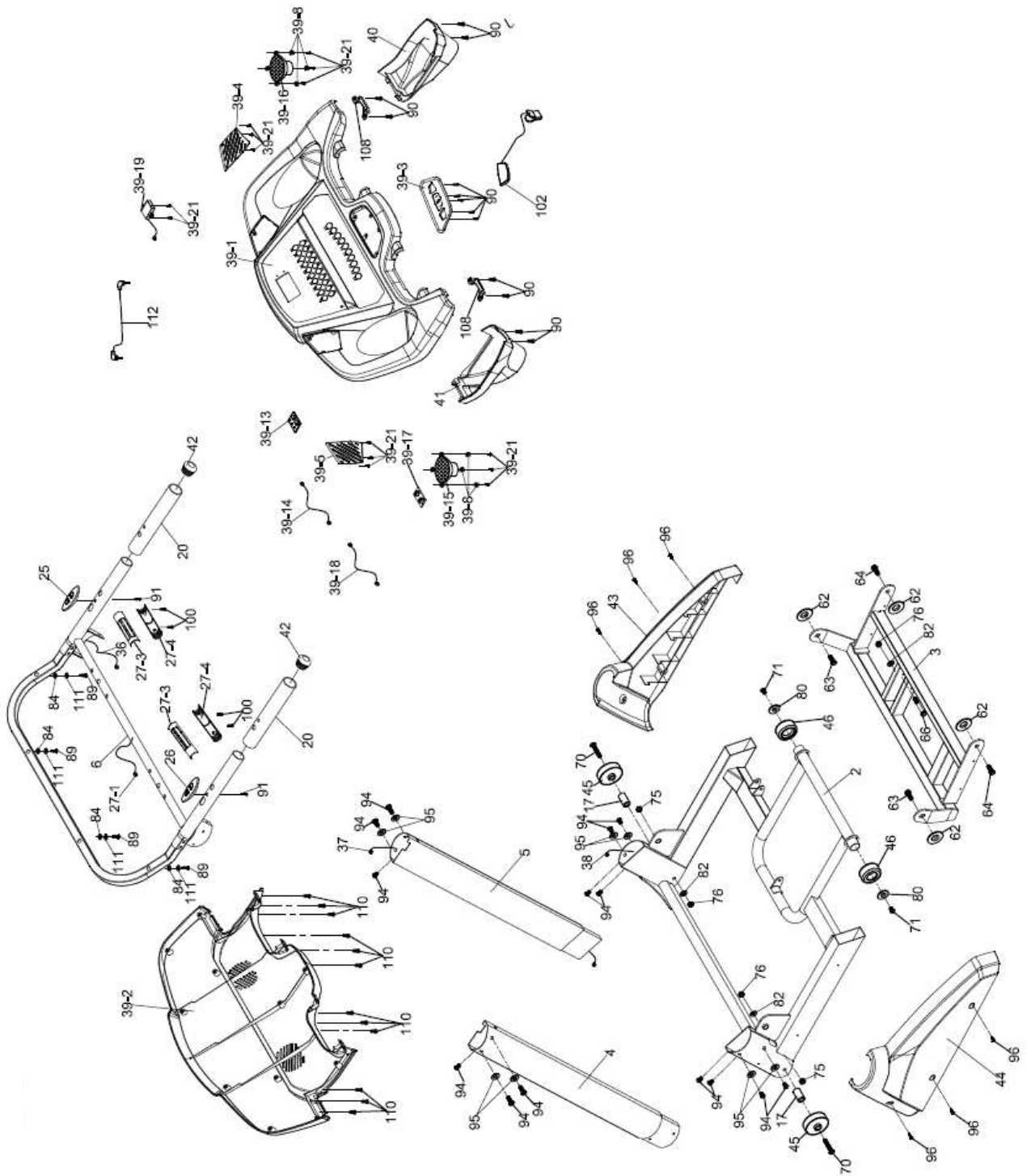

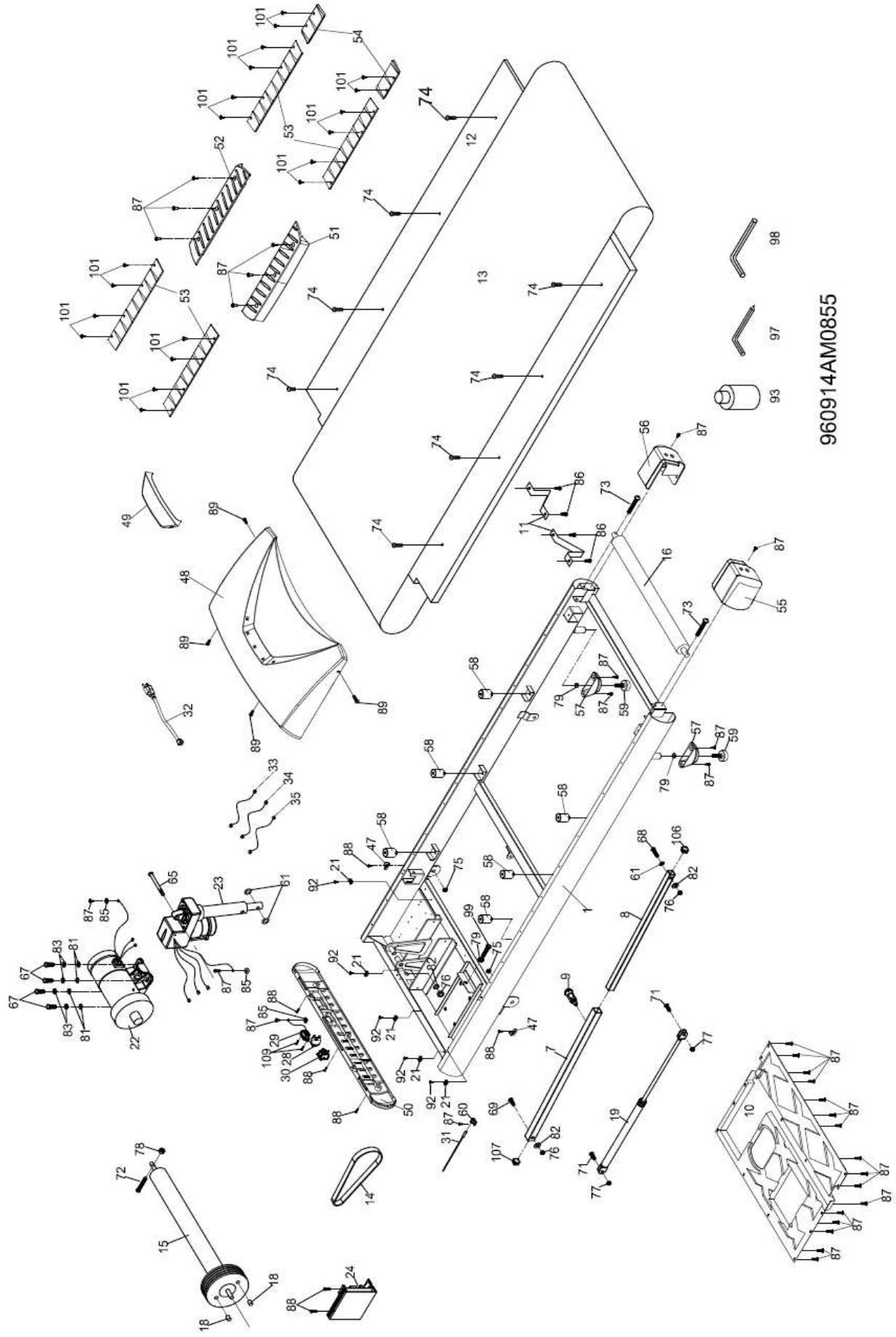

960914AM0855

TROUBLE SHOOTING

Problem	Cause	Correction
Treadmill will not start	Treadmill not plugged in	Plug into three prong (grounded) outlet
	On / off switch not on	Push the on/off button to on
	House circuit breaker tripped	Reset or replace
	Treadmill reset switch tripped	Reset treadmill reset switch see reset switch resetting (page 20)
	Treadmill motor controller fuse blown	Replace controller
	Unit plugged into insufficient extension cord	Plug directly into wall outlet
Treadmill stop or shuts off by itself	House circuit breaker tripped	Reset or replace
	Treadmill reset switch tripped	Reset treadmill reset switch (page 20)
	Treadmill motor controller fuse blown	Replace controller
Treadbelt does not run in center	Treadbelt tension not even across treadbelt	See treadbelt adjustment (page 17)
Treadbelt slips	Treadbelt tension too loose	See treadbelt adjustment (page 17)
Treadbelt hesitates while being stepped on	Insufficient lubricant on treadbelt	See treadbelt lubrication (page 18)
Black particles collecting under treadmill	Drive belt is breaking in	Vacuum under treadmill periodically
No display on monitor	On / off switch not on	Push on / off button to on
Monitor does not display speed or distance	Reed switch not aligned properly	see speed sensor adjustment (page 20)
	Magnet damaged or missing from front roller pulley	Replace magnet
	Monitor not working properly	Replace monitor
No pulse displayed on monitor	Hands not on hand pulse	Place two hands on hand pulse
	Hands on hand pulse	Replace hand pulse

NOTE: It is not necessary to return treadmill for a monitor repair. The monitor or console is removable from the treadmill for repair or replacement - see parts section

TREADBELT ADJUSTMENT

The treadmill has been factory pre-adjusted, however if during the operation:

Treadbelt slips during use if the treadbelt is too loose:

- a) Tighten both rear roller adjusting bolts 1/4 turn clockwise using allen wrench.

Treadbelt shifts too far to the right

- a) Set the treadmill speed to 3.5 M.P.H.
- b) Tighten the right adjusting bolt a 1/4 turn clockwise using allen wrench.
- c) Wait 15 seconds: if no change; turn the left adjusting bolt a 1/4 turn counter-clockwise using allen wrench.
- e) Repeat steps b and c until belt is centered

Treadbelt shifts too far to the left

- a) Set the treadmill speed to 3.5 M.P.H.
- b) Tighten the left adjusting bolt a 1/4 turn clockwise using allen wrench.
- c) Wait 15 seconds: if no change; turn the right adjusting bolt a 1/4 turn counter-clockwise using allen wrench.
- e) Repeat steps b and c until belt is centered

IMPORTANT

DO NOT OVERTIGHTEN TREADBELT

If treadbelt is over-tightened, edges of treadbelt will begin to curl

CAUTION!! DO NOT ALLOW ANYONE TO WALK ON TREADBELT WHILE YOU ARE ADJUSTING.

If Treadbelt slips during use.

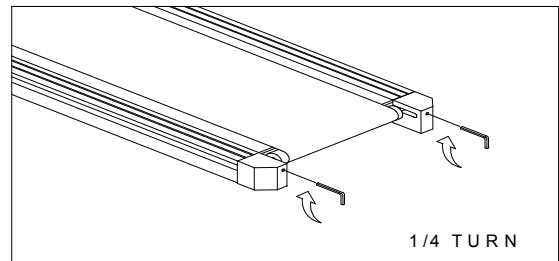

If Treadbelt shifts too far to the right

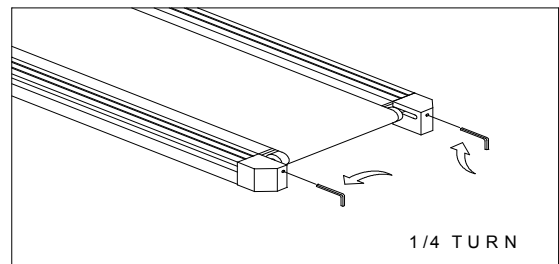

If Treadbelt shifts too far to the left

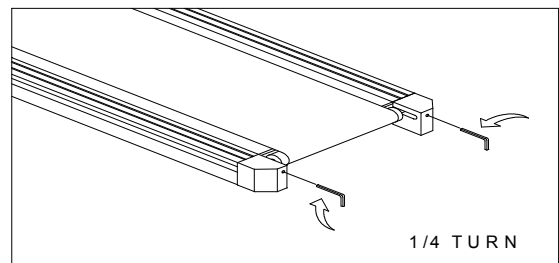

TREADMILL LUBRICATION

Your treadmill should require little maintenance other than periodically applying lubricant. Lubricating under the treadbelt will ensure superior performance and extend its life expectancy.

HOW TO CHECK TREADBELT FOR PROPER LUBRICATION

Lift one side of the treadbelt and feel the top surface of the treadboard

If the surface is (slick) to the touch, then no further lubrication is required

If the surface is dry to the touch, apply one packet of lubricant or half of the bottle of lubricant.

HOW TO APPLY LUBRICANT

1. Loosen the rear roller adjusting bolts (81) one full turn counterclockwise. This will loosen the treadbelt.
2. Lift one side of the treadbelt.
3. Pour one half of the lubricant bottle under the center of the treadbelt on the top surface of the treadboard.
4. Tighten the rear roller adjusting bolts (81) one full turn clockwise. This will tighten the treadbelt.
5. Walk on the treadmill at a slow speed for 3 to 5 minutes to evenly distribute lubricant.

NOTE: DO NOT over lubricate treadboard. Any excess lubricant that comes out should be wiped off.

IMPORTANT: ONLY USE HALF THE BOTTLE OF LUBRICANT PER APPLICATION LUBRICATION SCHEDULE

1. After the first 25 (hours) apply one half bottle of lubricant.
2. Every 30 hours of use apply one half bottle of lubricant.

We recommend that you use:

Lube-N-Walk™ Treadmill Lubrication Kit.

CLEANING AND MAINTENANCE

Care has been taken to assure that your treadmill has been properly adjusted and lubricated at the factory. It is not recommended that the user attempt service on the internal components instead seek service from an authorized service center. However, from time-to-time the outer surfaces may appear dull or dirty, following the instructions listed below will restore and preserve the original finish.

Note: Always unplug your treadmill prior to cleaning in order to avoid electrical hazard or shock.

1. Cleaning metal surfaces may be accomplished by using a soft cotton or terry cloth rag with a light application of car wax. Do not use aerosol sprays or pump bottles as they may deposit wax upon the walking or computer surface.
2. Under no circumstances are you to use ammonia, oils, silicones, or any other compounds on the rubberized walking surface. The use of such materials may cause serious injury to the body and/or deteriorate the performance of the walking surface. Only clean the rubberized walking surface with a damp cloth (water only).
3. From time-to-time the computer surface may collect dust or finger prints. The use of harsh chemicals will destroy the protective coating and cause a static build up that will damage the components. This surface may be cleaned with specially prepared chemicals found in most computer supply stores especially made for anti-static surfaces. It is strongly recommended that you purchase such a cleaning compound.

RESET SWITCH RESETTING

If your treadmill loses power or will not start, check the reset switch located on the front of the motor cover.

If the white tab of the reset switch is not showing then the reset switch has not been tripped.

If the white tab of the reset switch is showing, the reset switch has tripped.

To reset the reset switch:

Remove the safety clip on console.

Press white tab of the reset switch in until it snaps back into place.

If the reset switch continues to trip - see treadmill adjustment and treadmill lubrication

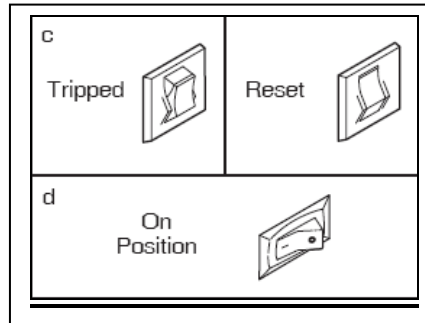

SPEED SENSOR ADJUSTMENT

If the monitor does not display speed or distance the speed sensor and magnet may be misaligned.

Note: Always unplug your treadmill prior to cleaning in order to avoid electrical hazard or shock.

Follow these steps to check and realign.

Remove the motor cover

Check the spacing and alignment between the magnet on the right side of the front roller and the speed sensor on the frame. The spacing must be 1/8".

Loosen screw and slide speed sensor in or out of clamp.

Retighten screw.

Replace motor cover

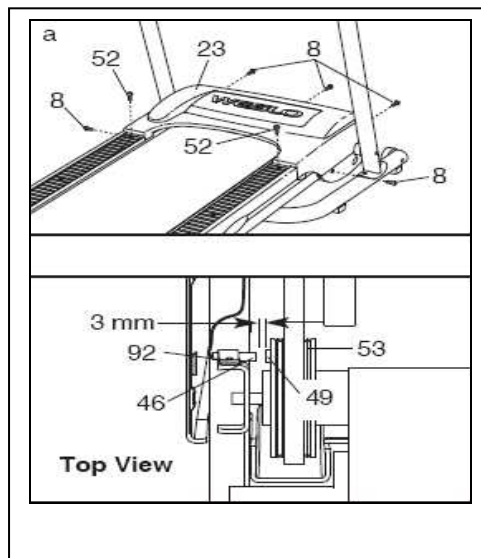

TRAINING GUIDELINES

Exercise is one of the most important factors in the overall health of an individual. Listed among its benefits are:

- Increased capacity for physical work (strength endurance)
- Increased cardiovascular (heart and arteries/veins) and respiratory efficiency
- Decreased risk of coronary heart disease
- Changes in body metabolism, e.g. losing weight
- Delaying the physiological effects of age
- Physiological effects, e.g. reduction in stress, increase in self-confidence, etc.

Basic Components of Physical Fitness

There are four all encompassing components of physical fitness and we need to briefly define each and clarify its role.

Strength is the capacity of a muscle to exert a force against resistance. Strength contributes to power and speed and is of great importance to a majority of sports people.

Muscular Endurance is the capacity to exert a force repeatedly over a period of time, e.g. it is the capacity of your legs to carry you 10 Km without stopping.

Flexibility is the range of motion about a joint. Improving flexibility involves the stretching of muscles and tendons to maintain or increase suppleness, and provides increased resistance to muscle injury or soreness.

Cardio-Respiratory Endurance is the most essential component of physical fitness. It is the efficient functioning of the heart and lungs.

Aerobic Fitness

The largest amount of oxygen that you can use per minute during exercise is called your **maximum oxygen uptake** (MVo₂). This is often referred to as your **aerobic capacity**.

The effort that you can exert over a prolonged period of time is limited by your ability to deliver oxygen to the working muscles. Regular vigorous exercise produces a training effect that can increase your aerobic capacity by as much as 20 to 30%. An increased MVO₂ indicates an increased ability of the heart to pump blood, of the lungs to ventilate oxygen and of the muscles to take up oxygen.

Anaerobic Training

This means “without oxygen” and is the output of energy when the oxygen supply is insufficient to meet the body’s long term energy demands. (For example, 100 meter sprint).

The Training Threshold

This is the minimum level of exercise which is required to produce significant improvements in any physical fitness parameter.

Progression

As you become fitter, a higher intensity of exercise is required to create an overload and therefore provide continued improvement

Overload

This is where you exercise at a level above that which can be carried out comfortably. The intensity, duration and frequency of exercise should be above the training threshold and should be gradually increased as the body adapts to the increasing demands. As your fitness level improves, the training threshold should be raised. Working through your program and gradually increasing the overload factor is important.

Specificity

Different forms of exercise produce different results. The type of exercise that is carried out is specific both to the muscle groups being used and to the energy source involved. There is little transfer of the effects of exercise, i.e. from strength training to cardiovascular fitness. That is why it is important to have an exercise program tailored to your specific needs.

Reversibility

If you stop exercising or do not do your program often enough, you will lose the benefits you have gained. Regular workouts are the key to success.

Warm Up

Every exercise program should start with a **warm up** where the body is prepared for the effort to come. It should be gentle and preferably use the muscles to be involved later.

Stretching should be included in both your **warm up** and **cool down**, and should be performed after 3-5 minutes of low intensity aerobic activity or callisthenic type exercise.

Warm Down or Cool Down

This involves a gradual decrease in the intensity of the exercise session. Following exercise, a large supply of blood remains in the working muscles. If it is not returned promptly to the central circulation, pooling of blood may occur in the muscles.

Heart Rate

As you exercise, the rate at which your heart beat increases. This is often used as a measure of the required intensity of exercise. You need to exercise hard enough to condition your circulatory system, and increase your pulse rate, but not enough to strain your heart.

Your initial level of fitness is important in developing an exercise program for you. If you are starting off, you can get a good training effect with a heart rate of 110-120 beats per minute(BPM). If you are fitter, you will need a higher threshold of stimulation.

To begin with, you should exercise at a level that elevates your heart rate to about 65 to 70% of your maximum. If you find this is too easy, you may want to increase it, but it is better to lean on the conservative side.

As a rule of thumb, the maximum heart rate is 220 minus your age. As you increase in age, your heart, like other muscles, loses some of its efficiency. Some of its natural loss is won back as fitness improves.

The following table is a guide to those who are “starting fitness”.

Age	25	30	35	40	45	50	55	60	65
10Second Count	23	22	22	21	20	19	19	18	18
Beats per Minute	138	132	132	126	120	114	114	108	108

Pulse Count

The pulse count (on your wrist or carotid artery in the neck, taken with two index fingers) is done for ten seconds, taken a few seconds after you stop exercising. This is for two reasons: (a) 10 seconds is long enough for accuracy, (b) the pulse count is to approximate your BPM rate at the time you are exercising. Since heart rate slows as you recover, a longer count isn't as accurate.

The target is not a magic number, but a general guide. If you're above average fitness, you may work quite comfortably a little above that suggested for your age group. The following table is a guide to those who are keeping fit. Here we are working at about 80% of maximum.

Age	25	30	35	40	45	50	55	60	65
Target heart Rate									
10 Second Count	26	26	25	24	23	22	22	21	20
Beats per Minute	156	156	150	144	138	132	132	126	120

Don't push yourself too hard to reach the figures on this table. It can be very uncomfortable if you overdo it. Let it happen naturally as you work through your program. Remember, the target is a guide, not a rule, a little above or below is just fine.

Two final comments:(1) don't be concerned with day to day variations in your pulse rate, being under pressure or not enough sleep can affect it;(2) your pulse rate is a guide, don't become a slave to it.

Muscle Soreness

For the first week or so, this may be the only indication you have that you are on an exercise program. This, of course, does depend on your overall fitness level. A confirmation that you are on the correct program is a very slight soreness in most major muscle groups. This is quite normal and will disappear in a matter of days.

If you experience major discomfort, you may be on a program that is too advanced or you have increased your program too rapidly.

If you experience PAIN during or after exercise, your body is telling you something. Stop exercising and consult your doctor.

What to Wear

Wear clothing that will not restrict your movement in any way while exercising. Clothes should be light enough to allow the body to cool. Excessive clothing that causes you to perspire more than you normally would while exercising, gives you no advantage. The extra weight you lose is body fluid and will be replaced with the next glass of water you drink. It is advisable to wear a pair of gym or running shoes or "sneakers".

Breathing during Exercise

Do not hold your breath while exercising. Breathe normally as much as possible. Remember, breathing involves the intake and distribution of oxygen, which feeds the working muscles.

Rest periods

Once you start your exercise program, you should continue through to the end. Do not break off halfway through and then restart at the same place later on without going through the warm-up stage again.

The rest period required between strength training exercises may vary from person to person. This will depend mostly on your level of fitness and the program you have chosen. Rest between exercises by all means, but do not allow this to exceed two minutes. Most people manage with half minute to one minute rest periods

STRETCHING

Stretching should be included in both your warm up and cool down, and should be performed after 3-5 minutes of low intensity aerobic activity or callisthenic type exercise. Movements should be performed slowly and smoothly, with no bouncing or jerking. Move into the stretch until slight tension, not pain, is felt in the muscle and hold for 20-30 seconds. Breathing should be slow, rhythmical and under control, making sure never to hold your breath.

HEAD ROLLS

Rotate your head to the right for one count, feeling the stretch up the left side of your neck. Next rotate your head back for one count, stretching your chin to the ceiling and letting your mouth open. Rotate your head to the left for one count, and finally, drop your head to your chest for one count.

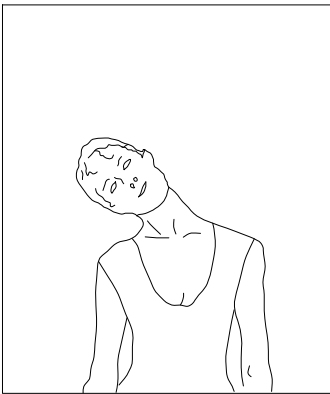

SHOULDER LIFTS

Lift your right shoulder up toward your ear for one count. Then lift your left shoulder up for one count as you lower your right shoulder.

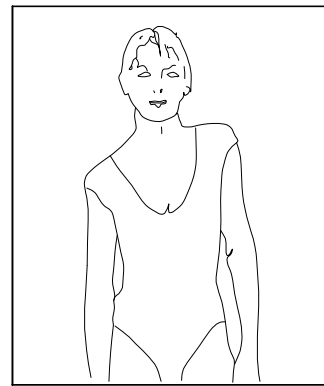

SIDE STRETCHES

Open your arms to the side and continue lifting them until they are over your head. Reach your right arm as far upward toward the ceiling as you can for one count. Feel the stretch up your right side. Repeat this action with your left arm.

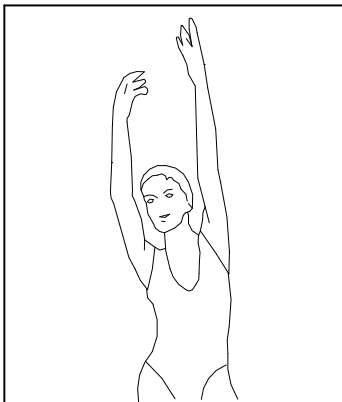

QUADRICEPS STRETCH

With one hand against a wall for balance, reach behind you and pull your right foot up. Bring your heel as close to your buttocks as possible. Hold for 15 counts and repeat with left foot up.

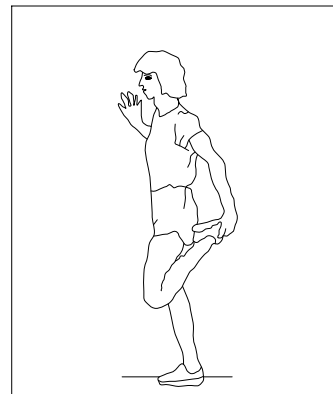

INNER THIGH STRETCH

Sit with the soles of your feet together with your knees pointing outward. Pull your feet as close into your groin as possible. Gently push your knees towards the floor. Hold for 15 counts.



TOE TOUCHES

Slowly bend forward from your waist, letting your back and shoulders relax as you stretch toward your toes. Reach down as far as you can and hold for 15 counts.

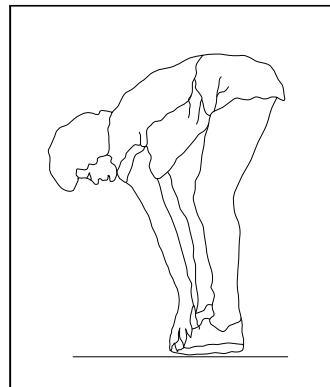

HAMSTRING STRETCHES

Sit with your right leg extended. Rest the sole of your left foot against your right inner thigh. Stretch toward your toe as far as possible. Hold for 15 counts. Relax and then repeat with left leg extended.

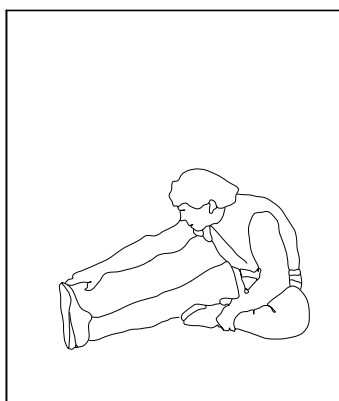

CALF / ACHILLES STRETCH

Lean against a wall with your left leg in front of the right and your arms forward. Keep Your right leg straight and the left foot on the floor, then bend the left leg and lean forward by moving your hips toward the wall. Hold, then repeat on the other side for 15 counts.

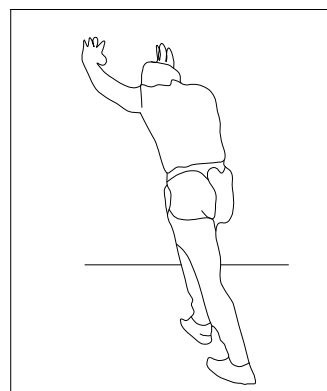

WARRANTY

LIMITED WARRANTY, REPAIR AND SERVICE

WHAT DOES THIS WARRANTY COVER? This warranty covers your Progression against defects in material and workmanship when used for the purpose intended, under normal conditions and provided it receives proper care.

HOW LONG DOES THE COVERAGE LAST? This warranty lasts for two years on labour from date of purchase, 5 years on parts and lifetime on the motor and lifetime on the frame. This warranty is not transferable and is extended only to the original owner.

WHAT WILL FLAMAN SALES LTD. DO? FLAMAN SALES LTD. will provide a replacement part and/or service at no charge for any part found defective in workmanship or materials during the warranty period.

HOW DO YOU GET SERVICE? In order to obtain replacement parts or service as provided by this warranty, you may call the number below: 1-866-978-1999 Monday to Friday 8:30 a.m. to 5:00 p.m. central standard time.

To activate your warranty, you must send in your warranty registration card.

This warranty shall not apply to treadmills which are (1) used for commercial or other income producing purpose, or (2) subject to misuse, neglect, accident or unauthorized repairs and alterations

This warranty provided herein is in lieu of all other express warranties. Any implied warranties, including any implied warranties of merchantability or fitness for particular purpose are limited in duration to the first 12 months from the date of purchase. All other obligations or liabilities, including liability for consequential damages are hereby excluded

All of the parts for the Leisure Works Treadmill, shown in figure can be ordered from: FLAMAN SALES LTD. 120 Robin Cres, Saskatoon, Saskatchewan, S7L 3M7. When ordering parts, the parts will be sent and billed at the current prices. Prices may be subject to change without notice. Check or money order must accompany all orders. Standard hardware items are available at your local hardware store.

To ensure prompt and correct handling of any errors, or to answer any questions, please call our Toll Free number, 1-866-978-1999, or email us at customerservice@flaman.com. Office hours are from 8:30 A.M. to 5:00 P.M. Monday to Friday Central Standard time.

Always include the following information when ordering parts:

- *Model number
- *Name of each part
- *Part number of each part