



Mobia™

by **NAUTILUS**



Owner's Manual

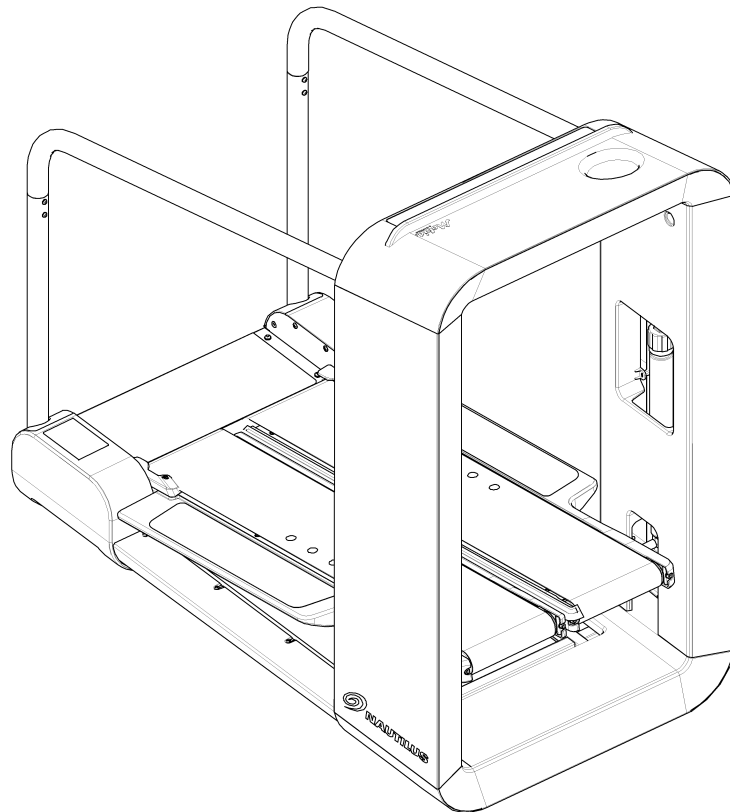

English

Nautilus®

Bowflex®

Schwinn® Fitness

StairMaster®

Universal®

Table of Contents

Contacts	2	Remote Heart Rate Monitor	7
Important Safety Instructions	2	Adjustments	8
Safety Warning Labels and Serial Numbers	3	Maintenance	10
Features	4	Moving Your Machine	11
Specifications	4	Troubleshooting	12
Operations	5		
Console	5		

www.mobia.com/quickstart

View this web site for a “getting started” video, assembly tips, and the latest accessories for your Mobia™ fitness machine.

Nautilus, Inc., World Headquarters, 16400 SE Nautilus Dr. Vancouver, WA, USA 98683, (800) NAUTILUS / (800) 628-8458, www.NautilusInc.com - Customer Service: North America (800) 605-3369, tcinquiries@nautilus.com | Europe, Middle East & Africa 49 02203 2020 0, technics@nautilus.com | Germany & Austria + 49 02203 2020 0, Switzerland + 41 26 460 77 66, United Kingdom + 44 1908 267 345, Asia Pacific & Latin America (360) 859-5180, technics-APLA@nautilus.com | Patent information: This product may be covered by US and Foreign Patents and Patents Pending. See Product for more information. | Printed in China | © 2009 Nautilus, Inc., All rights reserved. ™ and ® indicate a trademark or registered trademark. Nautilus, Inc. (www.nautilus.com) trademarks include NAUTILUS®, BOWFLEX®, STAIRMASTER®, SCHWINN® and UNIVERSAL® and respective logos. Other trademarks are the property of their respective owners.

To validate warranty support record the following information: Serial Number _____ Date of Purchase _____

Important Safety Instructions

 This icon means a potentially hazardous situation which, if not avoided, could result in death or serious injury. Before using this equipment, obey the following warnings:

- **⚠ DANGER** To reduce the risk of electrical shock, always unplug the power cord and wait 5 minutes before cleaning, maintaining or repairing this machine. • To decrease the risk of burns, electric shock, or injury to persons, read and understand the complete Owner's Manual. Failure to follow these guidelines can cause a serious or possibly fatal electrical shock or other serious injury. Keep Owner's Manual for future reference. • Read and understand all warnings on this machine. If at any time the Warning stickers become loose, unreadable or dislodged, contact Nautilus® Customer Service for replacement stickers. • Children must not be let on or near to this machine. Moving parts and other features of the machine can be dangerous to children. • Consult a physician before you start an exercise program. Stop exercising if you feel pain or tightness in your chest, become short of breath, or feel faint. Contact your doctor before you use the machine again. Use the values calculated or measured by the machine's computer for reference purposes only. • Before each use, examine this machine for damage to power cord, power receptacle, loose parts or signs of wear. Do not use if found in this condition. Contact Nautilus® Customer Service for repair information. • Maximum user weight limit: 300 lbs. (136 kg). Do not use if you are over this weight. • This machine is for home use only. • Do not wear loose clothing or jewelry. This machine contains moving parts. • Always wear rubber soled athletic shoes when you use this machine. Do not use the machine with bare feet or only wearing socks. • Set up and operate this machine on a solid, level, horizontal surface. • Use caution when you step on and off the machine. Use the supplied foot support platforms for stability before walking on the moving belt. • Do not operate this machine outdoors or in moist or wet locations. • Keep at least 19.5" (1/2 m) on each side of the machine and 79" (2 m) behind the machine clear. This is the recommended safe distance for access and passage around and emergency dismounts from the machine. Keep third parties out of this space when machine is in use. • Do not over exert yourself during exercise. Operate the machine in the manner described in this manual. • Read, understand, and test the Emergency Stop Procedure before use. • Keep the walking belt clean and dry. • Keep power cord away from heat source and hot surfaces. • Do not drop or put objects into any opening of the machine. • This machine must be connected to an appropriate, dedicated electrical circuit. Nothing else must be connected to the circuit. • Always connect the power cord to a circuit capable of handling 10 amperes with no other loads applied. • Do not operate where aerosol products are being used. • Do not let liquids touch the electronic controller. If it does, the controller must be inspected and tested for safety by an approved technician before it can be used again. • This machine is designed for walking. Do not try to run on this machine.

Emergency Stop Procedures

The Mobia™ fitness machine is equipped with a Safety Key that can prevent serious injury, as well as prevent children from playing with and/or being injured on the machine. If the Safety Key is not fully put into the Safety Key Port, the belts will not operate.



To prevent unsupervised operation of the machine always remove the Safety Key and disconnect the power cord from the wall outlet or machine AC input.

Always attach the Safety Key Clip to your clothing during your workout.

When you use the machine, only remove the Safety Key in an emergency. When the key is removed while the machine is in operation, it will stop quickly, which could cause the loss of balance and possible injury.

For safe storage of the machine and to prevent unsupervised operation of the machine always remove the Safety Key and disconnect the power cord from the wall outlet or machine AC input.

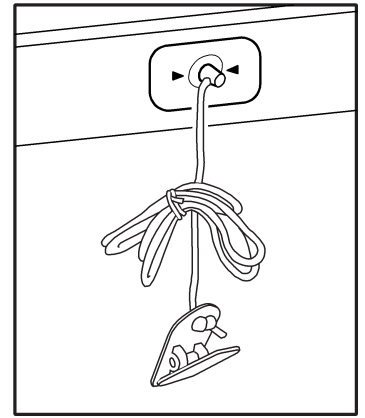

The Console will display “EStP” for a Safety Key fault. Inspect the Safety Key and be sure it is connected to the Console correctly. Push START to reset the Console.

Grounding Instructions

This product must be grounded. If it should malfunction or break down, grounding gives a path of least resistance for electrical current, to decrease the risk of electric shock. The power cord is equipped with an Equipment-grounding Conductor and a grounding plug. The plug must be connected to an outlet that is correctly installed and grounded. The electrical wiring must obey the applicable local and provincial requirements.



Incorrect connection of the equipment-grounding conductor can result in a risk of electric shock. Consult a licensed electrician if you are not sure if the machine is correctly grounded. Do not change the plug on the machine – if it does not fit the outlet, have a correct outlet installed by a licensed electrician.

It is recommended to use a dedicated circuit for this machine. This means that no other equipment is connected to the same outlet. If a surge protector is used with this machine, make sure that it is a heavy duty model with 10 or 12 AWG wire.

Safety Warning Labels and Serial Number

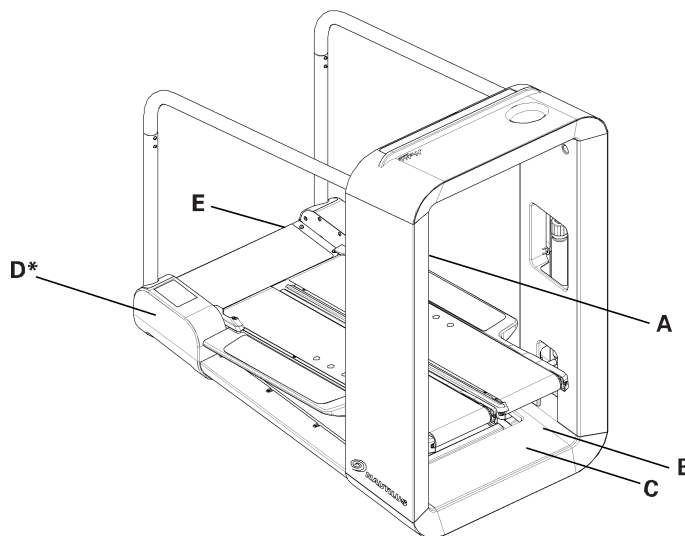

Type	Description
A WARNING	<p>Failure to obey these safeguards can cause serious injury or health problems.</p> <ol style="list-style-type: none"> 1. Keep children and pets away from this machine at all times. 2. When this machine is not in operation, remove the Safety Key and keep out of the reach of children. 3. Use Caution when you operate this equipment or serious injury can occur. 4. Prior to use, read and understand the Owner's Manual, including all Warnings. 5. To prevent injury, stand on the Foot Platforms before you start the machine. 6. This machine is for Residential use only. 7. The Maximum user Weight for this machine is 300lbs./136kgs. 8. Replace any Warning label that becomes damaged, illegible or is removed.

B	Serial Number	Record serial number on Contacts page at end of this manual.
C	CAUTION	Unplug power cord before you move the machine.
D*	WARNING	Hazardous Voltage Contact may cause electrical shock or burn. Turn off and lock out power before servicing.
E	WARNING	Moving parts can crush and cut. Keep guards in place. Lock out power before servicing.

* decal is located under cover

Features

A	Safety Key Port	H	Levelers
B	Console	I	Walking Belt
C	Water Bottle Holder	J	Side Foot Support Platform
D	Workout Setting Cylinders	K	Power Switch
E	Belt Adjustment Bolts	L	Transport Wheels
F	Treadles	M	Rear Step
G	Transport Handle	N	Hand Bar

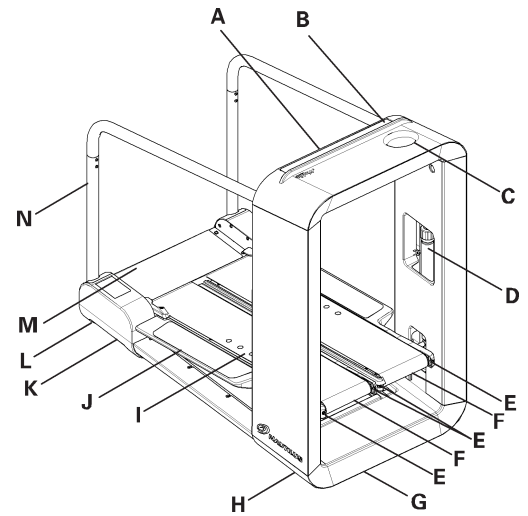

Specifications

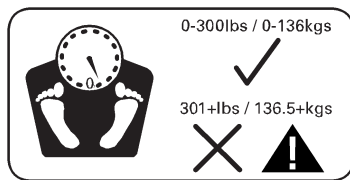

Assembled Weight

approx. 200 lbs. (90.7 kg)

Power Requirements

Operational Voltage

120V AC 60 Hz.

Operating Current

10A max

Regulatory Approvals

c-ETL-us mark. Evaluated per UL 1647 Fourth Edition, January 2008 and CAN/CSA-C22.2. 68-92.

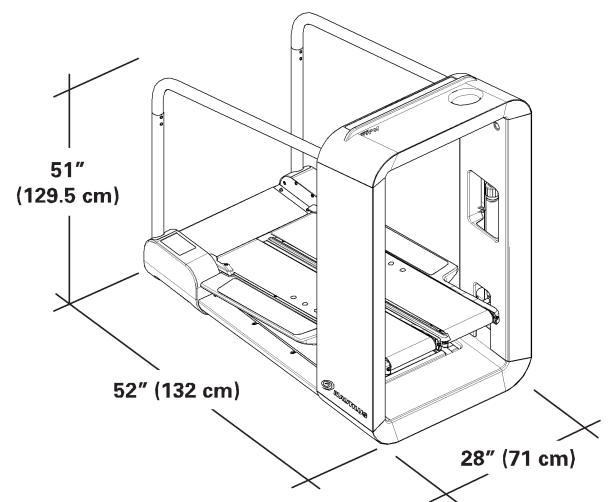

Operations

Before You Start

1. Place the Mobia™ fitness machine in your workout area.

! Place the machine on a clean, hard, level surface, free from unwanted material or other objects that may hamper your ability to move freely. A rubber mat can be used below the machine to prevent the release of static electricity and protect your flooring.

The machine can be moved by one or more persons. Make sure that your own physical strength is capable of moving the machine.

2. Adjust the intensity settings on the Workout Setting Cylinders.

Note: Initially, the settings on each cylinder should match. If Treadle movement is unequal, adjust the setting of one cylinder to compensate.

3. If you use the Heart Rate Monitor, follow the heart rate transmitter chest strap directions.
4. Connect the power cord to the machine and into a grounded AC Wall Outlet.

Note: The Mobia™ fitness machine is designed to plug directly into a properly wired and grounded three prong 120V outlet. If an extension cord must be used, be sure it is a heavy duty, 10 or 12 AWG wire.

! Put the power cord alongside the machine, out of your way when you dismount the machine. Prevent stepping on the power cord and plug.

5. Switch on the power. Power is now supplied to the motor and Console.
6. Straddle the belts and stand on the Side Foot Support Platforms. Put the Safety Key into the Safety Key Port and attach the Safety Key Clip to your clothing.
 - To energize the Drive Belt Motor, the Safety Key must be correctly put into the Safety Key Port.
 - Always attach the Safety Key Clip to your clothing during workouts.
 - If there is an emergency, pull out the Safety Key to shut off the power to the belts. This will abruptly stop them (brace yourself—this is an abrupt stop).
7. Start your workout when the belts are up to speed.

! Keep your hands on the support Hand Bars and stay as near the front of the machine as is comfortable in order to stay in balance on the Treadles.

Keep your foot in the center of each Treadle, do not let your feet cross in front of your body as you increase the speed.

When you are experienced and comfortable with the action of the machine, allow your arms to swing freely in a natural walking motion. This workout will activate your core muscles. It should only be done by those comfortable with not holding on to the Hand Bars.

Console

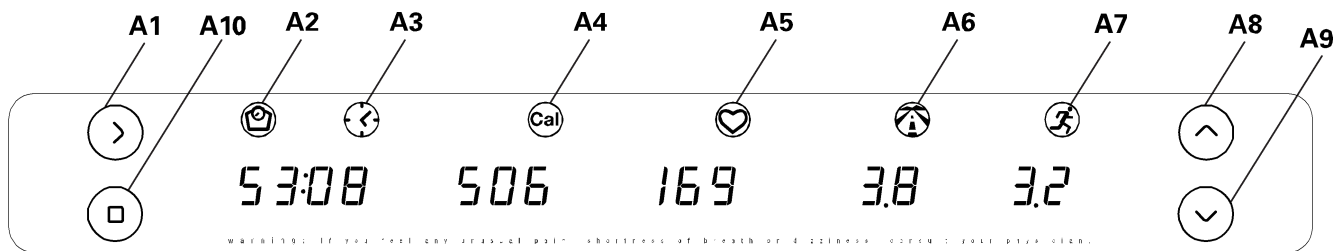

A1	START button	Push to begin a workout or to enter information.
A2	Weight display	Displays when you input your weight for a Custom Workout.
A3	Time display	Counts in minutes and seconds the total time of your workout (e.g. 24:22 minutes). During a Quick Start workout, the Time display will count up from "00:00". For a Set Time workout, the Time display will count down.
A4	Calorie display	Counts your total calories burned. Note: When you reach "999", the Calorie display will rollover to a value of "000".
A5	Heart Rate display	Shows your heart rate in beats per minute when you correctly wear the heart rate transmitter chest strap. On detection of a heart rate signal, three horizontal dashes will flash as the heart rate value is calculated. Note: The HR (Heart Rate) display will be blank if no signal is detected for 10 seconds.
A6	Distance display	Shows your workout distance in miles or kilometers. Miles is the default setting. Note: When you workout a distance more than "9.99", the decimal will adjust to "10.0".

A7	Speed display	Shows your climbing rate in miles (MPH) or kilometers (KPH) per hour to one decimal (e.g. 3.2 MPH). MPH is the default setting.
A8	Increase ▲ button	Push to increase the speed of the belts, increase a value for weight and time, or scroll through a list of values.
A9	Decrease ▼ button	Push to lower the speed of the belts, decrease a value for weight and time, or scroll through a list of values.
A10	STOP button	Push to pause a workout, push again to end it.

Power Up Mode

The Console will enter Power Up mode when initially plugged into a power source and any button is pushed.



The belts will only move after a 3 second, audible beep countdown.

Quick Start

With power supplied to the machine, you can begin a Quick Start workout. Simply push the START button. After a three second, audible countdown, the quick start workout will begin.

Note: Be sure to read the “Before You Start” section of your manual.

The Console will display “ESTP” for a Safety Key fault. Examine the Safety Key and be sure it is connected to the Console correctly. Push START to reset the Console.

Custom Workout

The Console allows you to customize a workout with your weight and length of workout. With your weight, the Console can be more accurate with your calorie count. Push and hold down the START button for 2 seconds. The Console will display the default weight of 150 pounds (68 kg) or the last weight entered. Use the Increase and Decrease buttons to adjust the value. When correct, push the START button. Your weight is set and will be the default value until changed.

The default workout time of 30 minutes or the last time entered will then be shown. Adjust the workout time with the Increase and Decrease buttons, and push START. This will be the new default workout time.

Pausing or Stopping

1. With a firm hold on the Hand Bars, step off of the belts and onto the Side Foot Support Platforms on either side of the Treadles.
2. Push STOP to pause the workout. The belts will slow to a complete stop.

Note: If a paused workout is not restarted in 5 minutes, the machine will shut down and clear all workout values.

3. To restart your workout, push the START button. To end your workout, press STOP again. The Console will display your results.



To prevent unsupervised operation of the machine always remove the Safety Key and disconnect the power cord from the wall outlet or machine AC input.

Results

When a workout ends, the Console will show the results. Your results are shown in the sequence (time, calories, average heart rate, distance, and average speed) three times.

Shut Off (Sleep Mode)

If the Console does not receive any input for five minutes, it will automatically shut off. All workout values are cleared in Sleep Mode.

Note: The Console does not have an On/Off switch.

Push the START button to start (wake up) the Console.

Service / Setup Mode

The Console has a Service / Setup Mode. Some options in the Service / Setup Mode can be adjusted to your preferences, but most are helpful for service of the machine. To access the Service / Setup Mode, hold down the ▲ and ▼ buttons for 2 seconds.

Order	Option	Description
1	Units	Select your preferred unit of measurement; “Lb” = English Imperial, “M” = metric
2	Intensity	Control the brightness level of the Console; “4” = maximum intensity, “1” = minimum
3	Error Log *	Displays error codes, starting with the most recent
4	Console Version *	Displays the software version
5	Drive Version *	Displays the drive version
6	Device Usage	Displays total number of hours used
7	Device Mileage	Displays total mileage
8	Motor Current History *	Displays the last five maintenance intervals, starting with the most recent

9	Hardware Type *	Displays the hardware type
10	Motor Current *	Displays the current of the motor
11	Coast Time *	A test to see how long until the belts stop.

*for Service Technicians

Use the ▲ and ▼ buttons to cycle through the Options, and push the START button to execute your selected Option.

Push STOP to exit the Service / Setup Mode.

Remote Heart Rate Monitor

Monitoring your Heart Rate is one of the best procedures to control the intensity of your exercise.

A Heart Rate Chest Strap Transmitter is included to send your Heart Rate signals to the Console. The Console displays your Heart Rate in Beats Per Minute (BPM).

! If you have a pacemaker or other implanted electronic device, consult your doctor before using a wireless chest strap or other telemetric heart rate monitor.

Chest Strap

Using the heart rate transmitter chest strap lets you monitor your heart rate at any time during your workout.

! Consult a physician before you start an exercise program. Stop exercising if you feel pain or tightness in your chest, become short of breath, or feel faint. Contact your doctor before you use the machine again. Use the values calculated or measured by the machine's computer for reference purposes only.

The heart rate transmitter is attached to a chest strap to keep your hands free during your workout. Attach the transmitter to the elastic chest strap.

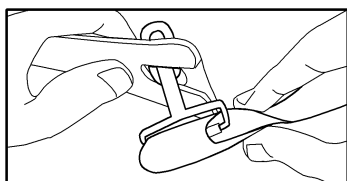

Adjust the strap length to fit snugly and comfortably against your skin. Secure the strap around your chest, just below the chest muscles, and buckle it.

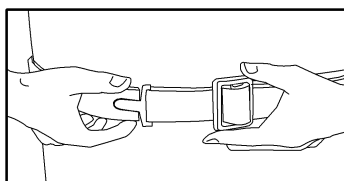

Lift the transmitter off your chest and moisten the two Grooved Electrode Areas on the back.

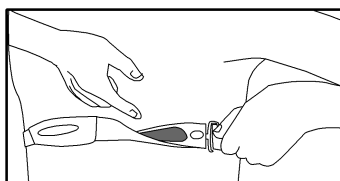

Check that the wet electrode areas are firmly against your skin.

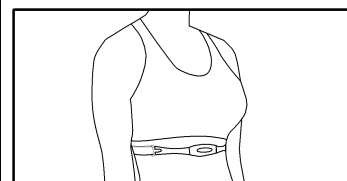

The transmitter will send your heart rate to the machine's receiver and display your Beats Per Minute (BPM).

Always remove the transmitter before you clean the chest strap. Clean the chest strap regularly with mild soap and water, and thoroughly dry it. Residual sweat and moisture keep the transmitter active and drain the battery in the transmitter.

Note: Do not use abrasives or chemicals such as steel wool or alcohol when you clean the chest strap, as they can damage the electrodes permanently.

If the Console does not display a heart rate value, the transmitter may be at fault. Check that the textured contact areas on the chest strap are contacting with your skin. You may need to lightly wet the contact areas. If no signal appears or you need further assistance, call your Nautilus® Representative.

Heart Rate Calculations

Your maximum heart rate usually decreases from 220 Beats Per Minute (BPM) in childhood to approximately 160 BPM by age 60. This fall in heart rate is usually linear, decreasing by approximately one BPM for each year. There is no indication that training influences the decrease in maximum heart rate. Individuals of the same age could have different maximum heart rates. It is more accurate to find this value by getting a stress test than by using an age related formula.

Your at rest heart rate is influenced by endurance training. The typical adult has an at rest heart rate of approximately 72 BPM, where as highly trained runners may have readings of 40 BPM or lower.

The Heart Rate table is an estimate of what Heart Rate Zone (HRZ) is effective to burn fat and better your cardiovascular system. Physical conditions vary, therefore your individual HRZ could be several beats higher or lower than what is shown.

The most efficient procedure to burn fat during exercise is to start at a slow pace and gradually increase your intensity until your heart rate reaches between 60 – 85% of your maximum heart rate. Continue at that pace, keeping your heart rate in that target zone for over 20 minutes. The longer you maintain your target heart rate, the more fat your body will burn.

The graph is a brief guideline, describing the generally suggested target heart rates based on age. As noted above, your optimal target rate may be higher or lower. Consult your physician for your individual target heart rate zone.

Note: As with all exercises and fitness regimens, always use your best judgment when you increase your exercise time or intensity.

Fat Burning Target Heart Rate

Heart Rate BPM (beats per minute)

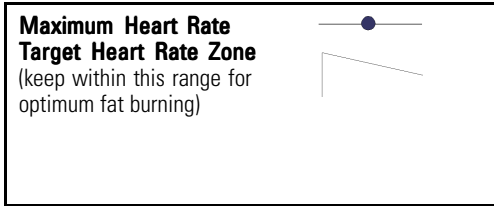
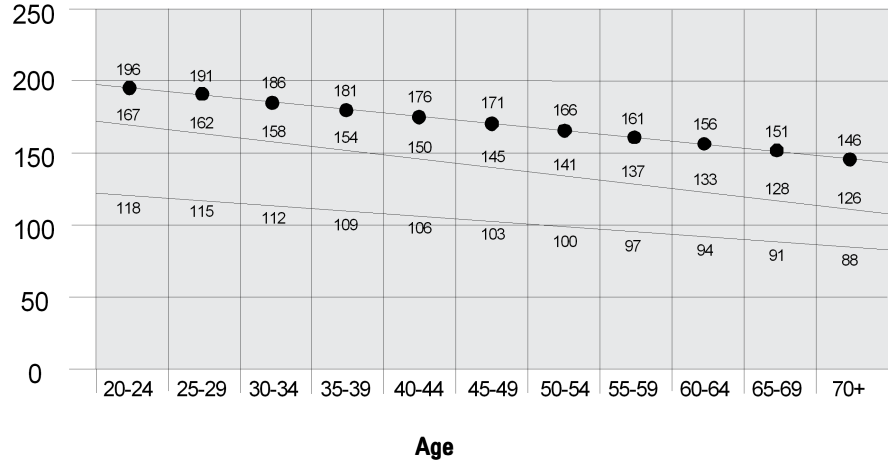

Adjustments

Workout Setting Cylinders

Your Mobia™ fitness machine uses Hydraulic Resistance Cylinders to absorb your steps and cushion your joints, decreasing your overall fatigue and reducing muscle strain. The intensity of a workout can be subtly adjusted through the Workout Intensity Settings. These add a slight level of control to the resistance of the cylinders.

The Workout Intensity Settings dial is found at the top of the Hydraulic Cylinders. Use the dials to line up the setting with the white arrow. The settings for both cylinders should match initially.

As you progress with your exercise routine, it is common for one leg to be stronger than the other. If this causes the Treadle movement to be uneven, adjust the Intensity Setting of one cylinder to compensate.

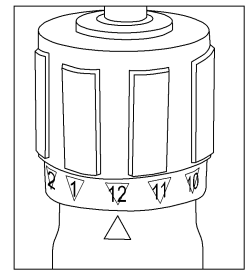

! Do not change the intensity settings of the Cylinders during a workout. Stop the workout and step off the machine before you adjust the resistance level.

Access to the cylinder settings dial is on the inside of the Upright Covers. Do not lean on the Treadles when you adjust the dials. The Treadles are not locked and will move. The higher the Workout Intensity Setting, the more the Treadle travels. A setting of 12 is more intense than a setting of 1. Although the Workout Intensity Settings dial can move continuously in either direction, it is recommended that you only turn the dial clockwise to setting 12 and counterclockwise to setting 1.

Note: “Bottoming out” occurs when the Treadle travels through too great a range of motion. When this occurs, the Treadles hit against the base on the down step. To reduce treadle travel, decrease the Workout Intensity Setting or increase belt speed.

Walking Belt Adjustment

The walking belts need to be adjusted if they are out of center enough to cause a rubbing or scraping sound. Adjustments can be made at the Front Roller of each Treadle.

Belt Alignment Check – Stand adjacent to the unit and set the speed to 1.5 MPH. The alignment adjustment bolts (see figure, item A) are on the front end of each Roller. If the belt is tracking too far to the right, use a properly sized Hex Key to turn the right adjustment bolt clockwise on that belt in full turn increments. If the belt tracks too far to the left, do the same thing on the left adjustment bolt.

Note: Do not turn the bolts counterclockwise when you adjust the belt alignment.

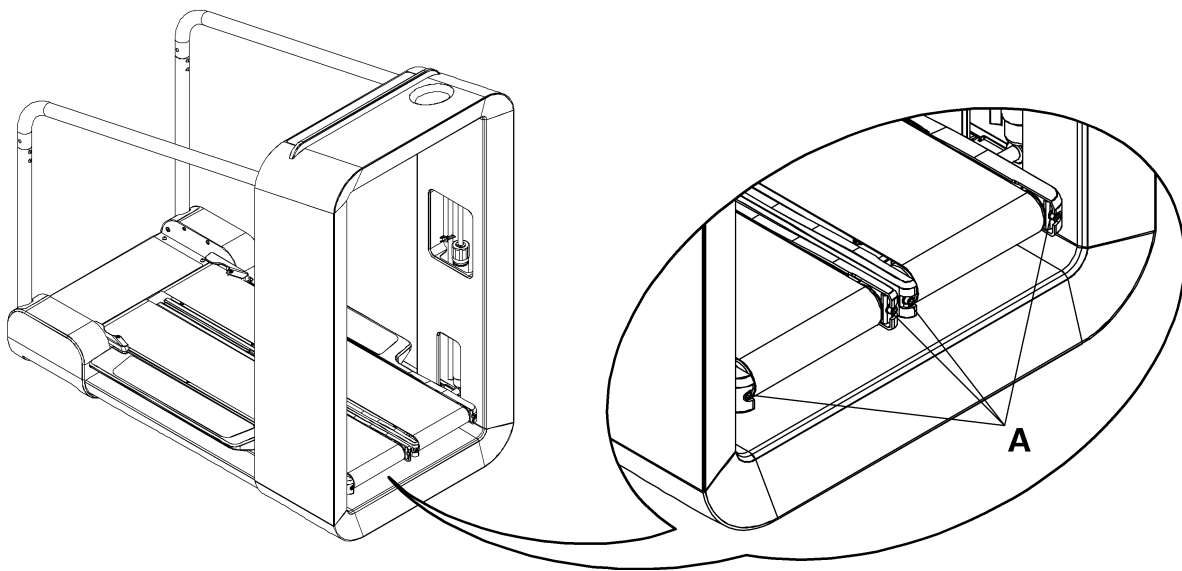

Belt Tension Check – Check the belt tension only when the machine is unplugged. From the belt’s midpoint, a correctly tensioned belt should only have 1” (2.5 cm) of give. To check, pull the belt upward at its midpoint and measure the distance to the deck. If the distance is more than 1” (2.5 cm), the belt is loose. To tighten, turn both bolts clockwise one-half a turn and check tension again. Repeat this step if necessary.

Note: Bolts are turned counterclockwise equally to decrease belt tension.

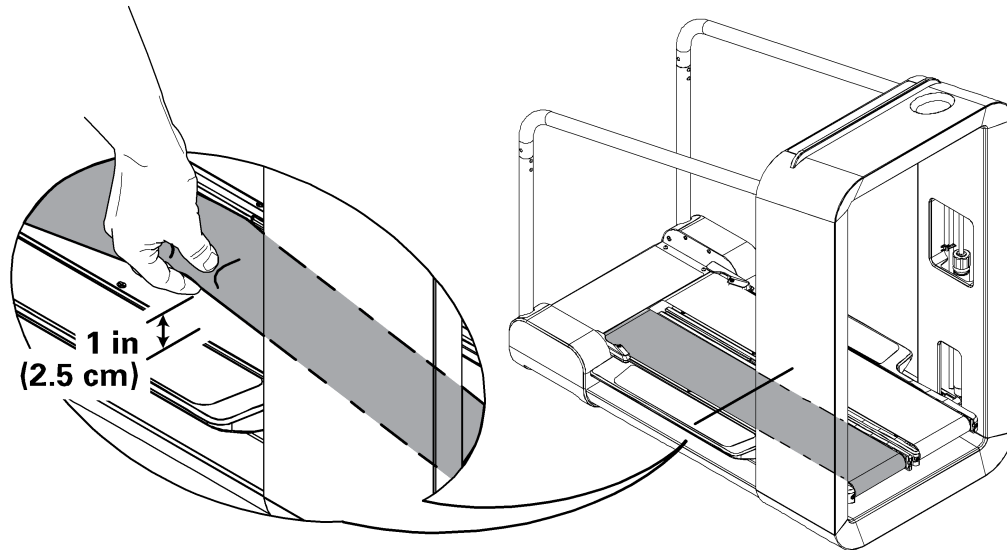

How Often Should You Exercise

! Consult a physician before you start an exercise program. Stop exercising if you feel pain or tightness in your chest, become short of breath, or feel faint. Contact your doctor before you use the machine again. Use the values calculated or measured by the machine’s computer for reference purposes only.

- 3 times a week for 30 minutes each day.
- You may not be able to complete 30 minutes of exercise at first. Gradually try to increase your workout time with each following session until you reach 30 minutes.
- For optimal results, combine your Mobia™ workouts with strength training and a sensible diet plan.
- Schedule workouts in advance. Try to work out even when you do not want to.

What to Wear

Wear rubber-soled athletic shoes. You will need the appropriate clothes for exercise that allow you to move freely.

Stretching

Stretch before you start your exercise session. Warm muscles respond better to exercise.

- Achilles Tendon and Calf - With both hands against a wall, place one foot behind you. Lean in toward the wall while keeping the rear leg straight and your heel on the ground. Repeat for the other leg.
- Quadriceps - Put your left hand on a wall or table for balance. Reach your right hand behind your back and grasp your right ankle. Pull it gently toward your buttocks until you feel tension along the front of your thigh. Repeat on the other side.
- Hamstring - Stand on one leg and prop the other leg parallel to the ground on a stable cabinet or table top. Slide both hands toward the propped up ankle as far as is comfortable. Repeat on other side.

Preliminary Workout

Follow these guidelines to ease yourself into a weekly exercise regimen. Use your judgment and/or the advice of your physician or health care professional to find the intensity and level of your workouts.

Warming Up

Before you start any workout, you should prepare your body for increased activity by slowly raising your heart rate.

Starting Your Workout

Interval Training and Steady State are 2 types of workouts that you can do on your Mobia™ fitness machine. You can also combine Interval Training with Steady State Training to get a varied workout.

Interval Training involves adjusting your speed for specific lengths of time to raise and lower your heart rate and calorie burn. Interval training changes the intensity of your workout during one exercise session. Alternating high-intensity training with low-intensity rest periods will boost your metabolism and help you burn calories after your workout is completed.

Interval training also helps prevent the injuries frequently associated with repetitive endurance exercise, and lets you increase your training intensity without over training or burning out. To develop a personal Interval Training regimen, change your belt speed or rate of stepping from fast speeds to slower recovery speeds.

The Steady State workout involves doing one exercise at the same speed and intensity for a long period of time. While there are risks to repetitive workouts, the Mobia™ machine is designed to cushion your joints and muscles from those stress injuries. Further, repetitive workouts can help you build your endurance, stamina and strength while you continue to hone and improve the tone and lean muscle mass in your long muscles.

	Beginner	Intermediate	Advanced
Week 1	<ul style="list-style-type: none"> • 3x per week, do a Mobia™ workout at stable, constant pace – 30 minutes <p>If this feels easier by the end of the week, move on to Week 2. If not, feel free to repeat the week.</p>	<ul style="list-style-type: none"> • 3x per week, do a Mobia™ workout at stable, constant pace for 30 minutes 	<ul style="list-style-type: none"> • 2 days interval training – 30 minutes • 1 day steady pace – 30 minutes <p>Increase the workout level adjustment during training weeks, if necessary, to maximize your Mobia™ fitness benefits.</p>
Week 2	<ul style="list-style-type: none"> • 3x per week, do a Mobia™ workout at stable, constant pace – 30 minutes • If this feels easier by the end of the week, continue to Week 3. If not, feel free to repeat the week. 	<ul style="list-style-type: none"> • 2 days steady pace – 30 minutes • 1 day interval training – 30 minutes <p>Increase the workout level adjustment during training weeks, if necessary, to maximize your Mobia™ fitness benefits.</p>	<p>Use Week 1 as a guide to help you start building your own long-term fitness routine, adjusting your interval speeds, resistance, step depth, etc., in order to maximize your Mobia™ benefits.</p>
Week 3	<ul style="list-style-type: none"> • 2 days steady pace – 30 minutes • 1 day interval training – 30 minutes 	<p>Use Weeks 1 and 2 as a guide to help you start building your own long-term fitness routine, adjusting your interval speeds, resistance, step depth, etc., in order to maximize your Mobia™ benefits.</p>	
Week 4	<ul style="list-style-type: none"> • 2 days interval training – 30 minutes • 1 day steady pace – 30 minutes <p>Increase the workout level adjustment during training weeks, if necessary, to maximize your Mobia™ fitness benefits.</p>		
Week 5	<p>Use Weeks 1, 2, 3 and 4 as a guide to help you start building your own long-term fitness routine, adjusting your interval speeds, resistance, step depth, etc., in order to maximize your Mobia™ benefits.</p>		

Maintenance

⚠ DANGER To reduce the risk of electrical shock, always unplug the power cord and wait 5 minutes before cleaning, maintaining or repairing this machine.

Read all maintenance instructions fully before you start any repair work. In some conditions, an assistant is necessary to do the necessary tasks.

⚠ Equipment must be regularly examined for damage and repairs. The owner is responsible to make sure that regular maintenance is done. Worn or damaged components must be replaced immediately or the equipment removed from service until the repair is made. Only manufacturer supplied components can be used to maintain and repair the equipment.

⚠ This product, its packaging, and components contain chemicals known to the State of California to cause cancer, birth defects, or reproductive harm. This Notice is provided in accordance with California's Proposition 65. If you would like additional information, please refer to our Web site at www.nautilus.com/prop65.

Daily: Before each use, inspect for loose, broken, damaged, or worn parts. Do not use the machine if any of these conditions exist. Use a dry cloth to wipe off any perspiration after each use.

Weekly: Check for smooth roller operation. Clean the machine to remove dust, dirt, or grime. Clean the top of the belt with a damp, soapy cloth and wipe carefully and thoroughly with a dry cloth. Do not let any liquid below the belts or into the Base Frame.

Monthly: Make sure all bolts and screws are tight. Tighten if necessary.

NOTICE: Do not clean with a petroleum based solvent or an automotive cleaner. Be sure to keep the Console free of moisture.

Walking Belt and Deck Lubrication

The Mobia™ fitness machine is equipped with a low maintenance deck and belt system. Belt friction can affect the function and life of the machine. For the best results lubricate the Treadles periodically with a silicone lubricant, using the following instructions:

1. Unplug the machine fully from the wall outlet, and remove the power cord from the machine.
2. Apply a very thin layer of silicone lubricant on the Treadle deck below each belt. Carefully lift each belt and apply a few drops of the lubricant the entire width of the belt.

Use the following timetable as a guide to lubricate the decks:

- Light user (fewer than 3 hours / week): every 3 months
- Moderate user (3-5 hours / week): every 2 months
- Heavy user (more than 5 hours / week): every month

NOTICE: Always use a silicone-based lubricant. Do not use a degreaser like WD-40® as this could seriously impact performance.

3. Connect the power cord back into the machine and then into the wall outlet.
4. Stay to one side of your machine.
5. Switch on your machine and start the belts at the slowest speed. Let the belts operate for approximately 15 seconds.
6. Switch off your machine.
7. Take care to clean up any excess lubricant from the Treadles. We also recommend a periodic inspection of the Treadle surfaces below the belts. If the decks appear worn, contact a Nautilus® Representative (refer to the Contacts page of this manual).



To decrease the possibility of slipping, be sure the Treadle area is free from grease or oil. Clean off any excess oil from the machine surfaces.

We recommend that you use the following:

- 8300 Silicone Spray, available at most Hardware and Auto Parts stores.
- Lube-N-Walk® Treadmill Lubrication Kit, available from your local specialty fitness dealer or Nautilus, Inc.

As you use your fitness machine, the Console will show "LUbE" at set times. This is only a reminder and should be added to your inspection schedule. Only apply lubricant as necessary.

Moving Your Machine

The Mobia™ fitness machine weighs approximately 200 lbs (90.7 kg) when fully assembled and requires caution when being moved. Use the Transport Handle found under the front of the machine to move it. To get access to the Transport Handle, turn the Levelers until you have sufficient clearance between the machine and floor.

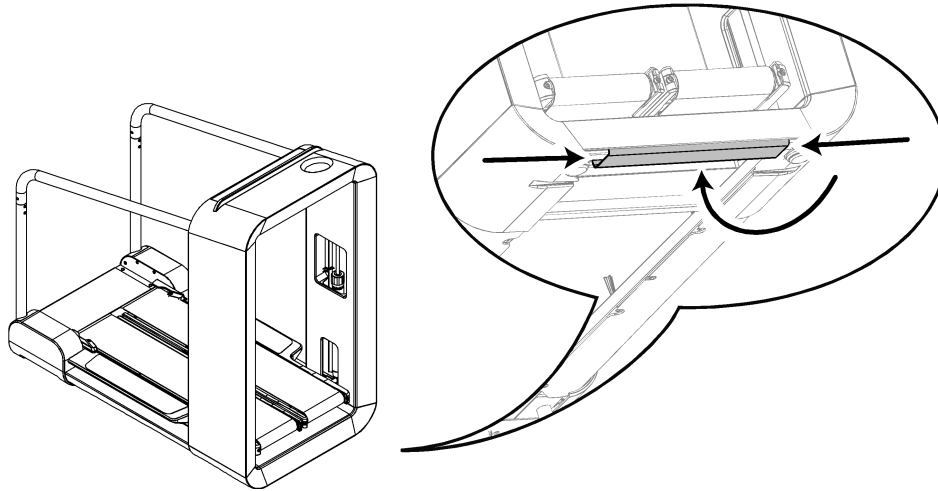

Your machine can be rolled on the transport wheels to a new location. Lower your machine slowly into its new location without injury to your head or fingers.



Do not use the uprights, arms, or the Console to lift or move the machine. Injury to you or damage to the machine can occur.

The machine can be moved by one or more persons. Make sure that your own physical strength is capable of moving the machine.

Place the machine on a clean, hard, level surface, free from unwanted material or other objects that may hamper your ability to move freely. A rubber mat should be used below the machine to prevent the release of static electricity and protect your flooring.

For safe storage of the machine and to prevent unsupervised operation of the machine always remove the Safety Key and disconnect the power cord from the wall outlet or machine AC input.

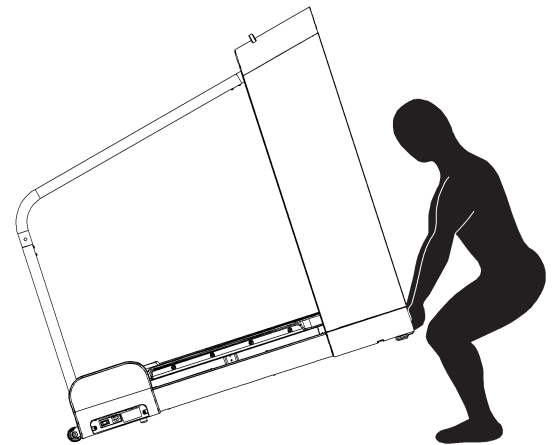

Troubleshooting

Condition/Problem	Things to Check	Solution
Unit will not power up/turn on/start	Outlet	Make sure outlet is functioning correctly. Verify this by plugging another object (ex: lamp) into the outlet. If outlet is connected to a light switch, check to make sure it is on. If outlet is not functioning find a working outlet.
	Power cord not plugged in	Make sure the power cord is firmly secured to A/C inlet on the unit and firmly inserted into a non-GFI wall socket.
	Power switch turned off	Make sure the power switch at the rear of the unit is in the "ON" position. Switch will light up red to indicate power is present.
	Safety key not plugged in	Plug Safety Key into Console (See Emergency Stop Procedure within the Important Safety Precautions section).
Speed displayed is not accurate	Display set to wrong unit of measure. (English/Metric)	Change display units.
Heart rate not displayed while using chest strap	Transmitter not making good contact with skin	Moisten skin contact area on the chest strap.
	Electromagnetic interference	Turn off any television, AM radio, microwave, or computer within 6 feet (2 meters) of the fitness machine.
	Chest strap transmitter	Test chest strap with another HR monitoring device such as HR watch or a machine at a gym. If transmitter has good skin contact and still is not found to be emitting HR signal, replace chest strap transmitter.

Condition/Problem	Things to Check	Solution
	HR receiver	If chest strap is known to work with other devices and no sources of interference are present, or console has been tested with a Pulse Simulator and is not receiving the signal, contact Customer Care for replacement HR receiver.
Walking belt misalignment	Rear belt guides	Belts should ride on top of triangular black belt guides at rear of treadles.
	Tracking adjustment	Belts are not required to be perfectly centered and are typically farther out in the rear than they are in the front. This may vary depending on user's stride. If belt is tracking to one side far enough to cause rubbing of belt, follow belt alignment procedure in Owner's Manual.
Speed dependent grinding or scraping noise	Belt alignment	Check walking belt alignment. Belt contact with metal guides under Treadle can make a loud grinding sound. If belts are misaligned, adjust walking belt.
	Rollers or motor	Contact Customer Care for further assistance.
Hesitation or belt slipping when walking on unit	Walking belt tension	Adjust walking belt tension at the front of the unit using the provided hex wrench on the exposed adjustment bolts located on each side of each front roller. Be sure to adjust both bolts on each roller the same amount as to not disrupt belt alignment. Tighten (turn clockwise) each adjustment bolt in full turn increments. After each adjustment, restart unit and check to see if belt slippage has been eliminated. Repeat if necessary. If slipping feel persists after several adjustments, stop and refer to drive belt checklist.
Knocking noises when unit is operating	Igus bushing	If knocking sound seems to be coming directly from the rear roller, check igus bushings and replace if cracked.
	Hydraulic cylinder bolts	Check and tighten both upper and lower bolts that connect the hydraulic cylinders to the unit.
"Tick" sound once per revolution or scraping noise from under Treadle	Belt alignment	Belt seam may be contacting metal belt guide under treadle. Slight adjustment of belt should alleviate noise. Follow belt alignment procedure in Owner's Manual.
Belts stop turning while in use	Safety key	Plug Safety Key into Console (See Emergency Stop Procedure within the Important Safety Instructions section).
	Motor overload	Unit may be overloaded and drawing too much current, causing unit to shut power down to protect motor. Consult belt lubrication schedule to determine if belts need lubrication, check walking belt tension, and restart unit.
Console displays "C", "S", or "H" with a number	Console	Cycle power off and on to clear the error. If issue recurs contact Customer Service for further assistance.

