

FREEMOTION[®] *incline trainer*

Model No. FMTK72509.0/
FMTK75009.0

Serial No. _____

Write the serial number in the space above for future reference.

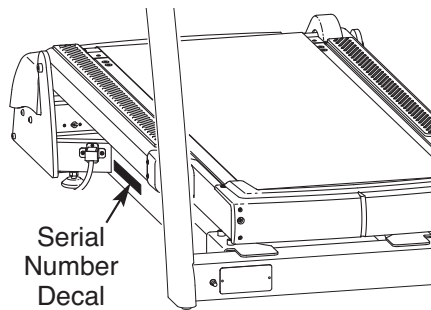

QUESTIONS?

If you have questions, or if parts are damaged or missing, please see **HOW TO CONTACT CUSTOMER CARE** on the back cover of this manual.

CAUTION

Read all precautions and instructions in this manual before using this equipment. Keep this manual for future reference.

USER'S MANUAL

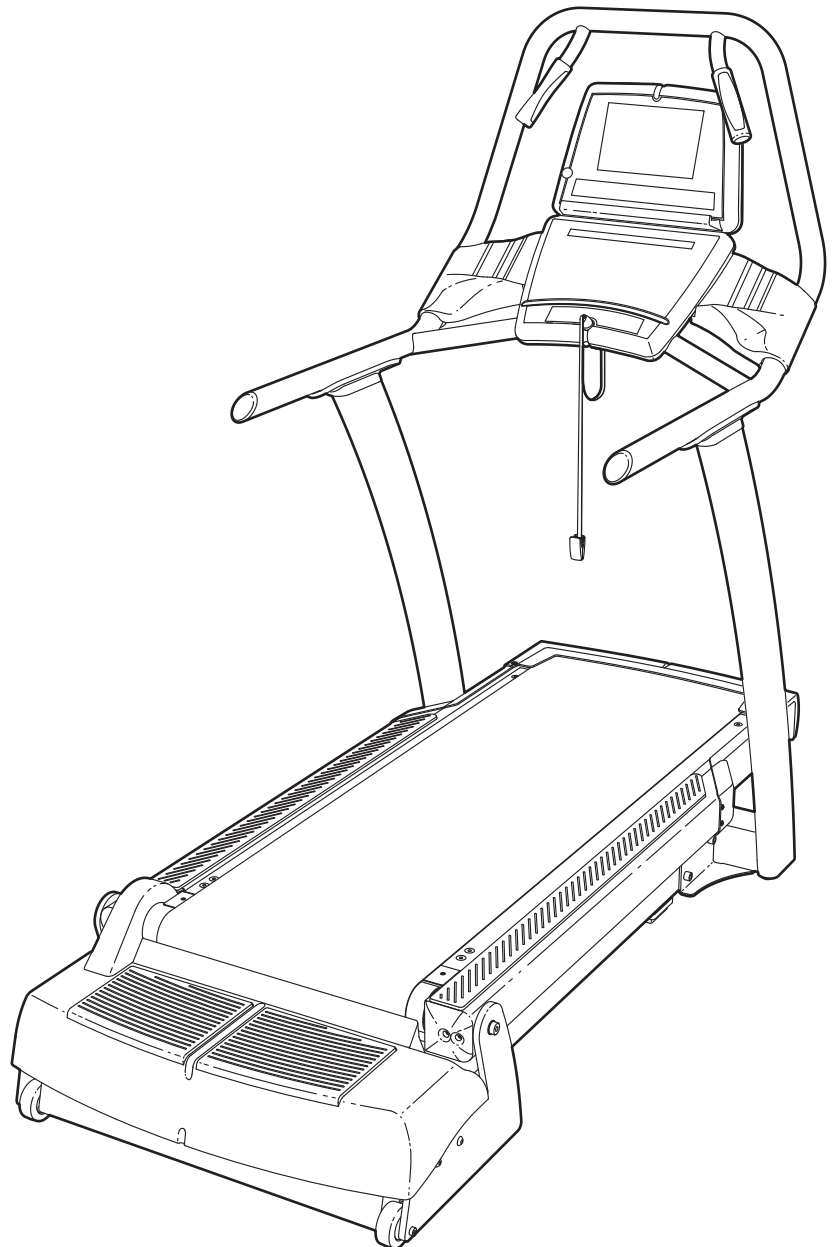

TABLE OF CONTENTS

IMPORTANT PRECAUTIONS3
WARNING DECAL PLACEMENT5
BEFORE YOU BEGIN6
ASSEMBLY7
HOW TO MOVE THE INCLINE TRAINER11
HOW TO CONNECT THE INCLINE TRAINER12
HOW TO UPGRADE THE CONSOLE13
HOW TO USE THE BASIC CONSOLE14
PREVENTIVE MAINTENANCE34
SIX-MONTH PREVENTIVE MAINTENANCE RECORD37
TROUBLESHOOTING38
EXERCISE GUIDELINES40
PART LIST42
EXPLODED DRAWING44
HOW TO CONTACT CUSTOMER CARE	Back Cover

IMPORTANT PRECAUTIONS

⚠️ WARNING: To reduce the risk of serious injury, read all important precautions and instructions in this manual and all warnings on your incline trainer before using your incline trainer. FreeMotion Fitness assumes no responsibility for personal injury or property damage sustained by or through the use of this product.

1. Before beginning any exercise program, consult your physician. This is especially important for persons over age 35 or persons with pre-existing health problems.
2. It is the responsibility of the owner to ensure that all users of the incline trainer are adequately informed of all warnings and precautions.
3. Keep the incline trainer indoors, away from moisture and dust. Do not place the incline trainer in a garage or covered patio, or near water.
4. Place the incline trainer on a level surface, with at least 2.4 m (8 ft.) of clearance behind it and 0.6 m (2 ft.) on each side. Do not place the incline trainer on a surface that blocks any air openings. To protect the floor or carpet from damage, place a mat under the incline trainer.
5. Do not operate the incline trainer where aerosol products are used or where oxygen is being administered.
6. Do not operate the incline trainer until it is properly and fully assembled (see ASSEMBLY on page 7).
7. Regularly inspect and tighten all parts of the incline trainer.
8. Keep children under age 12 and pets away from the incline trainer at all times.
9. The incline trainer should not be used by persons weighing more than 350 lbs. (159 kg).
10. Never allow more than one person on the incline trainer at a time.
11. Wear appropriate exercise clothes when using the incline trainer. Do not wear loose clothes that could become caught in the incline trainer. Athletic support clothes are recommended for both men and women. *Always wear athletic shoes. Never use the incline trainer with bare feet, wearing only stockings, or in sandals.*
12. When connecting the power cord, follow the instructions on page 12. No other appliance should be on the same circuit as the incline trainer. Do not use an extension cord.
13. Keep the power cord away from heated surfaces.
14. Never move the walking belt while the power is turned off. Do not operate the incline trainer if the power cord or plug is damaged or if the incline trainer is not working properly. (See TROUBLESHOOTING on page 38 if the incline trainer is not working properly.)
15. Read, understand, and test the emergency stop procedure before using the incline trainer (see GETTING STARTED on page 18).
16. Never start the incline trainer while you are standing on the walking belt. Always hold the handrails while using the incline trainer.
17. The incline trainer is capable of high speeds. Adjust the speed in small increments to avoid sudden jumps in speed.

18. The pulse sensor is not a medical device. Various factors, including the user's movement, may affect the accuracy of heart rate readings. The pulse sensor is intended only as an exercise aid in determining heart rate trends in general.
19. Never leave the incline trainer unattended while it is running.
20. Do not change the incline of the incline trainer by placing objects under it.
21. Never insert or drop any object into any opening on the incline trainer.
22. Make sure to perform all maintenance procedures outlined in this manual. Failure to do so will void the warranty and may result in damage to the incline trainer.
23. **DANGER:** Always unplug the power cord before cleaning the incline trainer and before performing the maintenance and adjustment procedures described in this manual. Servicing other than the procedures in this manual should be performed by an authorized service representative only.
24. Over exercising may result in serious injury or death. If you feel faint or if you experience pain while exercising, stop immediately and cool down.
25. Use the incline trainer only as described in this manual.

SAVE THESE INSTRUCTIONS

WARNING DECAL PLACEMENT

These drawings show the location(s) of the warning decal(s). If a decal is missing or illegible, see the back cover of this manual and request a free replacement decal. Apply the decal in the location shown.

Note: The decal(s) may not be shown at actual size.

⚠ CAUTION: HIGH VOLTAGE
Disconnect line cord from outlet before servicing.

⚠ CAUTION
KEEP HANDS AND FEET AWAY FROM THIS AREA WHILE THE TREADMILL IS IN OPERATION.

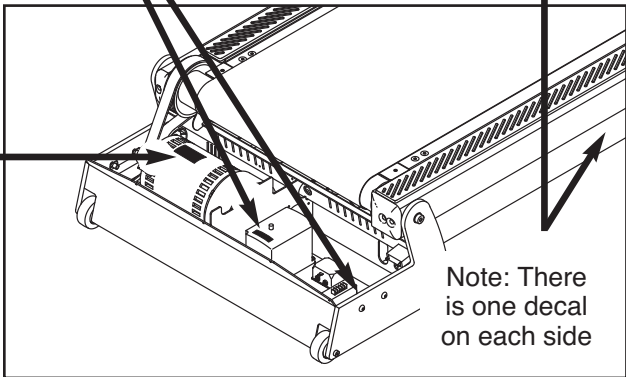

⚠ CAUTION: HIGH VOLTAGE
Disconnect line cord from outlet before servicing.

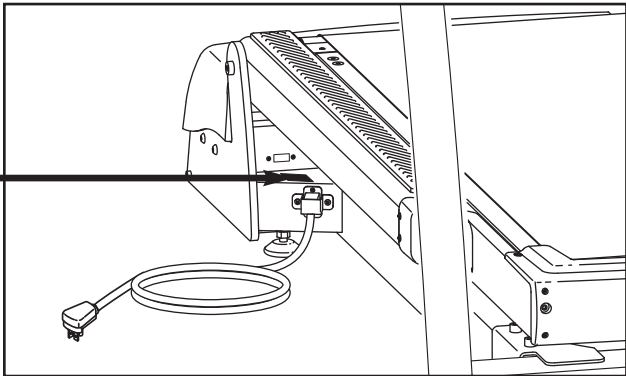

BEFORE YOU BEGIN

Thank you for selecting the revolutionary FREEMOTION® INCLINE TRAINER. The INCLINE TRAINER provides an impressive selection of features designed to make your workouts at home more effective and enjoyable.

For your benefit, read this manual carefully before you use the incline trainer. If you have questions

after reading this manual, please see the back cover of this manual. To help us assist you, note the product model number and serial number before contacting us. The model number and the location of the serial number decal are shown on the front cover of this manual.

Before reading further, please familiarize yourself with the parts that are labeled in the drawing below.

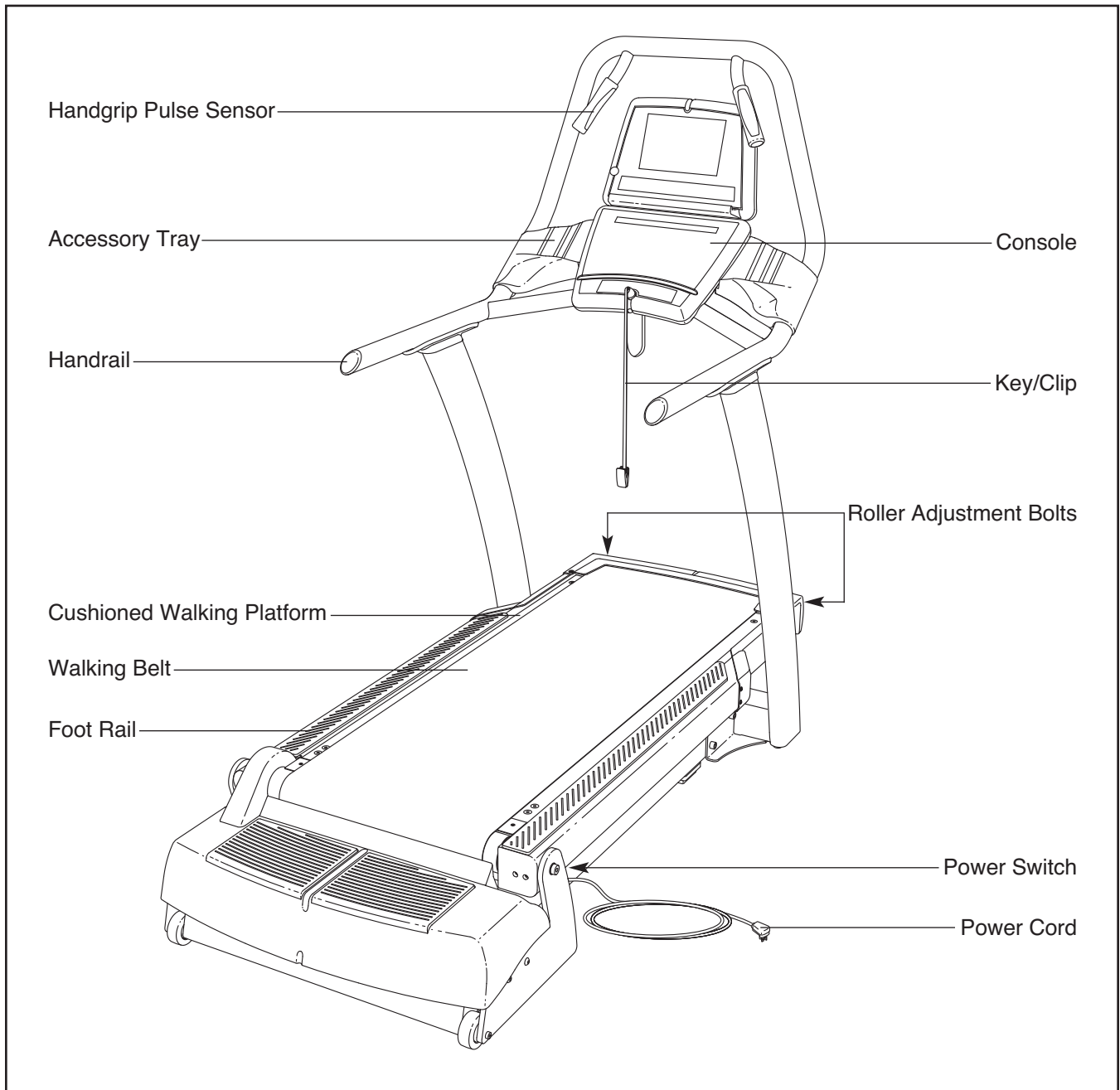

ASSEMBLY

Assembly requires two persons. Set the incline trainer in a cleared area and remove all packing materials. Do not dispose of the packing materials until assembly is completed. **Assembly can be completed using a 3/8" hex key, a 7/32" hex key, and a Phillips screwdriver.**

For help identifying assembly hardware, see the drawings below. **Note: Some small parts may have been pre-assembled. To avoid damaging parts, do not use power tools for assembly.**

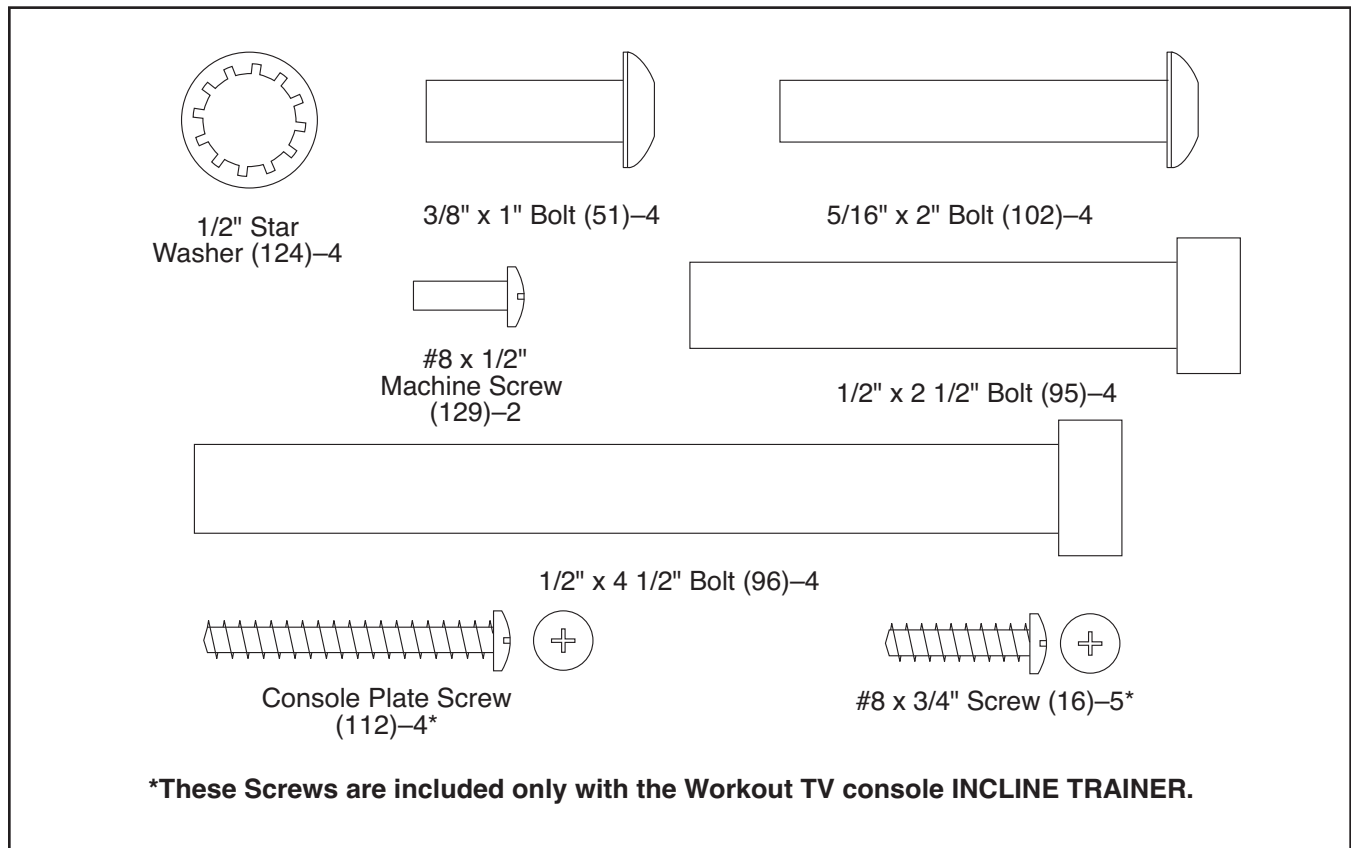

1. Place the Uprights (93) near the front of the Base Frame (56) as shown.

As you slide the Uprights (93) onto the Base Frame (56), insert the Frame Wire Harness (133) into the large hole in the Upright. **Be careful to avoid pinching the wire.**

Align the holes in the Uprights (93) with the holes in the Base Frame (56).

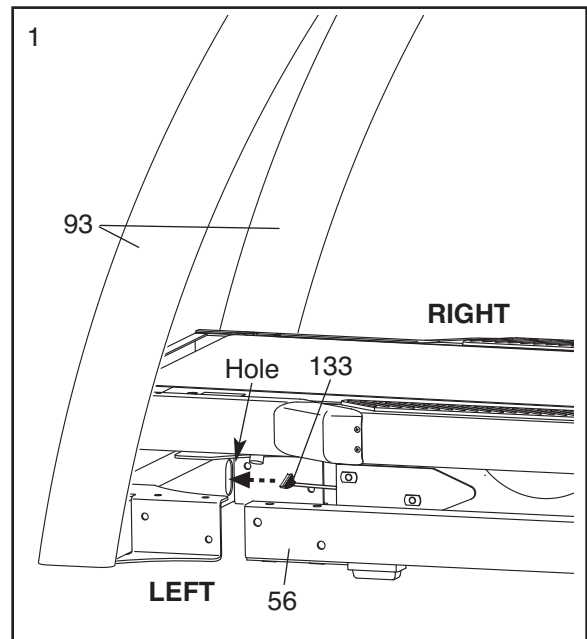

2. Locate the Frame Wire Harness (133) and Upright Wire Harness (119) in the Upright (93) access hole.

Connect the Frame Wire Harness (133) and Upright Wire Harness (119) at the front of the Uprights (93). **See the inset drawing. The connectors should slide together easily and snap into place.** If they do not, turn one connector and try again. **IF YOU DO NOT CONNECT THE CONNECTORS PROPERLY, THE CONSOLE MAY BECOME DAMAGED WHEN YOU TURN ON THE POWER.**

Attach the Access Plate (130) to the Uprights (93) with two #8 x 1/2" Machine Screws (129).

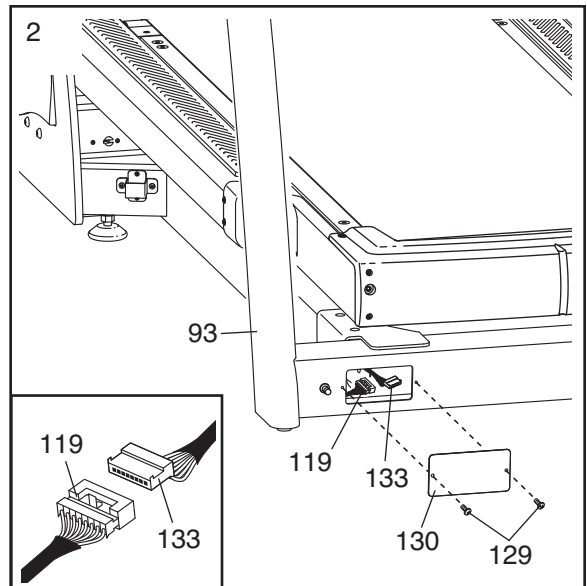

3. Partially tighten two 1/2" x 2 1/2" Bolts (95) through the bracket near the right Upright (93) and into the Base Frame (56); **do not tighten the Bolts yet. Be careful not to pinch any wires.**

Repeat this step on the left side of the incline trainer.

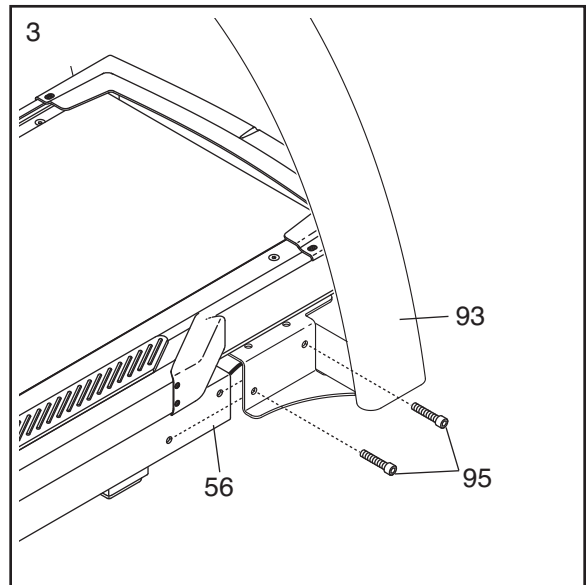

4. Partially tighten two 1/2" x 4 1/2" Bolts (96) with two 1/2" Star Washers (124) through the top of the bracket near the right Upright (93) and into the Base Frame (56); **do not tighten the Bolts yet. Be careful not to pinch any wires.**

Repeat this step on the left side of the incline trainer.

Then, tighten the 1/2" x 4 1/2" Bolts (96) and the 1/2" x 2 1/2" Bolts (95) on both sides.

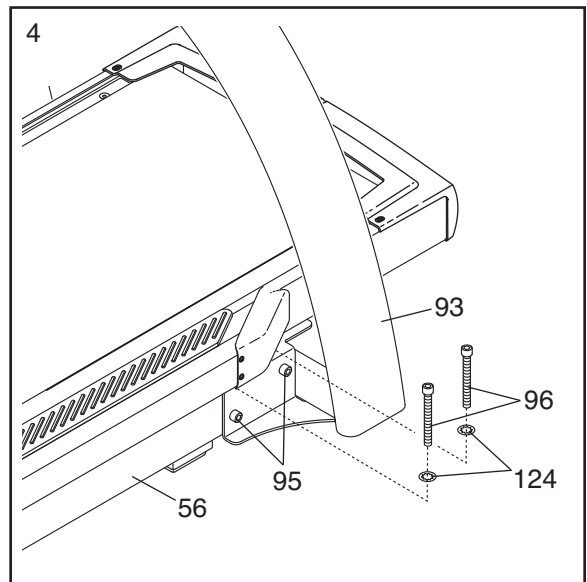

- Orient one of the Handrail Brackets (92) with the 5/16" x 1 3/4" Bolt (113) positioned as shown. Insert the Upright Wire Harness (119) and the Upright TV Cable (116) through the large hole in the Handrail Bracket.

Attach the Handrail Bracket (92) to the top of the right Upright (93) with two 5/16" x 2" Bolts (102). **Start both Bolts, and then tighten each of them. Be careful not to pinch any wires.**

Attach the other Handrail Bracket (92) to the top on the left Upright (93) as described above. Note: There are no wires on the left side.

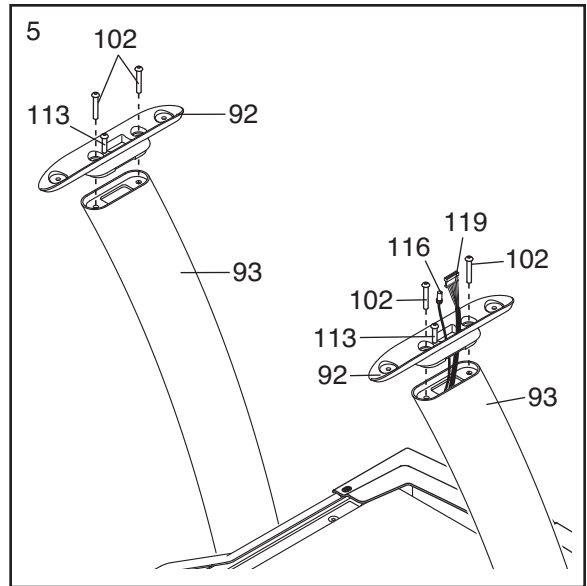

- With the help of a second person, set the handrail assembly onto the top of the Uprights (93). **Make sure that the 5/16" x 1 3/4" Bolts (113) are inserted into the indicated holes in the bottom of the handrail assembly (only one side is shown). Be careful not to pinch any wires.**

Carefully slide the console assembly forward until the 5/16" x 1 3/4" Bolts (136) slide into the indicated slot. Allow the console assembly to tilt forward so that you can see the Upright Wire Harness (119), Console Wire Harness (135), Upright TV Cable (116), and Console TV Cable (107). **Make sure the console assembly is held securely by the Bolts.**

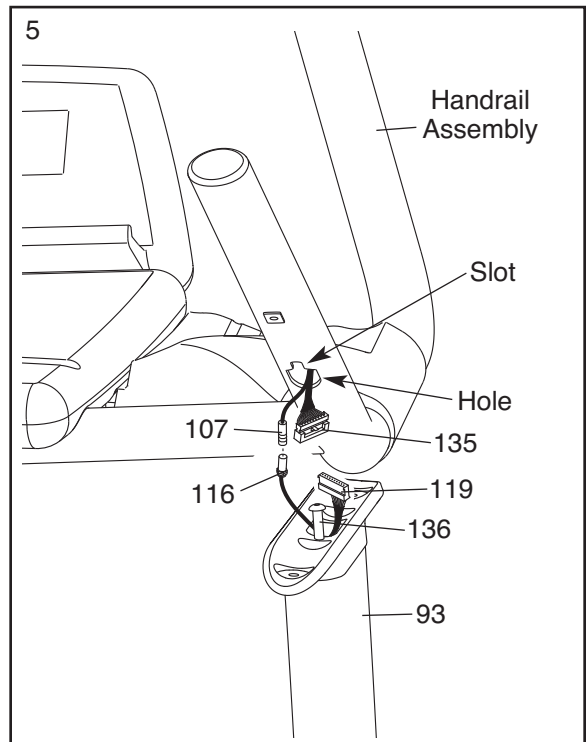

- Connect the Upright Wire Harness (119) and Console Wire Harness (135). **See the inset drawing. The connectors should slide together easily and snap into place.** If they do not, turn one connector and try again. **IF YOU DO NOT CONNECT THE CONNECTORS PROPERLY, THE CONSOLE MAY BECOME DAMAGED WHEN YOU TURN ON THE POWER.** Connect the Upright TV Cable (116) and Console TV Cable (107). Insert the wires downward into the right Upright (93).

Make sure that the handrail assembly is sitting flat on the Handrail Brackets (92). **Be careful not to pinch any wires.**

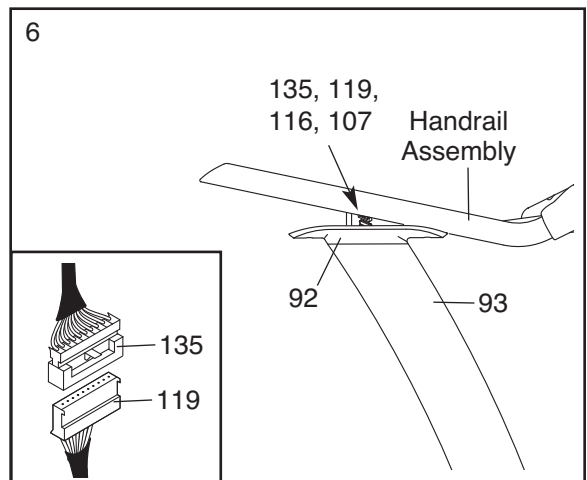

7. Attach the handrail assembly to the Handrail Brackets (92) with four 3/8" x 1" Bolts (51); **start all four Bolts, and then tighten each of them.**

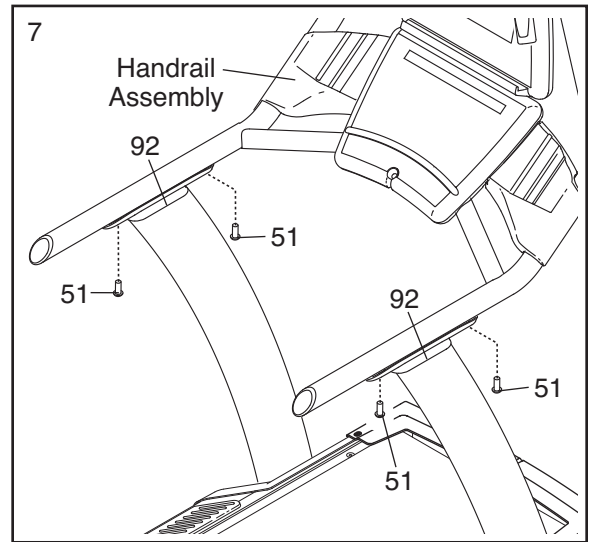

8. After the incline trainer is placed in the location where it will be used (see HOW TO MOVE THE INCLINE TRAINER on page 11), make sure that both Rear Leveling Feet (38) and the Base Pads (not shown) rest firmly on the floor. If the incline trainer rocks even slightly, turn one of the Rear Leveling Feet clockwise or counterclockwise until the rocking motion is eliminated.

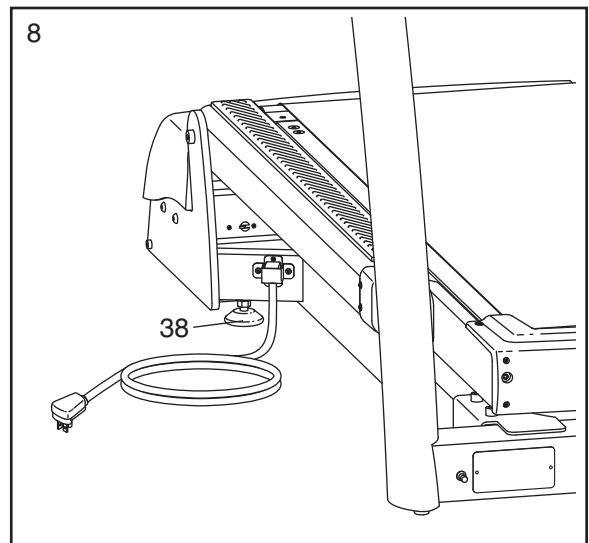

9. **Make sure that all parts are properly tightened before you use the incline trainer.** To protect the floor or carpet, place a mat beneath the incline trainer.

If you purchase the Workout TV console, follow the steps below to assemble the console.

Unplug the power cord. Remove the four Console Plate Screws (112) and the Basic Console Plate (not shown). Remove the five #8 x 3/4" Screws (A) from the back of the Basic Console (not shown), and remove the Basic Console from the incline trainer. Disconnect all wires connecting the Basic Console to the incline trainer.

Insert the wire harness, the TV cable, and the ground wire into the bottom of the TV Console (137) as you slide the TV Console onto the bracket on the Handrail (103). Connect the wire harness, the TV cable, and the ground wire to the back of the TV Console. **Make sure to connect the connectors properly.**

Align the indicated five holes in the back of the TV Console (137) with the five holes in the bracket on the Handrail (103). Attach the TV Console with five #8 x 3/4" Screws (A). **Be careful not to pinch any wires.**

Attach the TV Console Plate (118) to the TV Console (137) with four Console Plate Screws (112).

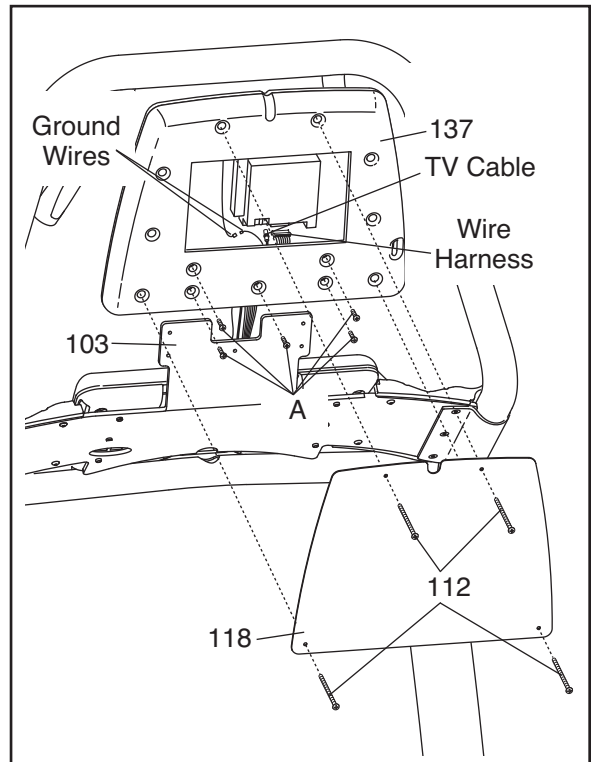

HOW TO MOVE THE INCLINE TRAINER

Before moving the incline trainer, unplug the power cord. Note: It may be necessary to disconnect a CATV cable and a network wire from the incline trainer, depending on how far the incline trainer will be moved.

Due to the size and weight of the incline trainer, moving it requires two or three persons. Hold the metal frame firmly in the location shown at the right. CAUTION: To decrease the possibility of damage to the incline trainer or of injury, do not lift the frame by the front cover. Carefully roll the incline trainer on the wheels to the desired location and then lower it back to the level position. **CAUTION: To reduce the risk of injury, use extreme caution while moving the incline trainer. Do not attempt to move the incline trainer over uneven surfaces.**

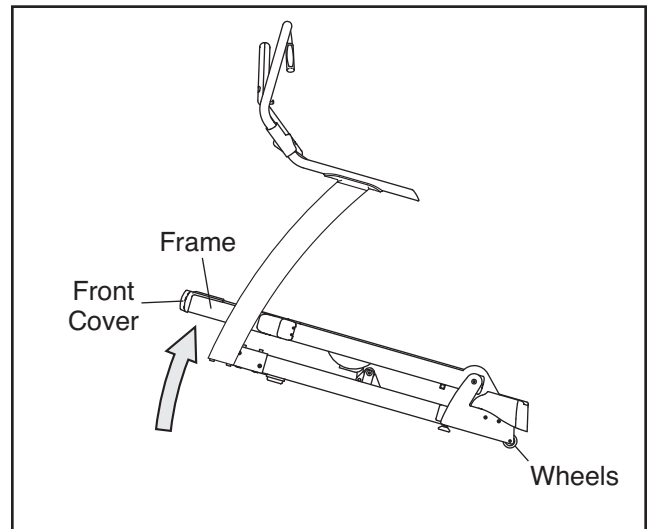

HOW TO CONNECT THE INCLINE TRAINER

⚠ DANGER: Improper connection of the equipment-grounding conductor increases the risk of electric shock. Check with a qualified electrician or serviceman if you are unsure whether the product is properly grounded. Do not modify the plug—if it will not fit the outlet, have a proper outlet installed by a qualified electrician. Do not use an adapter to connect the plug to an improper receptacle.

HOW TO CONNECT THE POWER CORD

This product must be grounded. If it should malfunction or break down, grounding provides a path of least resistance for electric current to reduce the risk of electric shock.

This product is for use on a dedicated, 20-amp, 110-volt circuit. No other appliance should be on the same circuit. This product is equipped with a cord having an equipment-grounding conductor and a grounding plug.

Plug the grounding plug into a standard NEMA 5-20 receptacle. Do not modify the plug or the receptacle. Do not use an adapter, a surge protector, or an extension cord. The receptacle must be grounded.

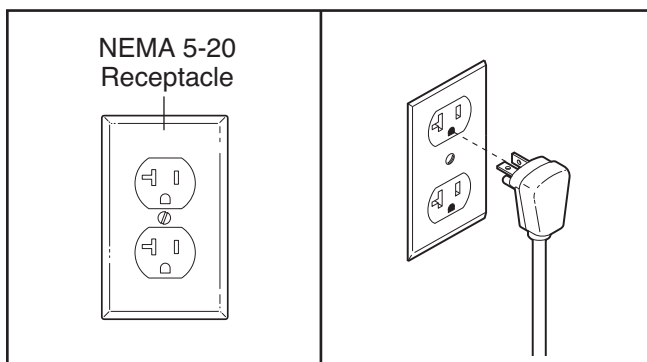

HOW TO CONNECT A CATV CABLE

If your incline trainer has the Workout TV console, a CATV cable must be connected to the incline trainer for cable TV stations to be viewed.

Locate the cable jack on the front of the incline trainer. Connect the CATV cable to the cable jack. Route the cable so that it will not be pinched or crushed by the lift mechanism or the frame.

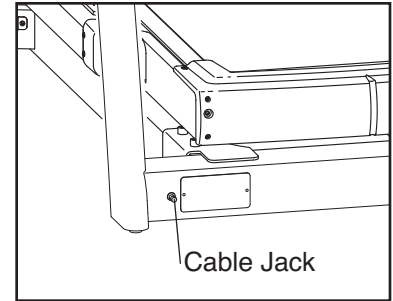

A satellite receiver, VCR, or DVD player can also be connected to the incline trainer. Connect a CATV cable from the coaxial output on your equipment (usually labeled TV OUT or RF OUT) to the cable jack on the front of the incline trainer.

Note: Audio/video equipment without coaxial outputs (some satellite receivers and DVD players) will require an RF modulator to work correctly. RF modulators are not available from FreeMotion Fitness, but are available at electronics stores. See the owner's manual for the equipment you wish to connect to determine if an RF modulator is needed, or contact your local audio/visual service provider.

WARRANTY INFORMATION

The warranty for this product does not cover damage or equipment failure caused by electric wiring not in compliance with electrical codes or the specifications in this manual, or failure to provide reasonable and necessary maintenance as outlined in this manual. Any failure or damage caused by unauthorized service; misuse; accident; negligence; improper assembly or installation; debris resulting from any destruction activities in the product's environment; rust or corrosion as a result of the product's location; alterations or modifications without written authorization; or failure on your part to use, operate, and maintain the product as set forth in this manual will void the warranty.

All terms of the warranty are void if this product is moved beyond the continental borders of the United States of America (excluding Alaska, Hawaii, and Canada) and are then subject to the terms provided by that country's local authorized FreeMotion Fitness, Inc. representative.

HOW TO UPGRADE THE CONSOLE

Your incline trainer has been pre-configured to operate with the Basic console or the Workout TV console (see the drawings below). To learn about the features of the Basic console, see page 14. To learn about the features of the Workout TV console, see the user's manual included with the Workout TV console.

To upgrade your console and expand the capabilities of the incline trainer whenever you choose, please see the back cover of this manual.

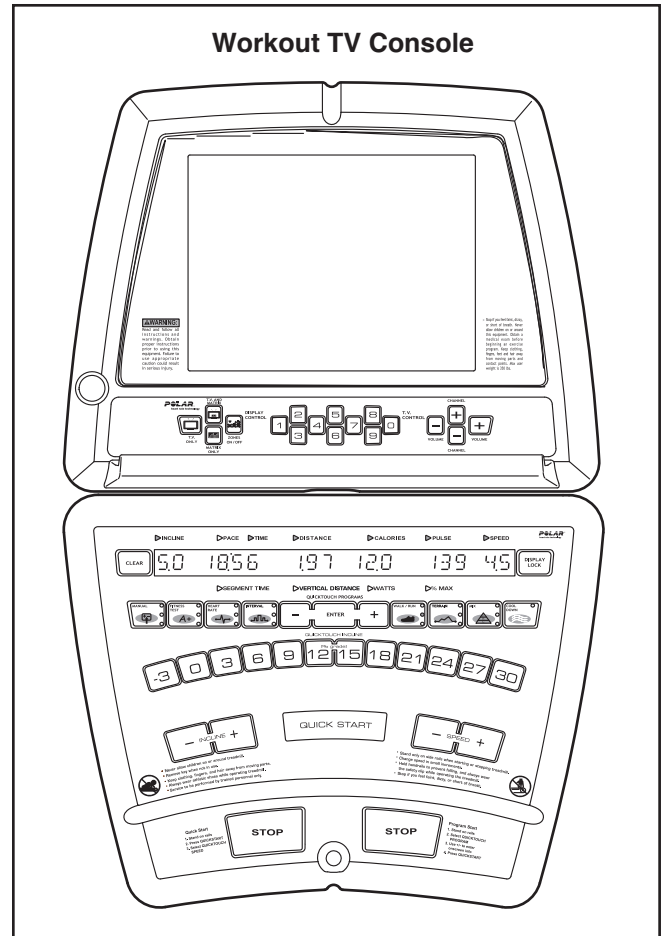
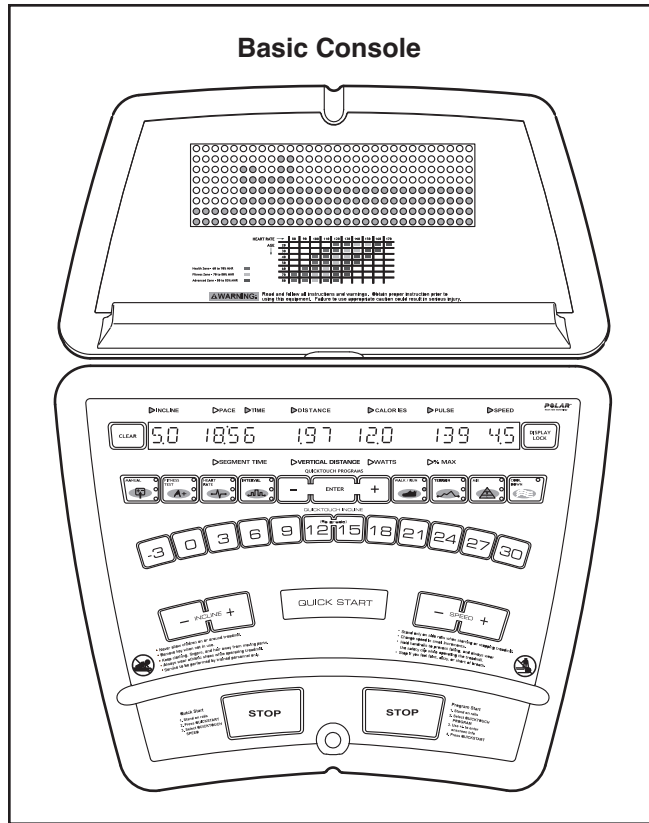

HOW TO USE THE BASIC CONSOLE

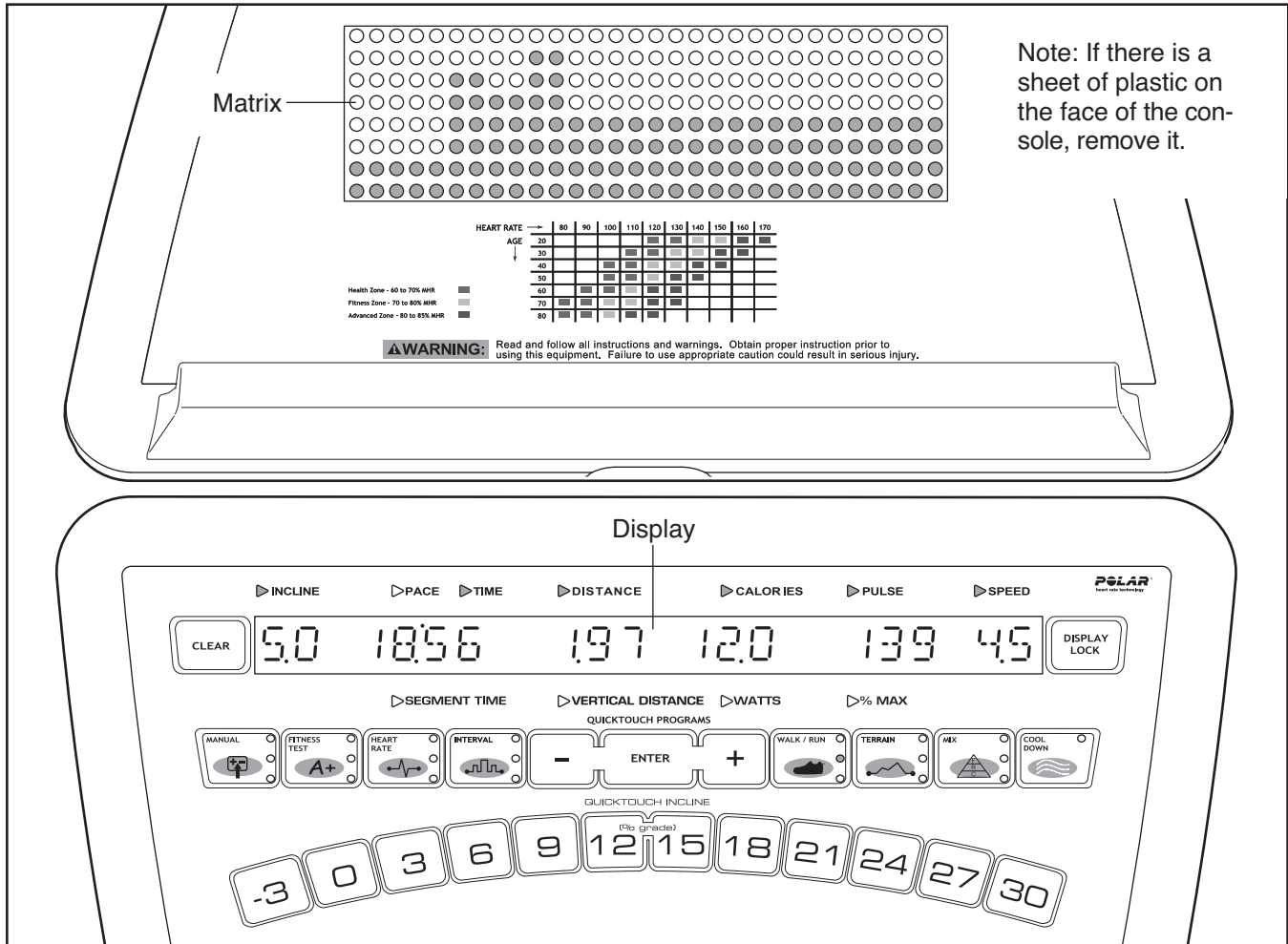

Note: If there is a sheet of plastic on the face of the console, remove it.

WARNING: Read and follow all instructions and warnings. Obtain proper instruction prior to using this equipment. Failure to use appropriate caution could result in serious injury.

FEATURES OF THE CONSOLE

The Basic console offers an impressive array of features designed to help you get the greatest benefits from your exercise.

When the QUICK START mode is selected, the speed and incline of the incline trainer can be changed with the touch of a button. As you exercise, the console will provide continuous exercise feedback. You can even measure your heart rate using the built-in pulse sensor.

In addition, the console offers a wide selection of workout programs. Each program automatically controls the speed and/or incline of the incline trainer to give you an effective workout.

The console also offers three HEART RATE programs that adjust the speed and incline of the incline trainer

to keep your heart rate near target levels during your workouts, and three unique FITNESS TEST programs that measure your relative fitness level. Note: The HEART RATE programs and the FITNESS TEST programs require the use of a Polar®-compatible chest pulse sensor (not included).

Before using the incline trainer, please read OVERVIEW OF THE CONSOLE beginning on page 15. **To use the QUICK START mode,** see page 18. **To use a MANUAL program,** see page 19. **To use a FITNESS TEST program,** see page 21. **To use a HEART RATE program,** see page 23. **To use an INTERVAL program,** see page 25. **To use a WALK/RUN program,** see page 27. **To use a TERRAIN program,** see page 28. **To use a FITNESS or RANDOM program,** see page 29. **To use a CUSTOM program,** see page 30. **To use the maintenance mode,** see page 31. **To enable or disable the safety key,** see page 33.

OVERVIEW OF THE CONSOLE

For your benefit, please read all of the instructions on pages 15 to 17 before you use the incline trainer.

THE BUTTONS

The CLEAR button—This button is used to reset the console. When this button is pressed, the display will be reset and the words SELECT PROGRAM TO BEGIN will

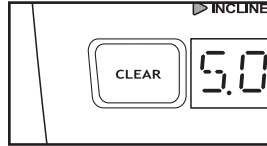

appear in the display. Note: If one program is started and then a different program is selected, the display will not be reset unless the CLEAR button is pressed before the second program is selected.

The QUICKTOUCH INCLINE buttons—These buttons control the incline of the walking belt. To change the incline quickly, press the QUICKTOUCH INCLINE buttons. Note: After the buttons are pressed, it may take a moment for the incline trainer to reach the selected incline setting.

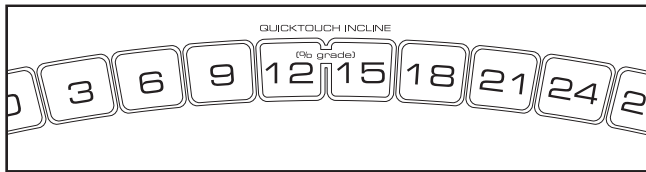

The QUICKTOUCH PROGRAMS buttons—These buttons are used to select the various programs.

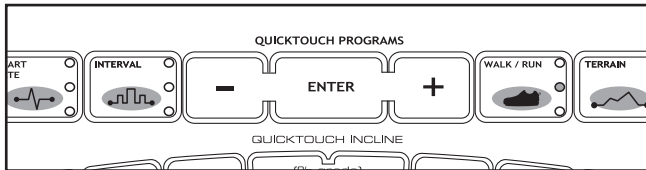

The COOL DOWN button—This button is designed to help you cool down after a workout. When you press the COOL DOWN button, the speed of the walking belt will automatically adjust to 3 mph (or 4.8 kph) and the incline will adjust to 0% for a three-minute cool-down walk. Note: If the walking belt is already moving at less than 3 mph (or 4.8 kph), the speed of the walking belt will not change.

The ENTER button and + and - buttons—These buttons are used to enter information into the console.

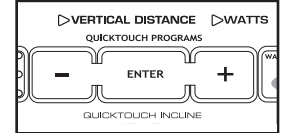

The DISPLAY LOCK button—This button can be used during your workout to keep the display from scanning from one number to the next every few seconds.

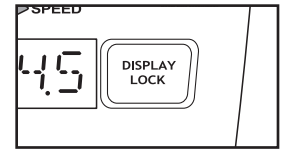

Each time the DISPLAY LOCK button is pressed during your workout, the word LOCKED or UNLOCKED will briefly appear in the display.

THE DISPLAY

The display will display a variety of text messages to guide you through your workouts. In addition, the display will display the following information while you exercise:

Incline—The left end of the display will show the incline setting of the incline trainer.

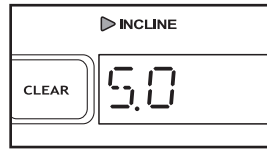

Pace/Time/Segment Time—When the QUICK START mode, the MANUAL VERTICAL DISTANCE program, the MANUAL CALORIE program, or any of the WALK/RUN programs are selected, this section of the display will show your pace, in minutes per mile or minutes per kilometer, the elapsed time, and the elapsed time in the current segment. The display will change from one number to the next every few seconds. When any other program is selected, the display will show your pace, the time remaining in the program, and the time remaining in the current segment of the program. The display will change from one number to the other every few seconds.

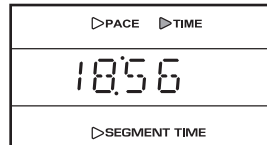

Distance/Vertical Distance—This section of the display will show the distance that you have walked or run, in miles or kilometers, and the number of vertical feet you have climbed.

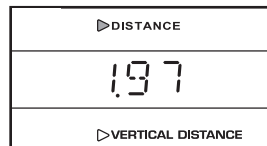

Calories/Watts—This section of the display will show the approximate number of calories you have burned and your power output in watts. The display will change from one number to the other every few seconds.



Pulse/% Max—When you use the handgrip pulse sensor or a Polar®-compatible chest pulse sensor (not included), this section of the display will show your heart rate. When a HEART RATE program is selected, the display will show your heart rate and the corresponding *percentage of your age-predicted maximum heart rate* (see step 7 on page 24 for an explanation of your age-predicted maximum heart rate). The display will change from one number to the other every few seconds. Note: The display will only show the percentage of your age-predicted maximum heart rate if you have entered your age.

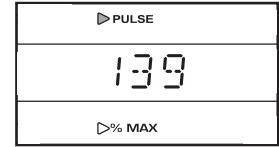

Speed—The right end of the display will show the speed of the walking belt, in miles per hour or kilometers per hour.



THE PULSE SENSOR

If there are sheets of plastic on the metal contacts on the pulse sensor, peel off the plastic. To measure your heart rate, stand on the foot rails and hold the contacts with both hands; your palms must be resting on the upper contacts, and your fingers must be touching the lower contacts. **Avoid moving your hands.** When your pulse is detected, the PULSE indicator above the display will begin to flash, and then your heart rate will be shown. For the most accurate heart rate reading, hold the contacts for at least 15 seconds without moving your hands.

If your heart rate is not shown, make sure that your hands are positioned as described. Be careful not to move your hands excessively or to squeeze the contacts too tightly. For optimal performance, clean the contacts using a soft cloth; never use alcohol, abrasives, or chemicals.

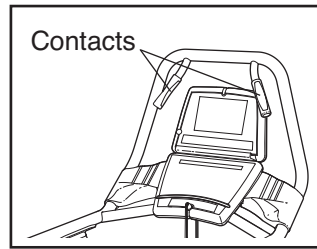

⚠ CAUTION: Before operating the console, read the following precautions.

- Do not stand on the walking belt when turning on the power.
- Always wear the clip (see the drawing on page 18) while operating the incline trainer.
- Adjust the speed in small increments to avoid sudden jumps in speed.
- The pulse sensor is not a medical device. Various factors may affect the accuracy of heart rate readings. The pulse sensor is intended only as an exercise aid in determining heart rate trends in general.
- If you have heart problems, or if you are over 60 years of age and have been inactive, do not use the HEART RATE or FITNESS TEST programs. If you are taking medication regularly, consult your physician to find whether the medication will affect your exercise heart rate.
- To reduce the possibility of electric shock, keep the console dry. Avoid spilling liquids on the console and place only a sealed water bottle in the water bottle holder.

GETTING STARTED

1. Plug in the power cord.

See HOW TO CONNECT THE POWER CORD on page 12.

2. Move the power switch to the on position.

Locate the power switch on the incline trainer near the power cord. Press the power switch into the on position.

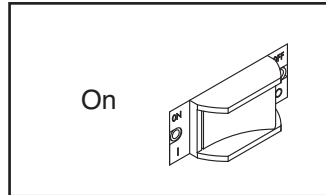

3. Insert the key into the console.

Note: The console can be set to be used without the key. See page 33 for instructions. If the console has been set to be used without the key, this step does not apply.

Find the key and the clip on the console and attach the clip to the waistband of your clothes. Next, insert the key into the console. **IMPORTANT: In an emergency, the key can be pulled from the console, causing the walking belt to slow to a stop. Test the clip by carefully taking a few steps backward; if the key is not pulled from the console, adjust the position of the clip.**

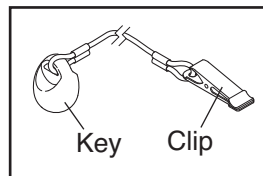

Insert the key into the console again. After a moment, various displays and indicators on the console will light.

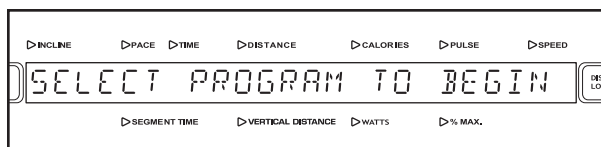

HOW TO USE THE QUICK START MODE

If you do not plan to use a program, the QUICK START mode will allow you to simply start exercising and adjust the speed and incline of the incline trainer manually.

1. Insert the key into the console.

See GETTING STARTED at the left.

2. Select the QUICK START mode.

To select the QUICK START mode, press the QUICK START button.

A moment after the button is pressed, the walking belt will begin to move at 1 mph. Hold the handrails and begin walking.

3. Change the speed and incline as desired.

As you exercise, change the speed of the walking belt as desired by pressing the SPEED + and – buttons. Each time a button is pressed, the speed setting will change by 0.1 mph; if a button is held down, the speed setting will change in rapid increments. Note: After the buttons are pressed, it may take a moment for the incline trainer to reach the selected speed setting.

To change the incline of the incline trainer, press the INCLINE + and – buttons. Each time a button is pressed, the incline will change by 0.5%. Note: After the buttons are pressed, it may take a moment for the incline trainer to reach the selected incline setting.

To change the incline quickly, press the QUICK-TOUCH INCLINE buttons. Note: After the buttons are pressed, it may take a moment for the incline trainer to reach the selected incline setting.

4. Follow your progress with the display.

The matrix will show your progress and the incline settings that you select. When you begin exercising, the left column of the matrix will begin to flash. After 30 seconds, a tone will sound and the column to the right will begin to flash.

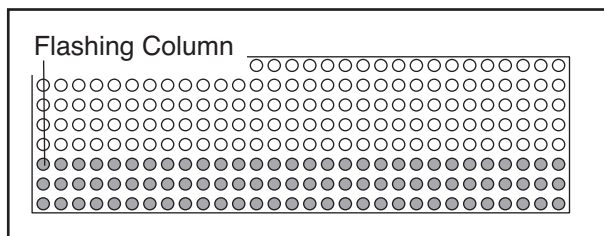

Each time you change the incline of the walking belt, additional indicators will light or darken in the flashing column, and in all columns to the right of the flashing column.

After every 30 seconds that you exercise, a tone will sound and the next column to the right will begin to flash. When you have exercised for 7 1/2 minutes, the same column will continue to flash, and *all columns of indicators will shift one position to the left*. The columns of indicators will continue to shift to the left after every 30 seconds, until you are finished exercising.

See THE DISPLAY on page 16.

5. Measure your heart rate if desired.

See THE PULSE SENSOR on page 17.

6. When you are finished exercising, stop the walking belt and remove the key.

Step onto the foot rails and press the STOP button. Next, remove the key from the console and put the key in a secure place.

When the incline trainer is not in use, switch the power switch near the power cord to the off position and unplug the power cord.

HOW TO USE A MANUAL PROGRAM

The MANUAL TIME program allows you to enter a time goal for your workout. The program will then count down the time remaining in your workout as you control the speed and incline of the incline trainer.

The MANUAL VERTICAL DISTANCE program allows you to enter a vertical distance goal for your workout. The program will calculate the vertical distance you have walked or run in your workout as you control the speed and incline of the incline trainer.

The MANUAL CALORIE program allows you to enter a calorie-burning goal for your workout. The program calculates the calories you have burned in your workout as you control the speed and incline of the incline trainer.

1. Insert the key into the console.

See GETTING STARTED on page 18.

2. Select a MANUAL program.

Press the MANUAL button one, two, or three times to select the MANUAL TIME, MANUAL VERTICAL DISTANCE, or MANUAL CALORIE program. The name of the program will appear in the display. The words ENTER AGE and the current age setting will then be shown.

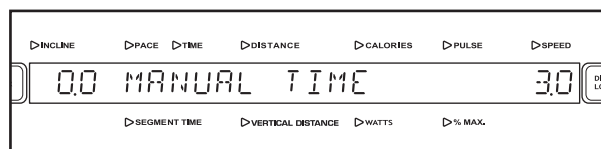

3. Enter your age.

A moment after the program is selected, the words ENTER AGE and an age setting of 35 will appear in the display. To enter your age, press the + and - buttons beside the ENTER button; hold down the buttons to enter your age quickly. When your age is shown, press the ENTER button.

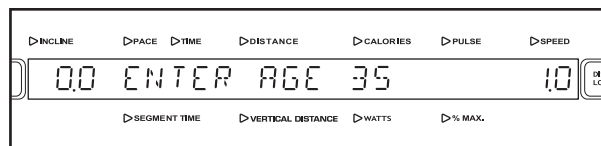

4. Enter your weight.

Next, the words ENTER WEIGHT and a weight setting of 185 pounds will appear in the display. To enter your weight, press the + and – buttons beside the ENTER button; hold down the buttons to enter your weight quickly. When your weight is shown, press the ENTER button.

5. Enter a program goal.

If you have selected the MANUAL TIME program, the words ENTER TIME and a time setting of 15 minutes will appear in the display. To change the length of time that the program will last, press the + and – buttons beside the ENTER button. Then, press the ENTER button.

If you have selected the MANUAL VERTICAL DISTANCE program, the words ENTER VERTICAL DISTANCE and a vertical distance setting of 500 feet will appear in the display. To change the vertical feet you want to walk or run during your workout, press the + and – buttons beside the ENTER button. Then, press the ENTER button.

If you have selected the MANUAL CALORIE program, the words ENTER CALORIES and a calorie-burning goal setting of 100 calories will appear in the display. To change the approximate number of calories that you want to burn during your workout, press the + and – buttons beside the ENTER button. Then, press the ENTER button.

6. Press the QUICK START button to start the program.

A moment after the button is pressed, the walking belt will begin to move at 1 mph. Hold the handrails and begin walking.

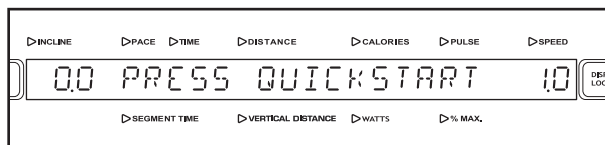

As you exercise, change the speed of the walking belt as desired by pressing the SPEED + and – buttons. Each time a button is pressed, the speed setting will change by 0.1 mph; if a button is held down, the speed setting will change in rapid increments. Note: After the buttons are pressed, it may take a moment for the incline trainer to reach the selected speed setting.

To stop the walking belt, press the STOP button. The time will begin to flash in the display. To restart the walking belt, press the QUICK START button or the SPEED + button and then adjust the speed as desired.

7. Change the incline of the incline trainer as desired.

To change the incline of the incline trainer, press the INCLINE + and – buttons. Each time a button is pressed, the incline will change by 0.5%. To change the incline quickly, press the QUICK-TOUCH INCLINE buttons. Note: After the buttons are pressed, it may take a moment for the incline trainer to reach the selected incline setting.

8. Follow your progress with the display.

See step 4 on page 19.

9. Measure your heart rate if desired.

See THE PULSE SENSOR on page 17.

10. When the program is completed, remove the key.

Step onto the foot rails. Remove the key from the console and put the key in a secure place.

When the incline trainer is not in use, switch the power switch near the power cord to the off position and unplug the power cord.

HOW TO USE A FITNESS TEST PROGRAM

The FITNESS TEST programs measure your approximate VO₂ max, or aerobic capacity. VO₂ max is a measure of your ability to take in and utilize oxygen to generate energy for endurance activities such as running and cycling. In technical terms, VO₂ max is the maximum volume of oxygen, in milliliters, that your body can use in one minute, per kilogram of body weight. A high VO₂ max indicates a high level of cardiorespiratory fitness. Note: To learn more about VO₂ max, refer to a reputable book or consult your physician.

For the most accurate results, use a FITNESS TEST program when you are not feeling tired, when you have not eaten for at least two hours, and when you have not exercised for at least 24 hours.

The GERKIN FITNESS TEST is completed when your heart rate stays greater than 85% of your age-predicted maximum heart rate for 15 seconds, or when the program reaches 11 minutes. Note: The GERKIN FITNESS TEST begins with a 3-minute warm-up.

The EBBELING FITNESS TEST is completed in 9 minutes.

The FREEMOTION FITNESS TEST is completed when your heart rate reaches greater than 70% of your age-predicted maximum heart rate, or when the program reaches 30 minutes.

Follow the steps below to use a FITNESS TEST program.

1. Put on a Polar®-compatible chest pulse sensor (not included).

You must wear a chest pulse sensor to use a FITNESS TEST program.

2. Insert the key into the console.

See GETTING STARTED on page 18.

3. Select a FITNESS TEST program.

Press the FITNESS TEST button one, two, or three times to select the GERKIN FIT TEST, the EBBELING FIT TEST, or the FREEMOTION FIT TEST.

When a FITNESS TEST program is selected, the name of the FITNESS TEST will appear in the display. The words ENTER AGE and the current age setting will then be shown.

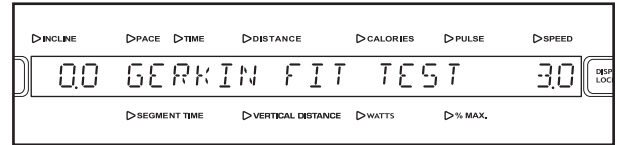

During a FITNESS TEST program, the matrix will show a moving graphic that represents your heart rate. Each time a heartbeat is detected, an additional peak will appear in the graphic.

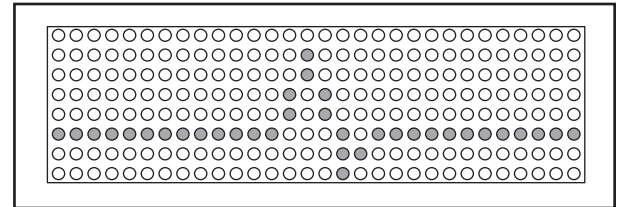

4. Enter your age.

See step 3 on page 19.

5. Enter your weight.

See step 4 on page 20.

If you have selected the EBBELING FITNESS TEST, continue to step 6. If you have selected the GERKIN FITNESS TEST or the FREEMOTION FITNESS TEST, skip to step 7.

6. Enter your gender.

If you selected the EBBELING FITNESS TEST, you will be prompted to enter your gender. Either the word MALE or the word FEMALE will appear in the display. To enter your gender, press the + and – buttons beside the ENTER button. When your gender is shown, press the ENTER button.

7. Press the QUICK START button to start the program.

A moment after the button is pressed, the incline trainer will automatically adjust to the first speed and incline settings for the program. Hold the handrails and begin walking.

Each FITNESS TEST is divided into several segments of different lengths. One speed setting and one incline setting are programmed for each segment. The console will guide you through the FITNESS TEST and record your heart rate input to determine your relative fitness level.

When the GERKIN FITNESS TEST is completed, the walking belt will slow to a stop and your VO₂ max and your fitness level will be shown in the display. Note: There are 11.4 fitness levels; fitness level 11.4 is the highest.

When the EBBELING FITNESS TEST is completed, the walking belt will slow to a stop and your VO₂ max will be shown in the display.

When the FREEMOTION FITNESS TEST is completed, the walking belt will slow to a stop and your VO₂ max and your fitness level will be shown in the display. Note: There are ten fitness levels; fitness level 10 is the highest.

Note: The SPEED and INCLINE buttons will not function while a FITNESS TEST program is selected. If your pulse is not detected during the program, the letters PLS will flash in the display. If this occurs, try the program again on another day. Make sure that you are wearing a chest pulse sensor as described in step 1 on page 21.

The FITNESS TEST programs cannot be stopped temporarily and then restarted. However, the programs can be stopped at any time with the STOP button. The display will then show the words FIT TEST ABORTED.

8. When the program is completed, remove the key.

See step 10 on page 20.

HOW TO USE A HEART RATE PROGRAM

HEART RATE programs automatically control the speed and incline of the incline trainer to keep your heart rate near a target level while you exercise. Follow the steps below to use a HEART RATE program.

1. **Put on a Polar®-compatible chest pulse sensor (not included).**

You must wear a chest pulse sensor to use a HEART RATE program.

2. **Insert the key into the console.**

See GETTING STARTED on page 18.

3. **Select a HEART RATE program.**

Press the HEART RATE button one, two, or three times to select the CONSTANT HEART RATE, VARIABLE HEART RATE, or FAT BURN program. Note: The CONSTANT HEART RATE program will keep your heart rate near a percentage that you select. The VARIABLE HEART RATE program will keep your heart rate within a target range during your workout. The FAT BURN program will keep your heart rate near 65% of your *age-predicted maximum heart rate* (see step 7 at the right for an explanation of your age-predicted maximum heart rate).



When a HEART RATE program is selected, the name of the program will appear in the display. The words ENTER AGE and the current age setting will then be shown.

During HEART RATE programs, the matrix will show a moving graphic that represents your heart rate. Each time a heartbeat is detected, an additional peak will appear in the graphic.

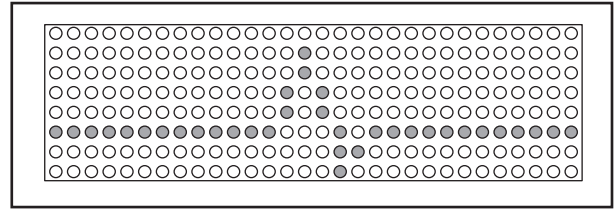

4. **Enter your age.**

See step 3 on page 19.

5. **Enter your weight.**

See step 4 on page 20.

If you have selected the VARIABLE HEART RATE program, continue to step 6. If you have selected the CONSTANT HEART RATE program, skip to step 7. If you have selected the FAT BURN program, skip to step 8.

6. **Enter a minimum target heart rate setting.**

The words MIN PERCENT and the minimum target heart rate setting for the program will be shown in the display. If desired, you can change the minimum target heart rate setting by pressing the + and – buttons beside the ENTER button. The buttons can be held down to change the minimum heart rate setting quickly. Then, press the ENTER button.

7. Enter a target heart rate setting.

The words MAX PERCENT and the target heart rate setting for the program will be shown in the display. The target heart rate setting represents a *percentage of your age-predicted maximum heart rate*. Your age-predicted maximum heart rate is 220 minus your age. For example, if you are 30 years old, your age-predicted maximum heart rate is 190 beats per minute ($220 - 30 = 190$). If you are 30 years old, a target heart rate setting of 50 is equal to 95 beats per minute (50% of 190 is 95).

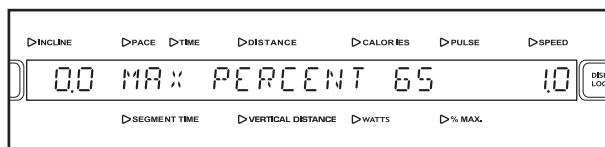

If desired, you can change the target heart rate setting by pressing the + and – buttons beside the ENTER button. The buttons can be held down to change the target heart rate setting quickly. The target heart rate setting can be from 45% to 85% of your age-predicted maximum heart rate. Then, press the ENTER button.

8. Enter a program time.

The words ENTER TIME and a time setting of 15 minutes will appear in the display. To change the length of time that the program will last, press the + and – buttons beside the ENTER button. Then, press the ENTER button.

9. Press the QUICK START button to start the program.

A moment after the button is pressed, the incline trainer will automatically adjust to the first speed and incline settings for the program. Hold the handrails and begin walking.

Each HEART RATE program is divided into 30-second segments. (The display will show both the time remaining in the program and the time remaining in the current segment of the program.) One target heart rate setting is programmed for each segment. (During the CONSTANT HEART RATE program, the same target heart rate setting will be programmed for all segments.)

When only four seconds remain in the first segment of the program, a series of tones will sound and then the speed and/or incline of the incline trainer will change, if needed, to bring your heart rate closer to the target heart rate setting for the next segment. The speed and/or incline setting will flash in the display to alert you before the speed and/or incline changes. The program will continue until no time remains in the program. The walking belt will then slow to a stop.

Note: The SPEED and INCLINE buttons will not function while a HEART RATE program is selected. If your pulse is not detected during the program, the letters PLS will flash in the display and the speed and incline of the incline trainer may automatically decrease until your pulse is detected. If this occurs, see the instructions included with your chest pulse sensor.

To stop the program at any time, press the STOP button. HEART RATE programs should not be stopped temporarily and then restarted. To use a HEART RATE program again, reselect the program and start it at the beginning.

10. Follow your progress with the display.

See THE DISPLAY on page 16.

11. When the program is completed, remove the key.

See step 10 on page 20.

HOW TO USE AN INTERVAL PROGRAM

The INTERVAL programs will automatically adjust the incline of the walking belt as they guide you through an effective interval training workout.

1. Insert the key into the console.

See GETTING STARTED on page 18.

2. Select an INTERVAL program.

Press the INTERVAL button one, two, or three times to select the INTERVAL 1 TO 1, INTERVAL 1 TO 2, or INTERVAL 1 TO 3 program. When an INTERVAL program is selected, the name of the program will appear in the display. The words ENTER AGE and the current age setting will then be shown.

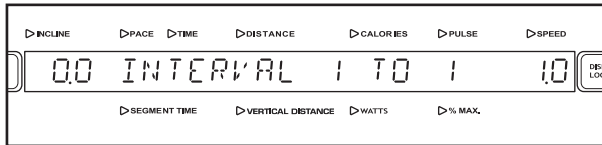

When an INTERVAL program is selected, the matrix will show a graph representing the incline settings for the program.

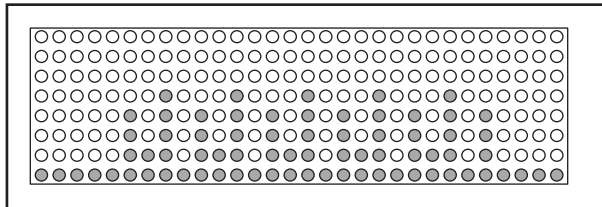

3. Enter your age.

See step 3 on page 19.

4. Enter your weight.

See step 4 on page 20.

5. Enter a program time.

See step 8 on page 24.

6. Enter a minimum incline setting.

The words MIN INCLINE and the minimum incline setting will appear in the display. To enter the minimum incline you want to walk or run during your workout, press the + and – buttons beside the ENTER button; hold down the buttons to enter the minimum incline quickly. Then press the ENTER button.

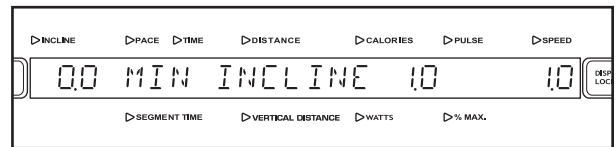

7. Enter a maximum incline setting.

The words MAX INCLINE and the maximum incline setting will appear in the display. To enter the maximum incline you want to walk or run during your workout, press the + and – buttons beside the ENTER button; hold down the buttons to enter the maximum incline quickly. Then press the ENTER button.

8. Press the QUICK START button to start the program.

A moment after the button is pressed, the walking belt will begin to move at 3 mph and the incline trainer will automatically adjust to the first incline setting for the program. Hold the handrails and begin walking.

Each program is divided into several time segments of different lengths. The display will show both the time remaining in the program and the time remaining in the current segment of the program. One incline setting is programmed for each segment. The incline setting for the first segment is shown in the flashing left column of the matrix. The incline settings for upcoming segments are shown in the columns to the right.

After every 30 seconds that you exercise, a tone will sound and the next column to the right will begin to flash.

Note: If the length of the program exceeds the number of columns in the matrix, the same column will continue to flash, and *all columns of indicators will shift one position to the left* once you have exercised for 7 1/2 minutes. The columns of indicators will continue to shift to the left after every 30 seconds, until you are finished exercising.

Note: You can manually override the incline setting for the current segment by pressing the INCLINE buttons. Every few times an INCLINE button is pressed, an additional indicator will light or darken in the flashing column. (If any of the columns to the right of the flashing column have the same number of lit indicators as the flashing column, an additional indicator may light or darken in those columns as well.) **IMPORTANT: When the next**

segment of the program begins, the incline trainer will automatically adjust to the incline setting for the next segment.

To stop the program, press the STOP button. The time will begin to flash in the display. To restart the program, press the QUICK START button.

9. Change the speed of the walking belt as desired.

To change the speed of the walking belt, press the SPEED + and – buttons. Each time a button is pressed, the speed will change by 0.1 mph. Note: After the buttons are pressed, it may take a moment for the walking belt to reach the selected speed setting.

10. Follow your progress with the display.

See THE DISPLAY on page 16.

11. Measure your heart rate if desired.

See THE PULSE SENSOR on page 17.

12. When the program is completed, remove the key.

See step 10 on page 20.

HOW TO USE A WALK/RUN PROGRAM

The 5K program is designed to help you train for a 5K race.

The 10K program is designed to help you train for a 10K race.

The CROSS COUNTRY program is designed to help you train for a race of a length of your choice.

1. Insert the key into the console.

See GETTING STARTED on page 18.

2. Select a WALK/RUN program.

Press the WALK/RUN button one, two, or three times to select the 5K, 10K, or CROSS COUNTRY program. When a WALK/RUN program is selected, the name of the program will appear in the display. The words ENTER AGE and the current age setting will then be shown.

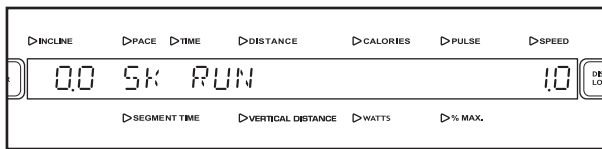

When a WALK/RUN program is selected, the matrix will show a graph representing the speed settings for the program.

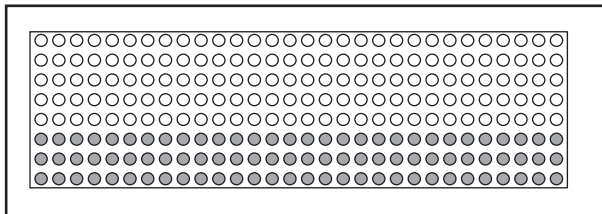

3. Enter your age.

See step 3 on page 19.

4. Enter your weight.

See step 4 on page 20.

If you have selected the 5K or 10K program, skip to step 6. If you have selected the CROSS COUNTRY program, continue to step 5.

5. Enter a distance goal.

If you have selected the CROSS COUNTRY program, the words ENTER DISTANCE and a distance setting of 10 miles will appear in the display. To change the distance you want to walk or run during your workout, press the + and – buttons beside the ENTER button. Then, press the ENTER button.

6. Enter a program time.

See step 8 on page 24. Note: The speed of your workout depends on the program time that you enter.

7. Press the QUICK START button to start the program.

A moment after the button is pressed, the walking belt will begin to move at the calculated start speed. Hold the handrails and begin walking.

If the speed of the walking belt is too fast or too slow, you can change it by pressing the SPEED + and – buttons. Note: This will change the length of time of your program.

8. Change the incline of the incline trainer as desired.

See step 7 on page 20.

9. Complete the program.

See steps 10 to 12 on page 26.

HOW TO USE A TERRAIN PROGRAM

During the HILL program, the incline of the incline trainer will depend on the vertical distance goal and the speed setting that you set. The incline will remain constant with only minor adjustments throughout the program to help you reach your vertical distance goal.

During the PEAKS program, the incline will increase and decrease. The number of times that the incline will increase and decrease will depend on the maximum incline setting and the program length that you select.

During the ALL-TERRAIN program, the incline will sharply increase and then sharply decrease repeatedly. The number of times that the incline will increase and decrease will depend on the maximum incline setting and the program length that you select.

1. Insert the key into the console.

See GETTING STARTED on page 18.

2. Select a TERRAIN program.

Press the TERRAIN button one, two, or three times to select the HILL, PEAKS, or ALL-TERRAIN program. When a TERRAIN program is selected, the name of the program will appear in the display. The words ENTER AGE and the current age setting will then be shown. When a TERRAIN program is selected, the matrix will show a graph representing the incline settings for the program.

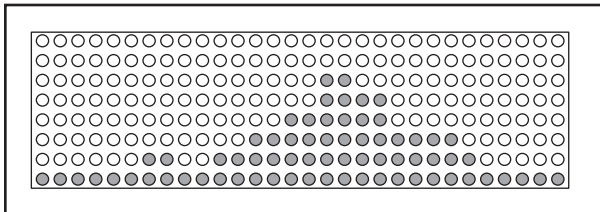

3. Enter program settings.

See steps 3 to 5 on page 25.

If you have selected the PEAKS or ALL-TERRAIN program, continue to step 4. If you have selected the HILL program, skip to step 5.

4. Enter a maximum incline setting.

The words MAX INCLINE and the incline setting will appear in the display. To enter a different maximum incline setting for your workout, press the + and – buttons beside the ENTER button; hold down the buttons to enter the maximum incline quickly. Then, press the ENTER button **and skip to step 9.**

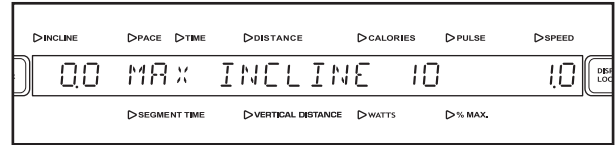

5. Enter a vertical distance goal.

The words VERTICAL DISTANCE and the vertical distance goal will appear in the display. To enter a different vertical distance goal, press the + and – buttons beside the ENTER button; hold down the buttons to enter the goal quickly. Then, press the ENTER button.

6. Enter a speed setting.

The words ENTER SPEED and the speed setting will appear in the display. To enter a different speed setting, press the + and – buttons beside the ENTER button; hold down the buttons to enter the speed quickly. Then, press the ENTER button.

7. Press the QUICK START button to start the program.

A moment after the button is pressed, the walking belt will begin to move at 3 mph for the PEAKS or ALL-TERRAIN program, or at the speed setting you entered for the HILL program. Hold the handrails and begin walking.

If the speed of the walking belt is too fast or too slow, you can change it by pressing the SPEED + and – buttons.

8. Complete the program.

See steps 10 to 12 on page 26.

HOW TO USE A FITNESS OR RANDOM PROGRAM

The FITNESS program controls the speed and incline of the incline trainer to create a workout with a warm-up period, a steady workout, and a cool-down period.

The RANDOM program creates a different incline program every time it is selected for a variety of workouts.

1. Insert the key into the console.

See GETTING STARTED on page 18.

2. Select the FITNESS program or the RANDOM program.

Press the MIX button once or twice to select the FITNESS program or the RANDOM program. When a FITNESS or RANDOM program is selected, the name of the program will appear in the display. The words ENTER AGE and the current age setting will then be shown.

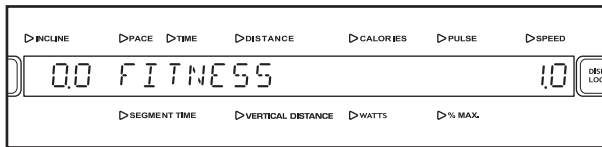

When a FITNESS program is selected, the matrix will show a graph representing the speed settings for the program.

When a RANDOM program is selected, the matrix will show a graph representing the incline settings for the program.

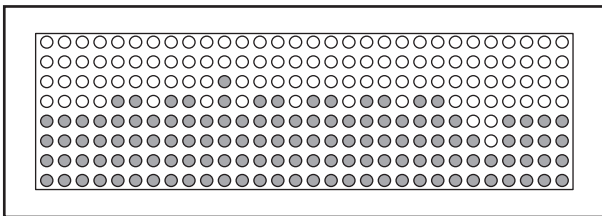

3. Enter your age.

See step 3 on page 19.

4. Enter your weight.

See step 4 on page 20.

If you have selected a RANDOM program, continue to step 5. If you have selected a FITNESS program, skip to step 7.

5. Enter a maximum incline setting.

See step 7 on page 25.

6. Enter a program time.

See step 8 on page 24.

7. Press the QUICK START button to start the program.

A moment after the button is pressed, the walking belt will begin to move at 5 mph for the FITNESS program, or at 3 mph for the RANDOM program. Hold the handrails and begin walking.

The speed of the walking belt will fluctuate between 5 and 8 mph throughout the FITNESS program; the speed of the walking belt will be 3 mph for the entire RANDOM program.

If the speed of the walking belt is too fast or too slow, you can change it by pressing the SPEED + and – buttons.

8. Change the incline of the incline trainer as desired.

See step 7 on page 20.

9. Follow your progress with the display.

See THE DISPLAY on page 16.

10. Measure your heart rate if desired.

See THE PULSE SENSOR on page 17.

11. When the program is completed, remove the key.

See step 10 on page 20.

HOW TO USE A CUSTOM PROGRAM

1. Insert the key into the console.

See GETTING STARTED on page 18.

2. Select the CUSTOM programs.

To select the CUSTOM programs, press the MIX button repeatedly. The name of the currently selected CUSTOM program will appear in the display. There are three CUSTOM programs. To select a different CUSTOM program, press the + and – buttons beside the ENTER button. When you see the CUSTOM program you want, press the ENTER button.

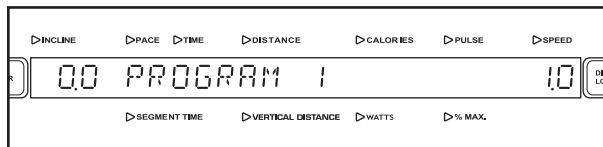

Note: The matrix will show the incline settings of the program. If only three rows of indicators appear in the matrix, see HOW TO USE THE MAINTENANCE MODE on page 31, and follow the instructions to step 6.

3. Enter your age.

See step 3 on page 19.

4. Enter your weight.

See step 4 on page 20.

5. Press the QUICK START button to start the program.

A moment after the button is pressed, the incline trainer will automatically adjust to the first speed and incline settings of the program. Hold the handrails and begin walking.

Each CUSTOM program is divided into several segments. One speed setting and one incline setting is programmed for each segment. (The same speed and/or incline setting may be programmed for two or more consecutive segments.) The incline setting for the first segment is shown in the flashing column of the matrix. The incline settings for the next several segments are shown in the columns to the right.

After every 30 seconds that you exercise, a tone will sound and the next column to the right will begin to flash.

Note: If the length of the program exceeds the number of columns in the matrix, the same column will continue to flash, and *all columns of indicators will shift one position to the left* once you have exercised for 7 1/2 minutes. The columns of indicators will continue to shift to the left after every 30 seconds, until you are finished exercising.

To stop the program temporarily, press the STOP button. The time will begin to flash. To restart the program, press the QUICK START button.

6. Follow your progress with the display.

See THE DISPLAY on page 16.

7. Measure your heart rate if desired.

See THE PULSE SENSOR on page 17.

8. When the program is completed, remove the key.

See step 10 on page 20.

HOW TO USE THE MAINTENANCE MODE

The console features a maintenance mode that allows you to access information and to view and change various default settings. Follow the steps below to use the maintenance mode.

1. Insert the key into the console.

See GETTING STARTED on page 18.

2. Hold down the ENTER button and the CLEAR button simultaneously for two seconds to select the maintenance mode.

When the maintenance mode is selected, the words MAINTENANCE MODE will appear in the display. The word HOURS and the total number of hours that the incline trainer has been used will then be shown.

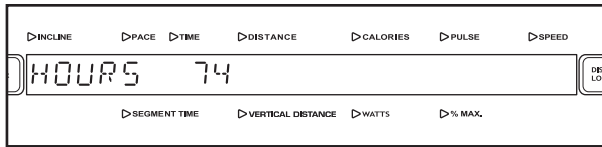

3. Press the ENTER button to view the total distance that the walking belt has moved.

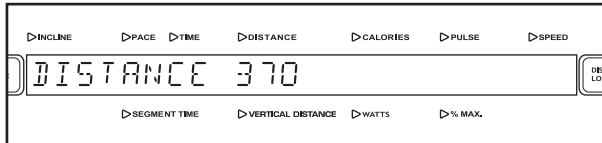

4. Press the ENTER button again and set a maximum program time.

To set a maximum program time, press the + and – buttons beside the ENTER button. The maximum program time can be up to 90 minutes.

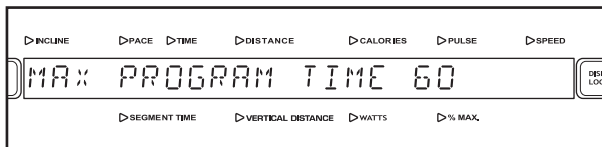

5. Press the ENTER button again and set the delay time for the timeout mode.

Any time that the incline trainer is not used for several minutes, the console will enter a timeout mode and the words SELECT PROGRAM TO BEGIN will appear in the display. To set the number of seconds before the console will enter the timeout mode, press the + and – buttons above the ENTER button. The delay time can be from 15 to 120 seconds.

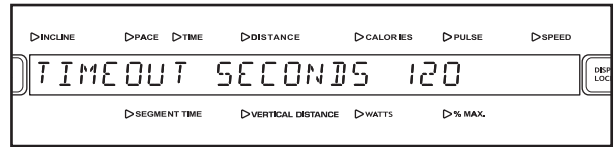

6. Press the ENTER button again to create the CUSTOM programs.

The words CUSTOM PROGRAM will appear in the display.

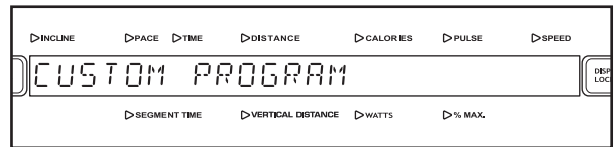

You can design up to three CUSTOM programs. To select a CUSTOM program, press the + and – buttons beside the ENTER button. When you see the CUSTOM program you want to design (PROGRAM 1, PROGRAM 2, or PROGRAM 3), press the ENTER button.

Note: If the CUSTOM program has not yet been defined, only three rows of indicators will appear in the matrix.

Enter a name for the program. The name can have up to twelve characters, including spaces. To enter a name, press the + and – buttons beside the ENTER button until the desired character appears in the display. Then, press the ENTER button. If you select the wrong character, press the CLEAR button. Continue entering a name in this way. Then, press the ENTER button.

Next, enter a program time by pressing the + and – buttons beside the ENTER button. Then, press the ENTER button.

See the matrix. Each CUSTOM program is divided into 30-second segments. One speed setting and one incline setting can be programmed for each segment. The incline setting for the first segment is shown in the flashing column of the matrix.

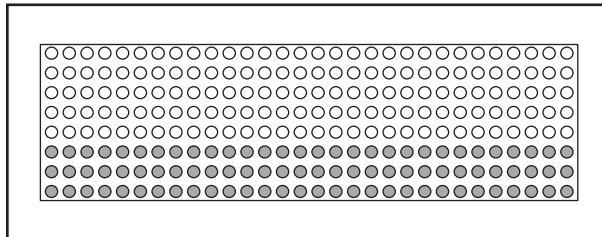

Enter a maximum incline setting for the first segment of the program by pressing the QUICK-TOUCH INCLINE buttons and the + and – buttons beside the ENTER button. Next, enter a speed setting for the first segment of the program by pressing the SPEED + and – buttons. Then, press the ENTER button. Note: The maximum incline setting will appear in the first column of the matrix. The speed settings of the program will not appear in the matrix.

Program a speed setting and an incline setting for the second segment as described above.

Continue programming speed and incline settings for the remaining segments. After you have entered the last incline setting, the words CUSTOM PROGRAM CREATED will appear in the display. The speed and incline settings that you have programmed and the number of segments that you have programmed will then be saved in memory and you will be returned to the maintenance mode.

7. Press the ENTER button again and set the delay time for the sleep timeout mode.

Any time that the incline trainer is not used for several minutes, the console will enter a sleep timeout mode. To set the number of minutes before the console will enter the sleep timeout mode, press the + and – buttons above the ENTER button. The delay time can be from 1 to 10 minutes.

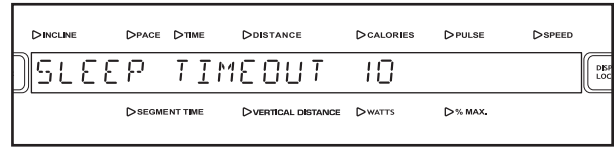

If you have the Basic console, skip to step 9. If you have the Workout TV console, continue to step 8.

8. Press the ENTER button again and enable or disable the TV.

To make the TV available for use, press the + or – button above the ENTER button until the words TV ON appear in the display. To prevent the TV from being used, press the + or – button until the words TV OFF appear.

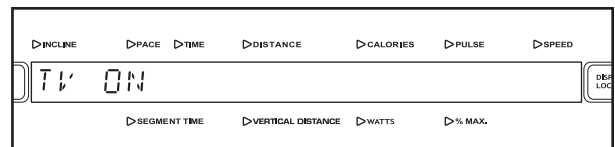

9. Hold down the ENTER button and the CLEAR button simultaneously for two seconds to exit the maintenance mode.

To exit the maintenance mode at any time, hold down the ENTER button and the CLEAR button simultaneously for two seconds.

HOW TO ENABLE OR DISABLE THE SAFETY KEY

If your INCLINE TRAINER is connected to a 120-volt circuit, you can disable the safety key so the INCLINE TRAINER does not require the use of a key. **If your INCLINE TRAINER is connected to a 220-volt circuit, you cannot disable the safety key.**

1. Remove the key from the console.

Make sure the key is not inserted into the console; the display will appear blank.

2. Hold down the ENTER button and the CLEAR button simultaneously for two seconds to select the maintenance mode.

When the maintenance mode is selected, the words MAINTENANCE MODE will appear in the display.

3. Press the ENTER button repeatedly to enable or disable the safety key.

Press the ENTER button repeatedly until the words SAFETY KEY ENABLED appear in the display.

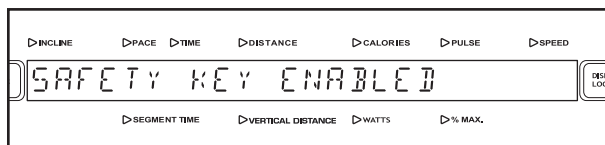

To allow the INCLINE TRAINER to be used without the safety key, press the + or – button until the words SAFETY KEY DISABLED appear. Note: The next time the key is inserted into the console, the safety key will automatically be enabled and the console will require the use of the safety key again.

To require the use of the safety key with the console, press the + or – button above the ENTER button until the words SAFETY KEY ENABLED appear in the display, or insert the key into the console.

4. Hold down the ENTER button and the CLEAR button simultaneously for two seconds to exit the maintenance mode.

To exit the maintenance mode, hold down the ENTER button and the CLEAR button simultaneously for two seconds.

PREVENTIVE MAINTENANCE

Regular maintenance is necessary for optimal performance and long life of the incline trainer. Please read and follow all instructions below. If the incline trainer is not maintained as described, components may wear excessively, the incline trainer may be damaged, and the warranty will be voided. If you have questions about maintenance, please see the back cover of this manual. **CAUTION: Make sure to remove the key and unplug the power cord before performing any maintenance procedures.**

WEEKLY MAINTENANCE

1. **Unplug the power cord.** Inspect and properly tighten all external parts of the incline trainer.
2. Apply a mild multi-purpose cleaner to a 100% cotton cloth and remove any dust and grime from the handrails, uprights, foot rails, frame, and motor hood. In addition, wipe the walking platform along the sides of the walking belt. **Do not use cleaners under the walking belt.** Apply a small amount of mild multi-purpose cleaner to a 100% cotton cloth and wipe the console and the screens. **Do not spray cleaner directly onto the incline trainer or use ammonia or acid-based cleaners.**
3. Make sure that the walking belt is centered and properly tightened. If it is centered and runs smoothly, do not make any adjustments. If the walking belt needs to be adjusted, see pages 38 and 39.

MONTHLY MAINTENANCE

1. **Unplug the power cord.** Remove the Hood Support Bolts (37) attaching the Motor Hood (91), and lift off the Motor Hood.

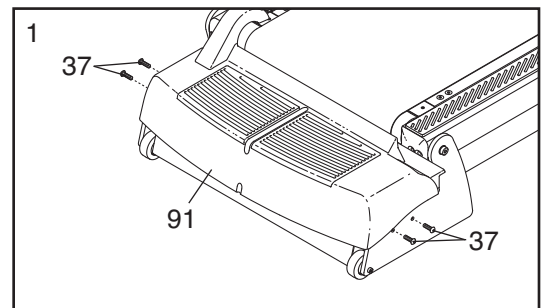

2. Using a hand-held vacuum, clean the area under the Motor Hood (not shown). **Be careful to avoid touching any components.** Check the Drive Motor Belt (82) for wear and cracks. If the motor belt needs to be replaced, please see the back cover of this manual.

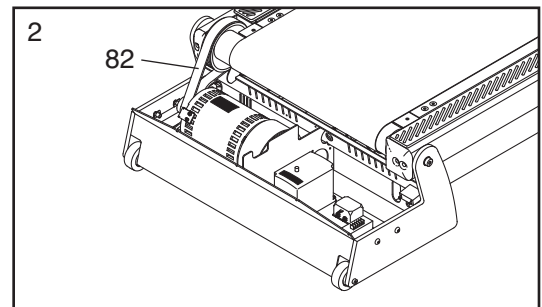

3. Plug in the power cord and insert the key into the console. Press the QUICK START button. **Be careful to avoid injury; keep your hands away from moving parts and make sure that your clothes cannot become caught in moving parts.** While the walking belt is moving, check the incline trainer for unusual noises or odors. If any of these problems exists, please see the back cover of this manual. **Remove the key and unplug the power cord.** Reattach the Motor Hood (91) with the Hood Support Bolts (37).
4. Hold a clean, dry towel between the walking platform and the walking belt. Pull the towel from side to side along the length of the walking platform. Rotate the walking belt and repeat this step until the entire walking belt has been cleaned.

TURNING THE WALKING PLATFORM

Both sides of the walking platform are designed to be used as walking surfaces. Inspect the walking platform periodically for wear. If there is any wood showing through the phenolic coating, or if the surface is damaged, the walking platform should be turned over. The walking platform will need to be turned over and the walking belt replaced (see page 36) after every 16,000 to 24,000 kilometers (10,000 to 15,000 miles). Follow the instructions below to turn over the walking platform.

1. **Remove the key and unplug the power cord.** Remove the #8 x 3/4" Screws (16), Cover Screws (2) and the Front Cover (17). Remove the Front Roller Adjustment Bolt (19) and the Front Roller Washer (14) from each side of the Front Roller (13).

2. Remove the four Rear Walking Platform Bolts (10) and the two Front Walking Platform Bolts (20). **(Note: Be very careful to avoid chipping or damaging the phenolic coating on the Walking Platform [23].)** Lift the Front Roller (13) and slide it out of the Walking Belt (18). Lift the Walking Platform and the Walking Belt to the position shown by the dotted lines. Slide the Walking Platform out of the Walking Belt, turn it, and then slide it back into the Walking Belt.

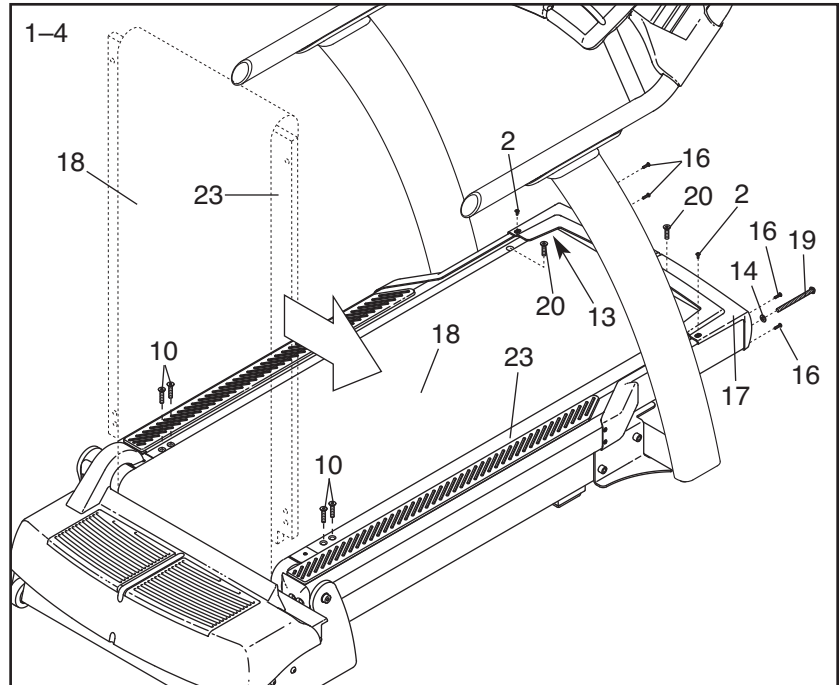

3. Lay down the Walking Platform (23) and the Walking Belt (18). Slide the Front Roller (13) back into the Walking Belt.

4. Reattach the Walking Platform Bolts (10, 20). Thread the Front Roller Adjustment Bolts (19) with the Washers (14) into the Roller (13). Reattach the Front Cover (17) with the #8 x 3/4" Screws (16) and Cover Screws (2).

5. Next, the Walking Belt (18) will need to be adjusted to the proper tension. Using chalk, make two marks on the Walking Belt exactly 1.25 m (50 in.) apart, as shown in the drawing. Tighten both Front Roller Adjustment Bolts (19, see the drawing above) until the two chalk marks move apart an additional 5 to 6 mm (3/16 to 1/4 in.). As you tighten the Roller Adjustment Bolts, the Front Roller (13) will move. **If the Front Roller stops moving, do not further tighten the Roller Adjustment Bolts; please see the back cover of this manual.** Make sure to keep the Walking Belt centered.

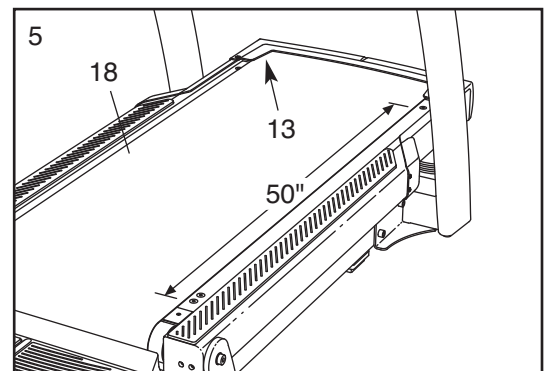

REPLACING THE WALKING BELT

When the walking belt becomes worn, it should be replaced. The walking belt will need to be replaced after every 16,000 to 24,000 kilometers (10,000 to 15,000 miles). See the Service Manual for replacement instructions. Please see the back cover of this manual to order a new walking belt.

REPLACING THE WALKING PLATFORM

When both sides of the walking platform become worn, the walking platform should be replaced. The walking platform will need to be replaced after every 32,000 to 48,000 kilometers (20,000 to 30,000 miles). Please see the back cover of this manual to order a new walking platform. Follow the instructions on page 35 to replace the walking platform.

SIX-MONTH PREVENTIVE MAINTENANCE RECORD

Photocopy this form and use it to record the preventive maintenance performed on the incline trainer. Each copy of the form can be used for six months (26 weeks). When maintenance is performed, write the date in the appropriate spaces. **Make sure to perform each maintenance procedure as described on pages 34 to 36. If the procedures are not performed as described, components may wear excessively, the incline trainer may be damaged, and the warranty will be voided.**

	Weekly Maintenance			Monthly Maintenance		
	Inspect and tighten all external parts of the incline trainer.	Clean the incline trainer.	Check the walking belt for proper tension and alignment.	Remove the motor hood and vacuum the motor compartment.	Check the motor belt for cracks and other wear.	Check the motor for arcing; check for noises or odors.
Week 1	/ /	/ /	/ /			
Week 2	/ /	/ /	/ /			
Week 3	/ /	/ /	/ /			
Week 4	/ /	/ /	/ /	/ /	/ /	/ /
Week 5	/ /	/ /	/ /			
Week 6	/ /	/ /	/ /			
Week 7	/ /	/ /	/ /			
Week 8	/ /	/ /	/ /	/ /	/ /	/ /
Week 9	/ /	/ /	/ /			
Week 10	/ /	/ /	/ /			
Week 11	/ /	/ /	/ /			
Week 12	/ /	/ /	/ /			
Week 13	/ /	/ /	/ /	/ /	/ /	/ /
Week 14	/ /	/ /	/ /			
Week 15	/ /	/ /	/ /			
Week 16	/ /	/ /	/ /			
Week 17	/ /	/ /	/ /	/ /	/ /	/ /
Week 18	/ /	/ /	/ /			
Week 19	/ /	/ /	/ /			
Week 20	/ /	/ /	/ /			
Week 21	/ /	/ /	/ /	/ /	/ /	/ /
Week 22	/ /	/ /	/ /			
Week 23	/ /	/ /	/ /			
Week 24	/ /	/ /	/ /			
Week 25	/ /	/ /	/ /			
Week 26	/ /	/ /	/ /	/ /	/ /	/ /

Walking Platform Turned/Replaced	/ /	/ /	Walking Belt Replaced	/ /
----------------------------------	-----	-----	-----------------------	-----

TROUBLESHOOTING

Most incline trainer problems can be solved by following the steps below. Find the symptom that applies, and follow the steps listed. If further assistance is needed, please see the back cover of this manual.

1. SYMPTOM: THE POWER DOES NOT TURN ON

- a. Make sure that the power cord is plugged into a properly grounded outlet. (See page 12.)
- b. Make sure that the key is inserted into the console.
- c. Check the power switch located on the incline trainer near the power cord. Make sure that the power switch is pressed into the on position.

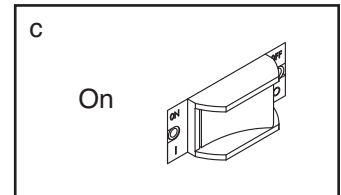

2. SYMPTOM: THE POWER TURNS OFF DURING USE

- a. Check the power switch located on the incline trainer near the power cord. (See drawing 1. c. above.) Make sure that the power switch is pressed into the on position.
- b. Make sure that the power cord is plugged in.
- c. Remove the key from the console. Reinsert the key into the console.
- d. Check the walking belt and the walking platform for excessive wear. Replace the walking belt or the walking platform if necessary.
- e. If the power still turns off during use, please see the back cover of this manual.

3. SYMPTOM: THE WALKING BELT SLOWS WHEN WALKED ON

- a. If the walking belt is overtightened, performance may decrease and the walking belt may be damaged. If the walking belt is properly tightened, you should be able to lift each side of the walking belt 2.5 to 5 cm (1 to 2 in.) off the walking platform. **If adjustments need to be made, first remove the key and unplug the power cord.** Using a 7/32" hex key, turn both roller adjustment bolts counterclockwise 1/4 of a turn. Then, plug in the power cord, insert the key, and use the incline trainer for a few minutes. Be careful to keep the walking belt centered. Repeat until the walking belt is properly tightened. Note: To tighten the walking belt, see step 4. c. on page 39.

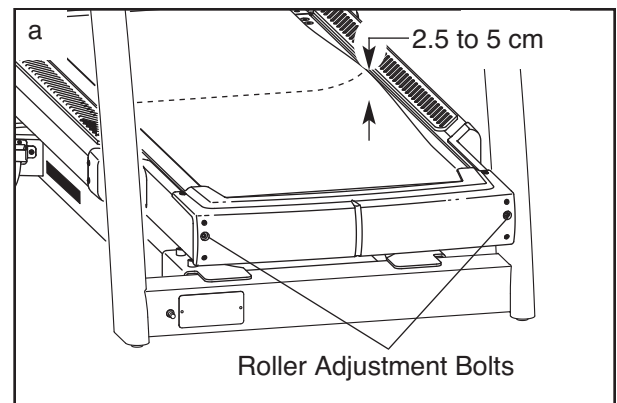

- b. If the walking belt still slows when walked on, please see the back cover of this manual.

4. SYMPTOM: THE WALKING BELT IS OFF-CENTER OR SLIPS WHEN WALKED ON

- a. **If the walking belt has shifted to the right: Remove the key and unplug the power cord.** Using a 7/32" hex key, turn the roller adjustment bolts in the directions shown, 1/4 of a turn each. Be careful not to overtighten the walking belt. Then, plug in the power cord, insert the key, and use the incline trainer for a few minutes. Repeat until the walking belt is centered.

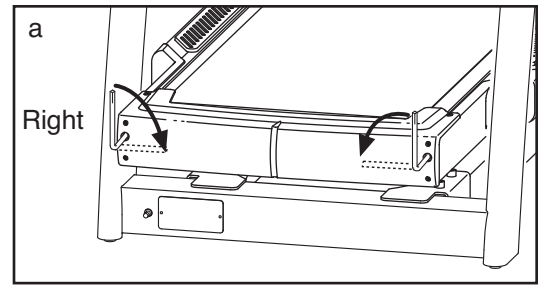

- b. **If the walking belt has shifted to the left: Remove the key and unplug the power cord.** Using a 7/32" hex key, turn the roller adjustment bolts in the directions shown, 1/4 of a turn each. Be careful not to overtighten the walking belt. Then, plug in the power cord, insert the key, and use the incline trainer for a few minutes. Repeat until the walking belt is centered.

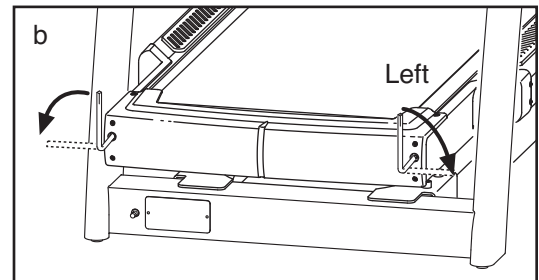

- c. **If the walking belt slips when walked on: Remove the key and unplug the power cord.** Using a 7/32" hex key, turn both roller adjustment bolts clockwise 1/4 of a turn. When the walking belt is properly tightened, you should be able to lift each side of the walking belt 2.5 to 5 cm (1 to 2 in.) off the walking platform. The center of the walking belt should just touch the walking platform. Make sure to keep the walking belt centered. Then, plug in the power cord, insert the key, and run the incline trainer for a few minutes. Repeat until the walking belt is properly tightened. Note: As you tighten the roller adjustment bolts, the front roller will move. **If the front roller stops moving, do not further tighten the roller adjustment bolts; please see the back cover of this manual.**

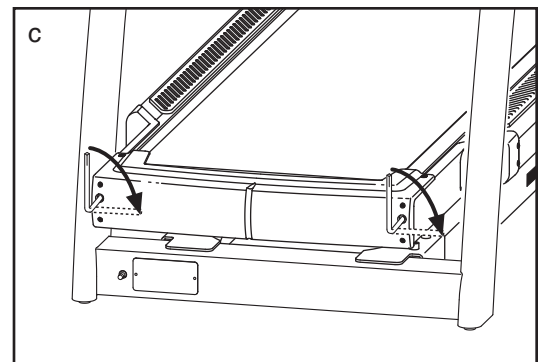

5. SYMPTOM: THE WALKING BELT STOPS OR THE INCLINE CANNOT BE ADJUSTED EVEN THOUGH THE CONSOLE REMAINS LIT

- a. This indicates that a controller error may have occurred. To correct the problem, turn the power switch off, wait 5 seconds and then turn the power switch back on.

6. SYMPTOM: THE INCLINE SYSTEM DOES NOT FUNCTION PROPERLY OR THE INCLINE SYSTEM DOES NOT APPEAR TO BE AT THE INCLINE LEVEL SHOWN IN THE DISPLAY

- a. The incline system may need to be calibrated. To initiate the calibration routine, turn the power switch off, wait 5 seconds and then turn the power switch back on. During the calibration routine, the incline trainer will automatically travel to the lowest incline level and then return to level.
- b. If the incline system still does not function properly, please see the back cover of this manual.

EXERCISE GUIDELINES

⚠️ WARNING: Before beginning this or any exercise program, consult your physician. This is especially important for persons over age 35 or persons with pre-existing health problems.

The pulse sensor is not a medical device. Various factors may affect the accuracy of heart rate readings. The pulse sensor is intended only as an exercise aid in determining heart rate trends in general.

These guidelines will help you to plan your exercise program. For detailed exercise information, obtain a reputable book or consult your physician. Remember, proper nutrition and adequate rest are essential for successful results.

EXERCISE INTENSITY

Whether your goal is to burn fat or to strengthen your cardiovascular system, exercising at the proper intensity is the key to achieving results. You can use your heart rate as a guide to find the proper intensity level. The chart below shows recommended heart rates for fat burning and aerobic exercise.

165	155	145	140	130	125	115	♥♥
145	138	130	125	118	110	103	♥
125	120	115	110	105	95	90	♥
<hr/>							
20	30	40	50	60	70	80	

To find the proper intensity level, find your age at the bottom of the chart (ages are rounded off to the nearest ten years). The three numbers listed above your age define your “training zone.” The lowest number is the heart rate for fat burning, the middle number is the heart rate for maximum fat burning, and the highest number is the heart rate for aerobic exercise.

Burning Fat—To burn fat effectively, you must exercise at a low intensity level for a sustained period of time. During the first few minutes of exercise, your body uses *carbohydrate calories* for energy. Only after the first few minutes of exercise does your body begin to use stored *fat calories* for energy. If your goal is to burn fat, adjust the intensity of your exercise until your heart rate is near the lowest number in your training zone. For maximum fat burning, exercise with your heart rate near the middle number in your training zone.

Aerobic Exercise—If your goal is to strengthen your cardiovascular system, you must perform aerobic exercise, which is activity that requires large amounts of oxygen for prolonged periods of time. For aerobic exercise, adjust the intensity of your exercise until your heart rate is near the highest number in your training zone.

WORKOUT GUIDELINES

Warming Up—Start with 5 to 10 minutes of stretching and light exercise. A warm-up increases your body temperature, heart rate, and circulation in preparation for exercise.

Training Zone Exercise—Exercise for 20 to 30 minutes with your heart rate in your training zone. (During the first few weeks of your exercise program, do not keep your heart rate in your training zone for longer than 20 minutes.) Breathe regularly and deeply as you exercise—never hold your breath.

Cooling Down—Finish with 5 to 10 minutes of stretching. Stretching increases the flexibility of your muscles and helps to prevent post-exercise problems.

EXERCISE FREQUENCY

To maintain or improve your condition, complete three workouts each week, with at least one day of rest between workouts. After a few months of regular exercise, you may complete up to five workouts each week, if desired. Remember, the key to success is to make exercise a regular and enjoyable part of your everyday life.

SUGGESTED STRETCHES

The correct form for several basic stretches is shown at the right. Move slowly as you stretch—never bounce.

1. Toe Touch Stretch

Stand with your knees bent slightly and slowly bend forward from your hips. Allow your back and shoulders to relax as you reach down toward your toes as far as possible. Hold for 15 counts, then relax. Repeat 3 times. Stretches: Hamstrings, back of knees and back.

2. Hamstring Stretch

Sit with one leg extended. Bring the sole of the opposite foot toward you and rest it against the inner thigh of your extended leg. Reach toward your toes as far as possible. Hold for 15 counts, then relax. Repeat 3 times for each leg. Stretches: Hamstrings, lower back and groin.

3. Calf/Achilles Stretch

With one leg in front of the other, reach forward and place your hands against a wall. Keep your back leg straight and your back foot flat on the floor. Bend your front leg, lean forward and move your hips toward the wall. Hold for 15 counts, then relax. Repeat 3 times for each leg. To cause further stretching of the achilles tendons, bend your back leg as well. Stretches: Calves, achilles tendons and ankles.

4. Quadriceps Stretch

With one hand against a wall for balance, reach back and grasp one foot with your other hand. Bring your heel as close to your buttocks as possible. Hold for 15 counts, then relax. Repeat 3 times for each leg. Stretches: Quadriceps and hip muscles.

5. Inner Thigh Stretch

Sit with the soles of your feet together and your knees outward. Pull your feet toward your groin area as far as possible. Hold for 15 counts, then relax. Repeat 3 times. Stretches: Quadriceps and hip muscles.

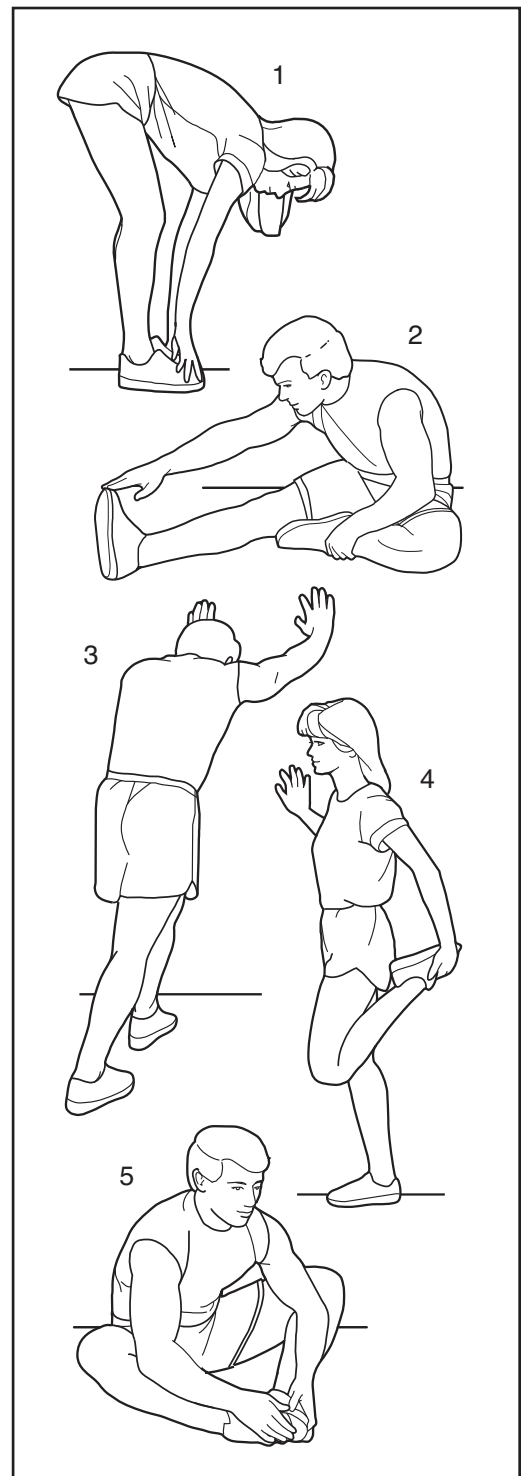

PART LIST—

R0710A

Model No. FMTK72509.0/FMTK75009.0

Key No.	Qty.	Description	Key No.	Qty.	Description
1	2	Side Cover	51	4	3/8" x 1" Bolt
2	6	Cover Screw	52	1	Drive Motor
3	4	Center Isolator	53	1	Drive Motor Isolator
4	6	Isolator Nut	54	2	Torsion Bar Bolt
5	16	Plastic Insert	55	2	Torsion Bar Bushing
6	2	Belt Guide	56	1	Base Frame
7	2	Belt Guide Spacer	57	2	Base Frame Pad
8	2	Belt Guide Bolt	58	4	Base Frame Pad Screw
9	2	Front Isolator	59	4	Incline Link Bushing
10	4	Walking Platform Bolt, Rear	60	2	Incline Link Bolt
11	1	Left Foot Pad	61	2	Incline Link Nut
12	1	Right Foot Pad	62	1	Torsion Bar
13	1	Front Roller	63	1	Power Switch
14	2	Front Roller Washer	64	1	Power Cord Bracket
15	1	Controller Box	65	1	Power Cord Receptacle
16	7	#8 x 3/4" Screw	66	2	Receptacle Bolt
17	1	Front Cover	67	1	Left Rear Roller Guard
18	1	Walking Belt	68	1	Electronics Board
19	2	Front Roller Adjustment Bolt	69	1	Torsion Bar Pivot Nut
20	2	Walking Platform Bolt, Front	70	1	Incline Link Bar
21	1	Drive Roller Assembly	71	1	Torsion Bar Pivot Bolt
22	1	Frame	72	3	Incline Motor Bushing
23	1	Walking Platform	73	1	Incline Motor
24	2	Plastic Platform Spacer	74	1	Incline Motor Pin
25	2	Rear Roller Guard Screw	75	1	Cotter Pin
26	1	Right Rear Roller Guard	76	1	Hood Support Bracket
27	2	Cage Nut	77	1	Right Hood Cover
28	1	Left Rear Endcap	78	1	Left Hood Cover
29	1	Basic Console Plate	79	2	Wheel Bolt
30	2	Rear Roller Adjustment Bolt	80	2	Hex Nut
31	2	Torsion Bar Spacer	81	2	Wheel
32	1	Right Rear Endcap	82	1	Drive Motor Belt
33	2	1/4" Stand-off	83	1	Drive Motor Flywheel
34	8	#10 x 1/2" Screw	84	1	Drive Motor Pulley
35	4	.188" Screw	85	14	1/4" x 3/4" Screw
36	1	Resistor	86	2	#8 x 3/4" Machine Screw
37	4	Hood Support Bolt	87	6	Electronics Screw
38	2	Rear Leveling Foot	88	2	Circuit Breaker Screw
39	2	Leveling Foot Nut	89	3	High Voltage Decal
40	2	Frame Pivot Bushing	90	2	Incline Motor Spacer
41	2	Frame Pivot Bolt	91	1	Motor Hood
42	4	Drive Motor Spacer	92	2	Handrail Bracket
43	4	Drive Motor Washer	93	1	Upright
44	4	Drive Motor Bolt	94	1	Static Decal
45	1	Sensor Bracket	95	4	1/2" x 2 1/2" Bolt
46	2	Speed Sensor Nut	96	4	1/2" x 4 1/2" Bolt
47	1	Speed Sensor	97	2	Deck Maintenance Decal
48	2	Speed Sensor Bolt	98	4	Pulse Sensor
49	2	Sensor Bracket Bolt	99	4	Pulse Sensor Screw
50	2	Sensor Bracket Insert	100	4	Pulse Sensor Base

Key No.	Qty.	Description	Key No.	Qty.	Description
101	2	Grip	121	2	Caution Decal
102	4	5/16" x 2" Bolt	122	1	Hazardous Warning Decal
103	1	Handrail	123	1	Warning Decal
104	2	Handrail Endcap	124	4	1/2" Star Washer
105	1	Key/Clip	125	1	Filter
106	4	Accessory Tray Mounting Screw	126	6	1/2" Stand-off
107	1	Console TV Cable	127	4	Tall Stand-off
108	4	Upright Base Pad	128	1	Power Board
109	1	Left Accessory Tray	129	2	#8 x 1/2" Machine Screw
110	1	Right Accessory Tray	130	1	Access Plate
111	1	Basic Console	131	2	Thrust Washer
112	8	Console Plate Screw	132	2	Cable Tie
113	1	Power Cord	133	1	Frame Wire Harness
114	2	Roller Insert	134	1	Ferrite Clamp
115	1	Console	135	1	Console Wire Harness
116	1	Upright TV Cable	136	2	5/16" x 1 3/4" Bolt
117	2	Cable Nuts	137	1	TV Console
118	1	TV Console Plate	138	1	Rear Incline Motor Spacer
119	1	Upright Wire Harness	*	1	User's Manual
120	2	1/2" Electronics Screw			

Note: Specifications are subject to change without notice. Please see the back cover of this manual for information about ordering replacement parts. *These parts are not illustrated.

EXPLODED DRAWING A— Model No. FMTK72509.0/FMTK75009.0

R0710A

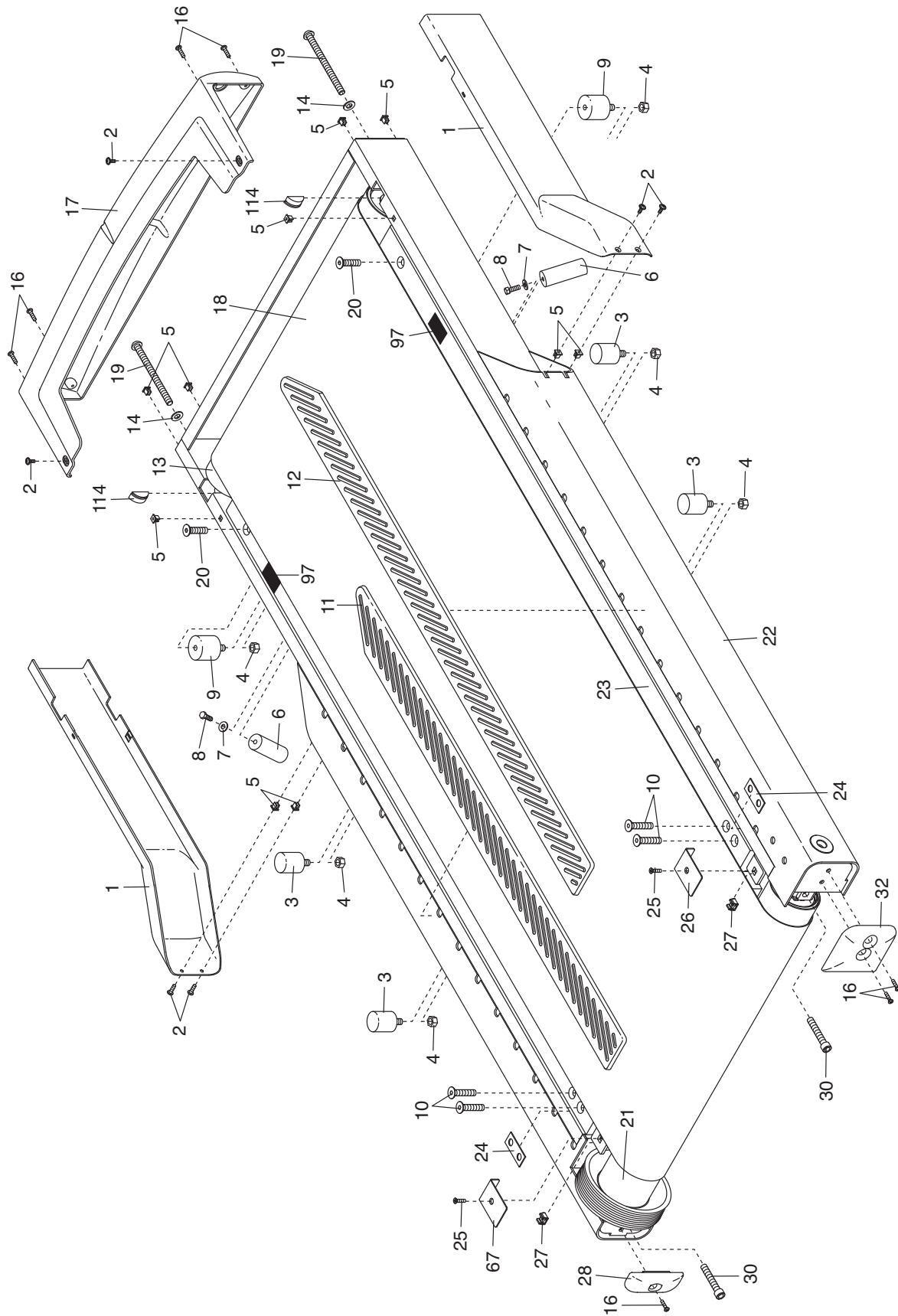

EXPLODED DRAWING B— Model No. FMTK72509.0/FMTK75009.0

R0710A

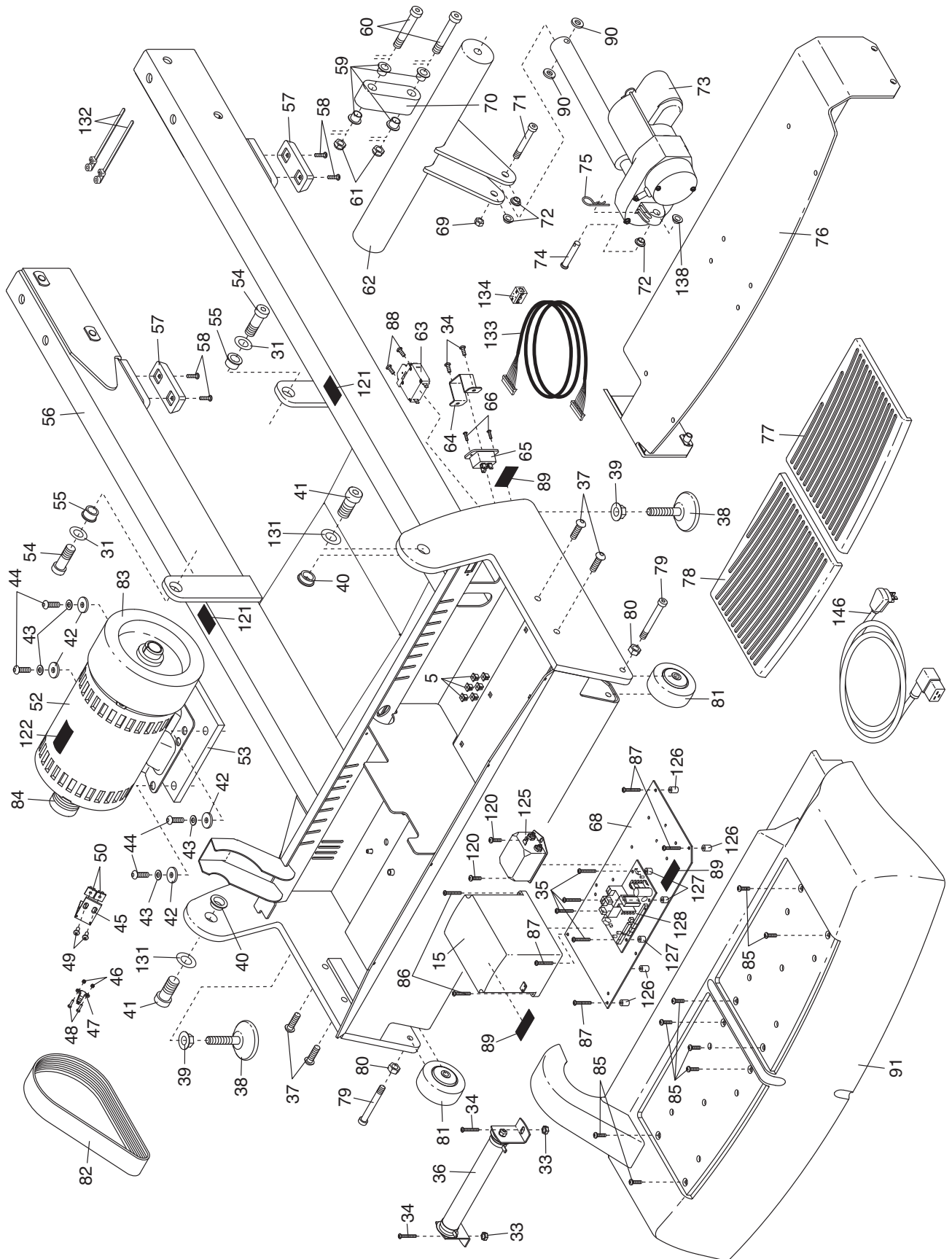

HOW TO CONTACT CUSTOMER CARE

If you have questions after reading this manual, or if parts are damaged or missing, please contact Customer Care at one of the phone numbers or addresses listed below. **Please note the model number, serial number, and name of the product (see the front cover of this manual) before contacting Customer Care. If you are ordering replacement parts, please also note the key number and description of each part (see the PART LIST and the EXPLODED DRAWING near the end of this manual).**

In the United States and Canada

Call: 1-800-201-2109, Mon.–Fri. 8 a.m.–5 p.m. MT

Write:

FreeMotion Fitness
1500 South 1000 West
Logan, UT 84321-9813
United States

Outside the United States and Canada

Call: 001-435-786-3521

Email: intlcustomercare@freemotionfitness.com