

# FREEMOTION® f5.8

[www.freemotionfitness.com](http://www.freemotionfitness.com)

Model No. SFSR82308.0

Serial No. \_\_\_\_\_

Write the serial number in the space above for reference.

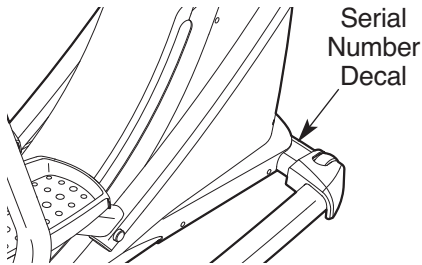

## USER'S MANUAL

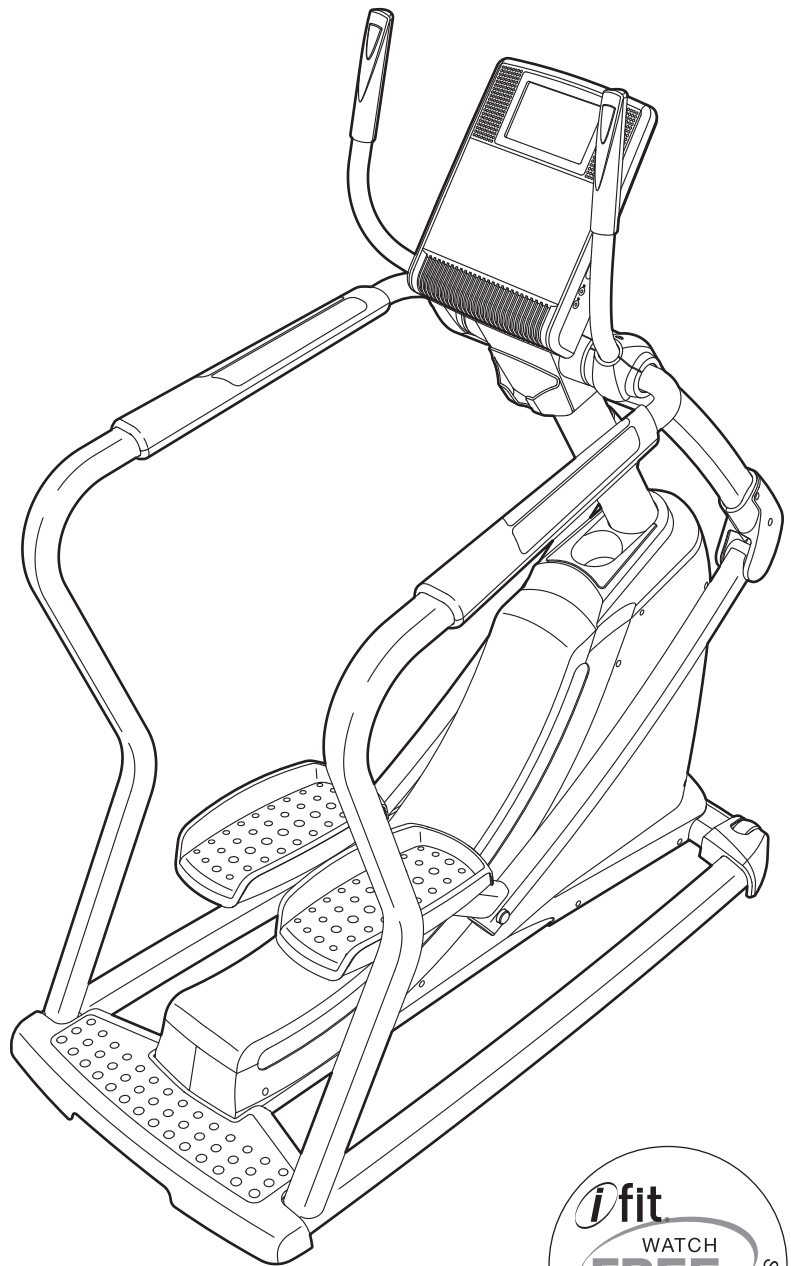

### QUESTIONS?

If you have questions, or if parts are damaged or missing, **CONTACT THE STORE WHERE YOU PURCHASED THIS PRODUCT.**

If you are unable to contact the store, see **HOW TO CONTACT CUSTOMER CARE** on the back cover of this manual.

### CAUTION

Read all precautions and instructions in this manual before using this equipment. Keep this manual for future reference.



# TABLE OF CONTENTS

WARNING DECAL PLACEMENT .....2

IMPORTANT PRECAUTIONS .....3

BEFORE YOU BEGIN .....5

ASSEMBLY .....6

HOW TO CONNECT THE PERSONAL TELEVISION .....12

HOW TO USE THE CHEST PULSE SENSOR .....13

HOW TO USE THE ELLIPTICAL STRIDER .....14

MAINTENANCE AND TROUBLESHOOTING .....26

EXERCISE GUIDELINES .....29

PART LIST .....31

EXPLODED DRAWING .....33

HOW TO CONTACT CUSTOMER CARE .....Back Cover

LIMITED WARRANTY .....Back Cover

## WARNING DECAL PLACEMENT

This drawing shows the location(s) of the warning decal(s). **If a decal is missing or illegible, see the back cover of this manual and request a free replacement decal. Apply the decal in the location shown.**  
 Note: The decal(s) may not be shown at actual size.

**WARNING**

- Misuse of this machine may result in serious injury.
- Read user's manual prior to use and follow all warnings and instructions.
- Do not allow children on or around machine.
- Pedals continue to spin when you stop pedaling.
- Spinning pedals can cause injury.
- Reduce pedal speed in a controlled manner.
- User weight must not exceed 350 pounds.
- Replace label if damaged, illegible, or removed.

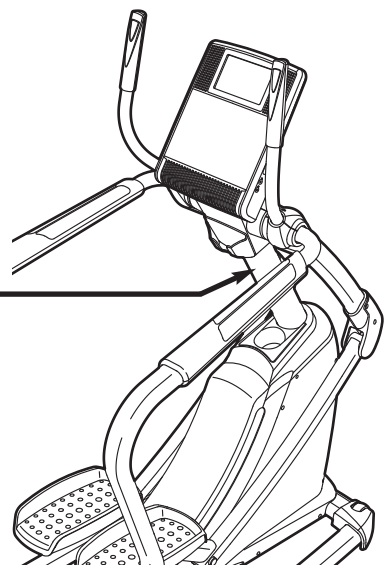
# IMPORTANT PRECAUTIONS

**⚠ WARNING:** To reduce the risk of serious injury, read all important precautions and instructions in this manual and all warnings on your elliptical strider before using your elliptical strider. FreeMotion Fitness assumes no responsibility for personal injury or property damage sustained by or through the use of this product.

1. Before beginning any exercise program, consult your physician. This is especially important for persons over age 35 or persons with pre-existing health problems.
2. It is the responsibility of the owner to ensure that all users of the elliptical strider are adequately informed of all precautions.
3. The elliptical strider is intended for home use only. Do not use the elliptical strider in a commercial, rental, or institutional setting.
4. Keep the elliptical strider indoors, away from moisture and dust. Place the elliptical strider on a level surface, with a mat beneath it to protect the floor or carpet. Make sure that there is at least 3 ft. (0.9 m) of clearance in the front and rear of your elliptical strider and 2 ft. (0.6 m) on each side.
5. Inspect and properly tighten all parts regularly. Replace any worn parts immediately.
6. Keep children under age 12 and pets away from the elliptical strider at all times.
7. The elliptical strider should not be used by persons weighing more than 350 lbs. (159 kg).
8. Wear appropriate exercise clothes while using the elliptical strider. Always wear athletic shoes for foot protection while exercising.
9. Hold the handlebars or the handrails when mounting, dismounting, or using the elliptical strider.
10. The pulse sensor is not a medical device. Various factors may affect the accuracy of heart rate readings. The pulse sensor is intended only as an exercise aid in determining heart rate trends in general.
11. Keep your back straight while using the elliptical strider; do not arch your back.
12. If you feel pain or dizziness while exercising, stop immediately and cool down.
13. When you stop exercising, allow the pedals to slowly come to a stop.
14. Use the elliptical strider only as described in this manual.
15. **DANGER:** Always unplug the power cord immediately after use, before cleaning the elliptical strider, and before performing the maintenance and adjustment procedures. Servicing other than the procedures in this manual should be performed by an authorized service representative only.
16. Do not store the television in temperatures below -40° F (-40° C) or above 140° F (60° C). Do not operate the television in temperatures below 23° F (-5° C) or above 90° F (35° C).
17. To protect the elliptical strider and television during lightning storms, unplug the power cord from the wall outlet and disconnect the cable system. This will prevent damage due to lightning and power line surges.
18. If an outside antenna or cable system is connected, be sure that the antenna or cable system is grounded to provide some protection against voltage surges and built-up static charges. Section 810 of the National Electrical Code, ANSI/NFPA No. 70-1984, provides information with respect to proper grounding of the mast and supporting structure, grounding of the lead-in wire to an antenna discharge unit, size of grounding conductors, location of antenna discharge unit, connection to grounding electrodes, and requirements for the grounding electrode.

19. An outside antenna system should not be located in the vicinity of overhead power lines or other electric light or power circuits, or where it can fall into such power lines or circuits. When installing an outside antenna system, extreme care should be taken to keep from touching such power lines or circuits, as contact with them might be fatal.

20. To reduce the risk of electric shock, do not remove the cover or the back of the television. There are no user serviceable parts inside. Refer servicing to qualified service personnel.

21. Upon completion of any service or repairs to the elliptical strider or the television, ask the service technician to perform safety checks to confirm that the unit is in proper operating condition.

- Use No. 10 AWG (5.3mm<sup>2</sup>) copper, No. 8 AWG (8.4mm<sup>2</sup>) aluminum, No. 17 AWG (1.0mm<sup>2</sup>) copper-clad steel or bronze wire, or larger as a ground wire.

- Secure an antenna lead-in and ground wires to the house with stand-off insulators spaced from 4 to 6 feet (1.22 to 1.83 m) apart.
- Mount an antenna discharge unit as close as possible to where the lead-in enters the house.
- Use a jumper wire not smaller than No. 6 AWG (13.3mm<sup>2</sup>) copper, or the equivalent when a separate antenna-grounding electrode is used. See NEC Section 810-21 (j).

**Note to CATV system installer:** This reminder is provided to call the CATV system installer's attention to Article 820-40 of the NEC that provides guidelines for proper grounding and, in particular, specifies that the cable ground shall be connected to the grounding system of the building, as close to the point of cable entry as practical.

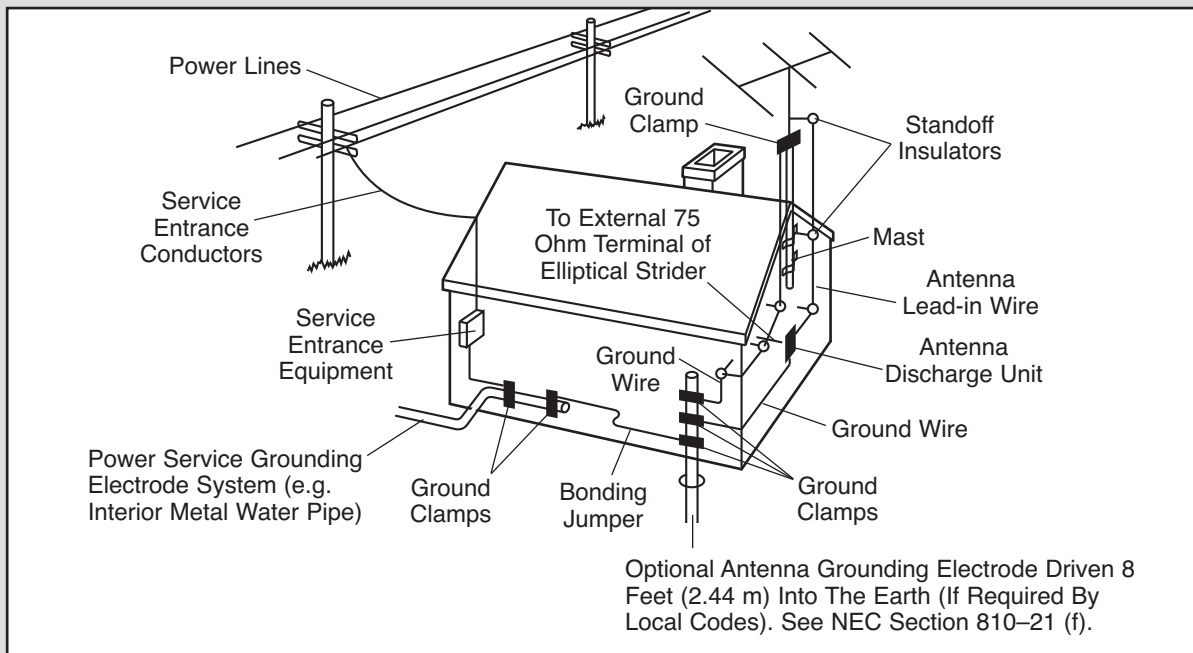

# BEFORE YOU BEGIN

Thank you for selecting the FREEMOTION® F 5.8 elliptical strider. The F 5.8 elliptical strider provides an array of features designed to make your workouts more effective and enjoyable.

**For your benefit, read this manual carefully before you use the elliptical strider.** If you have questions after reading this manual, please see the back cover

of this manual. To help us assist you, note the product model number and serial number before contacting us. The model number and the location of the serial number decal are shown on the front cover of this manual.

Before reading further, please familiarize yourself with the parts that are labeled in the drawing below.

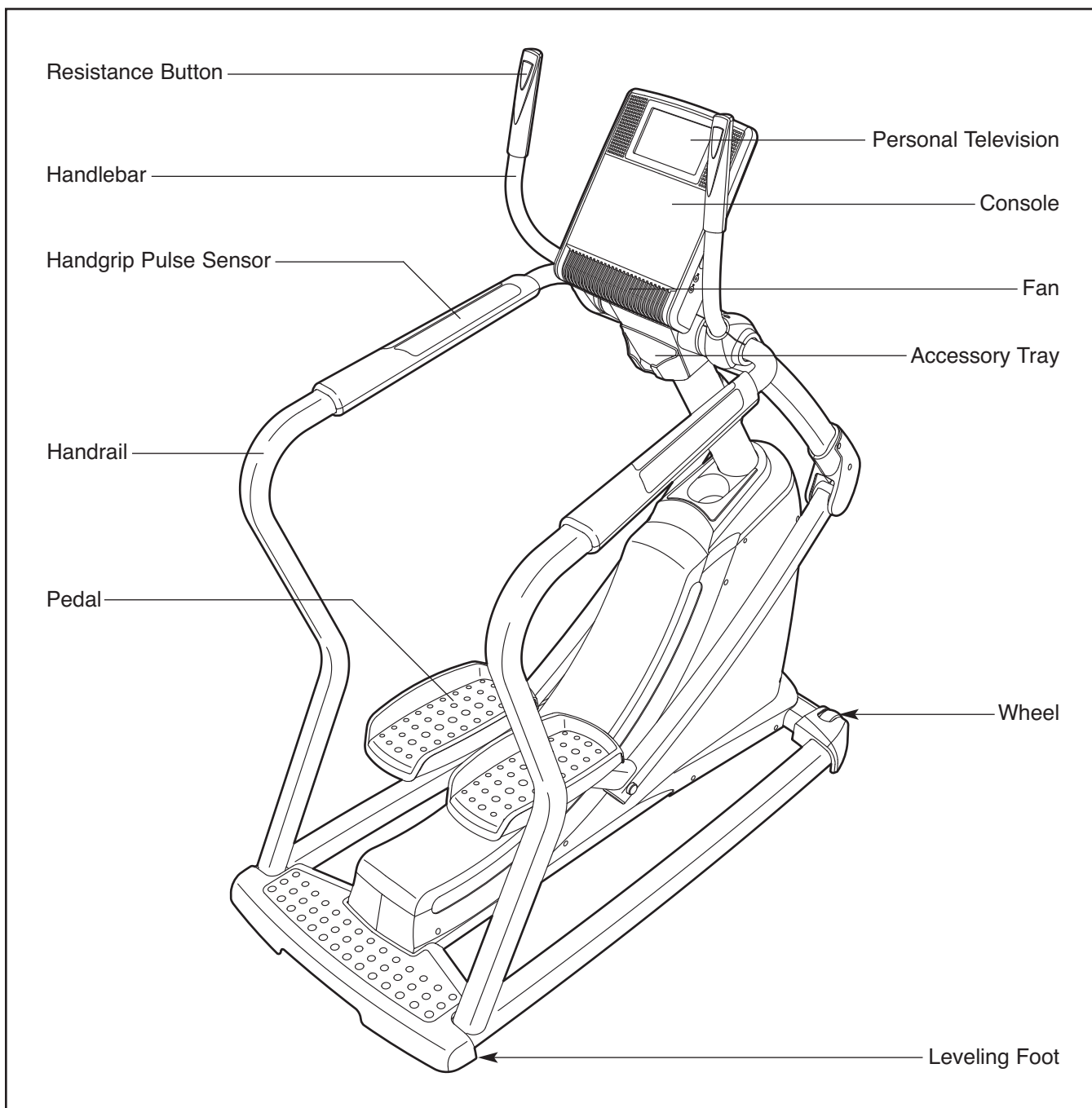

# ASSEMBLY

**Assembly requires two persons.** Place all parts of the elliptical strider in a cleared area and remove the packing materials. Do not dispose of the packing materials until assembly is completed.

**In addition to the included tool(s), assembly requires a Phillips screwdriver**  .

As you assemble the elliptical strider, use the drawings below to identify small parts. The number in parentheses below each drawing is the key number of the part, from the PART LIST near the end of this manual. The number following the parentheses is the quantity needed for assembly. **Note: Some small parts may have been pre-assembled. If a part is not in the hardware kit, check to see if it has been preassembled.**

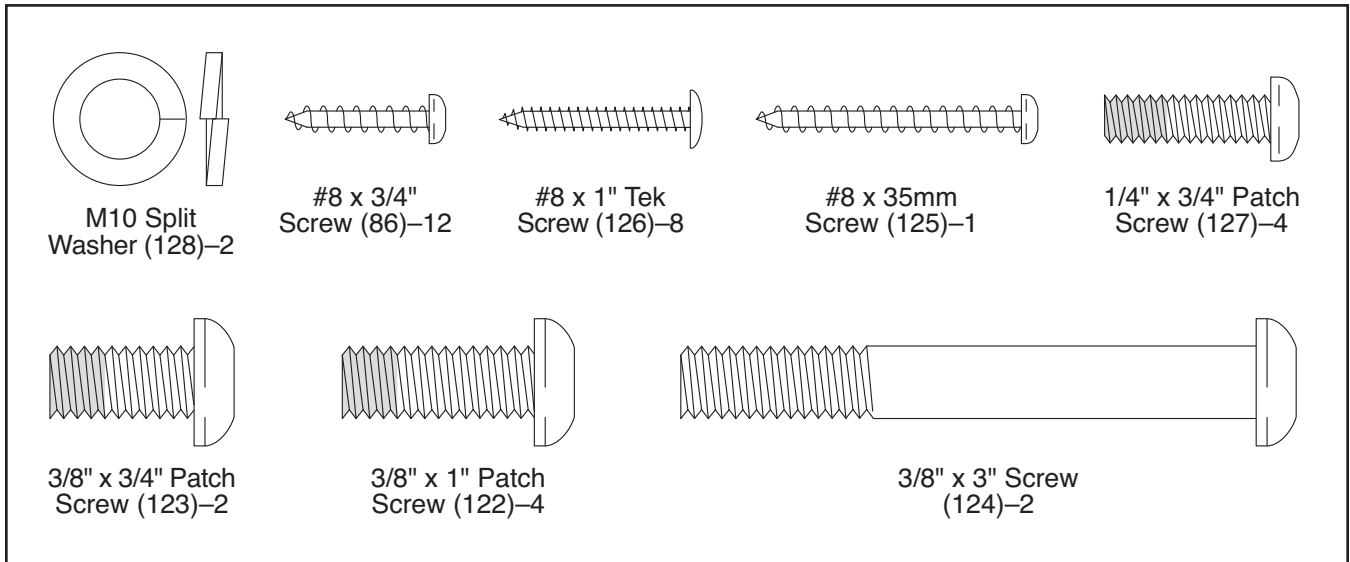

1.

To make assembly easier, read the information on page 6 before you begin.

**IMPORTANT:** Do not remove the foam block (not shown) located under the pedals until you have completed step 2.

Identify the Shield Cap (5) and the Upright (26) and orient them as shown. Slide the Shield Cap upward around the Upright.

While another person holds the Upright (26) near the Frame (1), locate the wire ties in the Upright.

**See the inset drawing.** Tie the lower end of a wire tie to the end of the Wire Harness (77). Pull the other end of the wire tie upward out of the top of the Upright (26).

Next, tie the lower end of the other wire tie to the end of the Power Cable (81). Pull the other end of the wire tie upward out of the top of the Upright (26).

Then, untie and discard the wire ties.

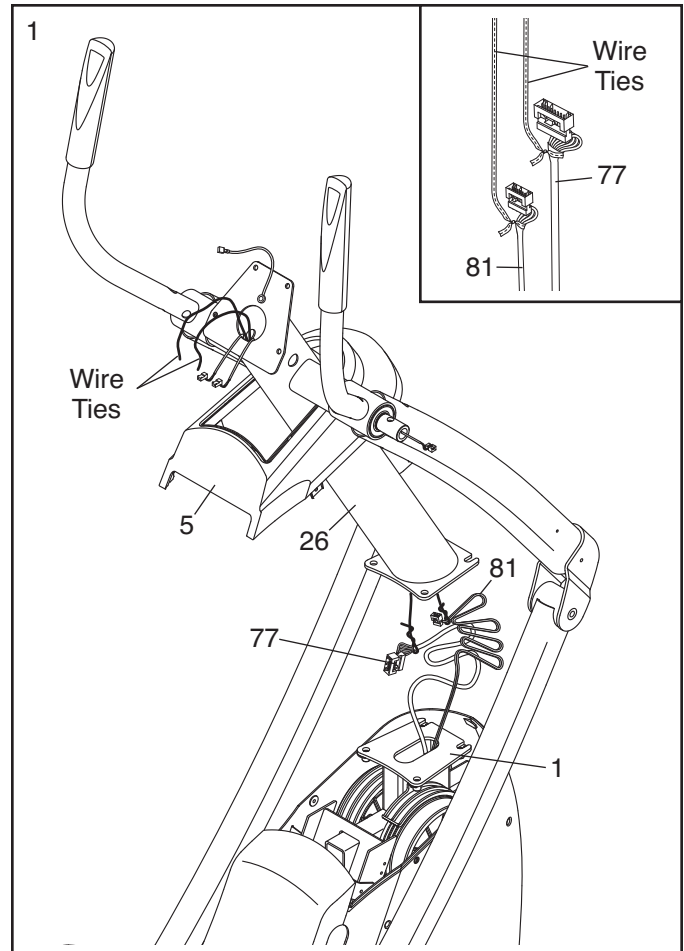

2. **Tip: Avoid pinching the wires.** Attach the Upright (26) to the Frame (1) with four 3/8" x 1" Patch Screws (122). Note: Two of the Patch Screws may be preattached to the Frame. **Tip: Start all the Patch Screws before tightening any of them.**

Remove and discard the foam block (not shown) located under the pedals.

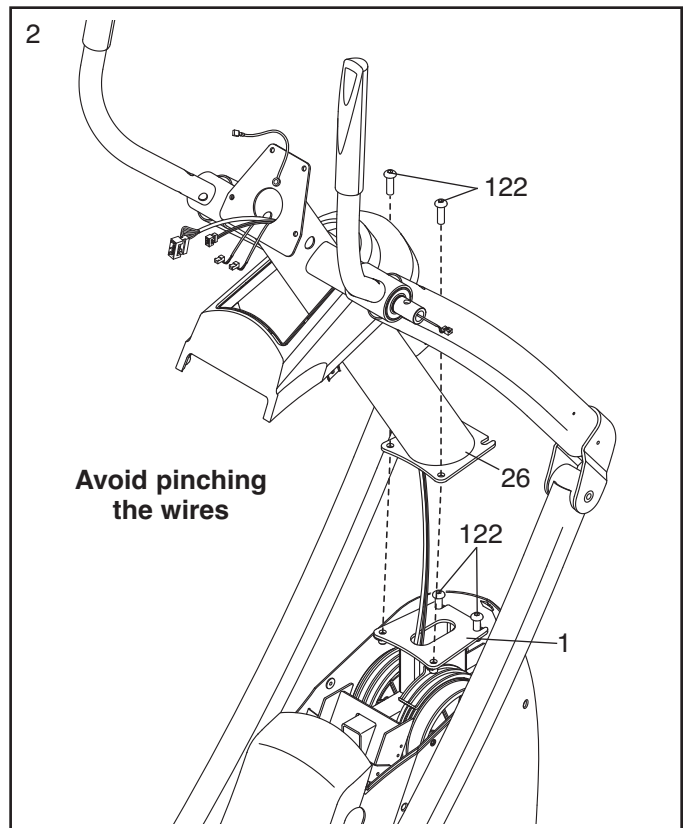

- Slide the Shield Cap (5) downward over the Right and Left Shields (6, 7).

Attach the Shield Cap (5) with a #8 x 35mm Screw (125) and two #8 x 3/4" Screws (86).

**Tip: Start all the Screws before tightening any of them.**

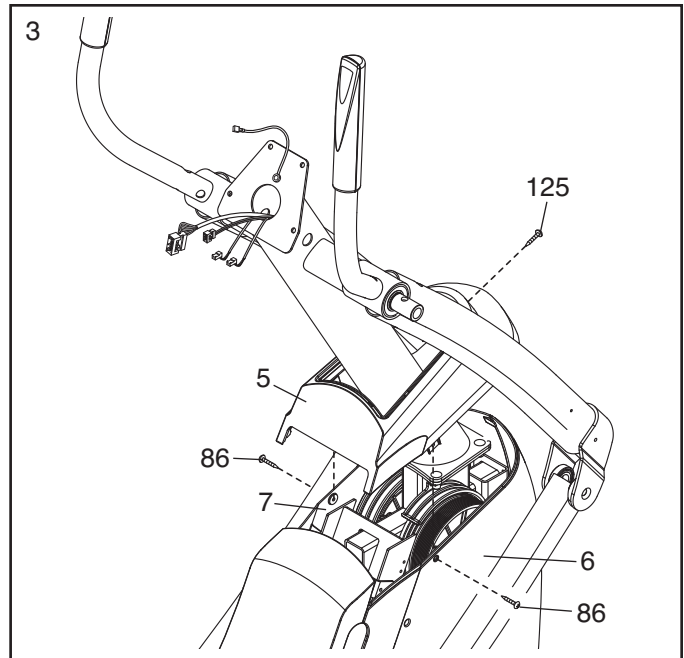

- Orient the Accessory Tray (18) as shown. Press the Accessory Tray into the Shield Cap (5).

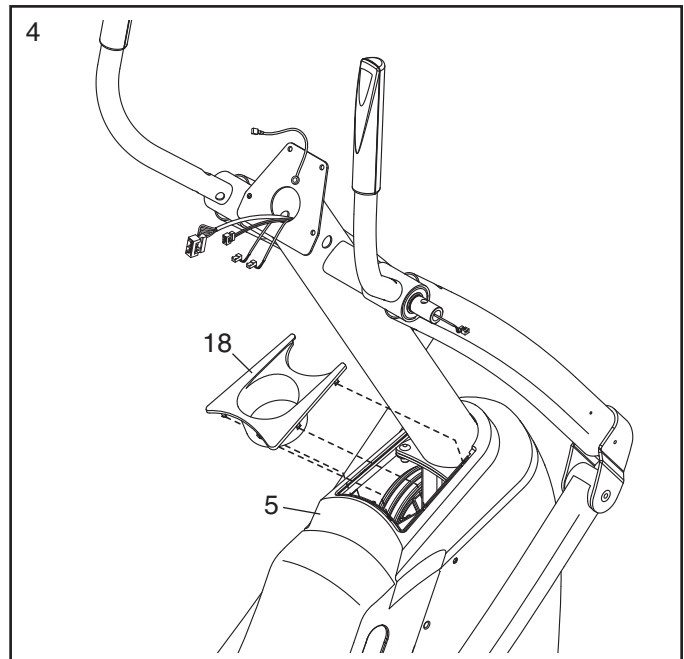



5. Identify the Right Handrail (69), which is marked with a "Right" sticker.

While another person holds the Right Handrail (69) near the Upright (26), connect the right Pulse Wire (78) to the right Sensor Wire (79).

Insert the excess wire into the Right Handrail (69). Then, slide the Right Handrail onto the Upright (26).

**Tip: Avoid pinching the wires.** Attach the Right Handrail (69) with a 3/8" x 3/4" Patch Screw (123) and an M10 Split Washer (128). **Do not tighten the Patch Screw yet.**

**Repeat this step for the Left Handrail (70).**

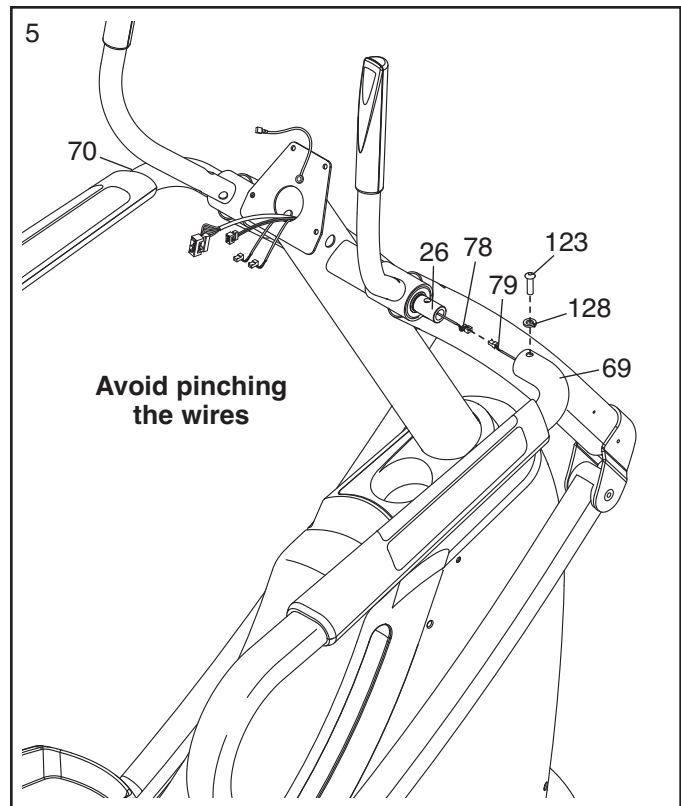

6. **IMPORTANT: To prevent damage, do not allow the elliptical strider to tip to either side during this step.**

While another person lifts the rear of the Frame (1) in the location shown by the arrow, attach each Handrail (69, 70) to the Frame with a 3/8" x 3" Screw (124).

**See step 5.** Tighten the 3/8" x 3/4" Patch Screws (123).

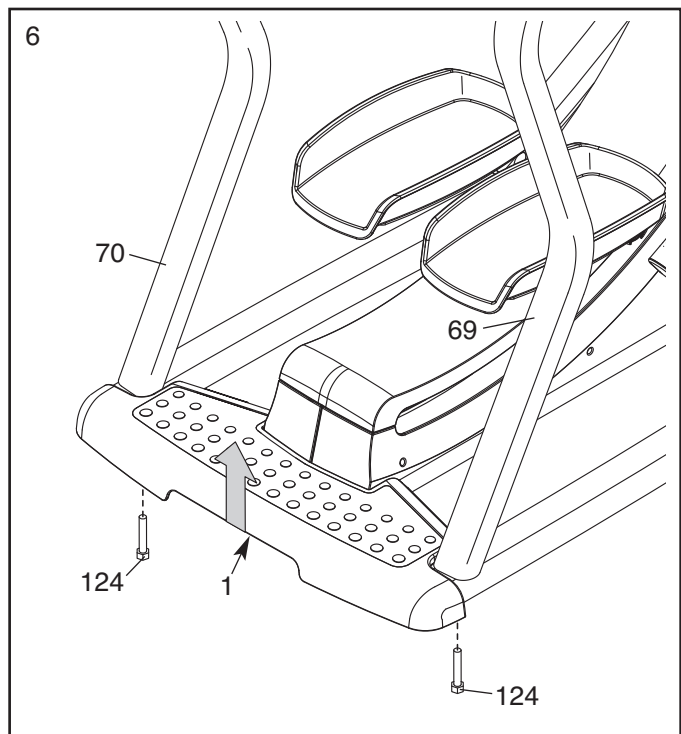

7. While another person holds the Console (4) near the Upright (26), connect the console wires to the Wire Harness (77), the Power Cable (81), and the Ground Wire (82). Then, connect the console pulse wires to the Pulse Wires (78).

Insert the excess wire downward into the Upright (26).

**Tip: Avoid pinching the wires.** Attach the Console (4) to the Upright (26) with four 1/4" x 3/4" Patch Screws (127).

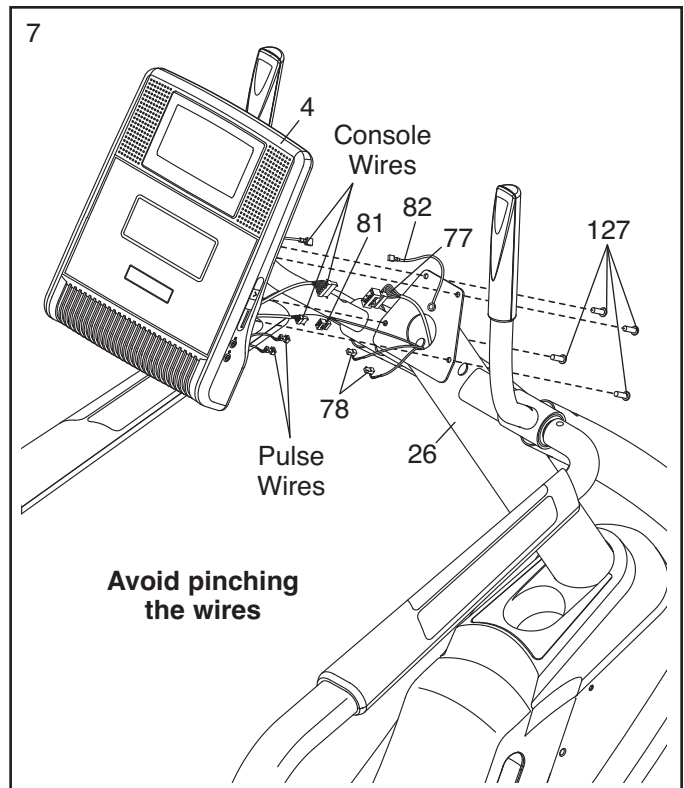

8. Identify the Front and Rear Shields (10, 13) and orient them as shown.

Attach the Front and Rear Shields (10, 13) around the Upright (26) with six #8 x 3/4" Screws (86).

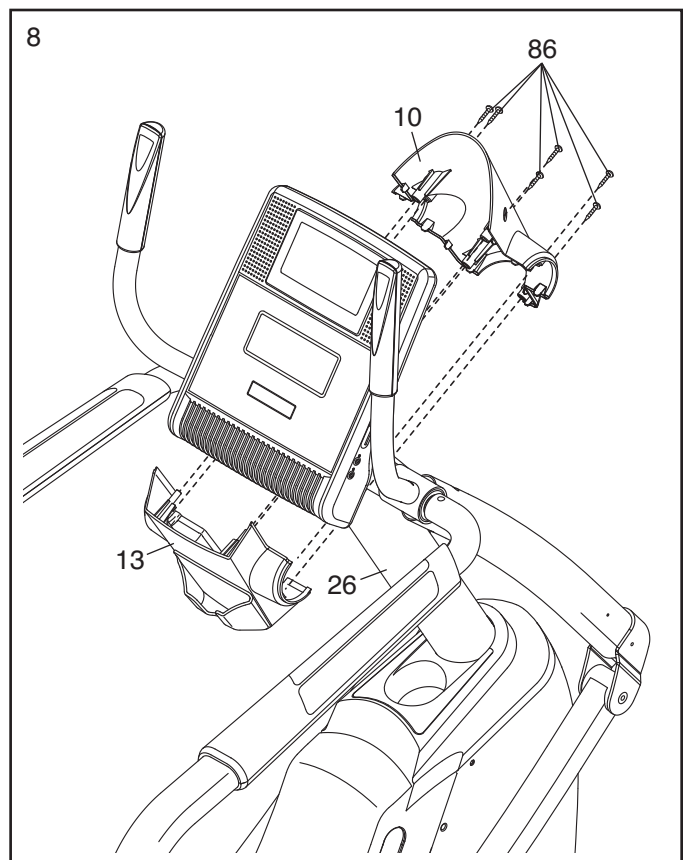

9. Identify the Right Upper and Lower Covers (14, 15), which are marked with “Right” stickers, and orient them as shown.

Attach the Right Upper and Lower Covers (14, 15) around the Right Handlebar (20) with two #8 x 3/4" Screws (86).

**Repeat this step for the Left Handlebar (21).**

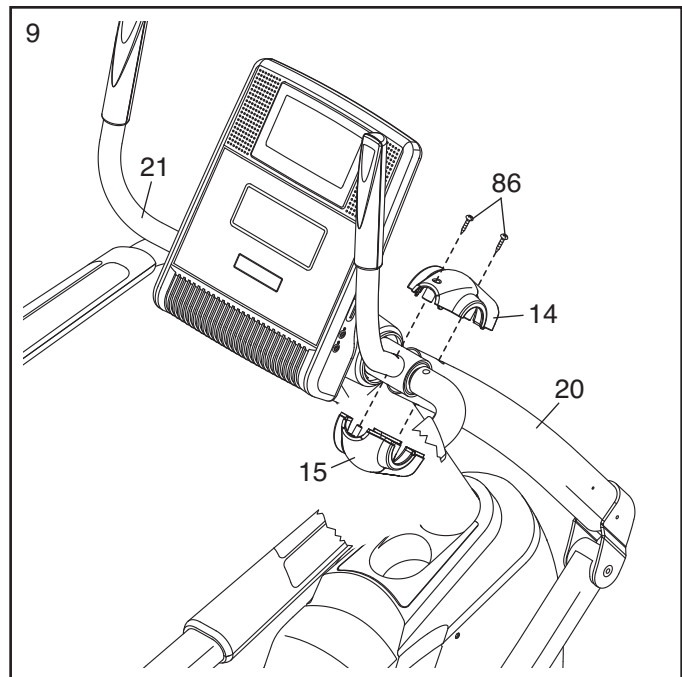

10. Identify a set of Right and Left Link Covers (22, 23), which are marked with “Right” and “Left” stickers, and orient them as shown.

Attach the Right and Left Link Covers (22, 23) around the Right Handlebar (20) with four #8 x 1" Tek Screws (126).

**Repeat this step for the other side of the elliptical strider.**

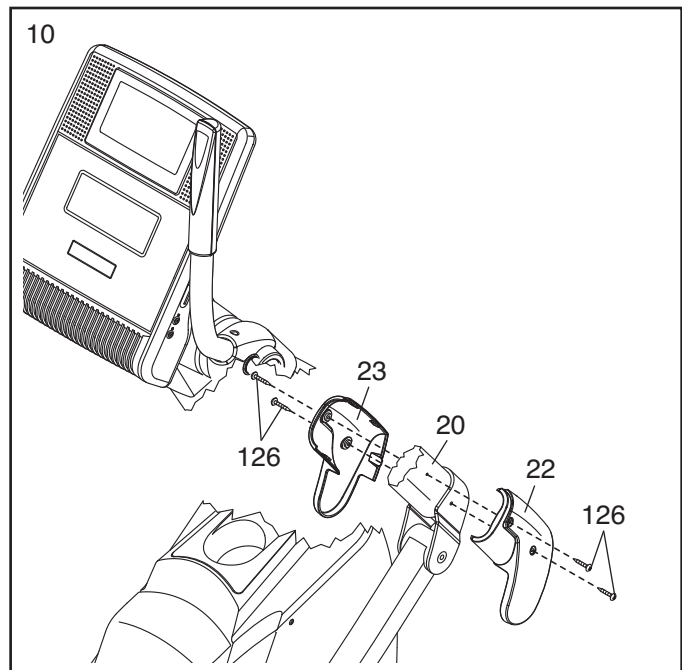

11. Plug the AC power adapter into the jack on the front of the elliptical strider; then, plug the power cord into the AC power adapter (see HOW TO PLUG IN THE AC POWER ADAPTER AND THE POWER CORD on page 14). **IMPORTANT: If the elliptical strider has been exposed to cold temperatures, allow it to warm to room temperature before plugging in the AC power adapter and the power cord. If you do not do this, you may damage the console displays or other electronic components.**

**Make sure that all parts are properly tightened before you use the elliptical strider.** Note: After assembly is completed, some extra parts may be left over. Place a mat beneath the elliptical strider to protect the floor.

# HOW TO CONNECT THE PERSONAL TELEVISION

Before operating the television, you must connect an antenna or a 75 ohm CATV cable to the 75 ohm terminal or the audio/video component cable to the audio/video input jack. Note: Use a CATV cable to connect to an external source such as a cable box, satellite TV box, VCR, or analog cable. No CATV cable, antenna, or adapter is included.

## HOW TO CONNECT AN ANTENNA

Place an indoor VHF antenna or an outdoor combination VHF/UHF antenna in the desired location. Outdoor antennas are subject to weathering that can reduce signal quality. Inspect your outdoor antenna and the lead-in wiring before connecting the antenna.

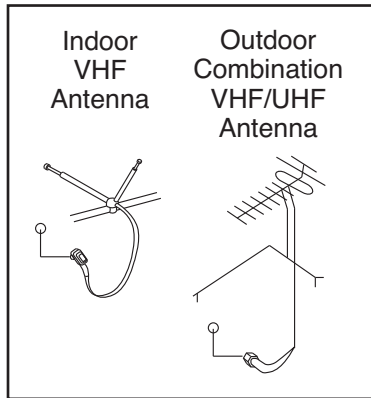

Note: Due to an FCC requirement, analog signals will no longer be broadcast over the air after February 17, 2009. If you wish to view television signals through an antenna after that date, you must have an antenna capable of receiving digital signals. Cable television will not be affected.

## HOW TO CONNECT AN EXTERNAL SOURCE USING A CATV CABLE

1. Connect one end of a 75 ohm CATV cable to the 75 ohm output jack on your external source.
2. Plug in the power cord of your external source. See your external source user's manual for proper grounding instructions.
3. Connect the 75 ohm CATV cable to the 75 ohm terminal located on the elliptical strider frame near the power cord. See the drawing at the left.

## 75 Ohm CATV Cable

1. Connect the 75 ohm CATV cable from the antenna to the 75 ohm terminal located on the elliptical strider frame near the power cord.

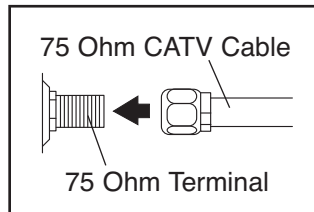

## HOW TO CONNECT A VCR OR DVD PLAYER USING THE AUDIO/VIDEO COMPONENT CABLE

1. Connect the three-pronged end of the included audio/video component cable to your VCR or DVD player.

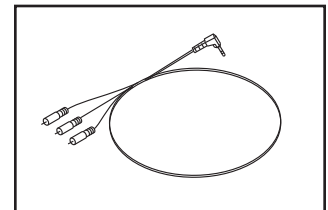

2. Plug in the power cord of your VCR or DVD player. See your VCR or DVD player user's manual for proper grounding instructions.
3. Connect the audio/video component cable to the audio/video input jack located on the elliptical strider frame near the power cord.

## 300 Ohm Flat Wire

1. Connect the 300 ohm flat wire from the antenna to a 300 ohm to 75 ohm adapter.

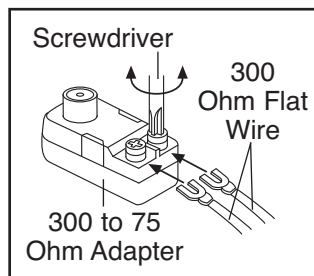

2. Push the 300 ohm to 75 ohm adapter onto the 75 ohm terminal located on the elliptical strider frame near the power cord.

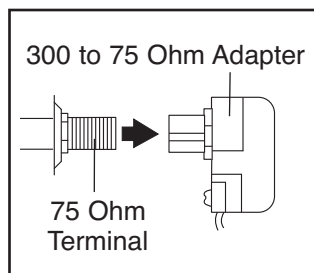

# HOW TO USE THE CHEST PULSE SENSOR

## HOW TO PUT ON THE CHEST PULSE SENSOR

The chest pulse sensor has two components: a chest strap and a sensor unit (see the drawing below). Insert the tab on one end of the chest strap into one end of the sensor unit, as shown in the inset drawing. Press the end of the sensor unit under the buckle on the chest strap. The tab should be flush with the front of the sensor unit.

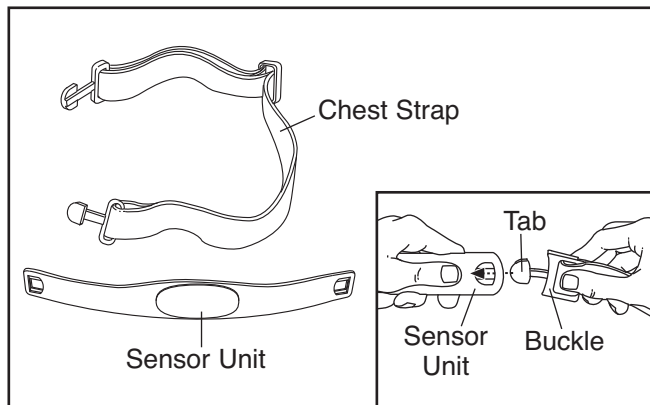

Next, wrap the chest pulse sensor around your chest and attach the other end of the chest strap to the sensor unit. Adjust the length of the

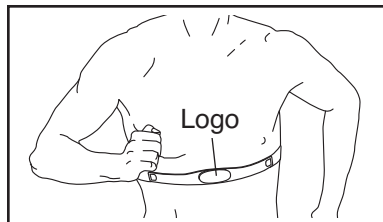

chest strap, if necessary. The chest pulse sensor should be under your clothes, tight against your skin, and as high under the pectoral muscles or breasts as is comfortable. Make sure that the logo on the sensor unit is facing forward and is right-side-up.

Pull the sensor unit away from your body a few inches and locate the two electrode areas on the inner side (the electrode areas are covered by shallow ridges). Using saline solution such as saliva or contact lens solution, wet both electrode areas. Return the sensor unit to a position against your chest.

## CHEST PULSE SENSOR CARE

- Dry the chest pulse sensor after each use. The chest pulse sensor is activated when you wet the electrode areas and put on the chest pulse sensor; the chest pulse sensor shuts off when it is removed and the electrode areas are dried. If the chest pulse sensor is not dried after each use, the battery may be drained prematurely.

- Store the chest pulse sensor in a warm, dry place. Do not store the chest pulse sensor in a plastic bag or other container that may trap moisture.
- Do not expose the chest pulse sensor to direct sunlight for extended periods of time or to temperatures above 122° F (50° C) or below 14° F (-10° C).
- Do not excessively bend or stretch the sensor unit when using or storing the chest pulse sensor.
- Clean the sensor unit using a damp cloth—never use alcohol, abrasives, or chemicals. Hand wash and air dry the chest pulse sensor.

## CHEST PULSE SENSOR TROUBLESHOOTING

**If the chest pulse sensor does not function properly, try the steps below.**

- Make sure that you are wearing the chest pulse sensor as described at the left. Note: If the chest pulse sensor does not function when positioned as described, move it slightly lower or higher.
- Use saline solution such as saliva or contact lens solution to wet the two electrode areas on the sensor unit. If heart rate readings do not appear until you begin perspiring, re-wet the electrode areas.
- Position yourself near the console. **For the console to display heart rate readings, the user must be within arm's length of the console.**
- The chest pulse sensor is designed to work with people who have normal heart rhythms. Heart rate reading problems may be caused by medical conditions such as premature ventricular contractions (pvc's), tachycardia bursts, and arrhythmia.
- The operation of the chest pulse sensor can be affected by magnetic interference caused by high power lines or other sources. If it is suspected that this is a problem, try relocating the elliptical strider.

# HOW TO USE THE ELLIPTICAL STRIDER

## HOW TO PLUG IN THE AC POWER ADAPTER AND THE POWER CORD

This product **must be grounded**. If it should malfunction or break down, grounding provides a path of least resistance for electric current to reduce the risk of electric shock.

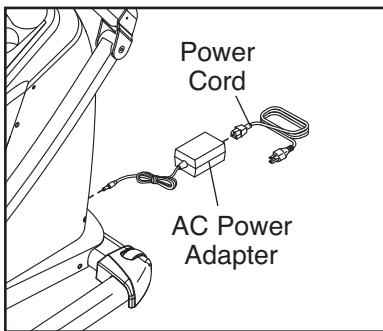

This product is equipped with a cord having an equipment-grounding conductor and a grounding plug. **Plug the AC power adapter into the jack on the front of the elliptical strider and into the power cord. Then, plug the power cord into an appropriate outlet that is properly installed and grounded in accordance with all local codes and ordinances. This product is for use on a nominal 120-volt circuit. IMPORTANT: The elliptical strider is not compatible with GFCI-equipped outlets.**

**⚠ DANGER:** Improper connection of the equipment-grounding conductor can result in an increased risk of electric shock. Check with a qualified electrician or serviceman if you are in doubt as to whether the product is properly grounded. Do not modify the plug provided with the product—if it will not fit the outlet, have a proper outlet installed by a qualified electrician.

A temporary adapter may be used to connect the power cord to a 2-pole receptacle as shown at the right if a properly grounded outlet is not available. The temporary adapter should be used only until a properly grounded outlet can be installed by a qualified electrician.

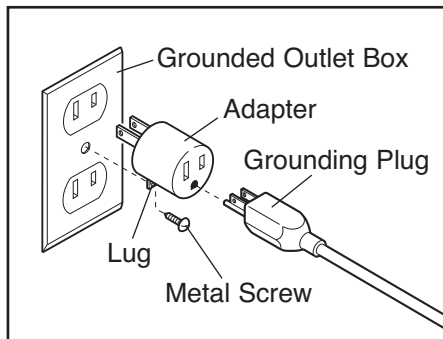

The green-colored rigid ear, lug, or the like extending from the adapter must be connected to a permanent ground such as a properly grounded outlet box cover. Whenever the adapter is used, it must be held in place by a metal screw. **Some 2-pole receptacle outlet box covers are not grounded. Contact a qualified electrician to determine if the outlet box cover is grounded before using an adapter.**

## HOW TO MOVE THE ELLIPTICAL STRIDER

**Due to the size and weight of the elliptical strider, moving it requires two persons.** Have two persons lift the indicated end of the elliptical strider until the elliptical strider will roll on the front wheels. Carefully move the elliptical strider to the desired location and then lower it to the level position. **CAUTION: To decrease the risk of injury, bend your legs and keep your back straight. Make sure to use your legs rather than your back to lift the elliptical strider. Do not attempt to move the elliptical strider over an uneven surface.**

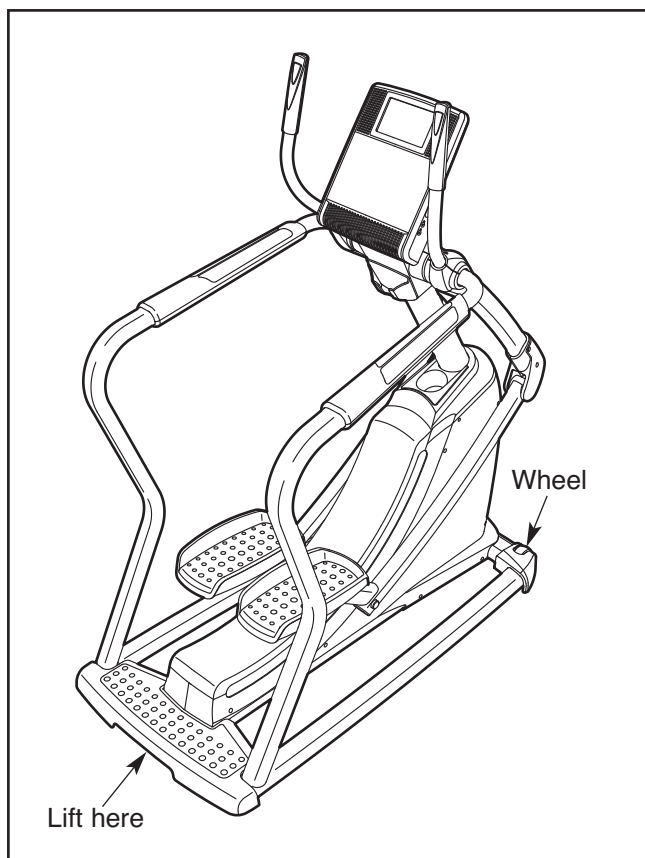



## HOW TO EXERCISE ON THE ELLIPTICAL STRIDER

To mount the elliptical strider, hold the handlebars or the handrails and step onto the pedals. Push the pedals until they begin to move forward and backward with a continuous motion.

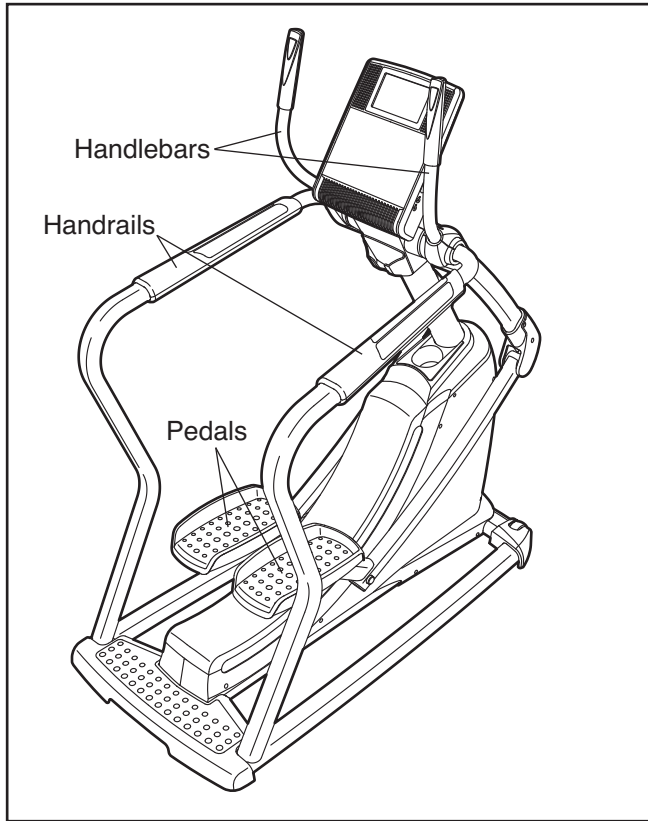

To dismount the elliptical strider, wait until the pedals come to a complete stop. When the pedals are stationary, hold the handlebars or the handrails and step off the pedals.

## HOW TO LEVEL THE ELLIPTICAL STRIDER

If the elliptical strider rocks slightly on your floor during use, turn one or both of the leveling feet beneath the rear of the frame until the rocking motion is eliminated.

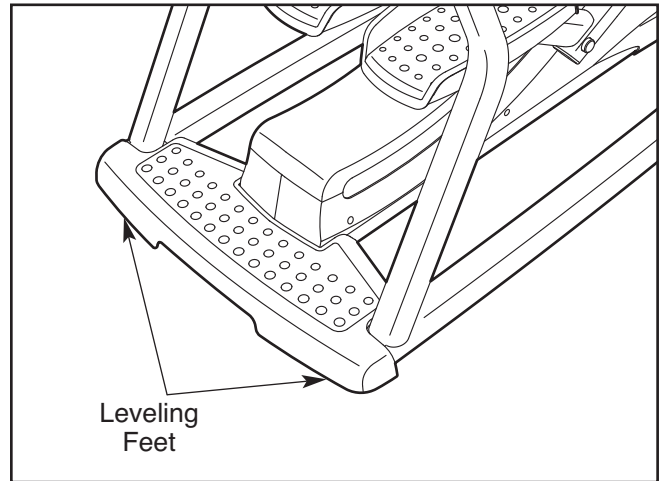

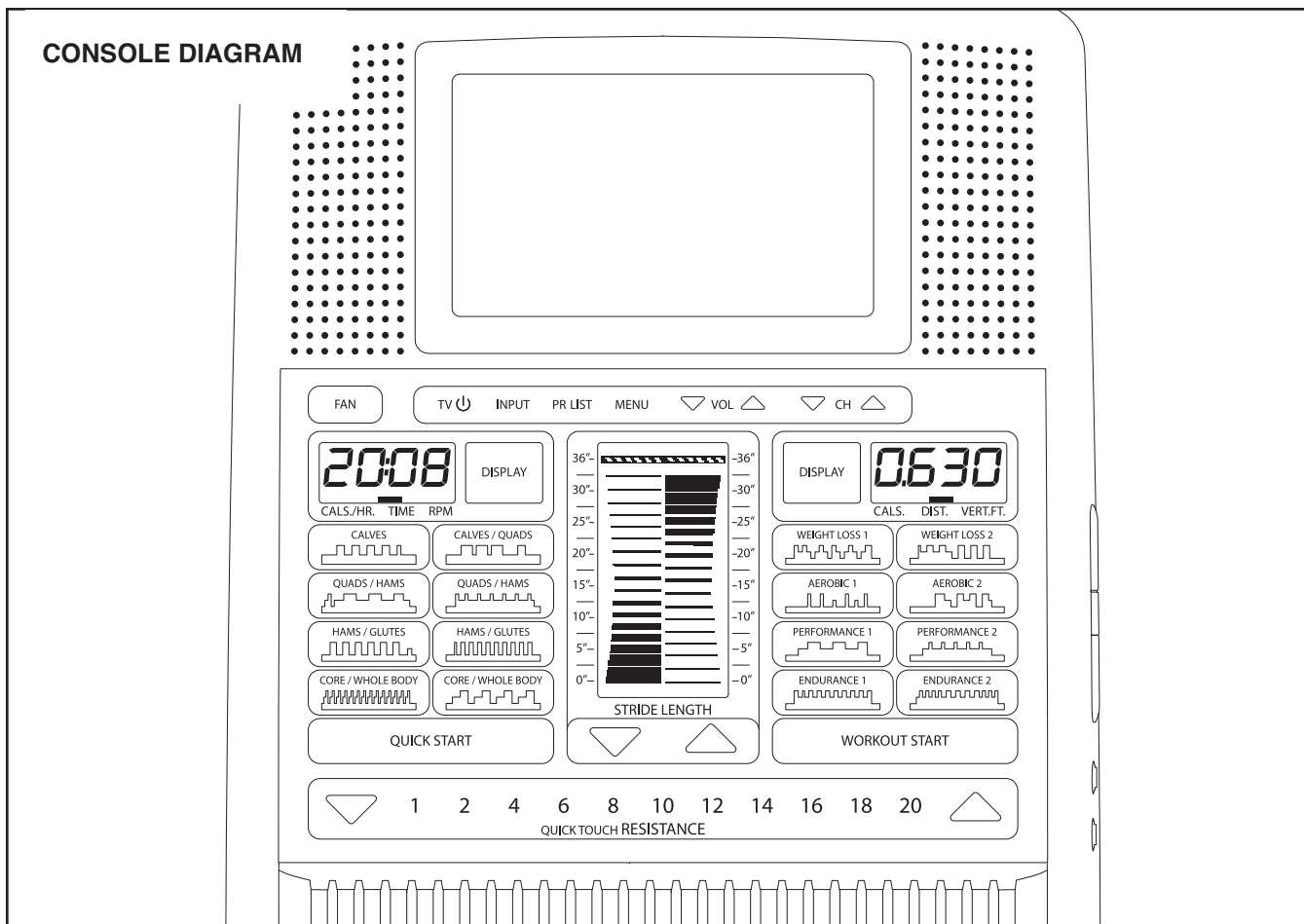

## FEATURES OF THE CONSOLE

The advanced console offers an array of features designed to make your workouts effective and enjoyable. When you use the quick start mode of the console, you can change the resistance of the pedals or set a target stride length with the touch of a button. As you exercise, the console will provide continuous exercise feedback. You can even measure your heart rate using the handgrip pulse sensor or the included chest pulse sensor.

The console offers sixteen preset workouts. Each workout automatically changes the resistance of the pedals and prompts you to maintain a target stride length as it guides you through an effective workout.

The console features the iFit Interactive Workout System, which enables the console to accept iFit cards containing workouts designed to help you achieve specific fitness goals. For example, lose unwanted pounds with the 8-week Weight Loss workout. iFit workouts control the resistance of the pedals

while the voice of a personal trainer coaches you through your workouts. iFit cards are available separately. **To purchase iFit cards, go to [www.iFit.com](http://www.iFit.com) or see the back cover of this manual. iFit cards are also available at select stores.**

Whether you select the manual mode or a workout, you can enjoy the shows of your choice on the personal television while you get in shape. You can also connect your MP3 player or CD player to the console's sound system and listen to your favorite workout music or audio books while you exercise.

**To activate the console, see page 17. To turn off the console, see page 17. To use the quick start mode, see page 17. To use a preset workout, see page 19. To use an iFit workout, see page 20. To use the sound system, see page 21. To operate the personal television, see page 21. To use the remote control, see page 22. To adjust television settings, see page 23. To use the maintenance mode, see page 25.**



## HOW TO ACTIVATE THE CONSOLE

The included AC power adapter and the power cord must be used to operate the elliptical strider. See HOW TO PLUG IN THE AC POWER ADAPTER AND THE POWER CORD on page 14. When the AC power adapter and the power cord are plugged in, the displays will light and the console will be ready for use.

**IMPORTANT: If the console has been exposed to cold temperatures, allow it to warm to room temperature before activating the console. Otherwise, you may damage the console displays or other electronic components.**

## HOW TO TURN OFF THE CONSOLE

If the pedals are not moved for a short period of time, the console will enter an idle mode and a screen saver will appear in the center display. Unplug the AC power adapter and the power cord when the elliptical strider is not in use.

## HOW TO USE THE QUICK START MODE

The quick start mode allows you to start exercising, adjust the resistance of the pedals manually, and set a target stride length manually.

### 1. Activate the console.

Press the QUICK START button or begin striding to activate the console.

See HOW TO ACTIVATE THE CONSOLE above.

### 2. Select the quick start mode.

When you activate the console, the quick start mode will be selected. If you have selected a workout, reselect the quick start mode by pressing any of the workout buttons repeatedly until zeros appear in the left and right displays.



### 3. Change the resistance of the pedals as desired.

As you stride, change the resistance of the pedals by pressing one of the numbered QUICKTOUCH RESISTANCE buttons or by pressing the QUICK-

TOUCH RESISTANCE increase and decrease buttons. Note: After you press a QUICKTOUCH RESISTANCE button, it will take a moment for the pedals to reach the selected resistance level.

You can also adjust the resistance level by pressing the increase and decrease buttons on the handlebars.

### 4. Set a target stride length as desired.

The stride length meter in the center display allows you to set a target stride length.

To set a target stride length, press the STRIDE LENGTH increase and decrease buttons located below the stride length meter repeatedly until the target bar appears next to the desired stride length. Note: Stride length is measured in inches.

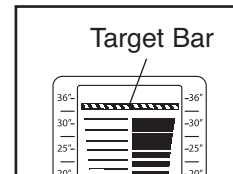

### 5. Follow your progress with the displays.

**Left display**—This display will show the approximate number of calories you are burning per hour, the elapsed time, and your striding pace in revolutions per minute (rpm), for a few seconds each, in a repeating scan cycle. An indicator will show which information is currently displayed.

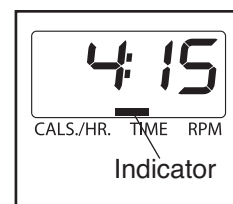

To select the approximate number of calories you are burning per hour, the elapsed time, or your striding pace for continuous display, press the left Display button repeatedly until an indicator appears above the information you are interested in viewing.

To reselect the scan cycle, press the left Display button repeatedly until the word SCAN appears in the left display.



Note: When you select a workout, the display will show the time remaining in the workout instead of the elapsed time.

**Center display**—This display shows the stride length meter. The stride length meter compares your actual stride length to the target stride length.

The target bar in the stride length meter indicates the target stride length. The pedal blocks track the actual movement of the pedals while you exercise.

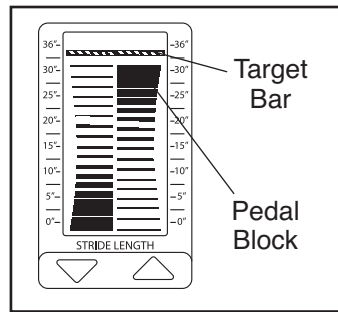

As you exercise, keep your stride length near the target stride length by striding so that the pedal blocks move back and forth between the bottom of the display and the target bar.

The center display will also show the resistance level of the pedals for a few seconds each time the resistance level changes. In addition, the center display will show your heart rate when you use the handgrip pulse sensor (see step 6 at the right) or the included chest pulse sensor (see page 13).

**Right display**—This display will show the approximate number of calories you have burned, the distance (total number of miles) you have stridden, and the distance (vertical feet) you have climbed, for a few seconds each, in a repeating scan cycle. An indicator will show which information is currently displayed.

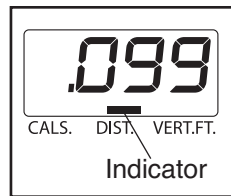

To select the approximate number of calories you have burned, the distance you have stridden, or the distance you have climbed for continuous display, press the right Display button repeatedly until an indicator appears above the information you are interested in viewing.

To reselect the scan cycle, press the right Display button repeatedly until the word SCAN appears in the right display.



To adjust the volume level of the console, press the VOL increase and decrease buttons.

## 6. Measure your heart rate if desired.

To use the included chest pulse sensor, see page 13. To use the handgrip pulse sensor, follow the instructions below. **Note: If you wear the chest pulse sensor and hold the handgrip pulse sensor at the same time, the console will not display your heart rate accurately.**

**If there are sheets of clear plastic on the metal contacts on the handgrip pulse sensor, remove the plastic. In addition, make sure that your hands are clean.** To measure your heart rate, hold the handgrip pulse sensor with your palms resting against the metal contacts. **Avoid moving your hands or gripping the contacts tightly.**

When you hold the handgrip pulse sensor, the word PULSE and a set of flashing dashes will appear in the center display. Then, when your pulse is detected, your heart rate will be shown in the center display. For the most accurate heart rate reading, hold the contacts for at least 15 seconds.

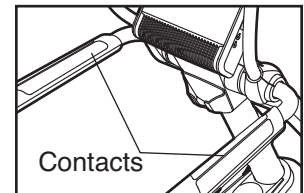

If your heart rate is not shown, make sure that your hands are positioned as described. Be careful not to move your hands excessively or to squeeze the metal contacts tightly. For optimal performance, clean the metal contacts using a soft cloth; **never use alcohol, abrasives, or chemicals to clean the contacts.**

## 7. Turn on the fan if desired.

The fan has high and low speed settings. Press the FAN button repeatedly to select a fan speed or to turn off the fan. Note: If the pedals do not move for about thirty seconds, the fan will turn off automatically.

## 8. When you are finished using the elliptical strider, the console will automatically enter an idle mode.

See HOW TO TURN OFF THE CONSOLE on page 17.

## HOW TO USE A PRESET WORKOUT

A preset workout automatically changes the resistance of the pedals and prompts you to maintain a target stride length.

### 1. Press any button or begin striding to activate the console.

See HOW TO ACTIVATE THE CONSOLE on page 17.

### 2. Select a preset workout.

To select a preset workout, press the workout button with the desired name and profile.

The following information will appear in the center display:

- The name of the workout
- A profile of the target stride lengths
- The duration of the workout
- The maximum stride length
- The maximum speed (in steps per minute)

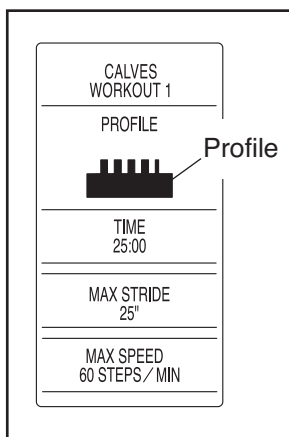

### 3. Start the workout.

Press the WORKOUT START button or begin striding to start the workout.

Each preset workout is divided into 25, 30, 45, or 60 one-minute segments. One resistance level and one stride length is programmed for each segment. Note: The same resistance level and/or stride length may be programmed for consecutive segments.

During the workout, the workout profile will show your progress (see the drawing at the left). The flashing column of the profile represents the current segment of the workout. The height of the flashing column indicates the stride length for the current segment. At the end of each segment of the workout, a series of tones will sound and the next segment of the profile will begin to flash. If a different resistance level is programmed for the next segment, the resistance level of the pedals will then change.

As you exercise, keep your stride length near the target stride length for the current segment, which is shown in the stride length meter in the center display. **IMPORTANT: The target stride length settings are intended only to provide motivation. Your actual stride length may be shorter or longer than the target stride length. Make sure to stride at a length that is comfortable for you.**

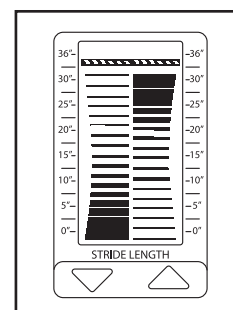

If the stride length for the current segment is too long or too short, you can manually override the setting by pressing the STRIDE LENGTH buttons. However, when the current segment ends, the stride length meter will automatically adjust to the target stride length for the next segment.

If the resistance level for the current segment is too high or too low, you can manually override the setting by pressing the QUICKTOUCH RESISTANCE buttons. However, when the current segment ends, the pedals will automatically adjust to the resistance level for the next segment.

The workout will continue in this way until the last segment of the profile flashes. To stop the workout at any time, stop striding. To resume the workout, simply resume striding or press the WORKOUT START BUTTON.

**4. Follow your progress with the displays.**

See step 5 on page 17.

**5. Measure your heart rate if desired.**

See step 6 on page 18.

**6. Turn on the fan if desired.**

See step 7 on page 18.

**7. When you are finished using the elliptical strider, the console will automatically enter an idle mode.**

See HOW TO TURN OFF THE CONSOLE on page 17.

## HOW TO USE AN IFIT WORKOUT

iFit cards are available separately. To purchase iFit cards, go to [www.iFit.com](http://www.iFit.com) or see the back cover of this manual. iFit cards are also available at select stores.

**1. Press any button or begin striding to activate the console.**

See HOW TO ACTIVATE THE CONSOLE on page 17.

**2. Insert an iFit card and select a workout.**

To use an iFit workout, insert an iFit card into the iFit slot, which is located on the right side of the console. The iFit card should slide easily into the slot. If it does not, turn the iFit card and try again.

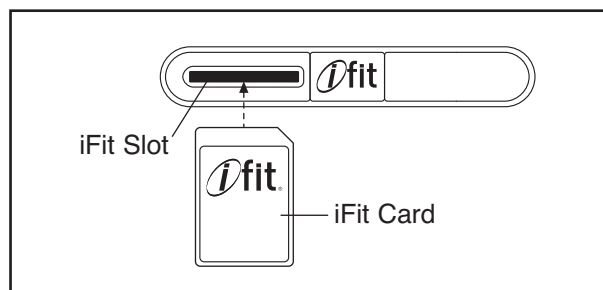

iFit workouts function in the same way as preset workouts. To use the workout, see steps 3 to 7 on pages 19–20.

Some iFit cards contain more than one workout. To select a workout, press the STRIDE LENGTH increase and decrease buttons.

During an iFit workout, press the STRIDE LENGTH increase and decrease buttons to adjust the volume level for the voice of the personal trainer.

**3. When you are finished exercising, remove the iFit card.**

Remove the iFit card when you are finished exercising. Store the iFit card in a secure place.

## HOW TO USE THE SOUND SYSTEM

To play music or audio books through the console's sound system while you exercise, plug the included audio cable into the MP3 jack on the right side of the console and into a jack on your MP3 player or CD player; **make sure that the audio cable is fully plugged in.**

Next, press the play button on your MP3 player or CD player. Press the VOL increase and decrease buttons on the console to adjust the volume level or use the volume control on your MP3 player or CD player.

You can use your own headphones with the console or with an iFit workout (see HOW TO USE AN IFIT WORKOUT on page 20). To use your headphones, plug your headphones cable into the headphone jack on the right side of the console; **make sure that the headphones cable is fully plugged in.**

## HOW TO OPERATE THE PERSONAL TELEVISION

**IMPORTANT: Before operating the television, you must connect the audio/video component cable or a CATV cable to the elliptical strider (see page 12).**

### 1. Turn on the television.

If there is a sheet of clear plastic on the television screen, remove the plastic. Press the Power button to turn on the television.

### 2. Scan for television channels.

Before operating your television, you must scan for channels. See page 24 for information on scanning for channels. Note: To use a VCR or DVD player, you must connect a VCR or DVD player and then scan for channels.

Your television can receive analog and digital signals. For the television to operate properly, good reception is necessary. Make sure the television settings are set correctly (see HOW TO ADJUST THE TELEVISION SETTINGS on page 23). If you are using an antenna, make sure that it is properly connected and adjusted for optimal reception (see HOW TO CONNECT AN ANTENNA on page 12).

### 3. Select a television source.

Press the INPUT button repeatedly to select a television source.

If you have connected an antenna or a 75 ohm CATV cable to the 75 ohm terminal on the elliptical strider, select the TV source. If you have plugged the audio/video component cable into the audio/video input jack, select the AV source.

To use a VCR or DVD player, make sure that the VCR or DVD player is connected correctly (see page 12). Select the AV source and press play on your VCR or DVD player.

### 4. Select the desired channel.

When you turn on the television, the screen will show the last channel that was selected. To select a different channel, press the numbered channel buttons on the remote or the Channel increase and decrease buttons on the console. The selected channel number will appear on the screen for a few seconds. Note: Before channels can be selected, they must be saved in the television's memory (see page 24).

### 5. Adjust the volume level.

Press the Volume increase or decrease buttons on the console to change the volume level. Note: For best results, change the volume by pressing the Volume buttons on the console only. Make sure that the audio cable is not plugged into the audio jack on the console.

To use earphones or headphones (not included), plug them into the headphone jack located on the right side of the console.

### 6. Turn off the television.

When you are finished using the television, press the TV power button to turn off the television.

## HOW TO USE THE REMOTE CONTROL

The first time you use the remote control, insert batteries (see HOW TO REPLACE THE BATTERIES IN THE REMOTE CONTROL at the right).

Next, stand on the elliptical strider and hold the remote control near the television. Point the remote control directly at the television.

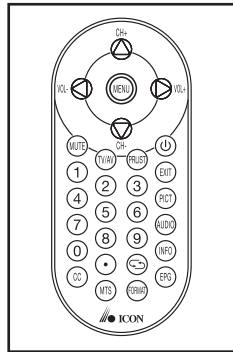

Press the Power button (⏻). After a few moments, the television will turn on or turn off.

Press the Volume (VOL) increase or decrease button to navigate left or right in a menu. For best results, change the volume by pressing the Volume buttons on the console only.

Press the Mute button to turn on or turn off the sound.

Press the numbered channel buttons or the Channel (CH) increase or decrease button to select a channel. The Channel increase and decrease buttons on the remote also function as the up and down navigation buttons in a menu.

Press the Return button (↵) to view the previously selected channel.

To select a subchannel, first select a channel, press the Subchannel button (\*), and then press the numbered channel buttons.

Press the MENU button to view the main menu or to view a previous menu. See pages 23 and 24 for information on the menu.

Press the EXIT button to exit any menu.

Press the PRLIST button to view a list of channels. If you have labeled any channels, the menu will also show the channel label. See page 24 for information on labeling channels. Note: You can also view this list by pressing the PR LIST button on the console.

Press the EPG button to view the electronic program guide. Note: The electronic program guide is only available when viewing ATSC digital television.

Press the INFO button to view information about the current program and the broadcast or cable signal.

Press the CC button repeatedly to turn on or turn off closed captioning. See step 5 on page 23 to adjust closed captioning settings.

Press the TV/AV button repeatedly to select the input source. To view television channels through an antenna or a CATV cable, select the TV source. To use the audio/video component cable, select the AV source.

Press the MTS button repeatedly to select mono, stereo, or SAP (secondary audio programming) as the audio setting.

Press the FORMAT button repeatedly to select auto, 4:3, or wide image as the display format. Note: The auto display format is only available when viewing ATSC digital television.

Press the PICT button repeatedly to select standard, dynamic, soft, or personal as the image mode.

Press the AUDIO button repeatedly to select standard, music, movie, or personal as the audio mode.

## HOW TO REPLACE THE BATTERIES IN THE REMOTE CONTROL

To replace the batteries, first locate the battery cover on the back of the remote control. Push down lightly on the battery cover with your thumb and slide off the battery cover.

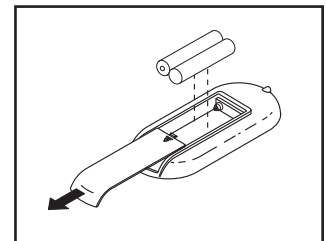

Next, remove the old batteries from the remote control, and insert two new AAA batteries. **Make sure to orient the batteries as shown in the drawing.** Then, slide the battery cover onto the remote control.



## HOW TO ADJUST THE TELEVISION SETTINGS

You must use your remote control to adjust television settings. Press the MENU button on the remote to enter the main menu or to return to a previous menu. Press the EXIT button to exit a menu. Press the Channel (CH) increase and decrease buttons to navigate up and down in a menu and the Volume (VOL) increase and decrease buttons on your remote control to navigate right and left.

### 1. Enter the main menu.

Press the MENU button to enter the main menu.

To select one of the icons across the top of the screen, press the Volume increase and decrease buttons on your remote control until the desired icon appears larger than the others. Select the monitor to adjust the image settings. Select the speaker to adjust the audio settings. Select the clock to adjust the time settings. Select the gear to adjust the television settings. Select the antenna to locate and save channels. To return to the main menu, press the Menu button repeatedly. Note: You can also press the MENU button on the console to enter the main menu.

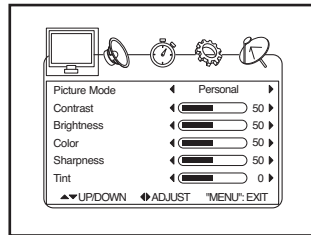

### 2. Adjust the image settings.

Select the personal, standard, dynamic, or soft picture mode. The contrast, brightness, color, sharpness, and tint will automatically adjust. You can also manually adjust the contrast, brightness, color, sharpness, or tint.

### 3. Adjust the audio settings.

Select the personal, standard, movie, or music sound mode. The bass, treble, and balance will automatically adjust. You can also manually adjust the bass, treble, balance, or audio language.

Select an audio language to hear programs in the selected language. Note: The audio language setting will function only if another audio signal is available.

### 4. Adjust the time settings.

Adjust the OSD (on-screen display) duration, sleep timer, time zone, or daylight savings time settings. The clock will display the current date and time and is reset every time the power is turned on. The OSD duration is the length of time indicators (like channel number or the electronic program guide) will remain on the screen after they appear. If you set the sleep timer, the television will turn off after the indicated number of minutes. A count-down will warn you when the television is about to turn off. Note: The time zone setting, daylight savings time setting, and clock are only available when viewing digital television.

### 5. Adjust the television settings.

Adjust the language used in the menus, the transparency of the menu, the color mode, or the closed caption settings. You can also restore the original television settings.

To enter the closed caption submenu, highlight CLOSED CAPTION and press the Volume increase button on your remote control. In the closed caption submenu, adjust the closed caption mode, the basic selection, and the advanced selection.

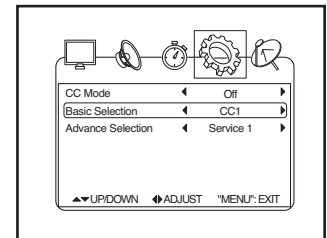

When you highlight RESTORE SETTING and press the Volume increase button, a confirmation request will appear in the display. Use the Volume increase or decrease button to select YES or NO and press the Channel increase or decrease button to confirm your selection. Select YES to restore the original television settings or NO to keep the current settings.

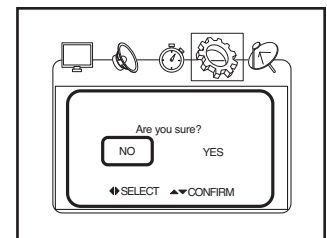

## 6. Scan and save channels.

Select CATV or AIR. Select CATV to receive channels through the 75 ohm terminal on the elliptical strider. Select AIR to receive channels through an antenna.

To scan for available channels, highlight AUTO SCAN or AUTO SCAN ADD CH. To scan all channels, select the Auto scan option. To scan all channels and add an extra channel, select the Auto Scan Add Ch option. The scan channel submenu will appear.

If you are receiving channels through a CATV cable, highlight CABLE SYSTEM and select the auto, STD, IRC, or HRC setting. Try all four cable settings, if necessary, to find the optimal setting.

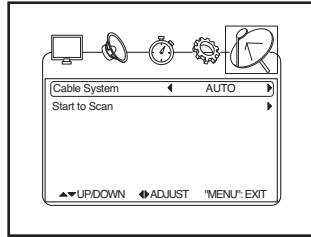

Highlight START TO SCAN and press the Volume increase button to start the auto scan. The television will begin scanning all of the channels available in your area. When no signal is detected on a channel, the channel will be skipped. When a signal is detected, the channel will be saved into memory and the next channel will be selected. This process will continue until the highest channel number is reached. The television will renumber the channels in the order in which it locates them. **Do not press any buttons on the remote or on the console while the television is scanning channels.** Note: If a television channel disappears, scan for channels again.

After all valid channels available in your area have been saved into the television's memory, you can manually skip unwanted channels.

To skip a channel, highlight CHANNEL

SKIP and press the Volume increase button on your remote control. In the channel skip submenu, press the Channel increase and decrease buttons to highlight the desired channel and press the Volume increase and decrease buttons to turn on or turn off the skip option. Continue this process until you have skipped all unwanted channels.

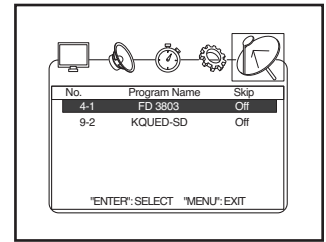

To change the display name of a channel, highlight CHANNEL NO. and select a channel. Then, highlight CHANNEL LABEL and press the

Volume increase button to enter the channel label submenu. Press the Volume increase and decrease buttons to select a number or letter box. Then press the Channel increase and decrease buttons to select the desired number or letter.

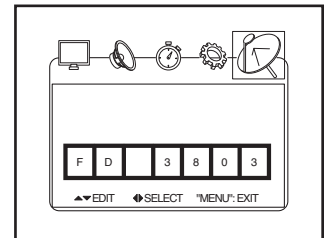

## 7. Exit the Menu.

When you have finished adjusting the settings, press the EXIT button.



## HOW TO USE THE MAINTENANCE MODE

The console features a maintenance mode that allows you to access usage information and to view and change console settings.

### 1. Press any button or begin striding to activate the console.

See HOW TO ACTIVATE THE CONSOLE on page 17.

### 2. Select the maintenance mode.

Hold down the FAN button for a few seconds to select the maintenance mode.

When the maintenance mode is selected, usage information for the elliptical strider will appear in the center display.

### 3. View and reset the usage information if desired.

The first section of the center display will show the total number of hours that the elliptical strider has been used, the total number of vertical feet that the pedals have climbed, and the total distance that the pedals have been moved.

To reset the usage information to zero, press and hold down the Resistance increase and decrease buttons simultaneously for several seconds.

### 4. Adjust the contrast level of the console displays if desired.

To adjust the contrast level of the console displays, press the STRIDE LENGTH increase and decrease buttons until the console displays show the desired contrast.

### 5. Exit the maintenance mode.

Press the QUICK START or the WORKOUT START button to exit the maintenance mode.

---

# MAINTENANCE AND TROUBLESHOOTING

**If you have questions about maintenance or troubleshooting, see the back cover of this manual.**

Inspect and tighten all parts of the elliptical strider regularly. Replace any worn parts immediately.

To clean the elliptical strider, use a damp cloth and a small amount of mild soap. Make sure to regularly clean the track rollers and the track frame on which the track rollers ride. **IMPORTANT: To avoid damage to the console, keep liquids away from the console and keep the console out of direct sunlight.**

## HOW TO LEVEL THE ELLIPTICAL STRIDER

If the elliptical strider rocks slightly on your floor during use, see HOW TO LEVEL THE ELLIPTICAL STRIDER on page 15.

**Most television problems can be solved by following the steps below. Find the symptom that applies, and follow the steps listed. If further assistance is needed, please see the back cover of this manual.**

**PROBLEM: The remote control does not function correctly**

**SOLUTION:** a. Make sure you are standing on the elliptical exerciser, holding the remote control near the television and pointing the remote control directly at the console.

b. If your remote control is still not functioning correctly, the batteries should be replaced; most remote control problems are the result of low batteries. See page 22 to replace the batteries.

**PROBLEM: The television is not receiving a signal**

**SOLUTION:** a. Make sure the correct TV or AV source is selected. See step 3 on page 21 to select a television source.

b. Make sure that the antenna cable, CATV cable, or audio/video component cable is connected securely to the elliptical exerciser. See page 12 to connect a cable to the elliptical exerciser.

c. Scan for broadcast or cable signals. See page 24 to scan for signals.

d. Due to an FCC requirement, analog signals will no longer be broadcast over the air after February 17, 2009. If you wish to view television signals through an antenna after this date, you must have an antenna capable of receiving digital signals. Cable television will not be affected.

**PROBLEM: The volume is too loud or the television audio makes a crackling sound**

**SOLUTION:** a. If the television audio makes a crackling sound when the volume is turned up, the volume is too loud. Press the Volume increase or decrease button on the remote control until the volume level is 80 percent. Once the volume reaches 80 percent, adjust the volume by pressing the Volume buttons on the console only.

**PROBLEM: The volume cannot be turned up**

**SOLUTION:** a. If the volume cannot be turned up, the volume may have been adjusted with the remote control. Press the Volume increase or decrease button on the remote control until the volume level is 80 percent. Once the volume reaches 80 percent, adjust the volume by pressing the Volume buttons on the console only.

b. If there is no sound coming from the television, make sure the television audio is not muted.

c. If there is no sound coming from the television, make sure the audio wire is not plugged into the audio jack on the console.

**PROBLEM: The television needs to be cleaned**

**SOLUTION:** a. **UNPLUG THE POWER CORD.** To clean the television, wipe the television and screen using a soft cloth with a small amount of soft detergent. **Do not use a polishing cloth, solvent, or any type of propellant or chemical detergent such as alcohol or benzene.**

**PROBLEM: Television reception is poor**

**SOLUTION:** a. Make sure that the television settings are set correctly. See HOW TO ADJUST TELEVISION SETTINGS on page 23.

b. For the digital television to operate properly, good reception is necessary. If you are using an antenna, make sure that it is properly connected and adjusted for optimal reception. (See HOW TO CONNECT AN ANTENNA on page 12.)

c. Check for the problems listed below and follow the applicable instructions.

- Ignition (black spots or horizontal streaks that appear or a picture that flutters or drifts)— Usually this is caused by interference from automobile ignition systems, neon lamps, electric drifts, or other electric appliances. Try changing the position of the elliptical exerciser or other electric appliances to correct the problem.
- Ghosts—Ghosts are caused by the television signal following two paths—one is the direct path and the other is reflected from tall buildings, hills, or other objects. Change the direction or position of the antenna to improve reception.
- Blue Screen—If the elliptical exerciser is located in the fringe area of a television station where the signal is weak, the picture may be of poor quality or a blue screen may appear. If the signal is weak, it may be necessary to install an external antenna to improve the picture.
- Fading—If blocks of the picture are missing, the picture moves around the screen, or the picture disappears, the signal may be weak. Change the direction or position of the antenna to improve reception. Make sure the television settings are set correctly (see HOW TO ADJUST TELEVISION SETTINGS on page 23). Do not use a splitter.

Note: If one of these problems appears when the cable from a CATV company is connected, the problem may be caused by the cable company broadcast.

# EXERCISE GUIDELINES

**⚠ WARNING:** Before beginning this or any exercise program, consult your physician. This is especially important for persons over age 35 or persons with pre-existing health problems.

The pulse sensor is not a medical device. Various factors may affect the accuracy of heart rate readings. The pulse sensor is intended only as an exercise aid in determining heart rate trends in general.

These guidelines will help you to plan your exercise program. For detailed exercise information, obtain a reputable book or consult your physician. Remember, proper nutrition and adequate rest are essential for successful results.

## EXERCISE INTENSITY

Whether your goal is to burn fat or to strengthen your cardiovascular system, exercising at the proper intensity is the key to achieving results. You can use your heart rate as a guide to find the proper intensity level. The chart below shows recommended heart rates for fat burning and aerobic exercise.

165	155	145	140	130	125	115	♥
145	138	130	125	118	110	103	♥
125	120	115	110	105	95	90	♥
<hr/>							
20	30	40	50	60	70	80	

To find the proper intensity level, find your age at the bottom of the chart (ages are rounded off to the nearest ten years). The three numbers listed above your age define your “training zone.” The lowest number is the heart rate for fat burning, the middle number is the heart rate for maximum fat burning, and the highest number is the heart rate for aerobic exercise.

**Burning Fat**—To burn fat effectively, you must exercise at a low intensity level for a sustained period of time. During the first few minutes of exercise, your body uses *carbohydrate calories* for energy. Only after the first few minutes of exercise does your body begin to use stored *fat calories* for energy. If your goal is to burn fat, adjust the intensity of your exercise until your heart rate is near the lowest number in your training zone. For maximum fat burning, exercise with your heart rate near the middle number in your training zone.

**Aerobic Exercise**—If your goal is to strengthen your cardiovascular system, you must perform aerobic exercise, which is activity that requires large amounts of oxygen for prolonged periods of time. For aerobic exercise, adjust the intensity of your exercise until your heart rate is near the highest number in your training zone.

## WORKOUT GUIDELINES

**Warming Up**—Start with 5 to 10 minutes of stretching and light exercise. A warm-up increases your body temperature, heart rate, and circulation in preparation for exercise.

**Training Zone Exercise**—Exercise for 20 to 30 minutes with your heart rate in your training zone. (During the first few weeks of your exercise program, do not keep your heart rate in your training zone for longer than 20 minutes.) Breathe regularly and deeply as you exercise—never hold your breath.

**Cooling Down**—Finish with 5 to 10 minutes of stretching. Stretching increases the flexibility of your muscles and helps to prevent post-exercise problems.

## EXERCISE FREQUENCY

To maintain or improve your condition, complete three workouts each week, with at least one day of rest between workouts. After a few months of regular exercise, you may complete up to five workouts each week, if desired. Remember, the key to success is to make exercise a regular and enjoyable part of your everyday life.

## SUGGESTED STRETCHES

The correct form for several basic stretches is shown at the right. Move slowly as you stretch—never bounce.

### 1. Toe Touch Stretch

Stand with your knees bent slightly and slowly bend forward from your hips. Allow your back and shoulders to relax as you reach down toward your toes as far as possible. Hold for 15 counts, then relax. Repeat 3 times. Stretches: Hamstrings, back of knees and back.

### 2. Hamstring Stretch

Sit with one leg extended. Bring the sole of the opposite foot toward you and rest it against the inner thigh of your extended leg. Reach toward your toes as far as possible. Hold for 15 counts, then relax. Repeat 3 times for each leg. Stretches: Hamstrings, lower back and groin.

### 3. Calf/Achilles Stretch

With one leg in front of the other, reach forward and place your hands against a wall. Keep your back leg straight and your back foot flat on the floor. Bend your front leg, lean forward and move your hips toward the wall. Hold for 15 counts, then relax. Repeat 3 times for each leg. To cause further stretching of the achilles tendons, bend your back leg as well. Stretches: Calves, achilles tendons and ankles.

### 4. Quadriceps Stretch

With one hand against a wall for balance, reach back and grasp one foot with your other hand. Bring your heel as close to your buttocks as possible. Hold for 15 counts, then relax. Repeat 3 times for each leg. Stretches: Quadriceps and hip muscles.

### 5. Inner Thigh Stretch

Sit with the soles of your feet together and your knees outward. Pull your feet toward your groin area as far as possible. Hold for 15 counts, then relax. Repeat 3 times. Stretches: Quadriceps and hip muscles.

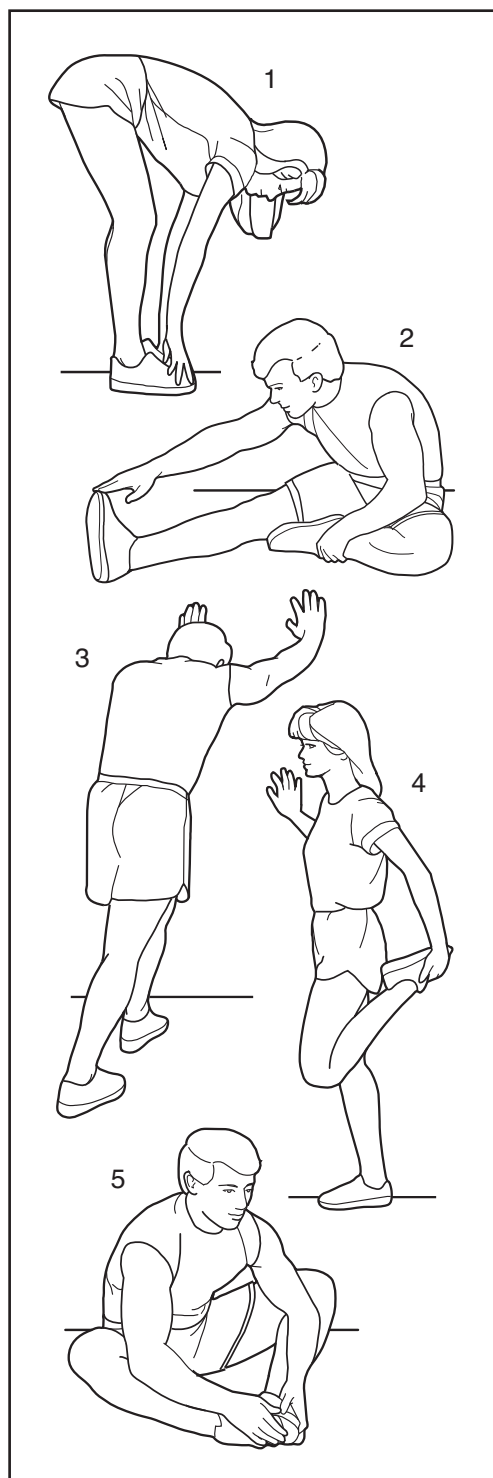

# PART LIST—Model No. SF8R82308.0

R1208A

Key No.	Qty.	Description	Key No.	Qty.	Description
1	1	Frame	51	1	Magnet Ring
2	2	Track	52	4	Small Pulley
3	2	Shield Bracket	53	1	Drive Belt Pulley
4	1	Console	54	2	Cable Spool
5	1	Shield Cap	55	1	Spool Hub
6	1	Right Shield	56	2	Spool Bearing
7	1	Left Shield	57	1	Magnet Ring Sensor
8	1	Right Frame Cover	58	2	Frame Bracket
9	1	Left Frame Cover	59	1	Spool Axle
10	1	Front Shield	60	2	Front Handgrip
11	1	Track Shield	61	1	Hub Key
12	1	Rear Frame Cover	62	2	Foot
13	1	Rear Shield	63	2	Leveling Foot
14	1	Right Upper Cover	64	1	Bumper
15	1	Right Lower Cover	65	1	Wiring Bracket
16	1	Left Upper Cover	66	2	Spool Cover
17	1	Left Lower Cover	67	2	Sensor Bracket
18	1	Accessory Tray	68	1	Cable Pulley Bracket
19	1	Drive Belt	69	1	Right Handrail
20	1	Right Handlebar	70	1	Left Handrail
21	1	Left Handlebar	71	2	Handrail Flange
22	2	Right Link Cover	72	2	Handrail Spacer
23	2	Left Link Cover	73	4	Handlebar Bearing
24	1	Right Pedal Arm	74	4	Wheel Spacer
25	1	Left Pedal Arm	75	2	Wheel
26	1	Upright	76	1	AC Power Adapter
27	2	Rear Handgrip	77	1	Wire Harness
28	2	Pedal	78	2	Pulse Wire
29	2	Pedal Insert	79	2	Sensor Wire
30	2	Pulse Sensor	80	1	Power Cord
31	2	Sensor Back	81	1	Power Cable
32	1	Left Cable Arm	82	1	Ground Wire
33	1	Right Cable Arm	83	4	Wheel Bearing
34	2	Upper Cable	84	4	Pulley Bearing
35	1	Lower Cable	85	1	Pedal Sensor
36	2	Pedal Leg Cap	86	43	#8 x 3/4" Screw
37	2	Roller Spacer	87	4	Link Bearing
38	2	Roller	88	1	5/16" x 1" Bolt
39	1	Flywheel	89	2	Link Axle
40	8	Cable Bushing	90	3	5/16" Locknut
41	1	Magnet Bracket	91	8	1/2" Snap Ring
42	1	Flywheel Hub	92	4	1 1/8" Snap Ring
43	2	Flywheel Bearing	93	7	#8 x 1/2" Flange Screw
44	1	Resistance Motor	94	3	#8 x 8mm Flange Screw
45	1	Motor Disc	95	45	#8 x 1/2" Screw
46	1	Tension Bracket	96	12	#3 x 5mm Screw
47	1	Tension Spring	97	15	5/16" x 3/4" Screw
48	1	Tension Pulley	98	4	#6 x 9.5mm Bolt
49	1	Tension Bushing	99	2	3/8" x 1" Screw
50	1	Resistance Bar	100	5	5/16" x 1/2" Screw

Key No.	Qty.	Description	Key No.	Qty.	Description
101	2	1/4" x 9.5mm Screw	119	1	#6 x 10mm Screw
102	1	M8 x 86mm Bolt	120	4	3/8" x 3/4" Screw
103	1	3/8" x 80mm Bolt	121	4	3/4" Washer
104	2	5/16" x 63.5mm Bolt	122	4	3/8" x 1" Patch Screw
105	2	1/4" x 22mm Screw	123	2	3/8" x 3/4" Patch Screw
106	1	#10 x 6.5mm Screw	124	2	3/8" x 3" Screw
107	10	M6 x 12mm Screw	125	1	#8 x 35mm Screw
108	10	#8 x 10mm Screw	126	8	#8 x 1" Tek Screw
109	1	3/8" x 41mm Bolt	127	4	1/4" x 3/4" Patch Screw
110	2	1/2" x 70mm Screw	128	2	M10 Split Washer
111	4	1/4" x 3/4" Screw	129	1	Accessory Tray
112	4	3/8" Locknut	130	2	Resistance Switch
113	1	M8 Locknut	131	2	Resistance Button
114	4	#6 Locknut	*	–	Audio/Video Component Cable
115	6	Clip	*	–	Audio Cable
116	2	M10 Flat Washer	*	–	User's Manual
117	2	1" Snap Ring	*	–	Assembly Tool
118	1	3/4" Snap Ring			

Note: Specifications are subject to change without notice. See the back cover of this manual for information about ordering replacement parts. \*These parts are not illustrated.



# EXPLODED DRAWING A—SFSR82308.0

R1208A

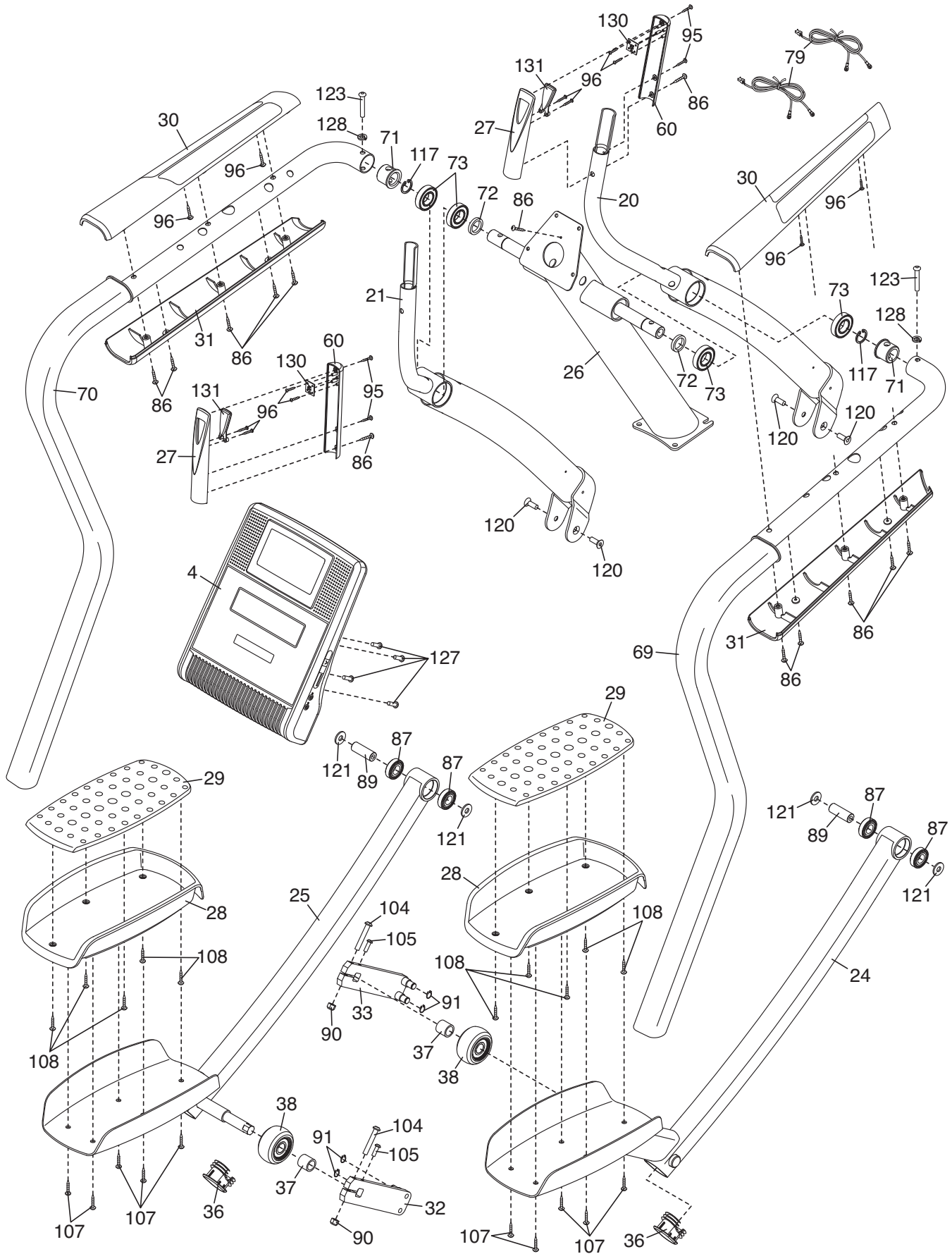

# EXPLODED DRAWING B—SFSR82308.0

R1208A

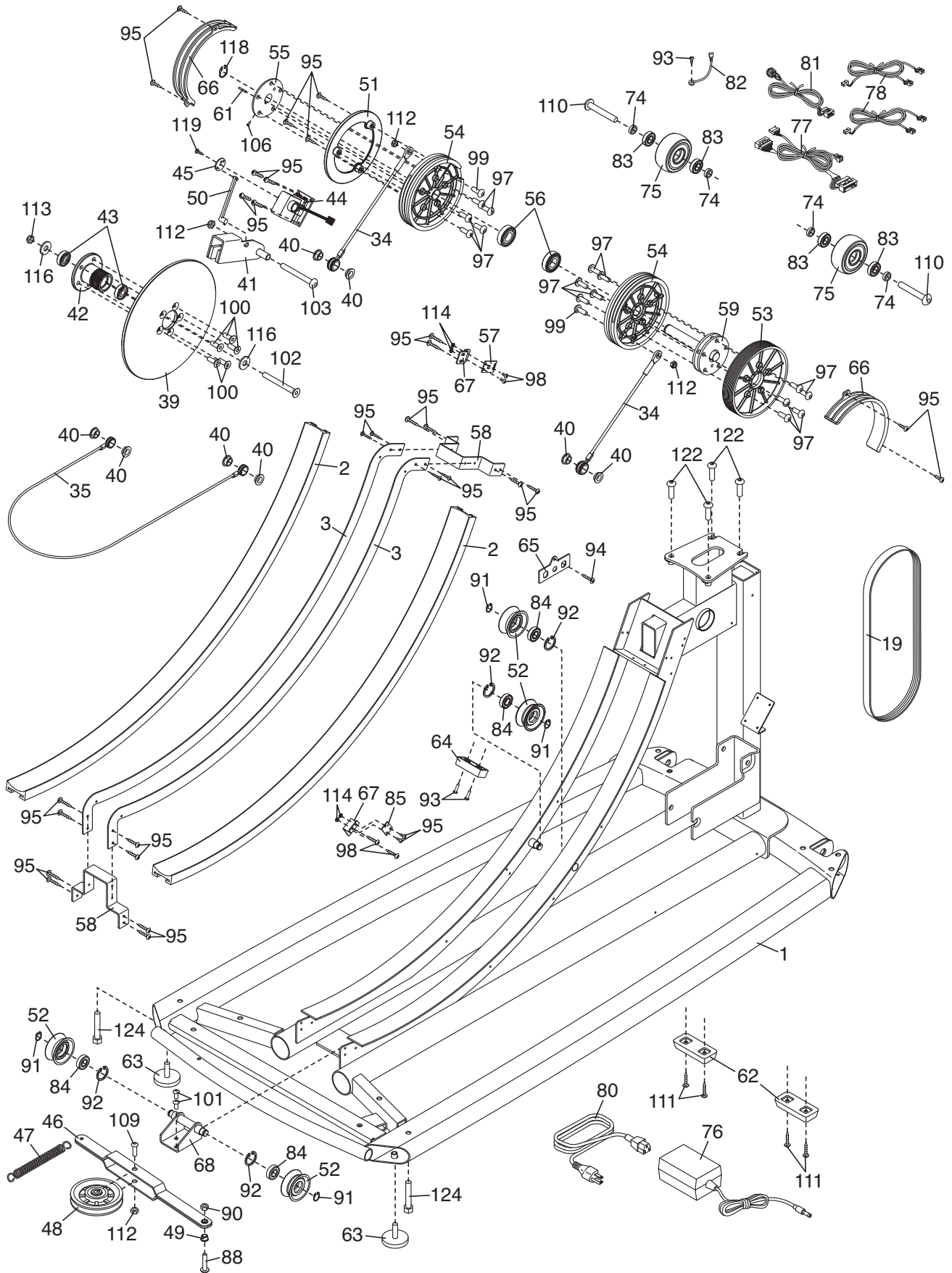

# EXPLODED DRAWING C—SFSR82308.0

R1208A

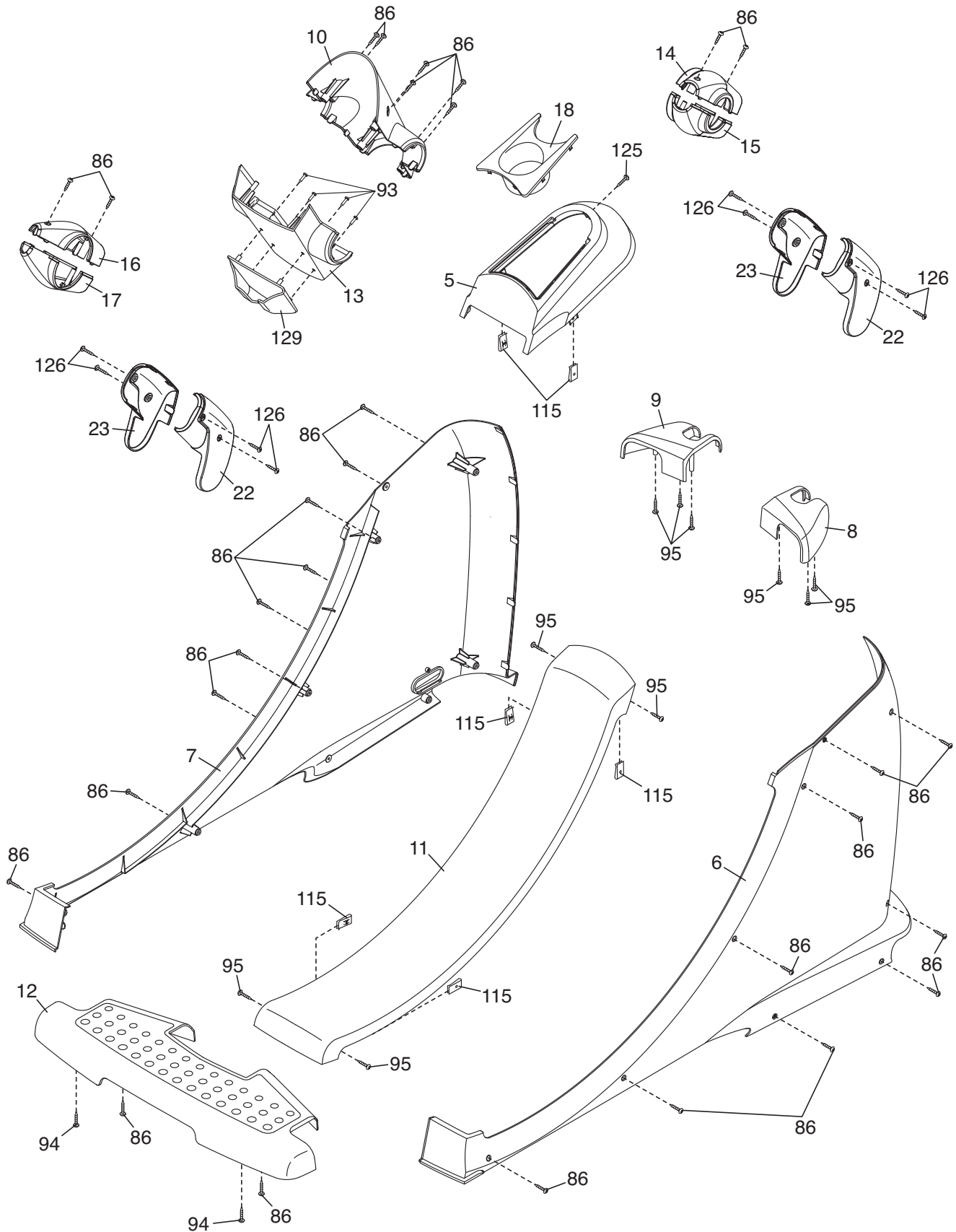

# HOW TO CONTACT CUSTOMER CARE

If you have questions after reading this manual, or if parts are damaged or missing, **please contact the store where you purchased this product.** If you are unable to contact the store, contact Customer Care at one of the phone numbers or addresses listed below. **Please note the model number, serial number, and name of the product (see the front cover of this manual) before contacting Customer Care. If you are ordering replacement parts, please also note the key number and description of each part (see the PART LIST and EXPLODED DRAWING near the end of this manual).**

**Inside the US, call toll free:** 1-866-799-8946, Mon.–Fri. 8 a.m.–5 p.m. MT

**Outside the US, call:** +1-719-533-2911

**US Email:** [fmvfcustomerservice@freemotionfitness.com](mailto:fmvfcustomerservice@freemotionfitness.com)

**International Email:** [intlcustomercare@freemotionfitness.com](mailto:intlcustomercare@freemotionfitness.com)

**Write:** FreeMotion Fitness, 1500 S. 1000 W., Logan, UT 84321-9813

## LIMITED WARRANTY

FreeMotion Fitness warrants this product to be free from defects in workmanship and material, under normal use and service conditions. The frame is warranted for a lifetime. Parts are warranted for seven (7) years from the date of purchase. Labor is warranted for one (1) year from the date of purchase.

FreeMotion Fitness warranty service may be obtained by contacting the authorized dealer from which you purchased this product. Make sure to retain your original invoice and serial number information. If this product experiences a failure under the warranty terms set forth, FreeMotion Fitness shall provide at their option repair, replacement, or refund of the purchase price. FreeMotion Fitness compensates service providers for warranty trips within their service area; you may be charged additionally for service calls beyond this service area. For replacement parts shipped while the product is under warranty, the customer will be responsible for a minimal handling charge. For in-home service, the customer will be responsible for a minimal trip charge. This warranty does not extend to any damage to a product caused by or attributable to freight damage, abuse, misuse, improper or abnormal usage, or repairs not provided by a FreeMotion authorized service center; products used for commercial or rental purposes; or products used as store display models. No other warranty beyond that specifically set forth above is authorized by FreeMotion Fitness.

FreeMotion Fitness is not responsible or liable for indirect, special, or consequential damages arising out of or in connection with the use or performance of the product; damages with respect to any economic loss, loss of property, loss of revenues or profits, loss of enjoyment or use, or costs of removal or installation; or other consequential damages of whatsoever nature. Some states do not allow the exclusion or limitation of incidental or consequential damages. Accordingly, the above limitation may not apply to you.

The warranty extended hereunder is in lieu of any and all other warranties, and any implied warranties of merchantability or fitness for a particular purpose are limited in their scope and duration to the terms set forth herein. Some states do not allow limitations on how long an implied warranty lasts. Accordingly, the above limitation may not apply to you.

This warranty gives you specific legal rights. You may also have other rights that vary from state to state.

**FreeMotion Fitness, Inc., 1500 S. 1000 W., Logan, UT 84321-9813**