

FREEMOTION[®] **511.8**

Model No. FMEX81110.0

Serial No. _____

Write the serial number in the space above for reference.

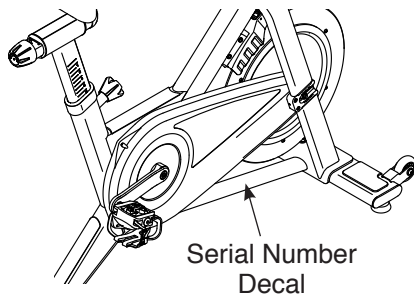

QUESTIONS?

If you have questions, or if parts are damaged or missing, please see **HOW TO CONTACT CUSTOMER CARE** on the back cover of this manual.

CAUTION

Read all precautions and instructions in this manual before using this equipment. Keep this manual for future reference.

USER'S MANUAL

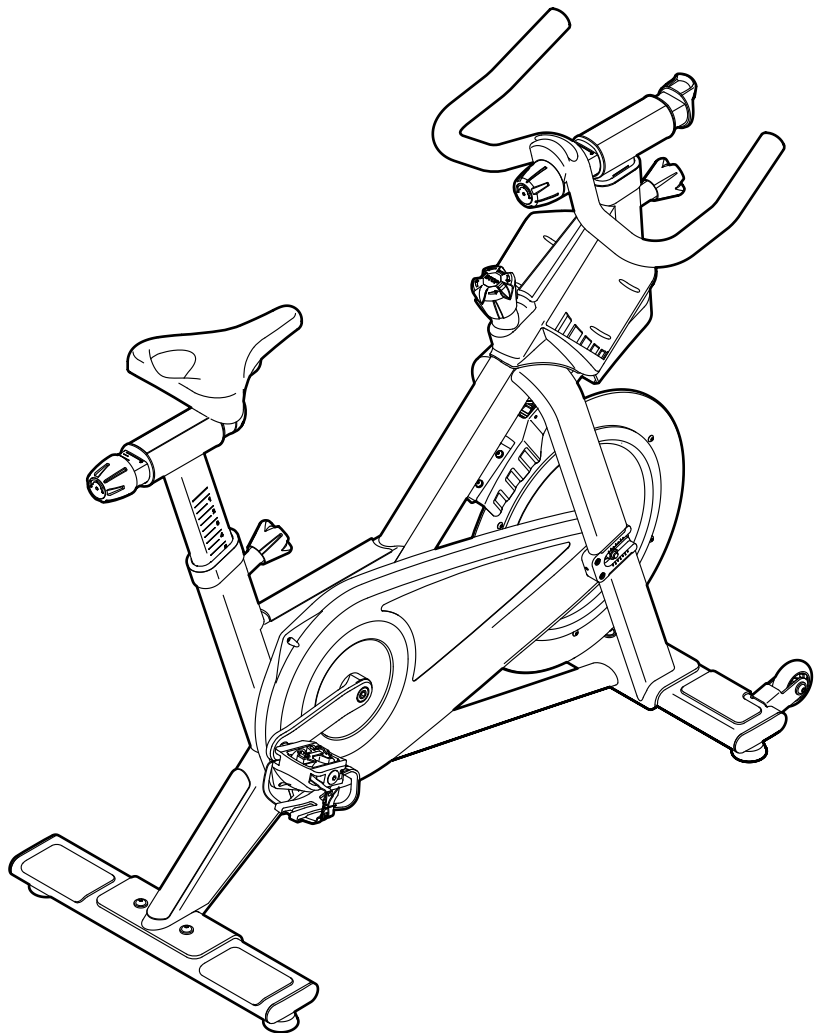

TABLE OF CONTENTS

WARNING DECAL PLACEMENT 2

IMPORTANT PRECAUTIONS..... 3

BEFORE YOU BEGIN..... 4

ASSEMBLY..... 5

HOW TO USE THE EXERCISE BIKE..... 8

PART LIST..... 10

EXPLODED DRAWING..... 11

HOW TO CONTACT CUSTOMER CARE..... Back Cover

WARNING DECAL PLACEMENT

This drawing shows the location(s) of the warning decal(s). **If a decal is missing or illegible, see the back cover of this manual and request a free replacement decal. Apply the decal in the location shown.** Warning decals in other languages are included. Apply the warning decals on top of the English warnings in the indicated location(s) if desired. Note: The decal(s) may not be shown at actual size.

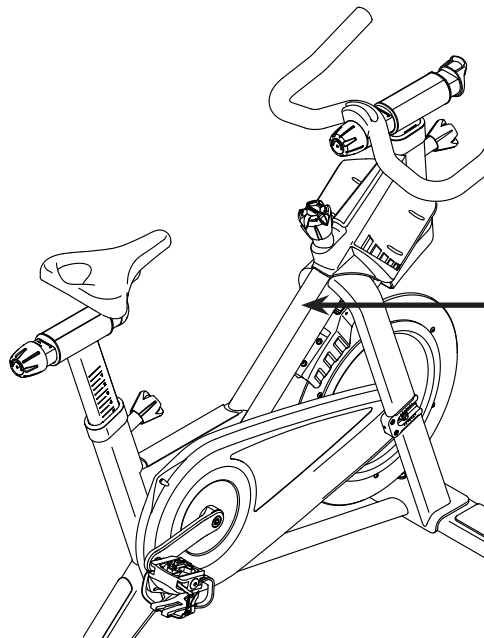

⚠ WARNING

- Misuse of this machine may result in serious injury.
- Read user's manual prior to use and follow all warnings and instructions.
- Do not allow children on or around machine.
- Pedals continue to spin when you stop pedaling.
- Spinning pedals can cause injury.
- Reduce pedal speed in a controlled manner.
- This bike does not freewheel.
- User weight must not exceed 350 lbs / 159 kgs.
- This product should always be used on a level surface.
- This product is not intended for therapeutic use.
- Replace label if damaged, illegible, or removed.



IMPORTANT PRECAUTIONS

⚠ WARNING: To reduce the risk of serious injury, read all important precautions and instructions in this manual and all warnings on your exercise bike before using your exercise bike. FreeMotion Fitness assumes no responsibility for personal injury or property damage sustained by or through the use of this product.

1. Before beginning any exercise program, consult your physician. This is especially important for persons over age 35 or persons with pre-existing health problems.
2. Use the exercise bike only as described in this manual.
3. It is the responsibility of the owner to ensure that all users of the exercise bike are adequately informed of all precautions.
4. The exercise bike is intended for use in a supervised environment only.
5. Keep the exercise bike indoors, away from moisture and dust. Do not put the exercise bike in a garage or covered patio, or near water.
6. Place the exercise bike on a level surface, with a mat beneath it to protect the floor or carpet. Make sure that there is at least 2 ft. (0.6 m) of clearance around the exercise bike.
7. Inspect and properly tighten all parts regularly. Replace any worn parts immediately.
8. Keep children under age 12 and pets away from the exercise bike at all times.
9. Wear appropriate clothes while exercising; do not wear loose clothes that could become caught on the exercise bike. Always wear athletic shoes for foot protection.
10. The exercise bike should not be used by persons weighing more than 350 lbs. (159 kg).
11. Always keep your back straight while using the exercise bike; do not arch your back.
12. The exercise bike does not have a freewheel; the pedals will continue to move until the flywheel stops. Reduce your pedaling speed in a controlled way.
13. To stop the flywheel quickly, press the resistance knob downward.
14. When the exercise bike is not in use, tighten the resistance knob completely to prevent the flywheel from moving.
15. Over exercising may result in serious injury or death. If you feel faint or if you experience pain while exercising, stop immediately and cool down.

BEFORE YOU BEGIN

Thank you for selecting the new FREEMOTION® S11.8 exercise bike. Cycling is an effective exercise for increasing cardiovascular fitness, building endurance, and toning the body. The S11.8 exercise bike provides a selection of features designed to make your workouts more effective and enjoyable.

For your benefit, read this manual carefully before you use the exercise bike. If you have questions after

reading this manual, please see the back cover of this manual. To help us assist you, note the product model number and serial number before contacting us. The model number and the location of the serial number decal are shown on the front cover of this manual.

Before reading further, please familiarize yourself with the parts that are labeled in the drawing below.

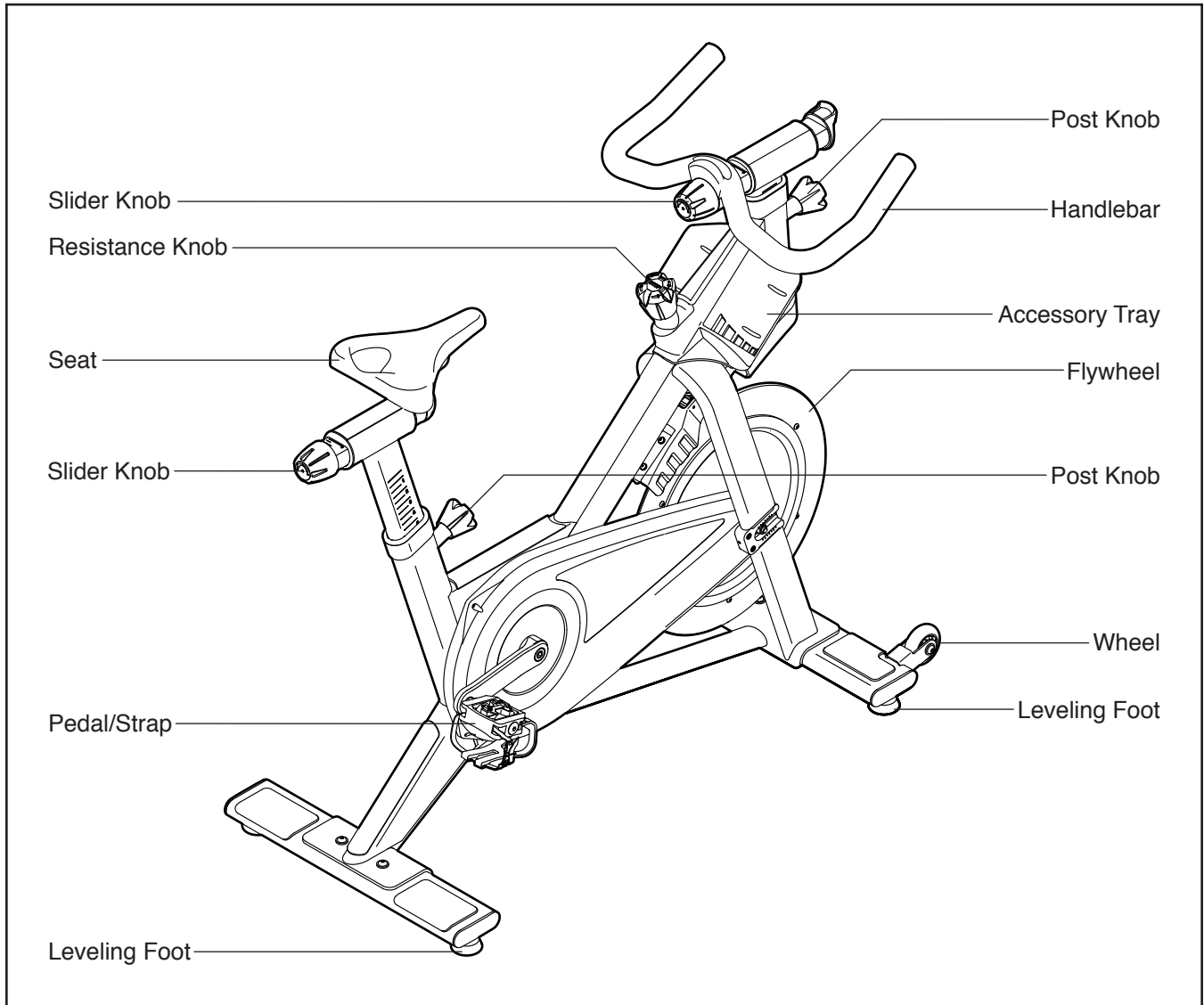

ASSEMBLY

- Assembly requires two persons.
- Place all parts in a cleared area and remove the packing materials. Do not dispose of the packing materials until you complete all assembly steps.
- If a part is not in the hardware kit, check to see if it has been preassembled. To avoid damaging parts, do not use power tools for assembly.

- Assembly requires the following tools (not included):

one adjustable wrench



one 6 mm hex key



Assembly may be easier if you have a socket set or a set of ratchet wrenches. To avoid damaging parts, do not use power tools.

1. Attach the Front Stabilizer (8) to the Frame (1) with two M10 x 50mm Button Patch Bolts (73), four M10 Washers (67), and two M10 Locknuts (74).

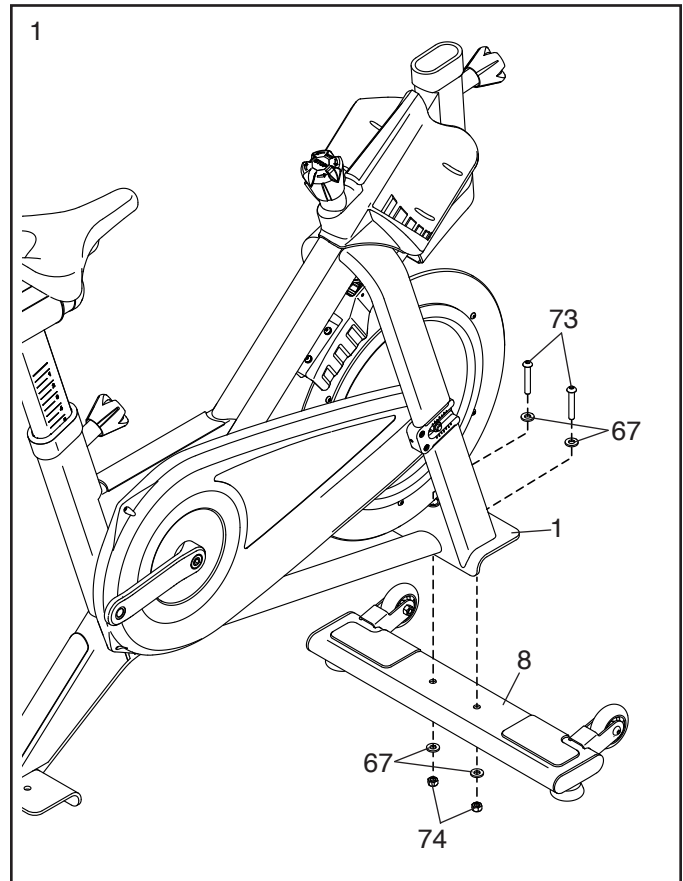

2. Attach the Rear Stabilizer (7) to the Frame (1) with two M10 x 50mm Button Patch Bolts (73), four M10 Washers (67), and two M10 Locknuts (74).

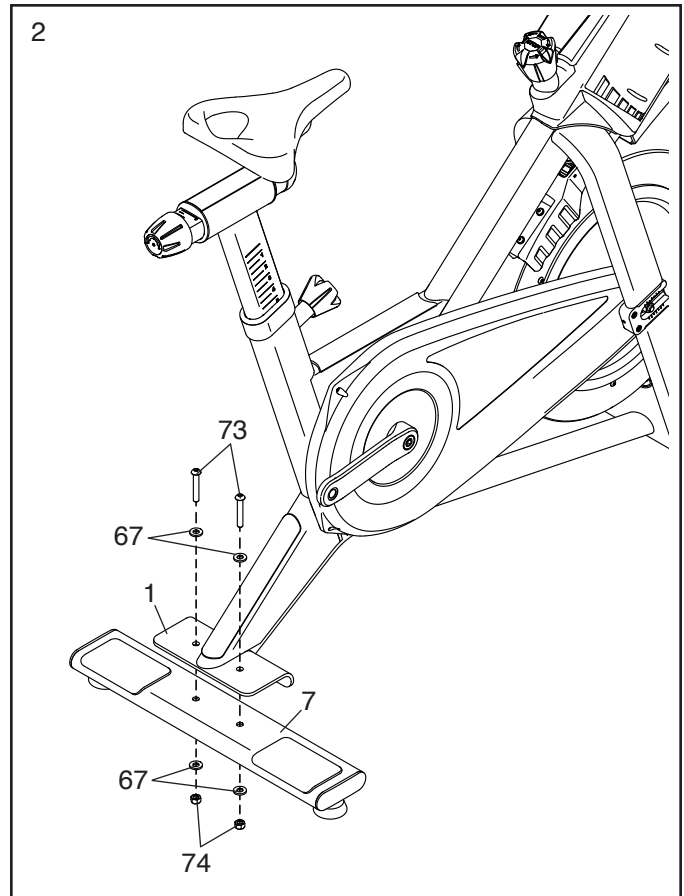

3. Orient the Handlebar Post (2) as shown.

Loosen the Post Knob (32) on the front of the Frame (1) and pull it outward. Then, insert the Handlebar Post (2) into the Frame.

Move the Handlebar Post (2) upward or downward to the desired position, release the Post Knob (32) into an adjustment hole in the Handlebar Post, and then tighten the Post Knob. **Make sure that the Post Knob is firmly engaged in an adjustment hole.**

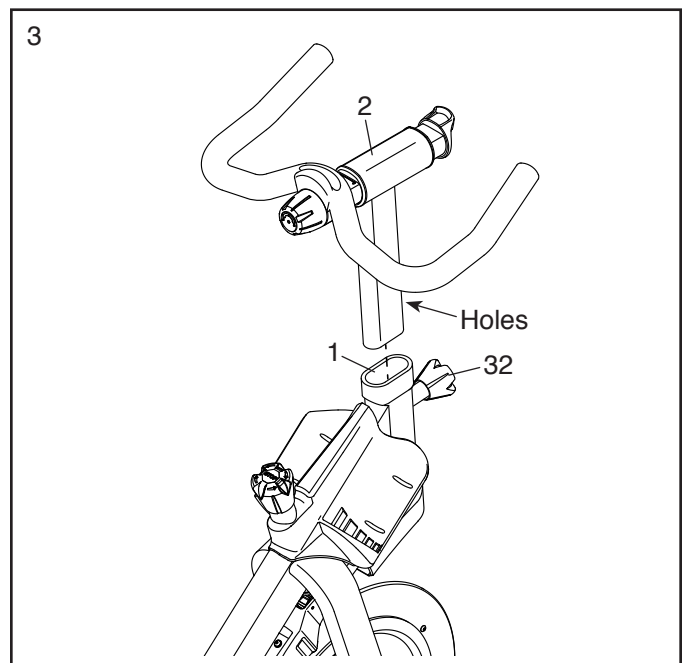

4. Identify the Right Pedal (15), which is marked with an “R.”

Using an adjustable wrench, **firmly tighten** the Right Pedal (15) and a Pedal Washer (85) **clockwise** into the Right Crank Arm (14).

Tighten the Left Pedal (not shown) and a Pedal Washer (not shown) **counterclockwise** into the Left Crank Arm (not shown).

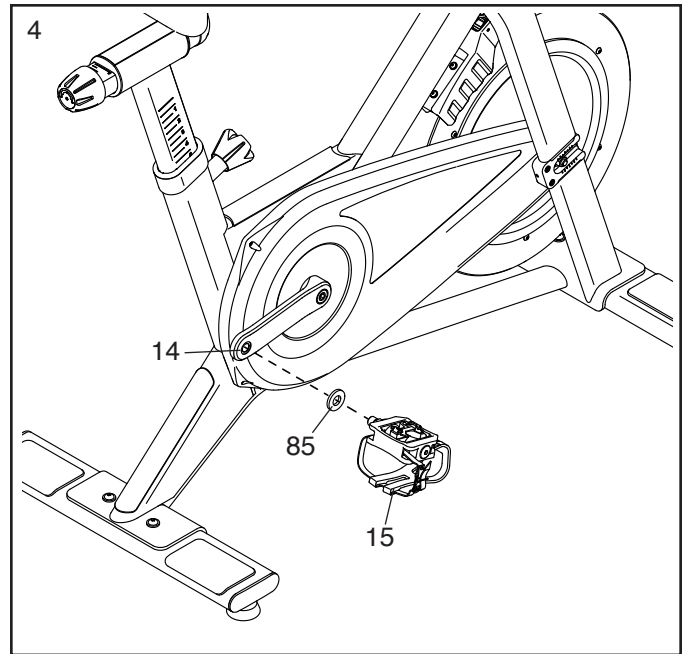

5. Place the exercise bike in the location where it will be used. **Tip: Place a mat beneath the exercise bike to protect the floor.**

Make sure that all four Leveling Feet (29) are in contact with the floor.

If the Leveling Feet (29) are not in contact with the floor, loosen or tighten the Leveling Feet on the Rear and Front Stabilizers (7, 8) until all four Leveling Feet contact the floor.

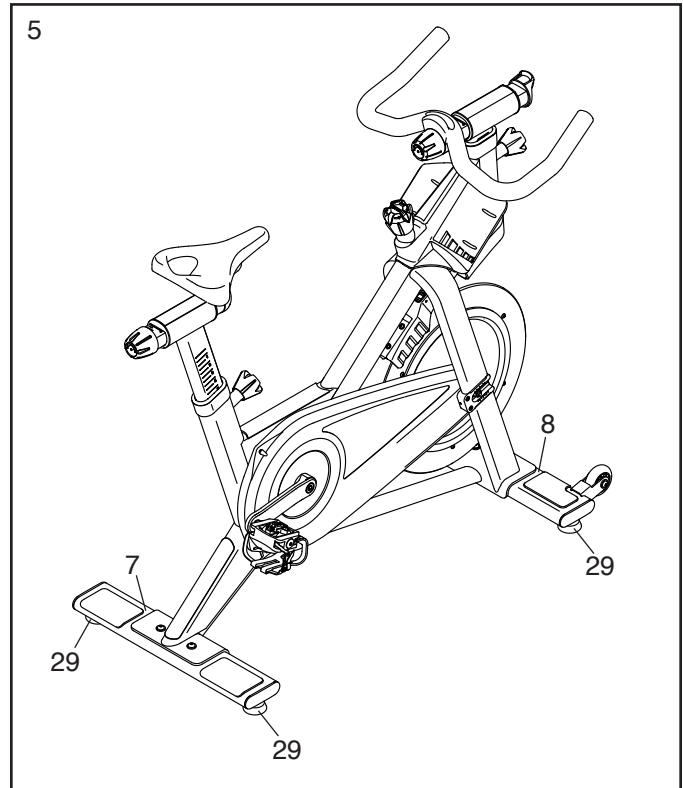

6. **Make sure that all parts are properly tightened before you use the exercise bike.** Note: After assembly is completed, some extra parts may be left over.

HOW TO USE THE EXERCISE BIKE

HOW TO ADJUST THE SEAT

You can adjust the angle of the seat to the position that is most comfortable. You can also slide your seat forward or backward to increase your comfort or to adjust the distance to the handlebar.

To adjust the seat, first loosen the hex nuts on the seat clamp a few turns. Next, tilt the seat upward or downward or slide the seat forward or backward to the desired position. Then, retighten the hex nuts.

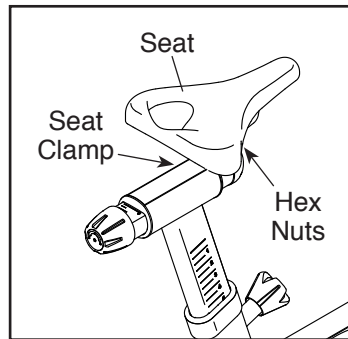

HOW TO ADJUST THE SEAT CARRIAGE

To adjust the position of the seat carriage, loosen the slider knob, move the seat carriage forward or backward to the desired position, and then firmly tighten the slider knob.

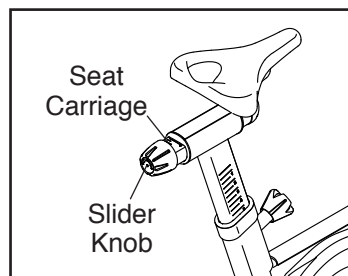

HOW TO ADJUST THE SEAT POST

For effective exercise, the seat should be at the proper height. As you pedal, there should be a slight bend in your knees when the pedals are in the lowest position.

To adjust the seat post, first loosen the post knob and pull it outward. Then, move the seat post upward or downward, release the post knob into an adjustment hole in the seat post, and firmly tighten the post knob.

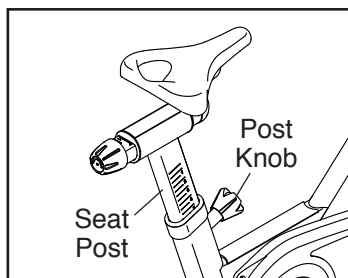

Make sure that the post knob is engaged in an adjustment hole. IMPORTANT: Do not adjust the seat post beyond the stop mark on the seat post.

HOW TO ADJUST THE HANDLEBAR

To adjust the position of the handlebar, loosen the slider knob, move the handlebar forward or backward to the desired position, and then firmly tighten the slider knob.

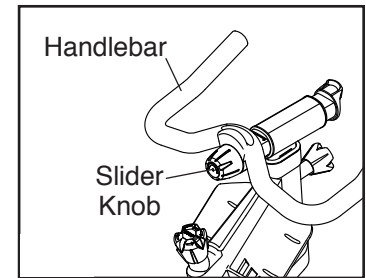

HOW TO ADJUST THE HANDLEBAR POST

To adjust the handlebar post, first loosen the post knob and pull it outward. Then, move the handlebar post upward or downward, release the post knob into an adjustment hole in the handlebar post, and firmly tighten the post knob.

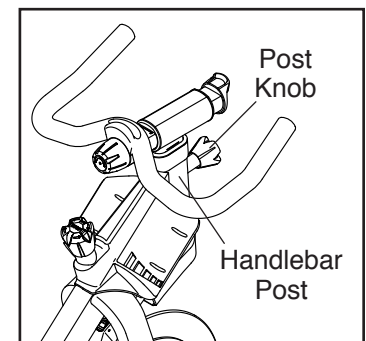

Make sure that the post knob is engaged in an adjustment hole. IMPORTANT: Do not adjust the handlebar post beyond the stop mark on the handlebar post.

HOW TO USE THE PEDALS

To use the toe cage side of the pedals (see the drawing on page 4), insert your shoes into the toe cages and pull the ends of the toe straps. To adjust the toe straps, press and hold the tabs on the buckles, adjust the toe straps to the desired position, and then release the tabs.

To use the clip-in side of the pedals, you must wear cycling shoes. To clip into the pedals, press the cleats on your cycling shoes firmly into the slots in the pedals until they snap into place. To unclip from the pedals, twist your cycling shoes outward from the pedals.

HOW TO ADJUST THE PEDALING RESISTANCE

To increase the resistance of the pedals, turn the resistance knob clockwise; to decrease the resistance, turn the resistance knob counterclockwise.

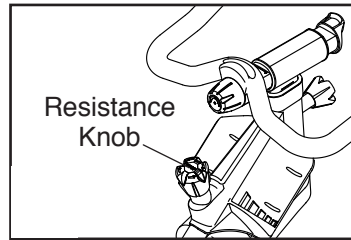

To stop the flywheel, push the resistance knob downward. The flywheel should quickly come to a complete stop.

IMPORTANT: When the exercise bike is not in use, tighten the resistance knob completely.

HOW TO LEVEL THE EXERCISE BIKE

If the exercise bike rocks slightly on your floor during use, turn one or both of the leveling feet on the front or rear stabilizer (see the drawing on page 4) until the rocking motion is eliminated.

HOW TO MAINTAIN THE EXERCISE BIKE

Inspect and tighten all parts of the exercise bike regularly. Replace any worn parts immediately.

To clean the exercise bike, use a damp cloth and a small amount of mild detergent.

For maximum performance and safety, replace the pedals every year. **To purchase pedals, see the back cover of this manual.**

IMPORTANT: To avoid damage to the exercise bike and to prevent injury to the user, use only manufacturer-supplied pedals. Other pedals may not be designed for use in fitness clubs or indoor cycling studios and may be dangerous.

PART LIST

Model No. FMEX81110.0 R0711A

Key No.	Qty.	Description	Key No.	Qty.	Description
1	1	Frame	46	2	Cap Bushing
2	1	Handlebar Post	47	2	Medium E-clip
3	1	Handlebar	48	1	Sensor Magnet
4	1	Seat Post	49	1	Resistance Block
5	1	Seat Carriage	50	2	M22 Sleeve Nut
6	1	Seat	51	2	M22 x 30mm Washer
7	1	Rear Stabilizer	52	2	Large E-clip
8	1	Front Stabilizer	53	2	11mm x 20mm Washer
9	1	Flywheel	54	1	Block Pin
10	1	Accessory Tray	55	2	Small E-clip
11	1	Resistance Cover	56	1	M3 x 6mm Flat Head Patch Screw
12	1	Resistance Arm	57	2	M5 Washer
13	1	Eddy Magnet	58	2	M5 Star Washer
14	1	Right Crank Arm	59	2	M5 x 10mm Button Screw
15	1	Right Pedal	60	12	M4 x 8mm Button Patch Screw
16	1	Left Crank Arm	61	1	M8 x 51mm x M6 Shoulder Bolt
17	1	Left Pedal	62	1	M6 x 18mm Hex Screw
18	1	Bottom Bracket	63	1	M6 Locknut
19	1	Outer Shield	64	10	M4 x 20mm Socket Screw
20	1	Chain	65	2	M5 x 30mm Set Screw
21	1	Inner Shield	66	2	3/8" Nut
22	1	Sensor Cover	67	10	M10 Washer
23	1	Seat Post Selector	68	8	M4 x 10mm Flat Head Patch Screw
24	1	Handlebar Post Selector	69	2	M5 x 16mm Socket Patch Screw
25	2	Front Frame Bushing	70	4	M5 x 16mm Flat Head Patch Screw
26	2	Rear Frame Bushing	71	2	M4 x 8mm Cap Screw
27	1	Tension Spring	72	2	M4 x 20mm Flat Head Patch Screw
28	2	Wheel	73	4	M10 x 50mm Button Patch Bolt
29	4	Leveling Foot	74	4	M10 Locknut
30	2	Pin Assembly	75	4	M4 Washer
31	2	20mm x 25mm Washer	76	2	M6 x 40mm Button Patch Bolt
32	2	Post Knob	77	4	M6 Washer
33	2	Slider Knob	78	2	M6 Nut
34	1	Resistance Knob	79	5	M4 x 7mm Socket Screw
35	2	Knob Cap	80	1	Sensor Cover Screw
36	2	Wedge Cap	81	2	Crank Screw
37	2	M8 x 30mm Washer	82	2	Resistance Bushing
38	2	Adjustment Rod	83	1	Brake Pad
39	4	Ring Cap	84	2	Post Knob Cap
40	1	Handlebar Retainer	85	2	Pedal Washer
41	1	Handlebar Cap	86	1	Right Front Stabilizer Cover
42	2	Upper Wedge	87	2	Rear Stabilizer Cover
43	2	Lower Wedge	88	1	Left Front Stabilizer Cover
44	2	Sleeve	*	-	User's Manual
45	2	Post Shield			

Note: Specifications are subject to change without notice. For information about ordering replacement parts, see the back cover of this manual. *These parts are not illustrated.

EXPLODED DRAWING

Model No. FMEX81110.0 R0711A

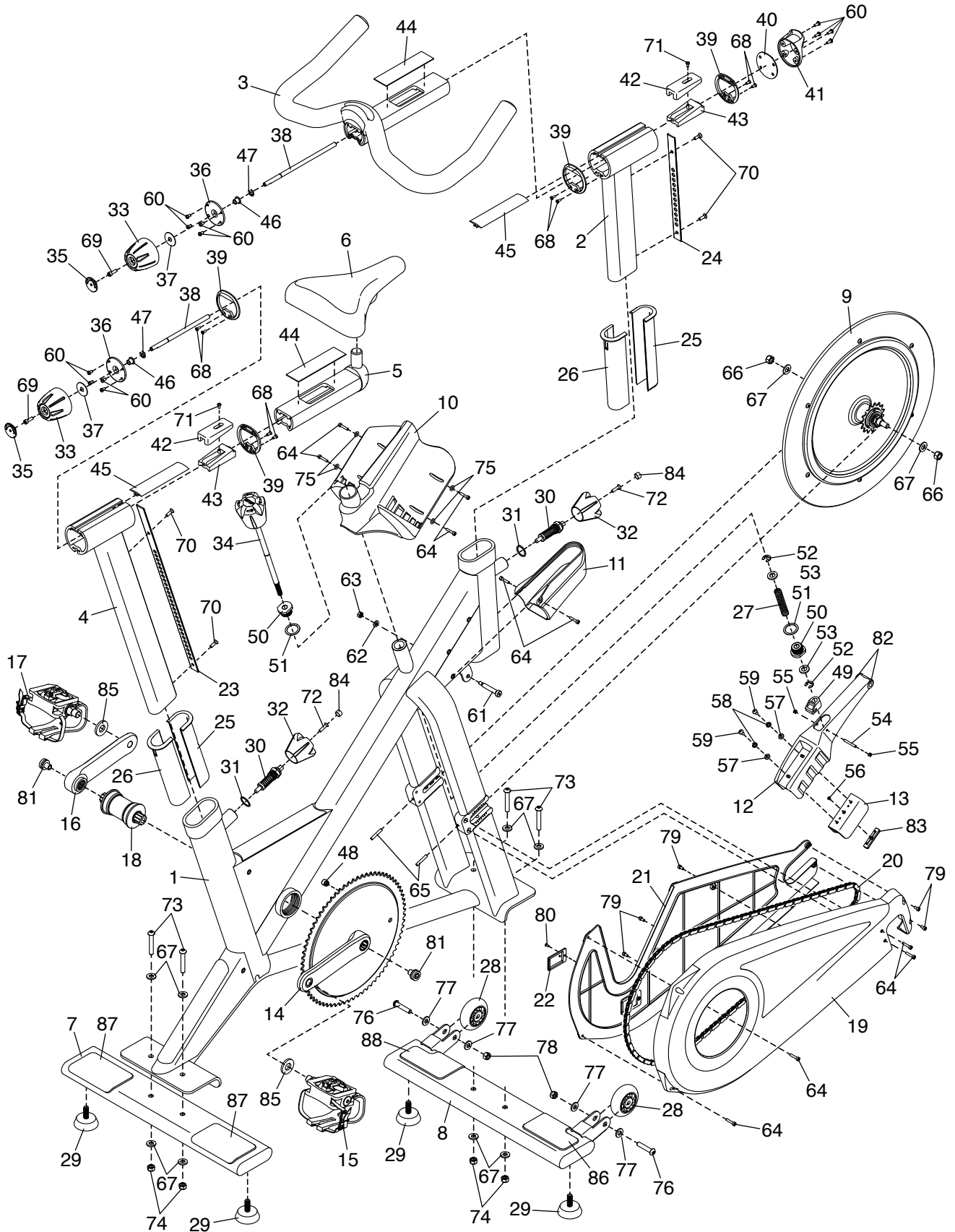

HOW TO CONTACT CUSTOMER CARE

If you have questions after reading this manual, or if parts are damaged or missing, please contact Customer Care at the phone numbers or addresses listed below. **Please note the model number, serial number, and name of the product (see the front cover of this manual) before contacting Customer Care. If you are ordering replacement parts, please also note the key number and description of each part (see the PART LIST and the EXPLODED DRAWING near the end of this manual).**

In the United States and Canada

Call: 1-800-201-2109, Mon.–Fri. 8 a.m.–5 p.m. MT

Write:

FreeMotion Fitness
1500 South 1000 West
Logan, UT 84321-9813
United States

Outside the United States and Canada

Call: 001-435-786-3521

Email: intlcustomercare@freemotionfitness.com