

TreadClimber[®]
by **BOWFLEX[®]**

TC5



Manual en Español Latino Americano: <http://support.nautilus.com>

Assembly Manual

Table of Contents



Important Safety Instructions	3
Specifications and Tools.....	4
Before Assembly.....	5
Parts	6
Hardware	8
Assembly.....	9
Adjustments.....	23

If you have questions or problems with your product, please call 1 (800) 605–3369.

Nautilus, Inc., (800) NAUTILUS / (800) 628-8458, www.NautilusInc.com - Customer Service: North America (800) 605-3369, tcinquiry@nautilus.com | outside U.S. +01-360-859-5180, technics-APLA@nautilus.com | Printed in China | © 2011 Nautilus, Inc., All rights reserved. ™ and ® indicate a trademark or registered trademark. Nautilus, Inc. (www.NautilusInc.com) trademarks include NAUTILUS®, BOWFLEX®, SCHWINN®, TreadClimber® and UNIVERSAL® and respective logos. Other trademarks are the property of their respective owners.



This icon means a potentially hazardous situation which, if not avoided, could result in death or serious injury.

Obey the following warnings:



Read and understand all Warnings on this machine.

Carefully read and understand the Assembly Manual.

- Keep bystanders and children away from the product you are assembling at all times.
- Do not connect power supply to the machine until instructed to do so.
- Do not assemble this machine outdoors or in a wet or moist location.
- Make sure assembly is done in an appropriate work space away from foot traffic and exposure to bystanders.
- Some components of the machine can be heavy or awkward. Use a second person when doing the assembly steps involving these parts. Do not do steps that involve heavy lifting or awkward movements on your own.
- Set up this machine on a solid, level, horizontal surface.
- Do not try to change the design or functionality of this machine. This could compromise the safety of this machine and will void the warranty.
- If replacement parts are necessary, use only genuine replacement parts and hardware supplied by Nautilus. Failure to use genuine replacement parts can cause a risk to users, keep the machine from operating correctly and void the warranty.
- Do not use until the machine has been fully assembled and inspected for correct performance in accordance with the Owner's Manual.
- Read and understand the complete Owner's Manual supplied with this machine before first use. Keep the Owner's and Assembly Manuals for future reference.
- Do all assembly steps in the sequence given. Incorrect assembly can lead to injury or malfunctioning of the machine.
- Be aware that in the normal operation of the machine, treadle movement is mechanically linked to the walking motion on the belts. When the walk belts are not in motion, the treadles will rest in a fixed position. In the event that an object becomes lodged between the treadles, the treadles can be manually moved in one of the following 2 ways:
 - a. Push downward on the outside foot rail of the lowest treadle with your foot or hand, and the treadles will move allowing release of the object.
 - b. Push down and back on the walk belt of the lowest treadle with your foot or hand, and the treadles will move allowing release of the object.



Take care not to allow children or pets to play on or around the machine.

Specifications and Tools



Included



#1
5 mm
6 mm

Not Included



#2 Short



(recommended)



13 mm (1/2")



(recommended)

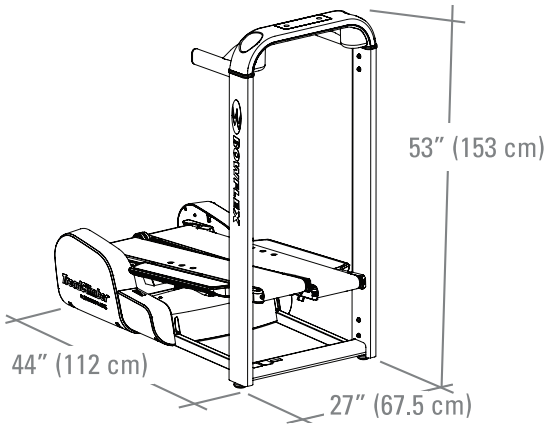

Required: 2 AA size batteries (LR6), which are not included.



Select the area where you are going to set up and operate your machine. For safe operation, the location must be on a hard, level surface. Allow a minimum workout area of 66" x 123" (167.6 cm x 312.4 cm).

Basic Assembly Tips

Follow these basic points when you assemble your machine:

- Read and understand the “Important Safety Instructions” before assembly.
- Collect all the pieces necessary for each assembly step.
- Using the recommended wrenches, turn the bolts and nuts to the right (clockwise) to tighten, and the left (counterclockwise) to loosen, unless instructed otherwise.
- When attaching 2 pieces, lightly lift and look through the bolt holes to help insert the bolt through the holes.
- The assembly requires 2 people.
- Do not use any power tools for assembly.

Machine Mat

The Bowflex® TreadClimber® Machine Mat is an optional accessory that helps keep your workout area clear and adds a layer of protection to your floor. The rubber machine mat provides a non-slip, rubber surface which limits static discharge and reduces the possibility of display or running errors. If possible, put your Bowflex® TreadClimber® Machine Mat in your selected workout area before you begin assembly.

To order the optional machine mat, go to: www.bowflex.com, or call 1 (800) 605–3369.

BOX 1

(2 BOXES)

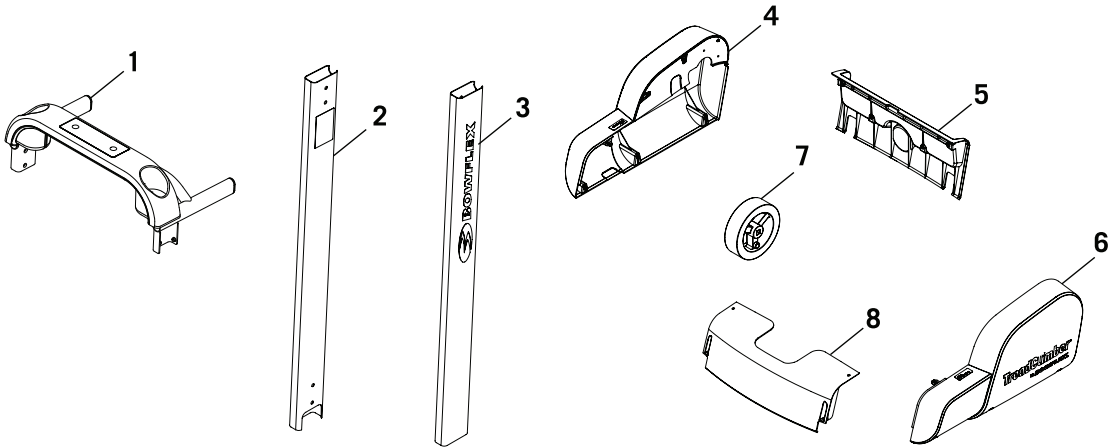

Item	Qty	Description	Item	Qty	Description
1	1	Console / Handlebar Assembly	5	1	Rear Cover
2	1	Upright, Right	6	1	Side Cover, Left
3	1	Upright, Left	7	1	Flywheel Assembly
4	1	Side Cover, Right	8	1	Front Cover



BOX 2

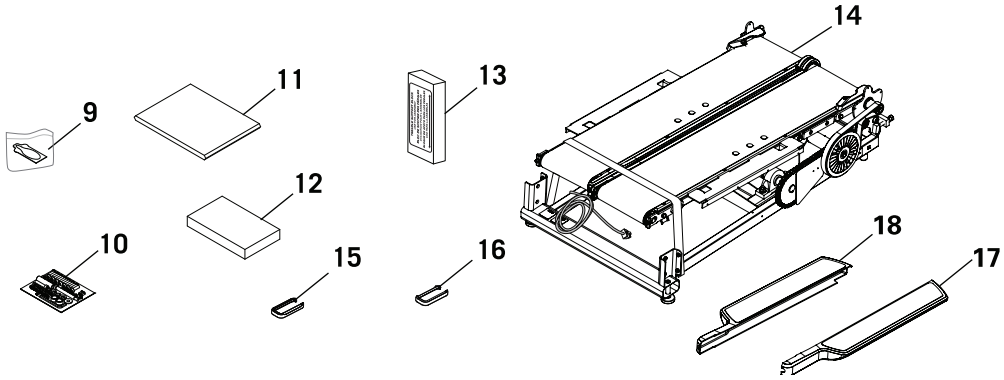

Item	Qty	Description	Item	Qty	Description
9	1	Belt Lubrication Kit	14	1	Treadle Assembly *
10	1	Hardware Card	15	1	Junction Cover, Right
11	1	Document Kit	16	1	Junction Cover, Left
12	1	Bowflex® Weight Loss Plan	17	1	Foot Rail Cover, Left
13	1	Treadle Support Block	18	1	Foot Rail Cover, Right

*Do not cut Shipping Strap until instructed.

Hardware

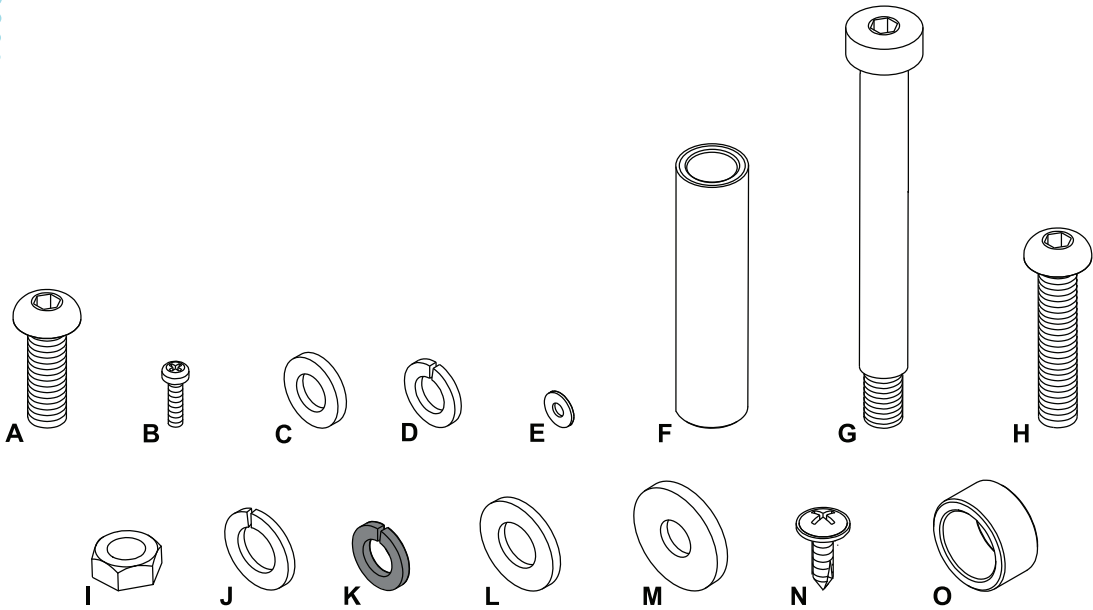

Item	Qty	Description	Item	Qty	Description
A	14	Button Head Hex Screw, M8x25	I	1	Hex Nut, M8
B	4	Phillips Screw, M4x12	J	1	Lock Washer, M10x18
C	14	Flat Washer, M8x16	K	1	Lock Washer, M8x14.8 Black
D	14	Lock Washer, M8x14	L	2	Flat Washer, M8x21
E	4	Flat Washer, M4x10	M	1	Flat Washer, M8x24 Wide Black
F	1	Bearing Tube	N	22	Phillips Screw, M4x16 Self Tapping
G	1	Socket Head Hex Screw, M10x75	O	2	Spacer
H	1	Button Head Hex Screw, M8x40			

! Do not wear loose clothing or jewelry. This machine contains moving parts. Do not put fingers or other objects into moving parts of the exercise equipment.

! Some components of the machine can be heavy or awkward. Use a second person when doing the assembly steps involving these parts. Do not do steps that involve heavy lifting or awkward movements on your own.

1. Cut open the end of Box 2 and move the Treadle Assembly into your new fitness area

Note: Lift with the Transport Handle Bar and not the Treadles. Do not remove the Shipping Strap until instructed.

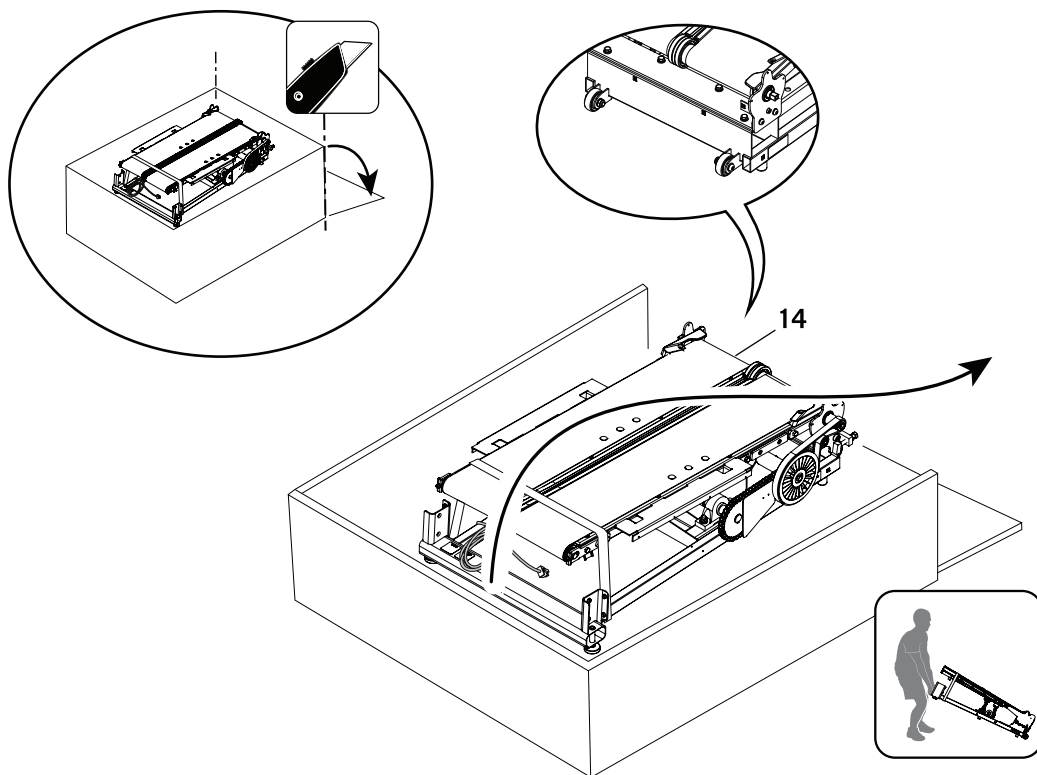

2. Cut the Shipping Strap and place the Treadle Support Block under the Treadles

Note: Do not lift the Treadles more than necessary to place the Support Block.

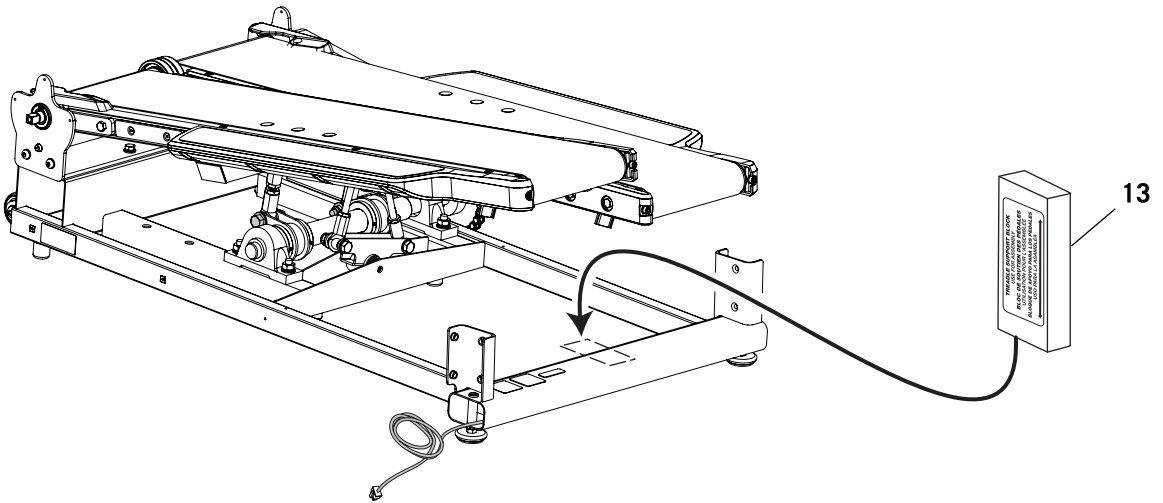

3. Inspect and Adjust the One Way Bearings

Both of the One Way Bearings must be toward the Transport Wheels, or the back of the machine.

If either of the One Way Bearings are forward, they must be adjusted. From the front of the machine, grasp each Treadle by the Walking Belt and lift. While fully lifting each Treadle, roll each of the Walking Belts toward the back of the machine. Continue this operation until both of the One Way Bearings are to the back and in the operation zone. Lower the Treadles onto the Treadle Support Block.

⚠ The Walking Belts can abruptly move. To avoid possible serious injury, keep hands away from the edges of the Walking Belts.

Be aware that the Drive Chain and the Walking Belts are connected and when either of these parts move the other does as well. In order to avoid possible serious injury, do not allow anything to be caught or pinched by the Drive Chain when the Walking Belts are moved.

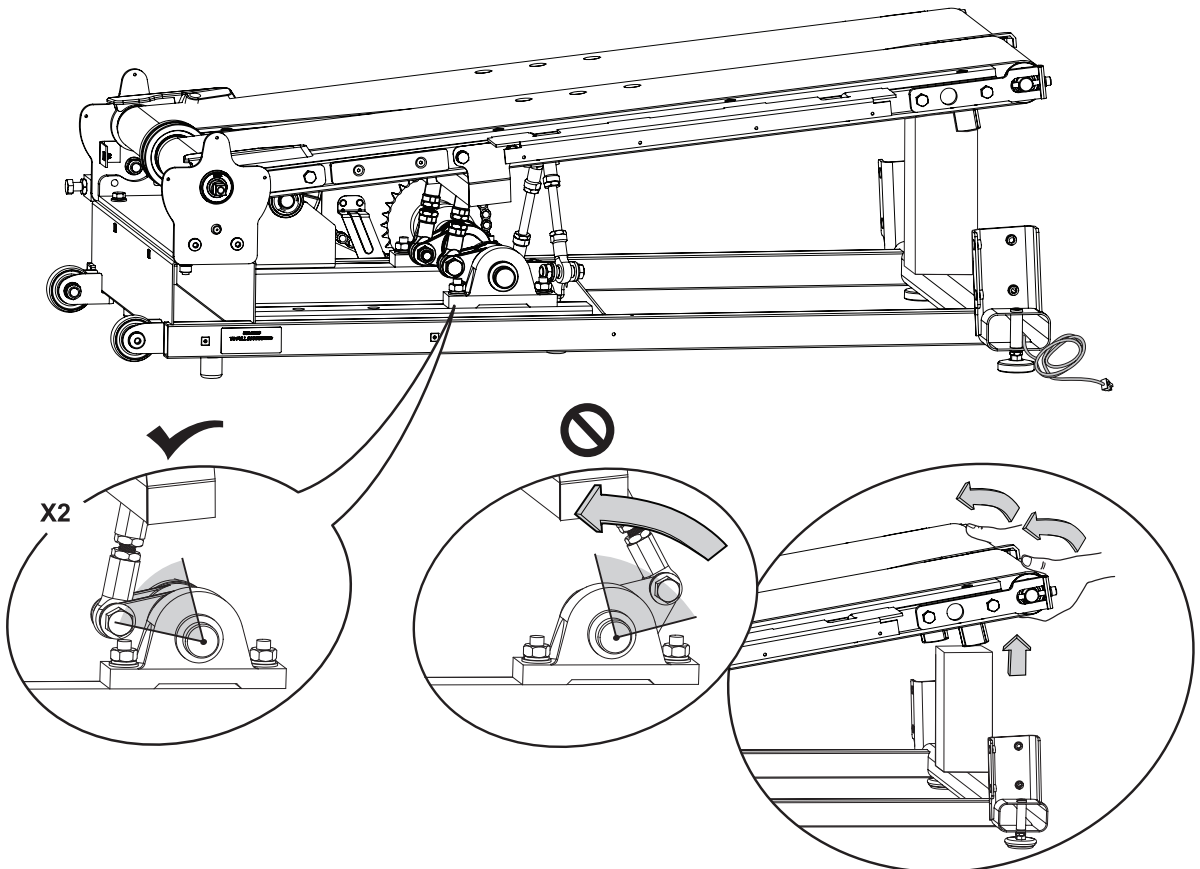

4. Connect the Dependency to the Treadle Assembly

Note: The Walking Belts may need to be slightly adjusted to align the bolt holes. Remove the Treadle Support Block after tightening hardware.

! The Walking Belts can abruptly move. To avoid possible serious injury, keep hands away from the edges of the Walking Belts.

Be aware that the Drive Chain and the Walking Belts are connected and when either of these parts move the other does as well. In order to avoid possible serious injury, do not allow anything to be caught or pinched by the Drive Chain when the Walking Belts are moved.

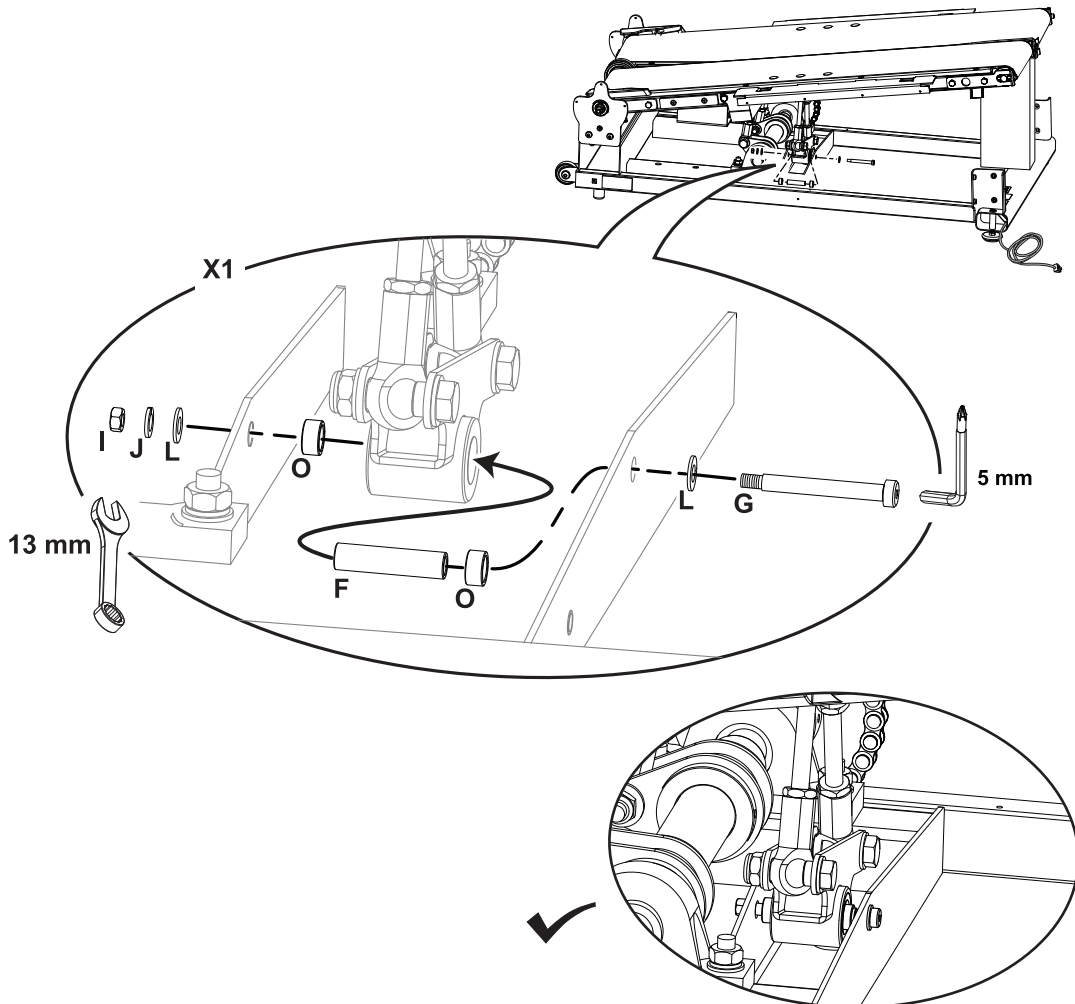

5. Attach the Foot Rail Covers to the Treadle Assembly

! The Walking Belts can abruptly move. To avoid possible serious injury, keep hands away from the edges of the Walking Belts.

Be aware that the Drive Chain and the Walking Belts are connected and when either of these parts move the other does as well. In order to avoid possible serious injury, do not allow anything to be caught or pinched by the Drive Chain when the Walking Belts are moved.

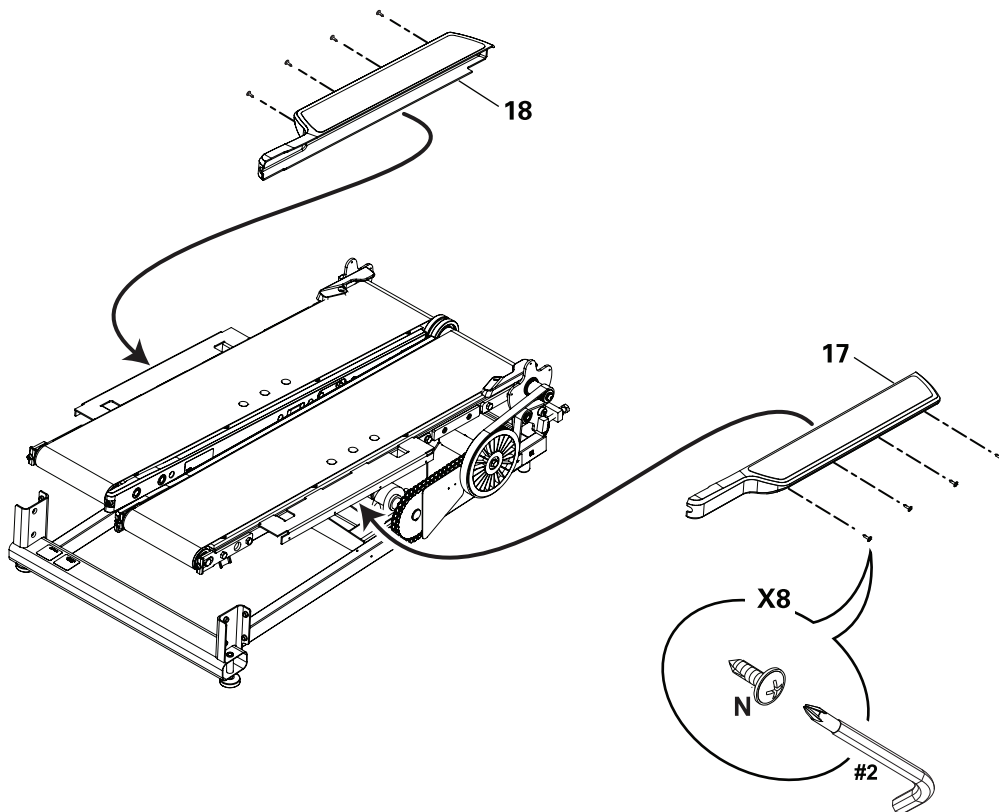

6. Run the Speed Sensor Cable through the Right Upright

Note: Speed Sensor Cable may be inside Transport Hand Bar.
Do not crimp the Speed Sensor Cable.

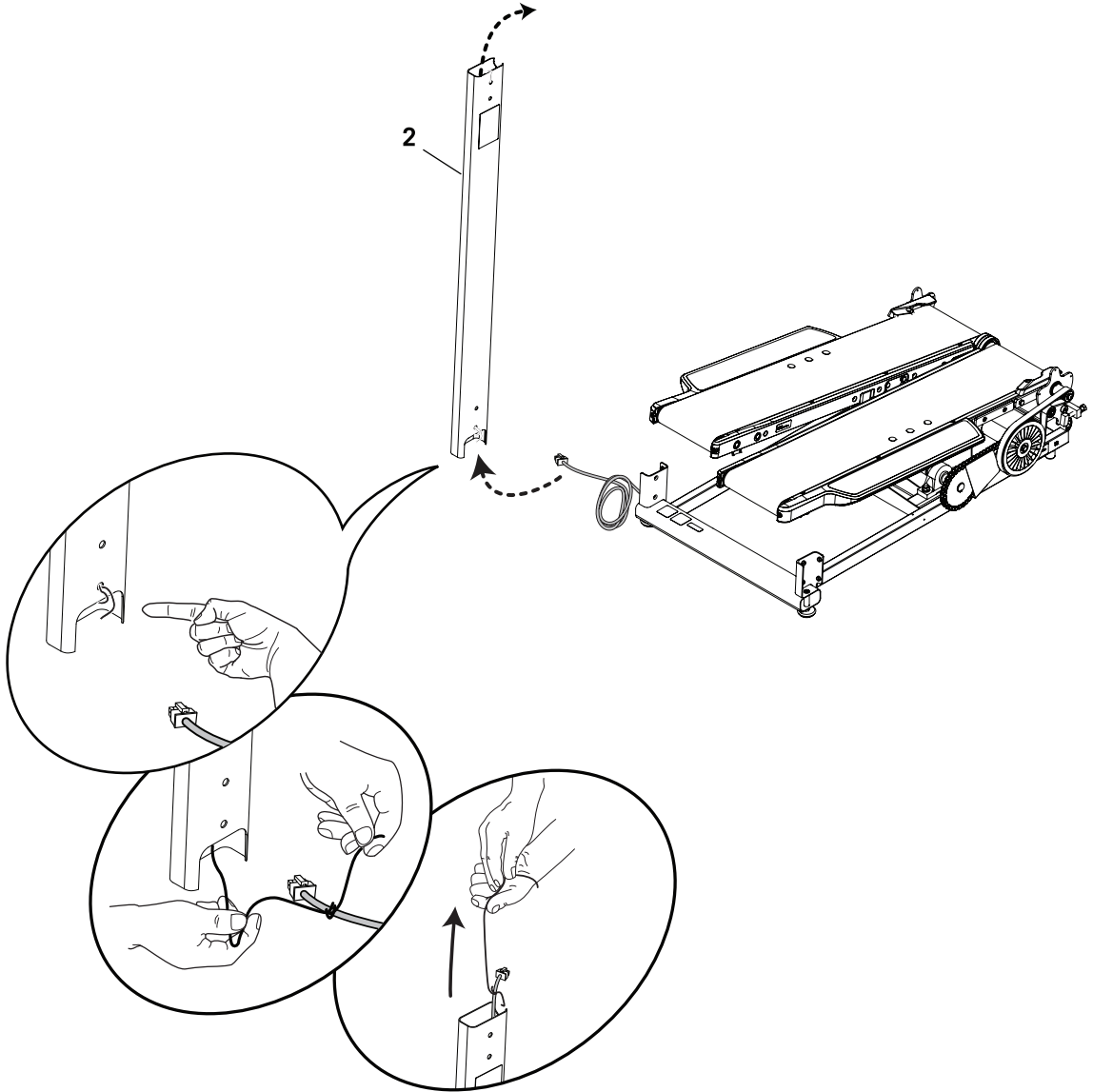

7. Attach the Uprights to the Treadle Assembly

! In order to avoid possible serious injury, when inserting the tube ends into the Treadle Assembly be careful to avoid fingers or hands being caught or pinched.

Note: * Hand tighten this hardware first. Do not crimp the Speed Sensor Cable.

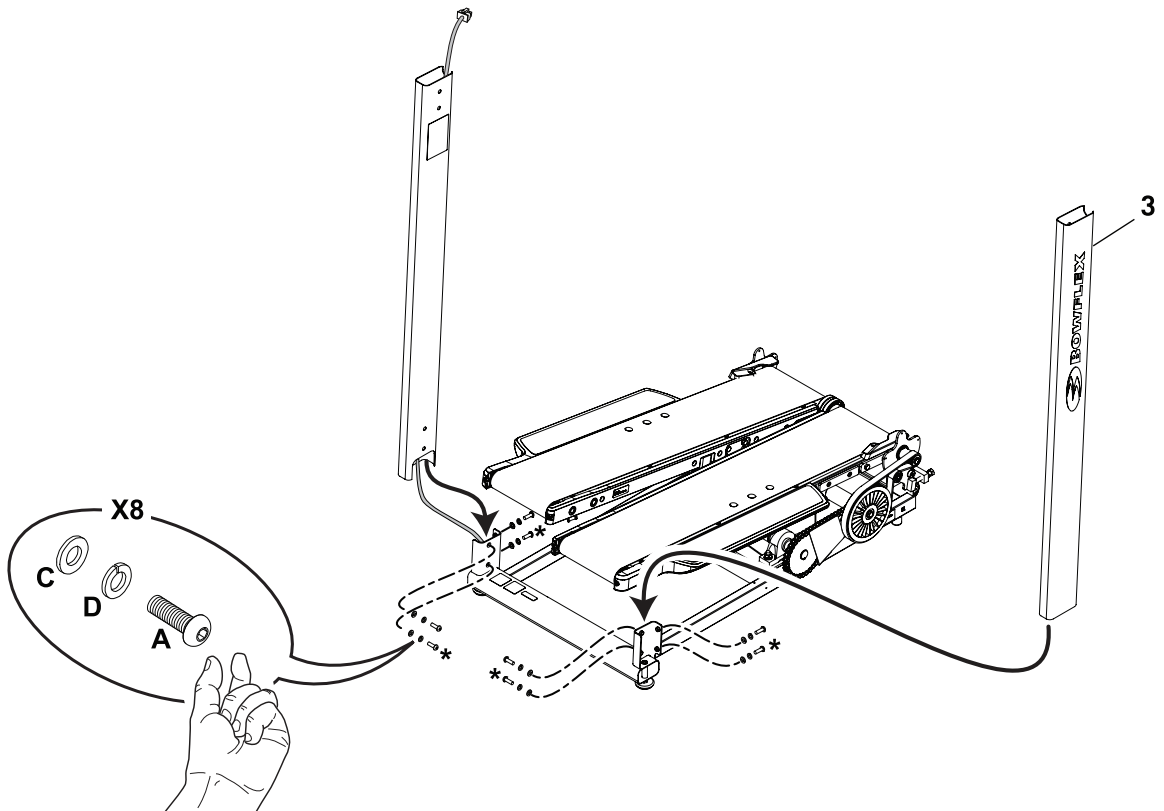

8. Attach the Junction Covers and Console/Handlebar Assembly after routing the Speed Sensor Cable into the Console/ Handlebar Assembly

! In order to avoid possible serious injury, when inserting the tube ends into the Base Assembly be careful to avoid fingers or hands being caught or pinched.

Note: Do not crimp the Speed Sensor Cable. This step may require two people.

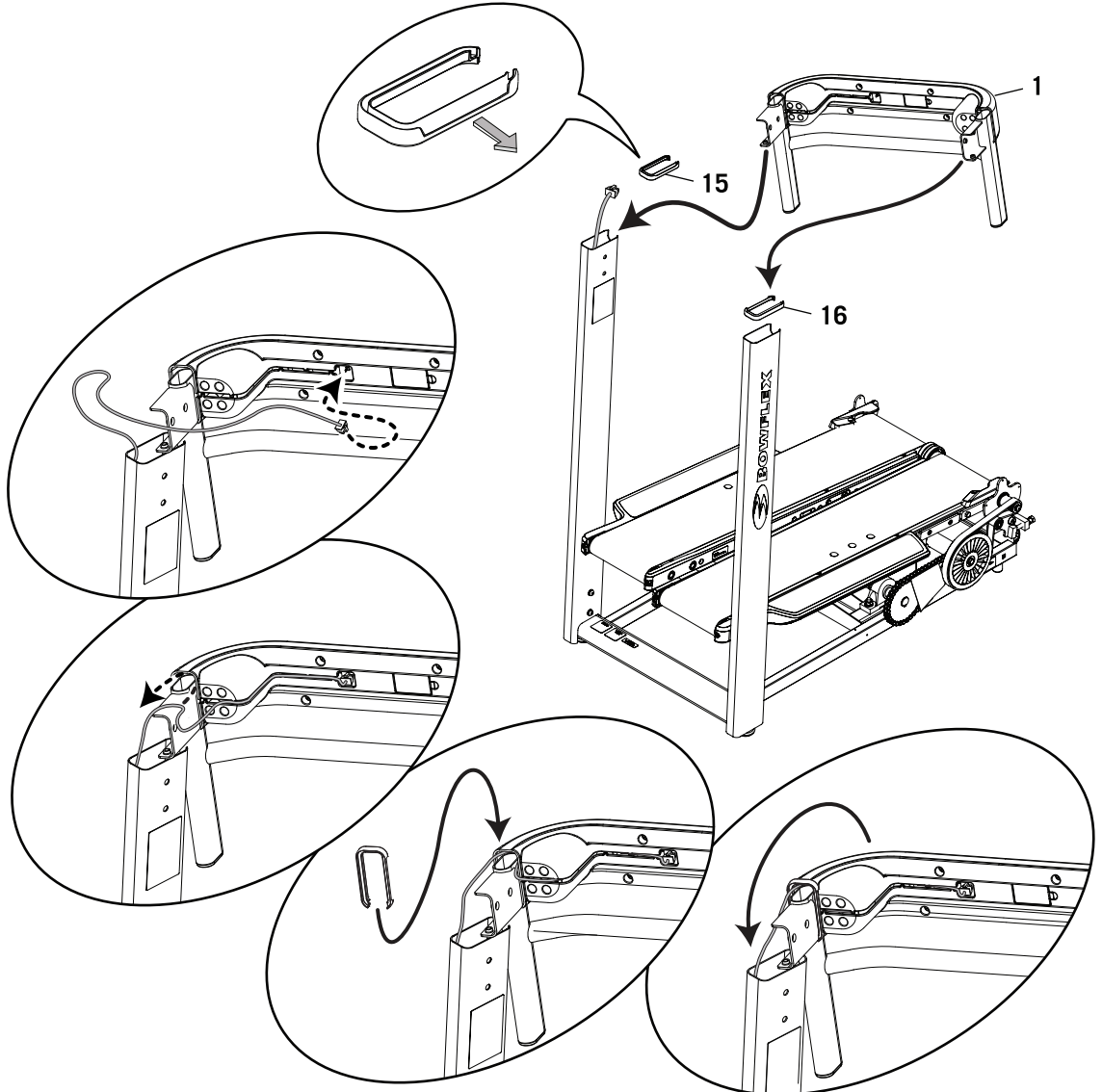

9. Secure the Console/ Handlebar Assembly

Note: * Hand tighten this hardware first until inner bolt holes align.
Once all hardware has been hand tightened, fully tighten ALL hardware from previous steps.

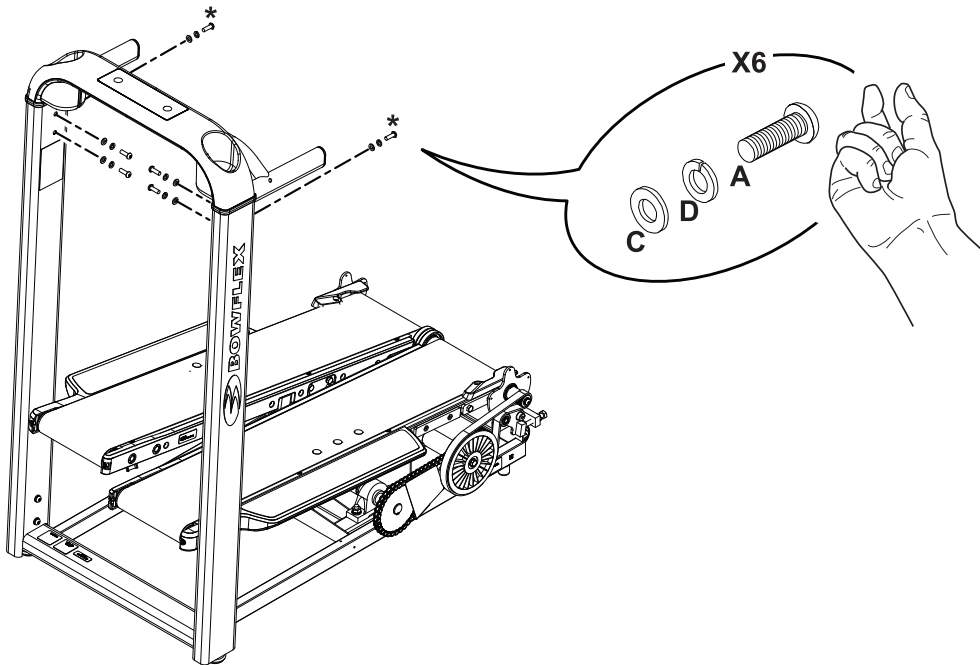

10. Attach the Flywheel Assembly to the Treadle Assembly

Note: Be sure the Speed Sensor Magnet on the Flywheel Assembly is toward the Treadle Assembly. Push and hold the Walking Belt still when tightening the bolt.

! The Walking Belts can abruptly move. To avoid possible serious injury, keep hands away from the edges of the Walking Belts.

Be aware that the Drive Chain and the Walking Belts are connected and when either of these parts move the other does as well. In order to avoid possible serious injury, do not allow anything to be caught or pinched by the Drive Chain when the Walking Belts are moved.

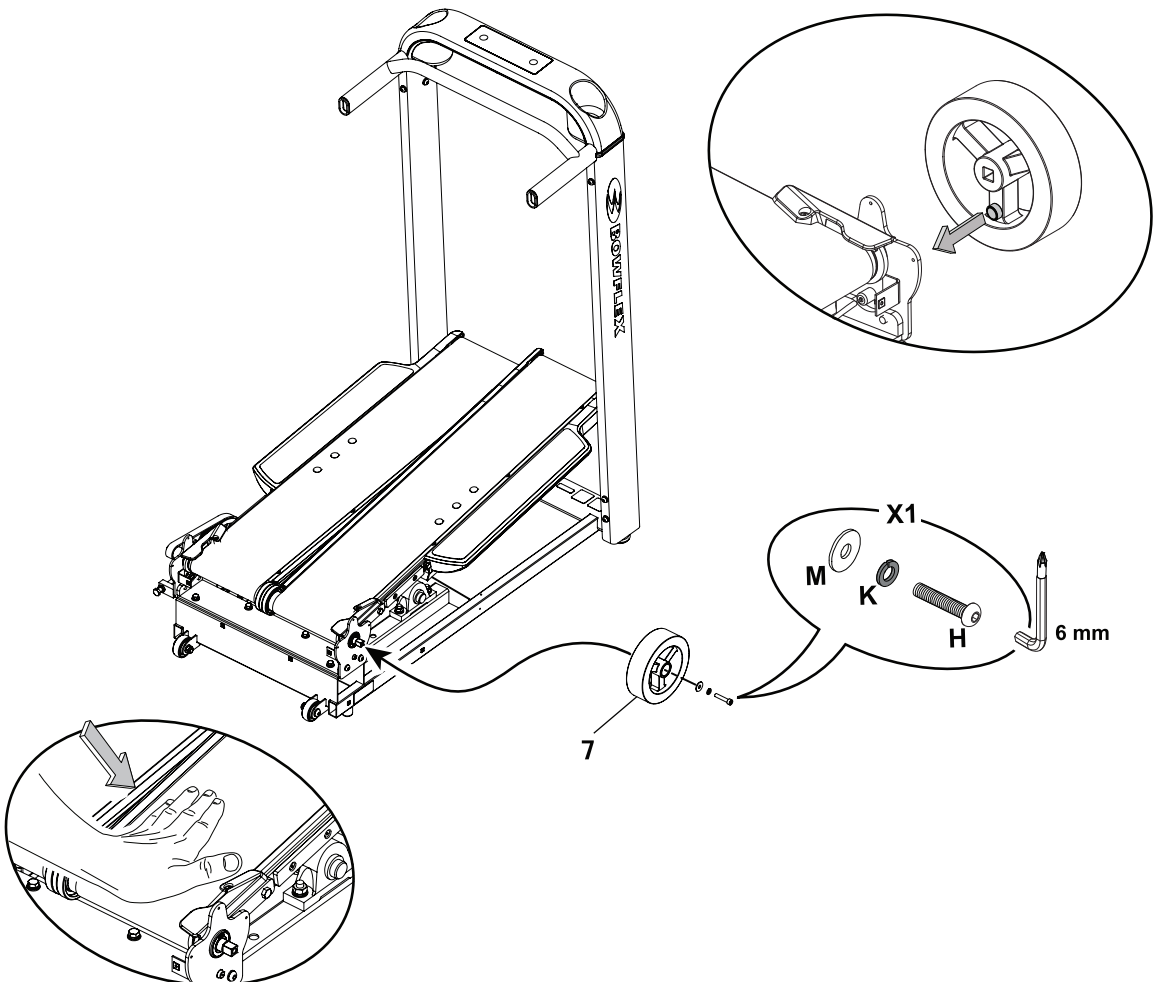

11. Lower a Treadle and Attach the Side Cover to the Treadle Assembly

Completely lower a Treadle by safely pushing the Walking Belt with your foot toward the back of the machine. With the Treadle lowered, tilt the front of the Side Cover downward. Then bring the back of the Side Cover up and over to the Walking Deck, and gently push into position. Do not fully tighten hardware until instructed. Repeat procedure on other side.

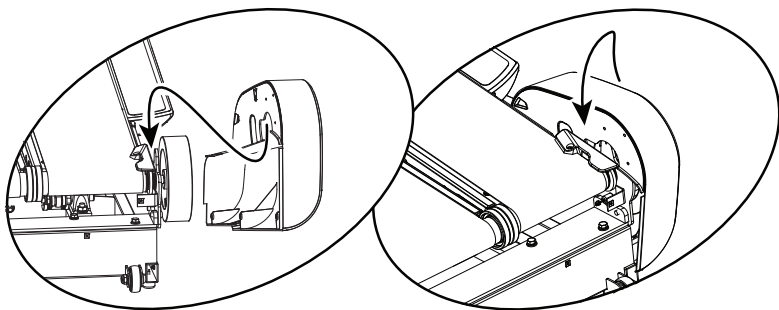
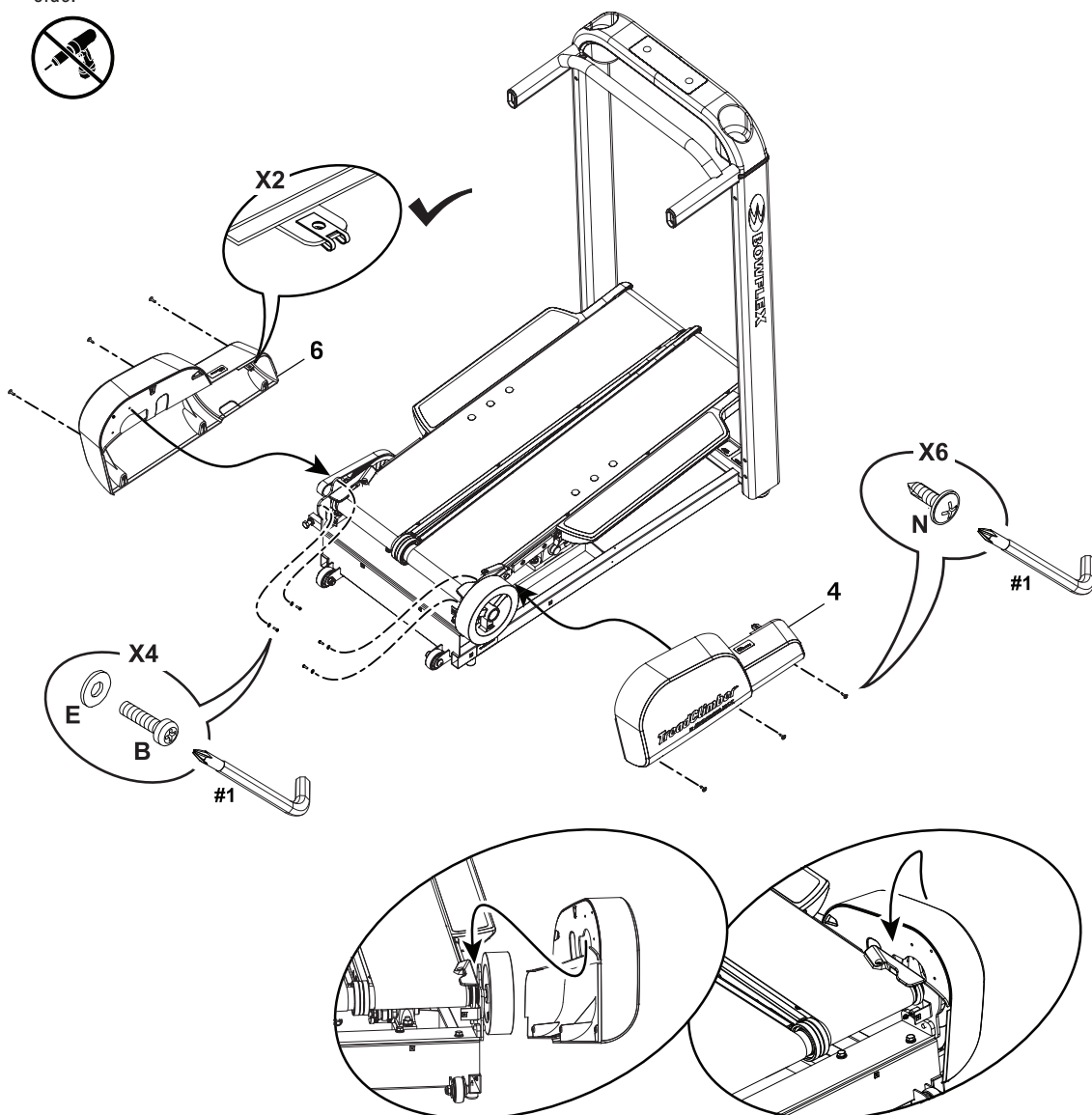

12. Attach the Rear Cover to the Treadle Assembly

Note: Do not fully tighten hardware until instructed.

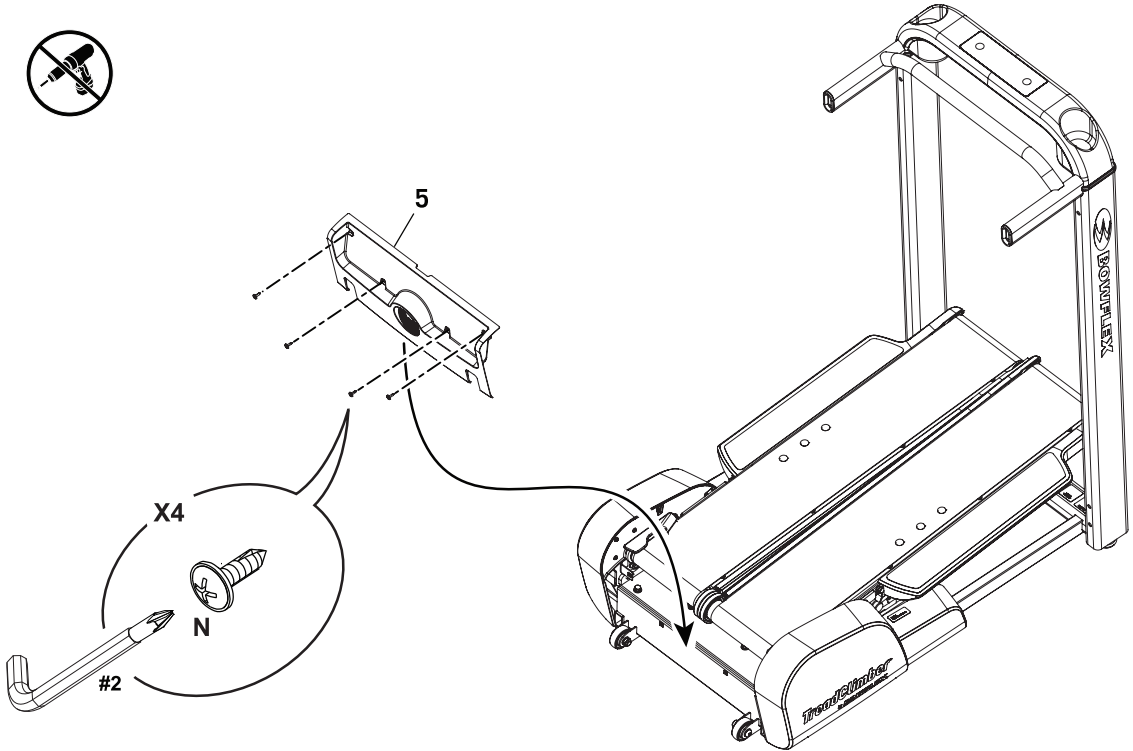

13. Attach the Front Cover to the Treadle Assembly

Note: Adjust the Treadles for additional clearance. Tighten **all** hardware.

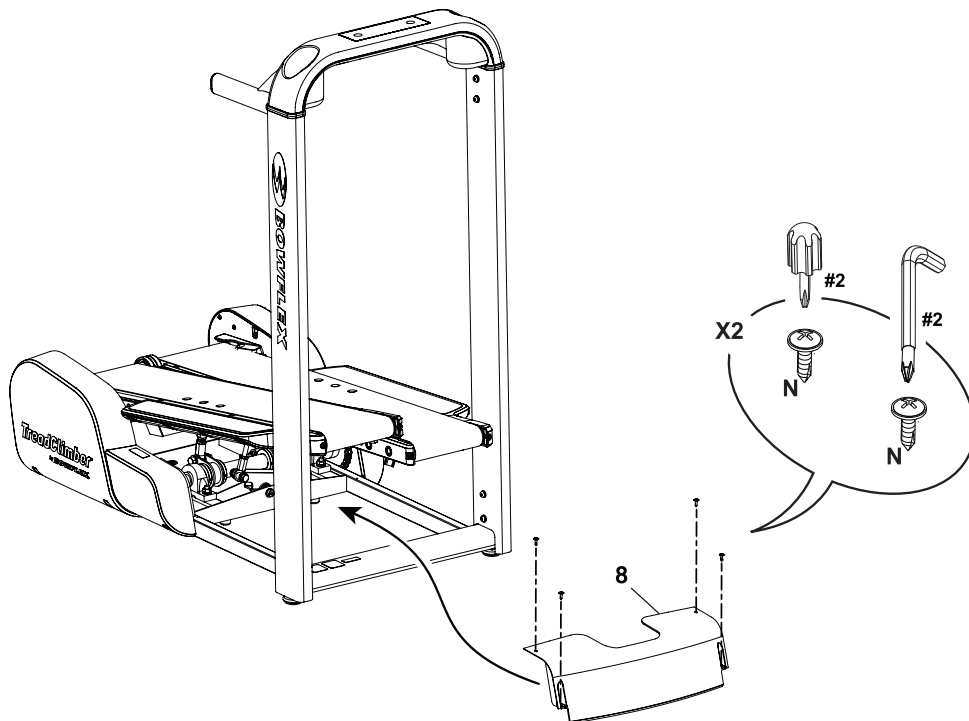

14. Install Batteries into Console/Handlebar Assembly

Note: The console uses 2 AA size batteries (LR6), which are not included. Make sure that the batteries point in the direction of the +/- indicators in the battery bay.



Do not mix old and new batteries.

Do not mix alkaline, standard (carbon-zinc), or rechargeable (Ni-Cd, Ni-MH, etc) batteries.

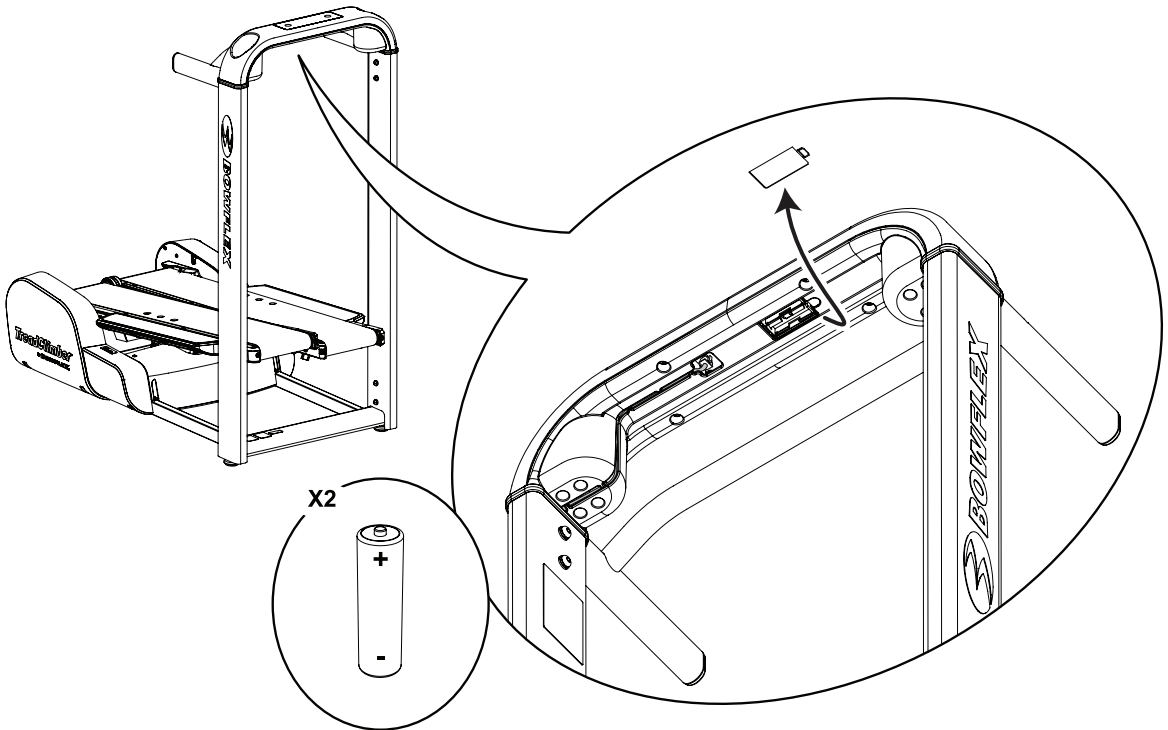

15. Final Inspection

Inspect your machine to ensure that all fasteners are tight and components are properly assembled.



Do not use until the machine has been fully assembled and inspected for correct performance in accordance with the Owner's Manual.

Moving Your Machine

The TreadClimber® fitness machine weighs approximately 163 lbs (74 kg) when fully assembled and requires caution when being moved. Use the Transport Handle Bar found under the front of the machine to move it. To get access to the Transport Handle Bar, turn the Levelers until you have sufficient clearance between the machine and floor.

Your machine can be rolled on the transport wheels to a new location. Lower your machine slowly into its new location without injury to your head or fingers.

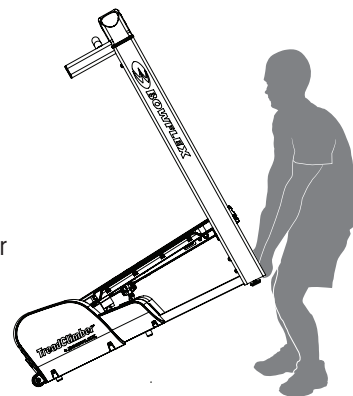

Do not use the uprights, handlebars, treadles, or the Console to lift or move the machine. Injury to you or damage to the machine can occur.

The machine may be moved by one or more persons depending on their physical abilities and capacities. Make sure that you and others are all physically fit and able to move the machine safely.

Place the machine on a clean, hard, level surface, free from unwanted material or other objects that may hamper your ability to move freely. A rubber mat should be used below the machine to prevent the release of static electricity and protect your flooring.

For safe storage of the machine and to prevent unsupervised operation of the machine, always remove the batteries.

Be aware that in the normal operation of the machine, treadle movement is mechanically linked to the walking motion on the belts. When the walk belts are not in motion, the treadles will rest in a fixed position. In the event that an object becomes lodged between the treadles, the treadles can be manually moved in one of the following 2 ways:

- a. Push downward on the outside foot rail of the lowest treadle with your foot or hand, and the treadles will move allowing release of the object.
- b. Push down and back on the walk belt of the lowest treadle with your foot or hand, and the treadles will move allowing release of the object.



Take care not to allow children or pets to play on or around the machine.

Leveling Your Machine

Levelers are found on the front of the TreadClimber® machine. Make sure the TreadClimber® machine is level and stable before you exercise. To adjust:

1. Loosen the upper locking nut.
2. Turn the leveler to adjust the height.
3. Tighten the upper locking nut to lock the leveler.

 Do not adjust the levelers to such a height that they detach or unscrew from the machine. Injury to you or damage to the machine can occur.

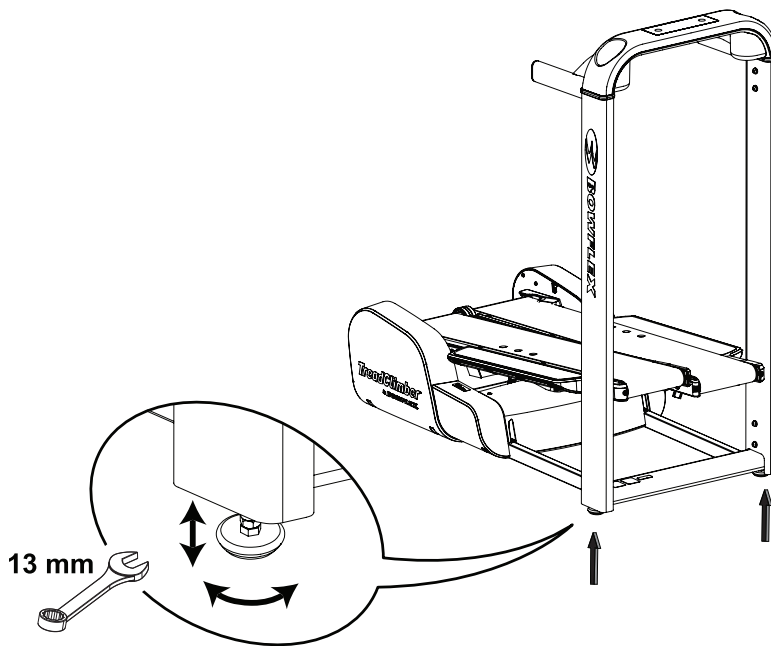



[This page left blank.]



[This page left blank.]



[This page left blank.]

TreadClimber[®]

by **BOWFLEX[®]**

Nautilus[®]

Bowflex[®]

Schwinn[®]

Universal[®]