



PR3000 Home Gym



Assembly Manual

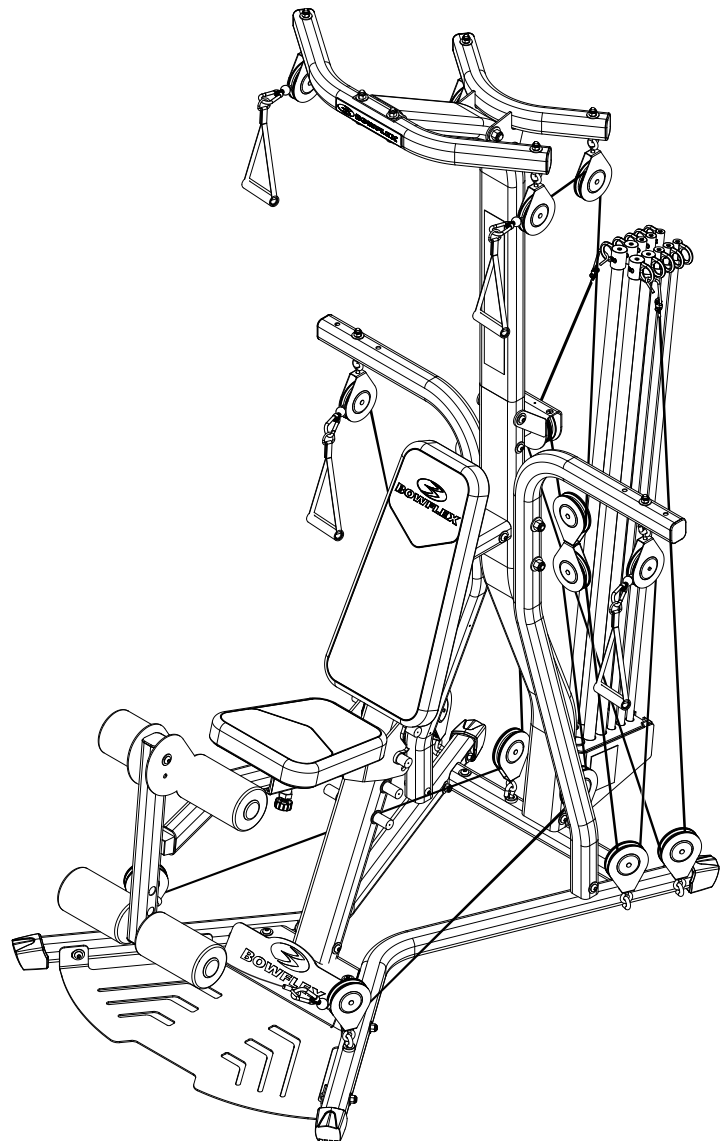

Table of Contents

Before Assembly	2	Attach the Seat Bottom to the Seat Backbone	11
Tools	2	Attach Leg Extension Assembly.....	12
Important Safety Instructions	3	Attach Seat Back.....	13
Hardware	4	Attach the Lat Crossbar with Pulleys	14
Parts	5	Attach the Rear Lat Cross Bar.....	15
Assembly	6	Attach the Upper Lat Tower Assembly	16
Assemble the Base	6	Attach the Lat Pulley Housing	17
Attach the Rod Pack	7	Cable and Pulley Routing	18
Attach the Lower Lat Assembly	8	Connect the Rod Cables	19
Attach the Seat Support Rail	9	Connect the Right Cable	20
Attach Pulley Arms.....	10	Leg Extension Cable Routing	21
		Final Inspection.....	21
		Contacts	23

Before Assembly

Select where you are going to locate your Bowflex® home gym carefully. The best location is on a hard, level surface. For best results, assemble your home gym in the location where you intend to use it. For safe operation, allow a workout area of at least 100" x 78" (2.6m x 2.0m) of free space.

Follow these basic tips to make your assembly quick and easy.

1. Gather all the pieces you need for each step.
2. Turn all the bolts and locknuts toward the right to tighten. Turn towards the left to loosen.
3. Use a combination wrench to grip the locknut when you tighten a bolt that has a locknut to make sure it is tight.
4. All of the tools needed for assembly are included with the unit. You may find the use of a utility knife or scissors beneficial during the unpacking and assembly process.
5. When attaching two pieces, lightly lift and look through the bolt holes to help guide the bolt through the holes.
6. Assembly requires two people.

NOTICE: Leave all of the cables wrapped and bagged until the Bowflex® home gym is completely assembled.

Tools

- (2) Adjustable Wrenches (not included)
- Phillips Head Screwdriver

Important Safety Instructions

 This icon means a potentially hazardous situation which, if not avoided, could result in death or serious injury.











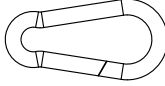
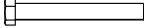
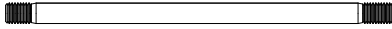

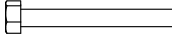

Before using this equipment, obey the following warnings

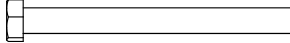
 Read and understand all warnings on this machine.
Carefully read and understand the Assembly Manual.

- Keep bystanders and children away from the product you are assembling at all times.
- Do not assemble equipment in a wet or damp location.
- Make sure assembly is done in an appropriate work space away from foot traffic and exposure to bystanders.
- Some components of the machine can be heavy or awkward. Use a second person when doing the assembly steps involving these parts. Do not do steps that involve heavy lifting or awkward movements on your own.
- Do not try to change the design or functionality of this machine. This could compromise the safety and can void the warranty.
- If replacement parts are necessary use only genuine Nautilus® replacement parts and hardware. Failure to use genuine replacement parts can cause a risk to users, keep the machine from operating correctly or void the warranty.
- Do not use or put the machine into service until the machine has been fully assembled and inspected for correct performance in accordance with the Owner's Manual.

Hardware

(Hardware not actual size)

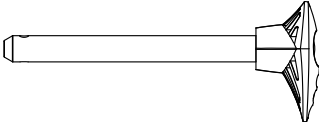
Qty. 19 	Item #1 3/8" x 3/4" Hex Head Bolt	Qty. 6 	Item #10 Snap Hook
Qty. 2 	Item #2 5/16" x 2 1/2" Hex Head Bolt	Qty. 2 	Item #11 1/2" x 9 1/2" Threaded Stud
Qty. 3 	Item #3 1/4" Washer	Qty. 4 	Item #12 Ball Stop
Qty. 4 	Item #4 1/2" Washer	Qty. 2 	Item #13 3/8" x 3" Hex Head Bolt
Qty. 31 	Item #5 3/8" Washer	Qty. 2 	Item #14 1/2" x 5 1/4" Hex Head Bolt
Qty. 3 	Item #6 #10 x 1" Phillips Head Screw	Qty. 4 	Item #15 5/16" x 3/4" Hex Head Bolt
Qty. 6 	Item #7 3/8" Nylock Nut	Qty. 4 	Item #16 3/8" x 2 3/4" Hex Head Bolt
Qty. 4 	Item #8 1/2" Wide Washer	Qty. 6 	Item #17 5/16" Washer
Qty. 6 	Item #9 1/2" Nylock Nut	Qty. 1 	Item #18 Seat Pin

Parts

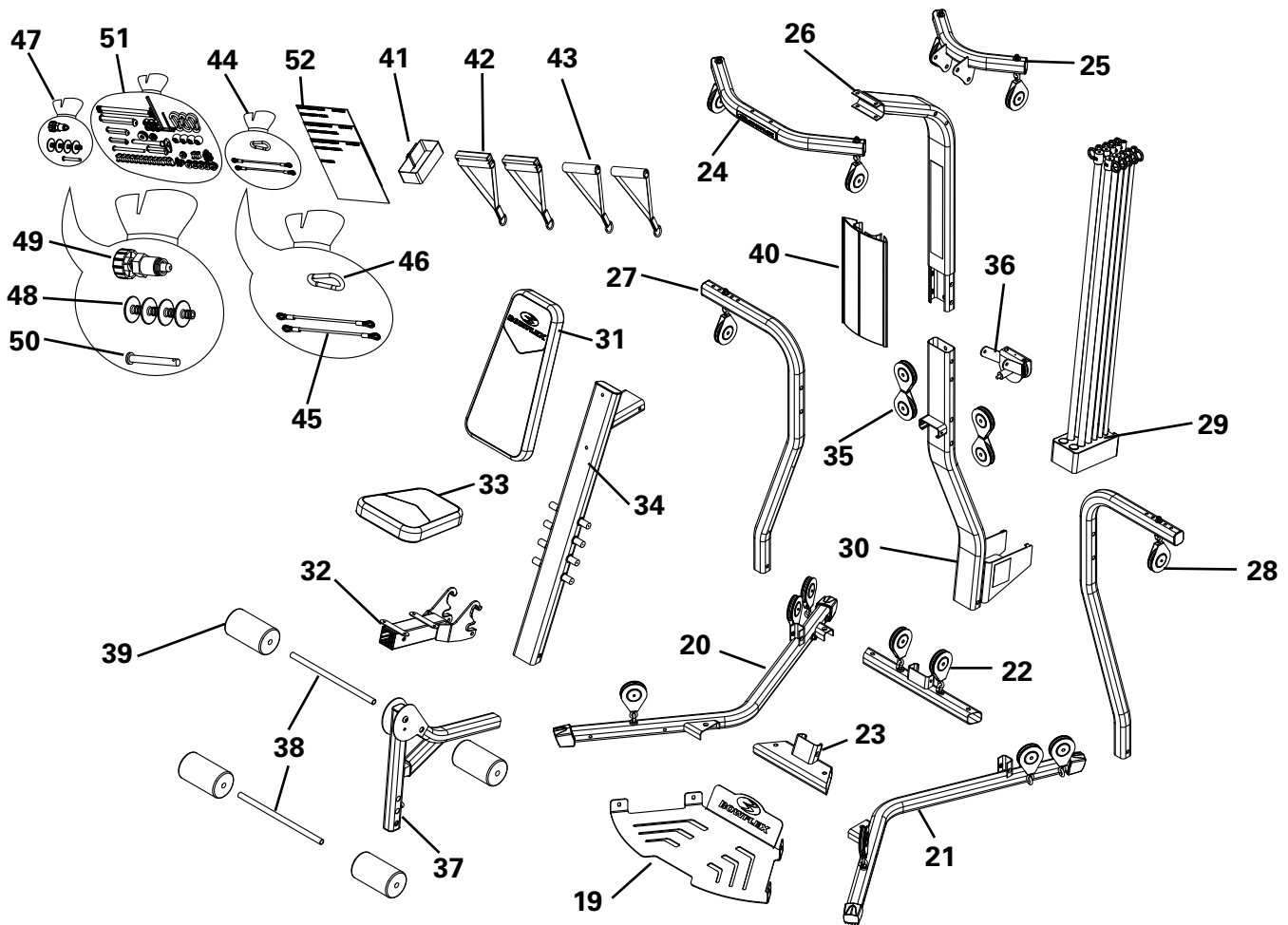

Item #	Qty.	Description
19	1	Base Platform
20	1	Right Frame Rail
21	1	Left Frame Rail
22	1	Rear Cross Bar
23	1	Central Support
24	1	Lat Cross Bar with Pulleys
25	1	Rear Lat Cross Bar
26	1	Upper Lat Tower
27	1	Right Pulley Arm
28	1	Left Pulley Arm
29	1	Rod Pack
30	1	Lower Lat Tower
31	1	Seat Back
32	1	Seat Backbone
33	1	Seat Bottom
34	1	Seat Support Rail
35	2	Floating Pulleys

Item #	Qty.	Description
36	1	Lat Pulley Housing
37	1	Leg Extension Assembly
38	2	Roller Tubes
39	4	Foam Roller Pads
40	1	Placard
41	1	Rod Pack Strap
42	2	Adjustable Handgrips
43	2	Handgrips
44	1	Accessory Bag #1
45	2	Leg Press Extension Cables
46	1	Snap Hook
47	1	Accessory Bag #2
48	4	Roller End Caps
49	1	Leg Extension Lock Pin
50	1	Seat Backbone Lock Pin
51	1	Hardware Bag
52	1	Manual Kit

Assembly

Step 1: Assemble the Base

Parts

- Base Platform (#19)
- Right Frame Rail (#20)
- Left Frame Rail (#21)
- Rear Cross Bar (#22)
- Central Support (#23)

Hardware

- (4) 3/8" x 3/4" Hex Head Bolts (#1)
- (4) 3/8" x 2 3/4" Hex Head Bolts (#16)
- (12) 3/8" Washers (#5)
- (4) 3/8" Nylock Nuts (#7)

Tools

- Adjustable Wrench (not included)

1-1 Put the Base Assembly parts on the floor.

1-2 Align the bolt holes on the Right and Left Frame Rails with the holes in the Base Platform, Rear Cross Bar and the Central Support.

1-3 Install the hardware, but do not tighten the bolts.

1-4 Tighten all hardware.

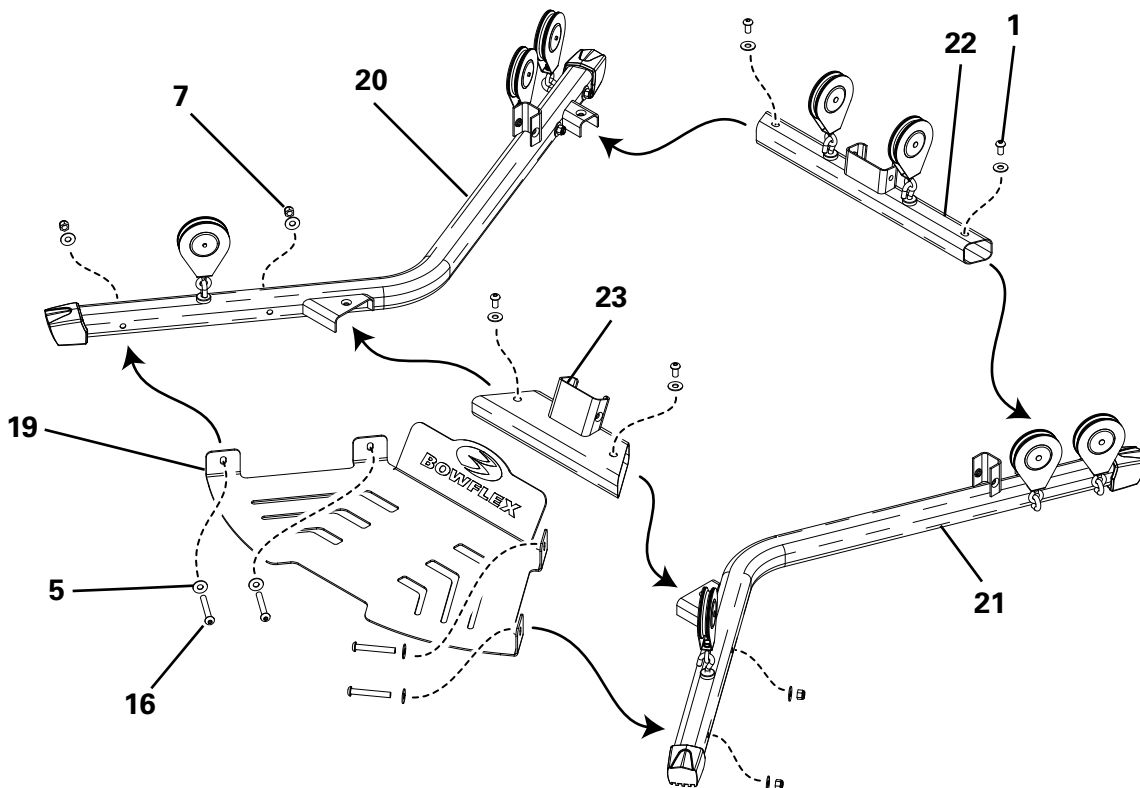

Assembly

Step 2: Attach the Rod Pack

Parts

- Rod Pack (#29)
- Lower Lat Tower (#30)
- Rod Pack Strap (#41)

Hardware

- (3) #10 x 1" Phillips Head Screws (#6)
- (3) 1/4" Washers (#3)

Tools

- Phillips Head Screw Driver (not included)

2-1 Slide the Rod Pack into the Lower Lat Tower.

2-2 Install and tighten the hardware.

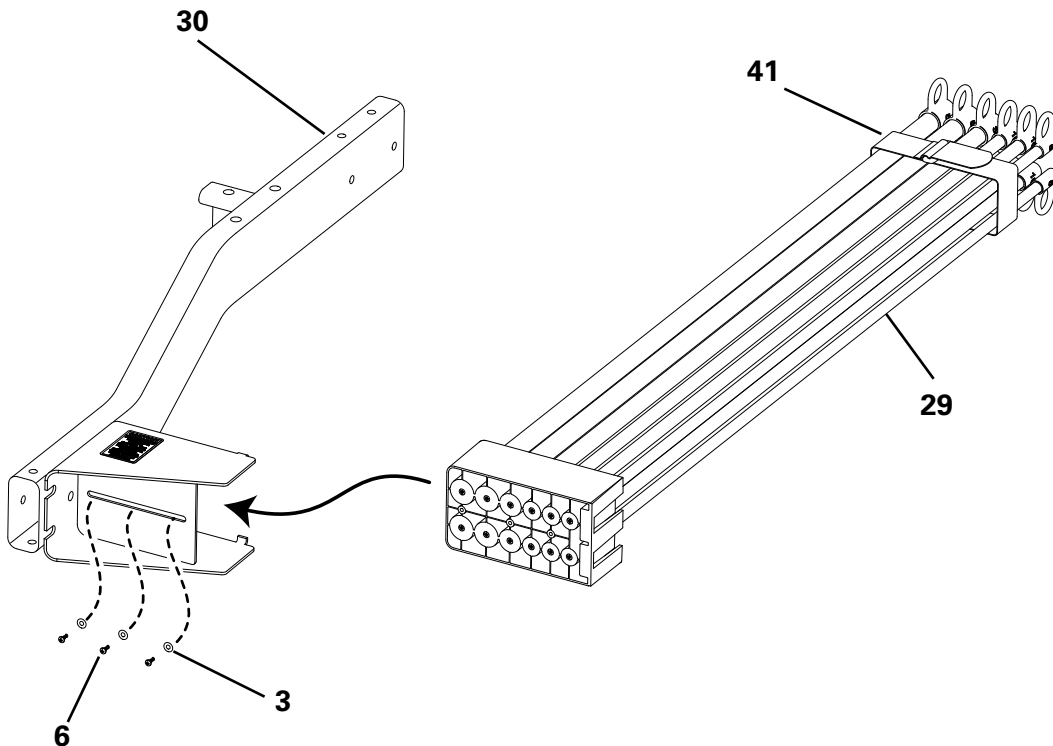

Assembly

Step 3: Attach the Lower Lat Assembly to the Base Assembly

Parts

- Completed Assembly (from step 1)
- Lower Lat Tower Assembly (from step 2)

Hardware

- (2) 3/8" x 3/4" Hex Head Bolts (#1)
- (2) 3/8" Washers (#5)

Tools

- Adjustable Wrench (not included)

3-1 Put the Lower Lat Tower Assembly onto the Completed Assembly.

3-2 Install and tighten the hardware.

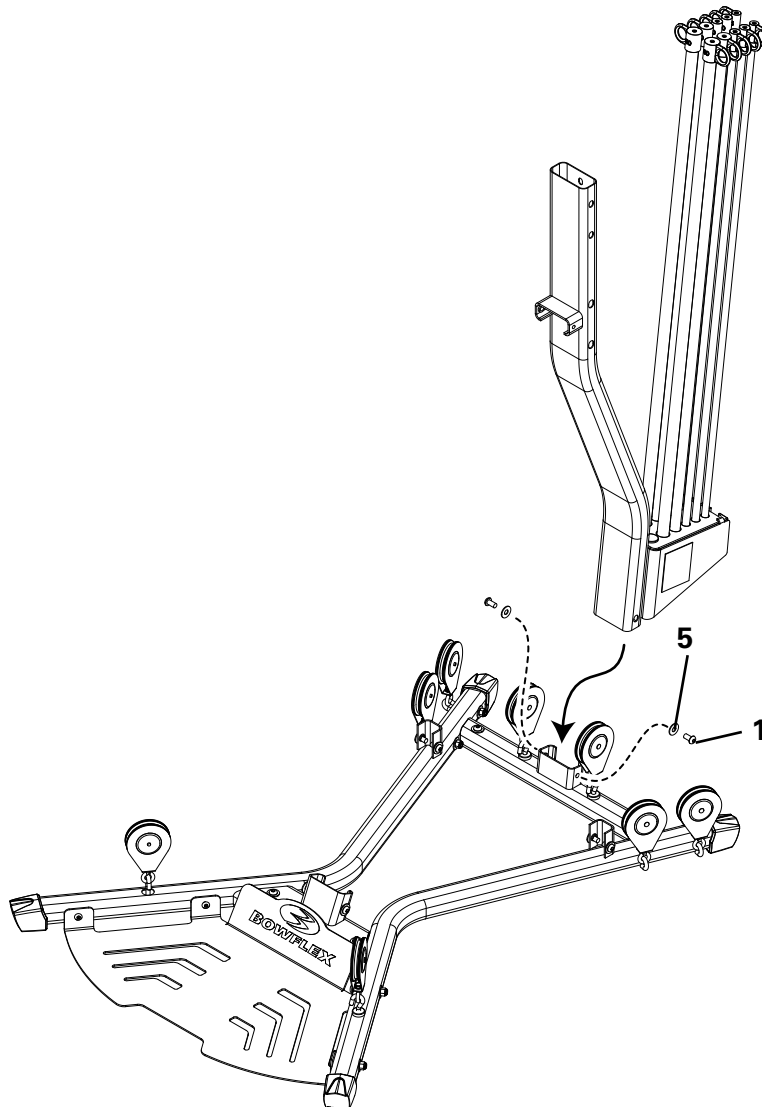

Assembly

Step 4: Attach the Seat Support Rail

Parts

- Seat Support Rail (#34)
- Completed Assembly (from step 3)

Hardware

- (4) 3/8" x 3/4" Hex Head Bolts (#1)
- (4) 3/8" Washers (#5)

Tools

- Adjustable Wrench (not included)

4-1 Attach the Seat Support Rail to the Lower Lat Tower.

4-2 Install and tighten the hardware.

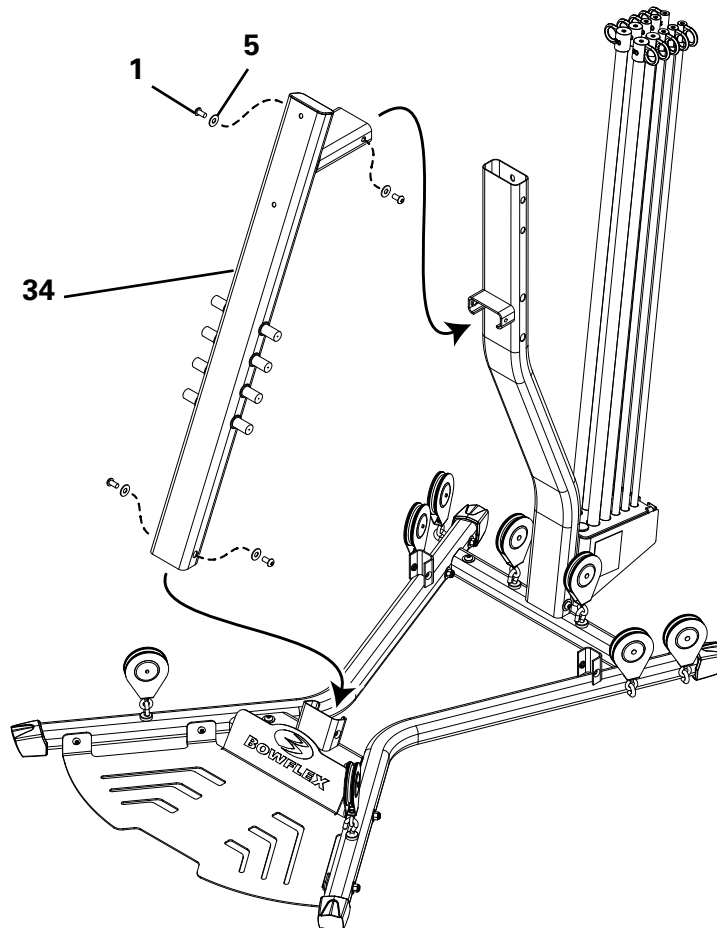

Assembly

Step 5: Attach the Pulley Arms

Parts

- Right Pulley Arm (#27)
- Left Pulley Arm (#28)
- Completed Assembly (from step 4)

Hardware

- (4) 3/8" x 3/4" Hex Head Bolts (#1)
- (4) 3/8" Washers (#5)
- (2) 1/2" x 9 1/2" Threaded Studs (#11)
- (4) 1/2" Wide Washers (#8)
- (4) 1/2" Nylock Nuts (#9)

Tools

- (2) Adjustable Wrenches (not included)

5-1 Attach the the Right and Left Pulley Arms to the Completed Assembly.

5-2 Install and tighten the hardware.

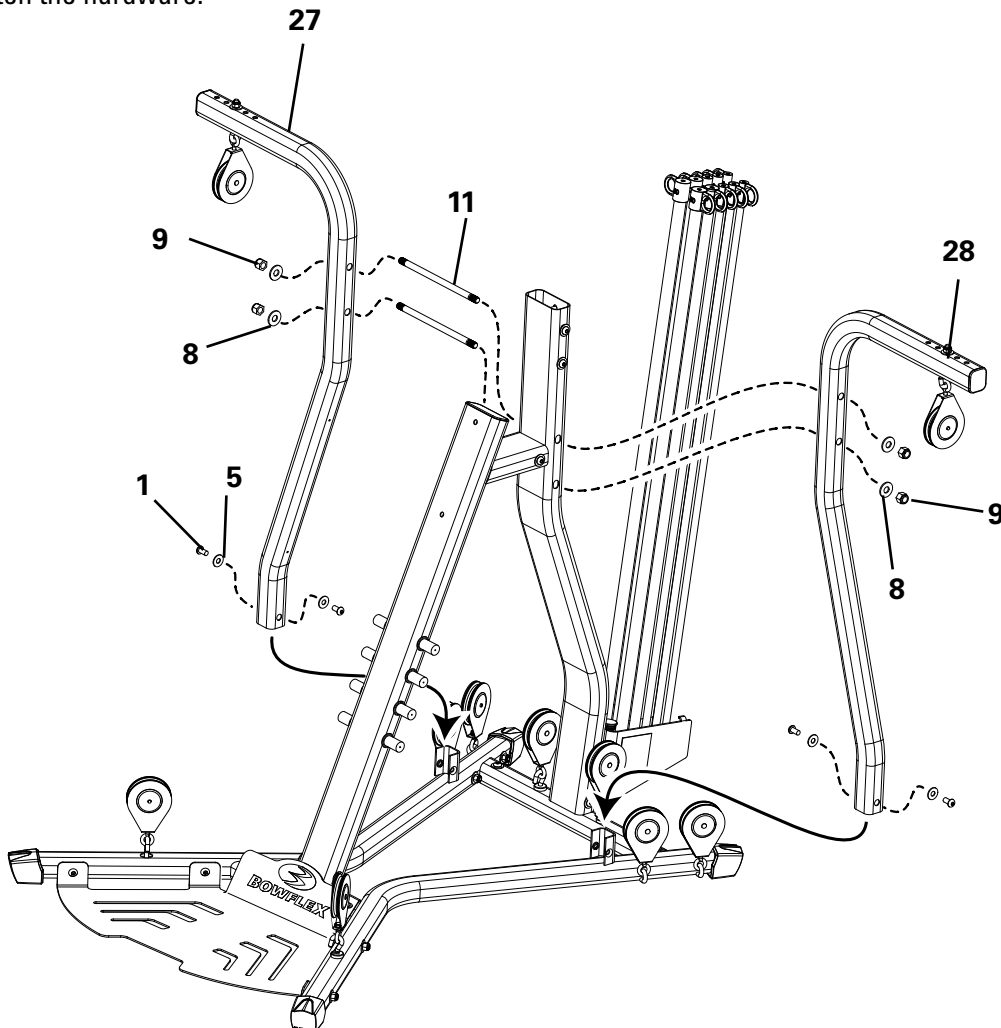

Assembly

Step 6: Attach the Seat Bottom to the Seat Backbone

Parts

- Seat Bottom (#33)
- Seat Backbone (#32)

Hardware

- (4) 5/16" x 3/4" Hex Head Bolts (#15)
- (4) 5/16" Washers (#17)

Tools

- Adjustable Wrench (not included)

6-1 Attach the Seat Bottom to the Seat Backbone.

6-2 Install and tighten the hardware.

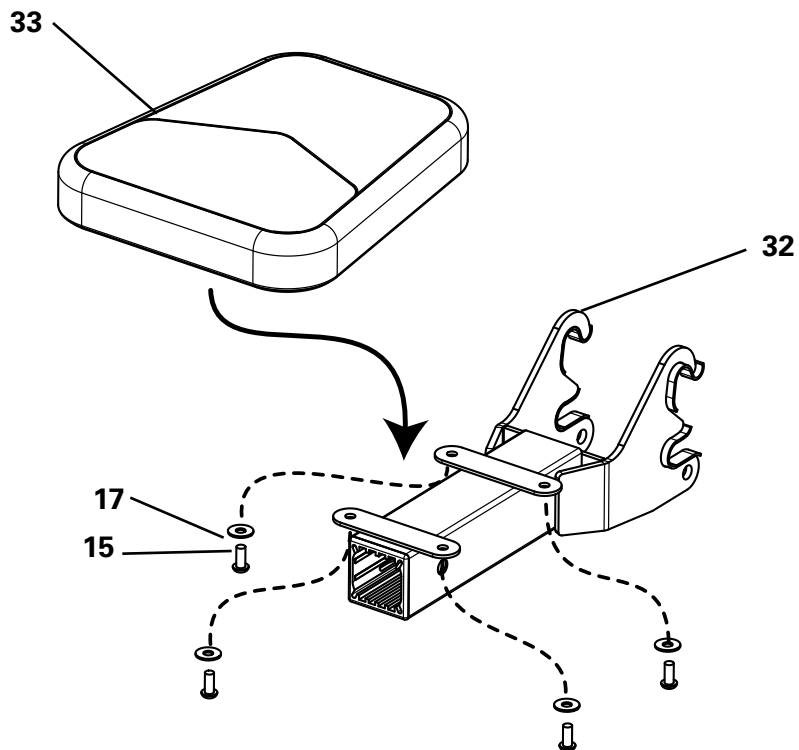

Assembly

Step 7: Attach the Leg Extension Assembly

Parts

- Leg Extension Assembly (#37)
- Leg Extension Lock Pin (#49)
- Seat Bottom Assembly (from step 6)

7-1 Attach the Leg Extension Assembly to the Seat Bottom Assembly with the Leg Extension Lock Pin.

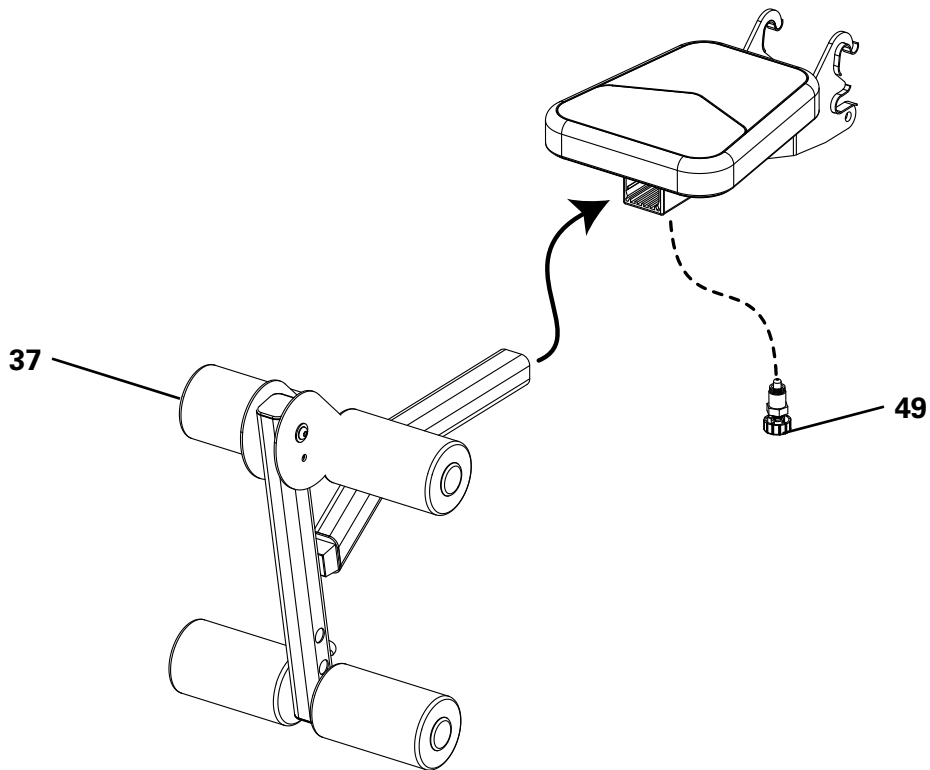

Assembly

Step 8: Attach the Seat Back

Parts

- Seat Back (#31)
- Completed Assembly (from step 5)

Hardware

- (2) 5/16" x 2 1/2" Hex Head Bolts (#2)
- (2) 5/16" Washers (#17)

Tools

- Adjustable Wrench (not included)

8-1 Attach the Seat back to the Seat Support Rail.

8-2 Install and tighten the hardware.

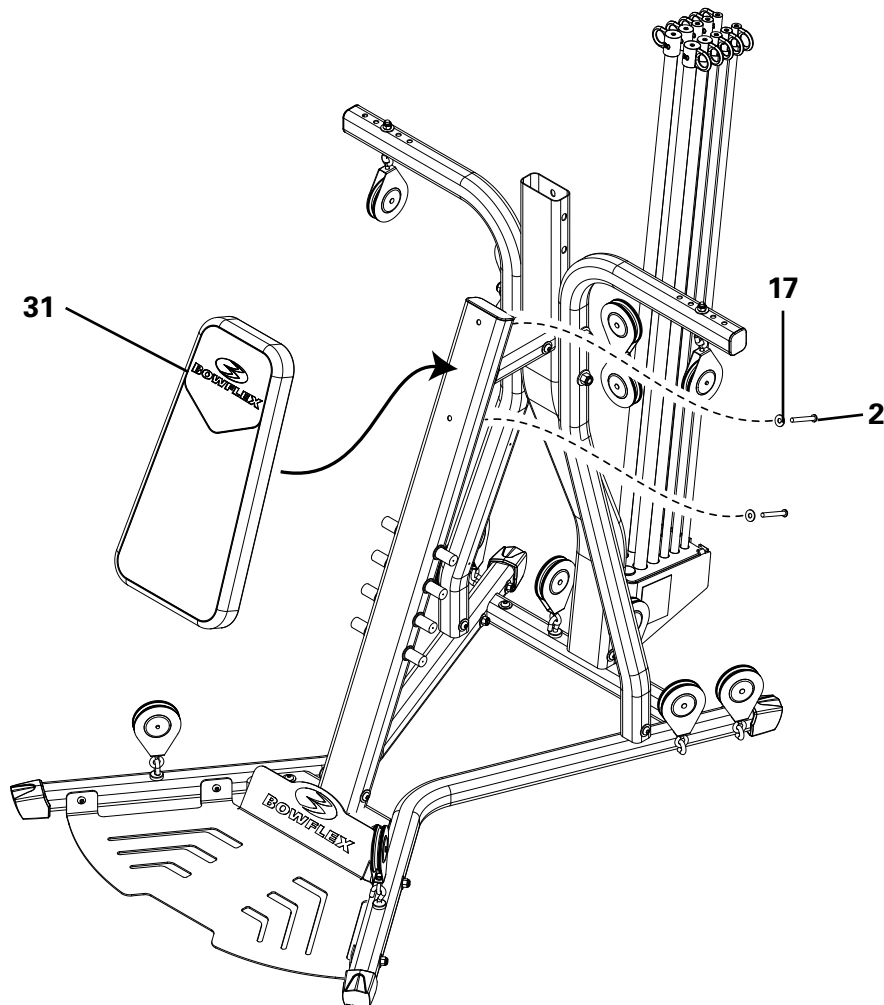

Assembly

Step 9: Attach the Lat Crossbar with Pulleys to the Upper Lat Tower

Parts

- Lat Crossbar with Pulleys (#24)
- Upper Lat Tower (#26)

Hardware

- (2) 3/8" x 3" Hex Head Bolts (#13)
- (4) 3/8" Washers (#5)
- (2) 3/8" Nylock Nuts (#7)

Tools

- (2) Adjustable Wrenches (not included)

9-1 Attach the Lat Crossbar with Pulleys to the Upper Lat Tower.

9-2 Install and tighten the hardware.

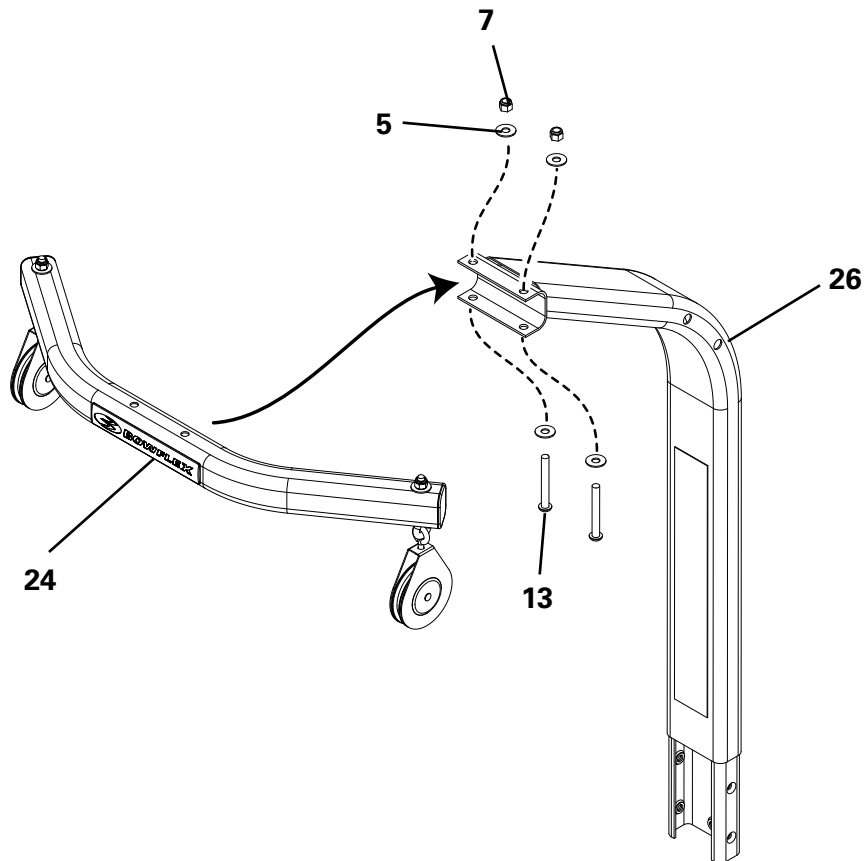

Assembly

Step 10: Attach the Rear Lat Cross Bar

Parts

- Rear Lat Cross Bar (#25)
- Upper Lat Tower Assembly (from step 9)

Hardware

- (2) 1/2" x 5 1/4" Hex Head Bolts (#14)
- (4) 1/2" Washers (#4)
- (2) 1/2" Nylock Nuts (#9)

Tools

- (2) Adjustable Wrenches (not included)

10-1 Attach the Rear Lat Cross Bar to the Upper Lat Tower Assembly.

10-2 Install hardware, but do not tighten.

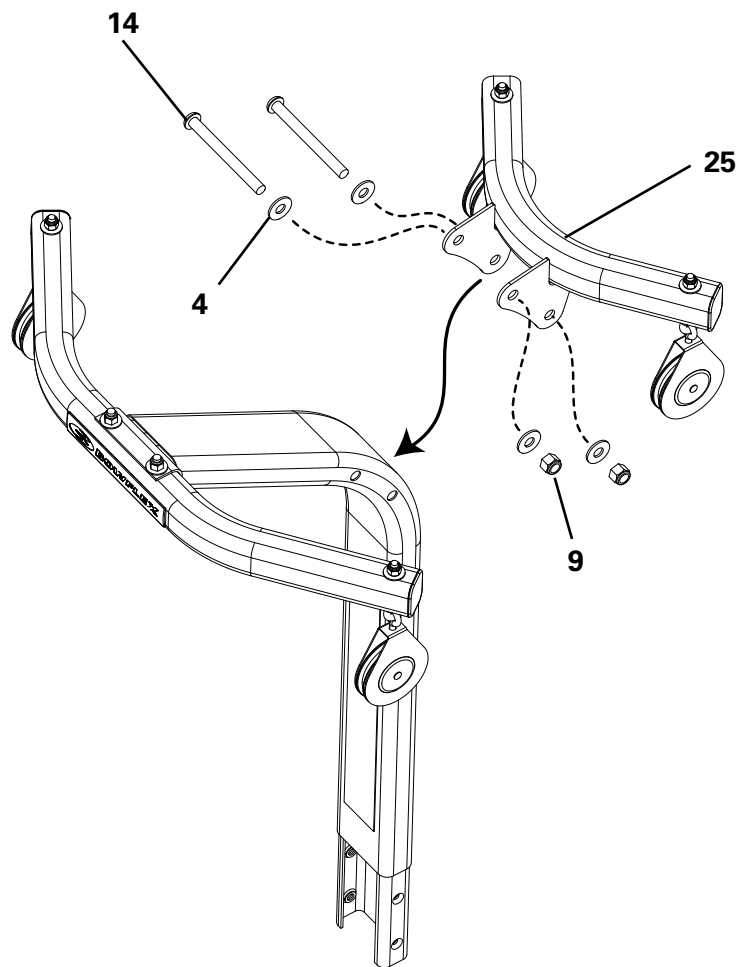

Assembly

Step 11: Attach the Upper Lat Tower Assembly to the Base Assembly

Parts

- Completed Assembly (from step 8)

Hardware

- (2) 3/8" x 3/4" Hex Head Bolts (#1)
- (2) 3/8" Washers (#5)

Tools

- Adjustable Wrench (not included)

11-1 Attach the Upper Lat Tower Assembly to the Base Assembly.

11-2 Install and tighten the hardware.

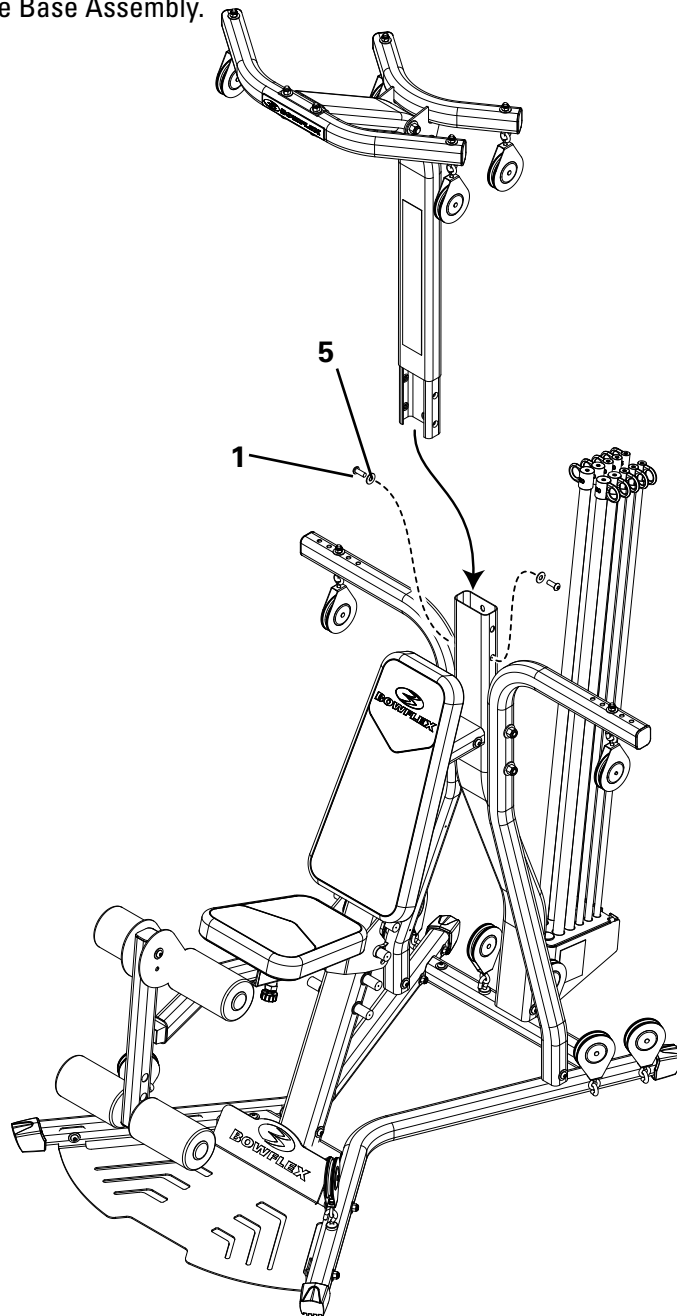

Assembly

Step 12: Attach the Lat Pulley Housing

Parts

- Lat Pulley Housing (#36)
- Completed Assembly (from step 11)

Hardware

- (3) 3/8" x 3/4" Hex Head Bolts (#1)
- (3) 3/8" Washers (#5)

Tools

- Adjustable Wrench (not included)

12-1 Attach the Lat Pulley Housing to the Lat Tower.

Note: Rod Pack removed from illustration for clarity.

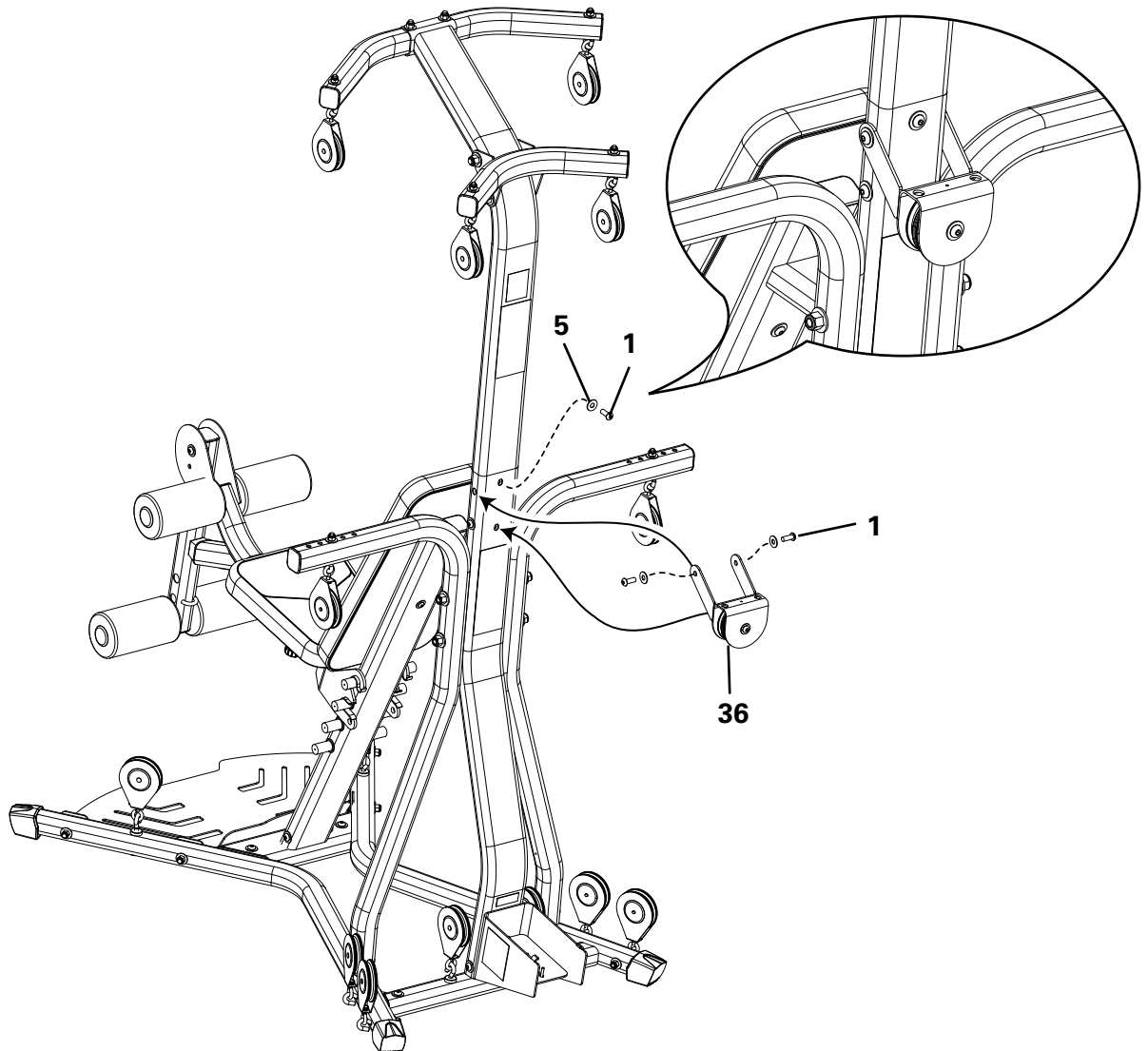

Assembly

Step 13: Cable and Pulley Routing the Rear Pulleys

Parts

- Completed Assembly (from step 12)

Tools

- Adjustable Wrench (not included)

13-1 Remove the 3/8" x 4 1/2" Hex Head Bolt and the 3/8" Washer in the center of the Lat Pulley Housing.

13-2 Remove the two pulley wheels from the Lat Pulley Housing.

13-3 Unwrap the Right Pulley Cable from the Right Frame Rail and thread it under and then over one of the pulley wheels. Pinch the Right Pulley Cable to the pulley wheel until installed.

13-4 Unwrap the Left Pulley Cable on the Left Frame Rail and thread it under and then over the other pulley wheel.

13-5 Put the pulleys with the cables wrapped around them back into the Lat Pulley Housing.

13-6 Replace and tighten the 3/8" x 4 1/2" Hex Head Bolt and the 3/8" Washer in the center of the Lat Pulley Housing.

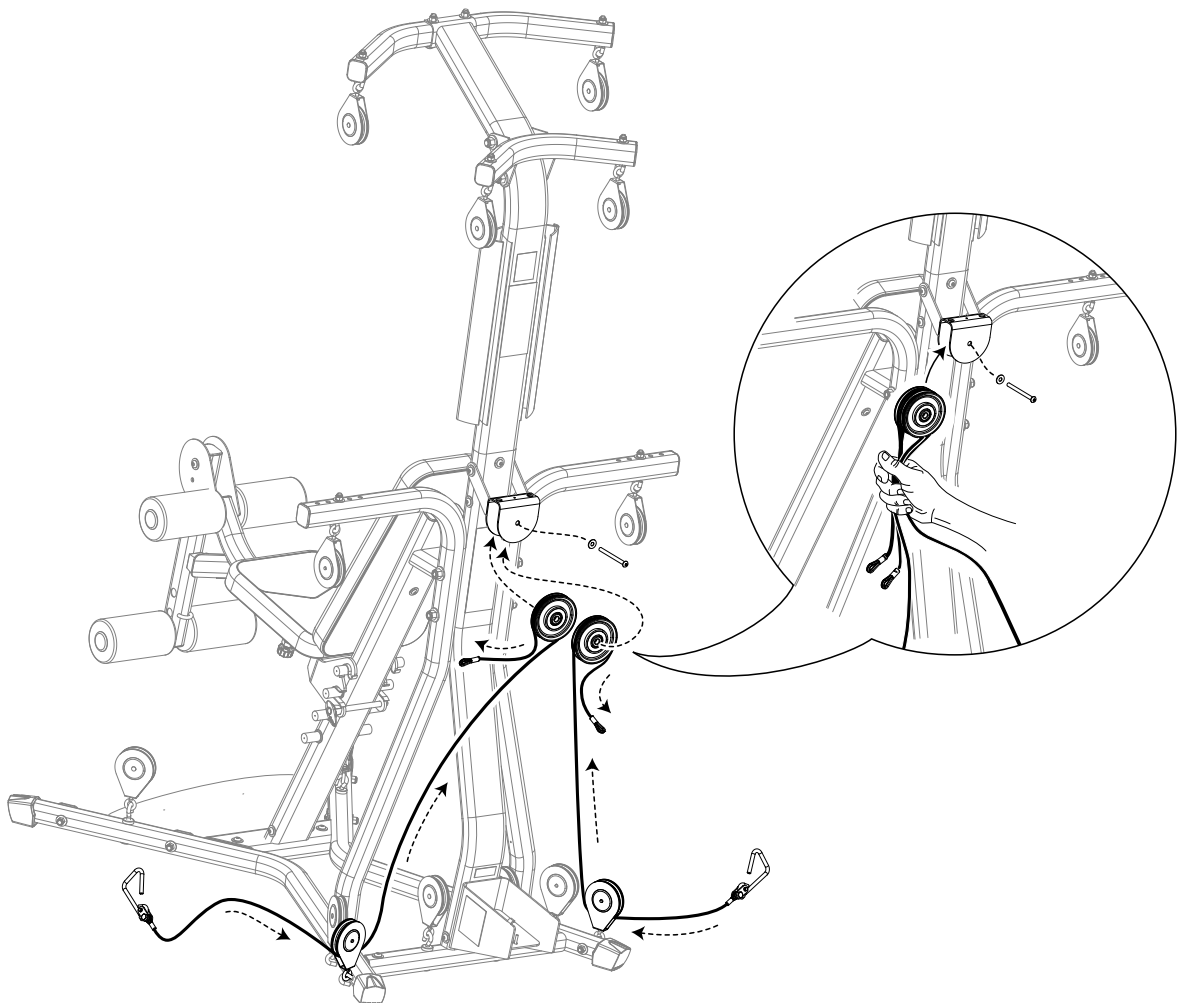

Assembly

Step 14: Connect the Rod Cables through the Right Floating and Lat Tower Pulleys

14-1 Put the right cable that runs through the Lat Pulley Housing through the Floating Pulley (A).

14-2 Pull the same cable through the Pulley on the Rear Lat Cross Bar (B) and then through the Pulley on the Front Lat Cross Bar (C).

14-3 Put the cable end through the Cable End Ball Stop (D).

14-4 Attach the Cable Core (E) to keep the cable from falling out of the pulleys.

14-5 Repeat steps 14-1 through 14-4 on the opposite side.

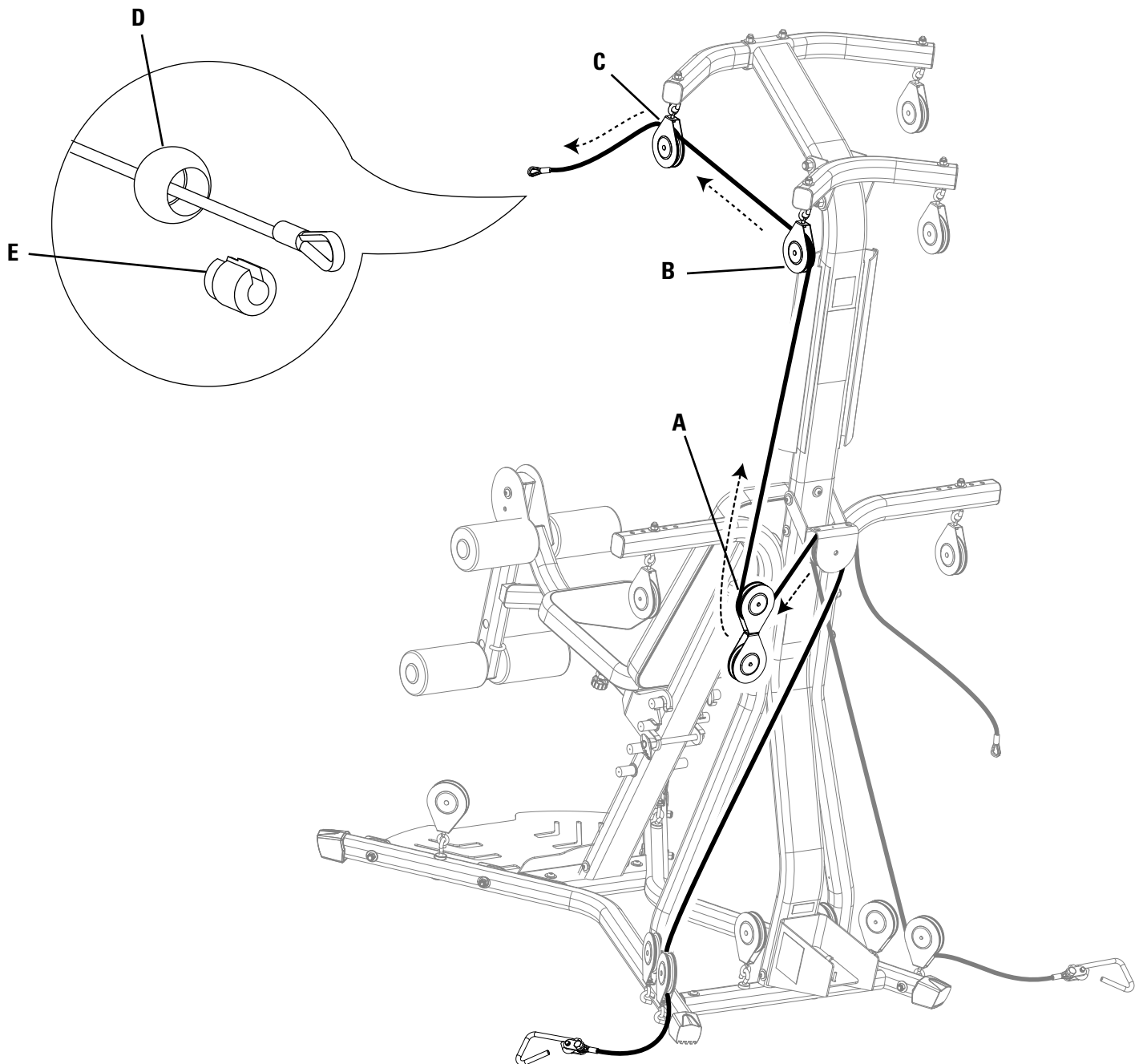

Assembly

Step 15: Connect the Right Squat Cable through the Floating and Main Assembly Pulleys

- 15-1 Unwrap the Right Squat Cable from the Pulley on the front of the Base.
- 15-2 Put the cable under the cable shroud and under and through the Rear Cross Bar Pulley. Follow the arrows.
- 15-3 Put the cable down through the Inner Right Frame Rail Pulley and up through the Right Pulley Arm Pulley.
- 15-4 Put the cable end through the Cable End Ball Stop (A).
- 15-5 Attach the Cable Core (B) to keep the cable from falling out of the pulleys.
- 15-6 Repeat steps 15-1 through 15-5 on the opposite side.

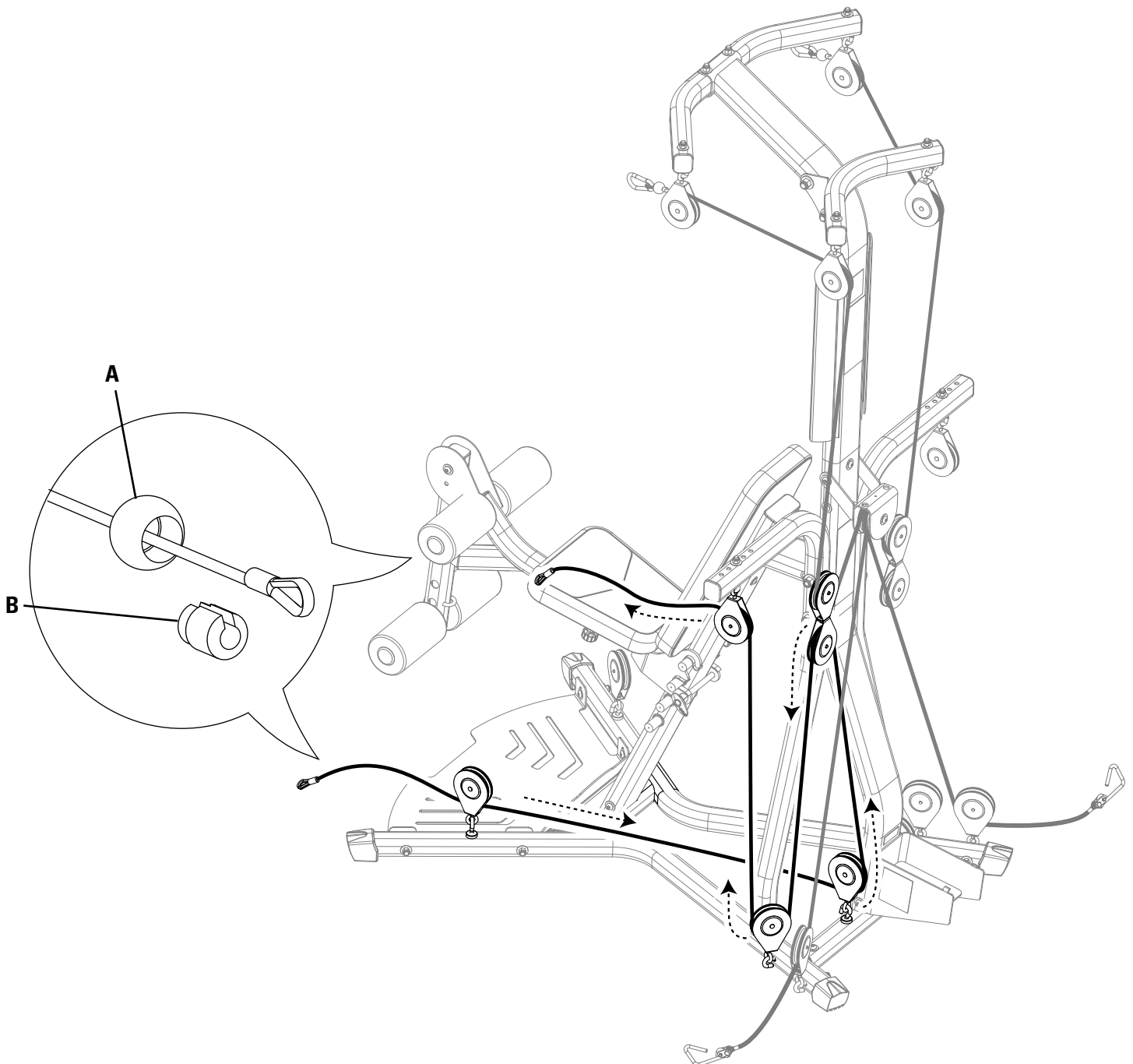

Assembly

Step 16: Leg Press Extension Cable Routing

Parts

- (3) Snap Hooks (#46)
- (2) Leg Press Extension Cables (#45)

16-1 Attach one set of snap hooks onto the left and right squat cables.

16-2 Attach the Leg Press Extension Cables.

16-3 Attach a snap hook to the Leg Extension Assembly and connect the Leg Press Extension Cables.

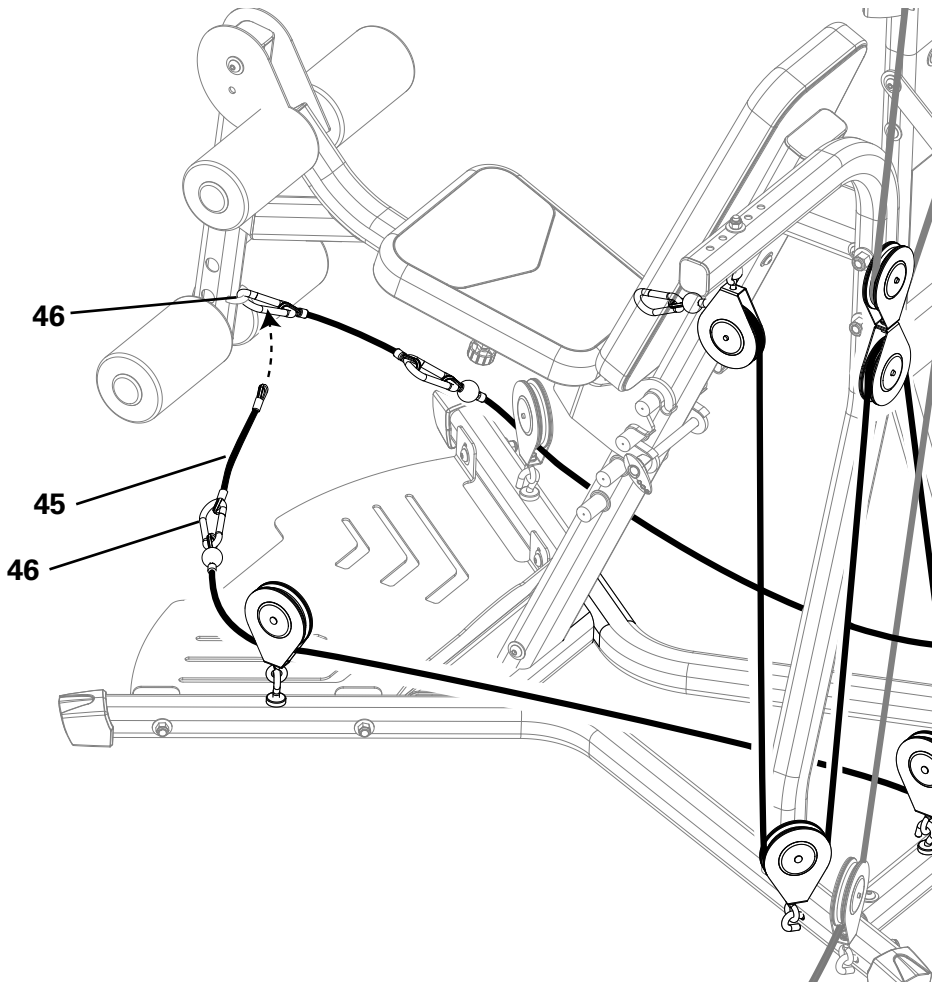

Final Inspection

Inspect your machine to ensure that all fasteners are tight and components are properly assembled.



Failure to visually check and test assembly before use can cause damage to the equipment. It can also cause serious injury to users and bystanders.



Contacts

UNITED STATES

CUSTOMER SERVICE email
customerservice@nautilus.com

TECHNICAL/CUSTOMER SERVICE
Tel: (800) NAUTILUS, (800-628-8458)
Fax: (877) 686-6466
E-mail: cstech@nautilus.com

CORPORATE HEADQUARTERS
Nautilus, Inc.
World Headquarters
16400 SE Nautilus Drive
Vancouver, Washington, USA 98683
Phone: (800) NAUTILUS (800) 628-8458

INTERNATIONAL

For technical assistance and a list of distributors in your area, please call or fax one of the following numbers.

INTERNATIONAL CUSTOMER SERVICE
Nautilus International S.A.
Rue Jean Prouvé
1762 Givisiez / Switzerland
Tel: + 41 26 460 77 77
Fax: + 41 26 460 77 70
E-mail: technics@nautilus.com

GERMANY and AUSTRIA
Nautilus Deutschland GmbH
Albin-Köbis-Str. 4
51147 Köln
Tel: + 49 02203 2020 0
Fax: + 49 02203 2020 45 45

ITALY
Nautilus Italy S.r.l., Via della Mercanzia, 103
40050 Funo di Argelato - Bologna
Tel: + 39 051 664 6201
Fax: + 39 051 664 7461

SWITZERLAND
Nautilus Switzerland SA
Rue Jean-Prouvé 6
CH-1762 Givisiez
Tel: + 41 26 460 77 66
Fax: + 41 26 460 77 60

UNITED KINGDOM
Nautilus UK Ltd
4 Vincent Avenue
Crownhill, Milton Keynes, Bucks, MK8 0AB
Tel: + 44 1908 267 345
Fax: + 44 1908 267 345

CHINA
Nautilus (Shanghai) Fitness Co., Ltd.
7A No.728, Yan'an Road (West)
200050 Shanghai, China
Tel: + 86 21 523 707 00
Fax: + 86 21 523 707 09

Serial Number

Date of Purchase



Printed in China

©2008. Nautilus, Inc. All rights reserved. Nautilus, the Nautilus Logo, Universal, the Universal Logo, Bowflex, the Bowflex logo, Power Rod, StairMaster and Nautilus Institute are either registered trademarks or trademarks of Nautilus, Inc. Schwinn is a registered trademark. All other trademarks are owned by their respective companies. Nautilus, Inc., World Headquarters, 16400 SE Nautilus Drive, Vancouver, WA 98683 1-800-NAUTILUS www.nautilus.com

Nautilus® Bowflex® Schwinn® Fitness StairMaster® Universal® Nautilus Institute®