

AbCoaster[®]

CS 1500



OWNER'S MANUAL & TRAINING GUIDE

Maximum User
Weight is 400 lbs.

CONTENTS

- 3 Important Safety Information
- 4 Assembly Instructions
- 8 Getting On and Off the Ab Coaster®
- 8 Ab Coaster® Exercises
- 9 Adjusting the Seat
- 10 Resistance Training
- 10 Moving, Storing and Maintaining the Ab Coaster®
- 11 Parts List and View

Manufacturer's Limited Warranty – AB COASTER® CS1500

The manufacturer warrants that your Ab Coaster® is free of defects in materials and workmanship and will, at its option, repair or replace any defective Ab Coaster® that is returned to it. All parts and components (including paint) of the Ab Coaster® are warranted for 90 days from the original date of purchase. In addition, the steel frame is warranted for three (3) years from the original date of purchase, and the roller bearings are warranted for one (1) year from the original date of purchase.

This warranty is valid only in accordance with the conditions set forth below:

1. Normal wear and tear are not covered by this warranty.
2. The warranty extends only to the original purchaser and is not transferable. In addition, proof of purchase must be demonstrated.
3. This warranty is void if the product has been subject to accident, misuse, abuse, improper maintenance or repair, or unauthorized modification.
4. This limited warranty is the only written or express warranty given by the manufacturer. Any implied warranty of merchantability or fitness for a particular purpose on this product is limited in duration to the duration of this warranty.
5. Repair or replacement of the product (or, if repair or replacement is not feasible, a refund of the purchase price) is the exclusive remedy under this warranty. The manufacturer shall not be liable for any incidental or consequential damages for breach of this warranty or any implied warranty on this product.

MANUFACTURER MAKES NO WARRANTY OTHER THAN THE WARRANTY SET FORTH HEREIN. SUCH WARRANTY IS IN LIEU OF ALL OTHER WARRANTIES, EXPRESS OR IMPLIED, INCLUDING BUT NOT LIMITED TO ANY IMPLIED WARRANTY OF MERCHANTABILITY OR FITNESS FOR A PARTICULAR PURPOSE.

IMPORTANT SAFETY INFORMATION

IMPORTANT: Please read and follow all instructions thoroughly before using your Ab Coaster®.

- Maximum user weight is 400 lbs.
- ALWAYS USE CAUTION WHEN GETTING ON AND OFF THE Ab Coaster®. READ INSTRUCTIONS ABOUT PROPER WAYS TO GET ON AND OFF THE Ab Coaster®.
- KEEP BODY PARTS, HANDS AND FEET AWAY FROM THE SEAT, WHEELS AND THE CURVED TRACK WHILE USING THE Ab Coaster®. SEVERE INJURY CAN RESULT IF BODY PARTS, HANDS OR FEET ARE PLACED ON TRACK WHILE SOMEONE -IS USING THE UNIT.
- KEEP THE Ab Coaster® OUT OF THE REACH OF CHILDREN. The Ab Coaster® is not a toy and is not meant to be used by or near children and pets. Please keep children and pets away from the Ab Coaster® and during use, as well as when the product is left unattended. If you have children, it is your responsibility to ensure that they do not place any part of their body such as their fingers near the unit while you are exercising.
- Consult your physician before beginning any exercise or diet program, especially if you have concerns about your physical and fitness levels and overall suitability for exercising with the Ab Coaster®.
- If you experience any pain or unusual discomfort during exercising, stop your workout at once and consult a physician before continuing.
- When using the Ab Coaster®, follow the instructions provided in this booklet. Do not use the product for any other exercises or motions which are not contained herein.
- ONLY USE THE Ab Coaster® ON A FLAT, STABLE SURFACE. DO NOT USE THE Ab Coaster® ON A SMALL AREA RUG THAT MAY TEND TO MOVE WHILE EXERCISING.
- DO NOT ATTEMPT TO USE THE Ab Coaster® WITHOUT RESTING YOUR ARMS ON THE ARM REST AND HOLDING ONTO THE HANDLES.
- Do not pick up the Ab Coaster® to move it. Follow the instructions in this booklet for moving the Ab Coaster®.
- Do not leave the Ab Coaster® in the direct sun for extended periods of time.
- Use only accessories and attachments recommended by the manufacturer. Use of any other attachments or accessories not recommended by the manufacturer will void the warranty and could possibly cause serious personal injury or damage to you and the unit.
- Always choose the proper workout level which best suits your physical strength and flexibility.
- Know your limits and train within them. Always use common sense when exercising. If you have any questions regarding your exercise program, please see your physician.
- DO NOT USE THE Ab Coaster® if it is damaged in any manner. Inspect before each use. Failure to observe this warning could result in personal injury while exercising.
- Use the machine only for intended use as described herein. DO NOT modify the machine.
- Do not replace any parts with parts from other equipment or other manufacturers. Use only parts provided by the manufacturer.
- This product is intended for residential and light institutional use only (eg, personal training studios, hotel fitness centers, and fitness facilities under 4000 square feet).

SAVE THESE INSTRUCTIONS AND ENSURE THAT OTHER EXERCISERS READ THESE INSTRUCTIONS PRIOR TO USING THE AB COASTER® FOR THE FIRST TIME.

ASSEMBLY INSTRUCTIONS

Your Ab Coaster® has been thoroughly inspected and partly assembled before shipment. You will need to take a few additional steps as described below to complete assembly. If you have any questions, please call our customer service center at 908-879-2713.

Step 1: Attach Rear Foot

Step 2: Attach Front Foot

Step 3: Attach Front Post

Step 4: Attach Armrest Console

Step 5: Attach Hand Grip to Arm Rest Console

Step 6: Tighten All Bolts and Screws; Adjust Levelers

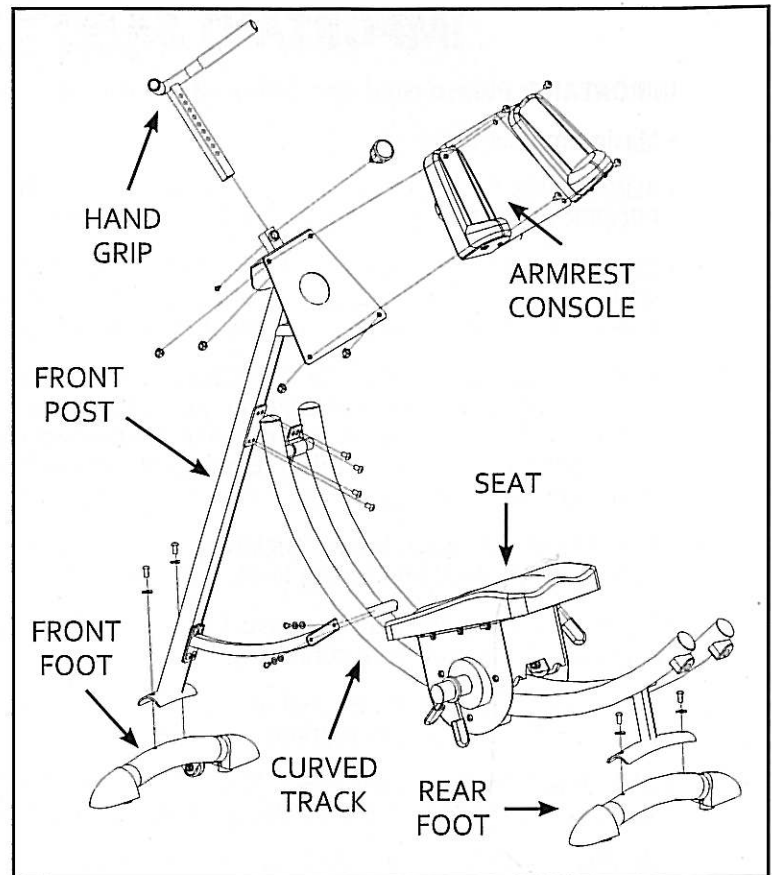

IMPORTANT: Remove all parts from packing and inspect for damage. Retain packing materials if possible.

STEP 1: Attach rear foot (without wheels) to rear of curved track. Do not completely tighten bolts with tool until unit is fully assembled. Use the 2 bolts in package marked for Step 1.

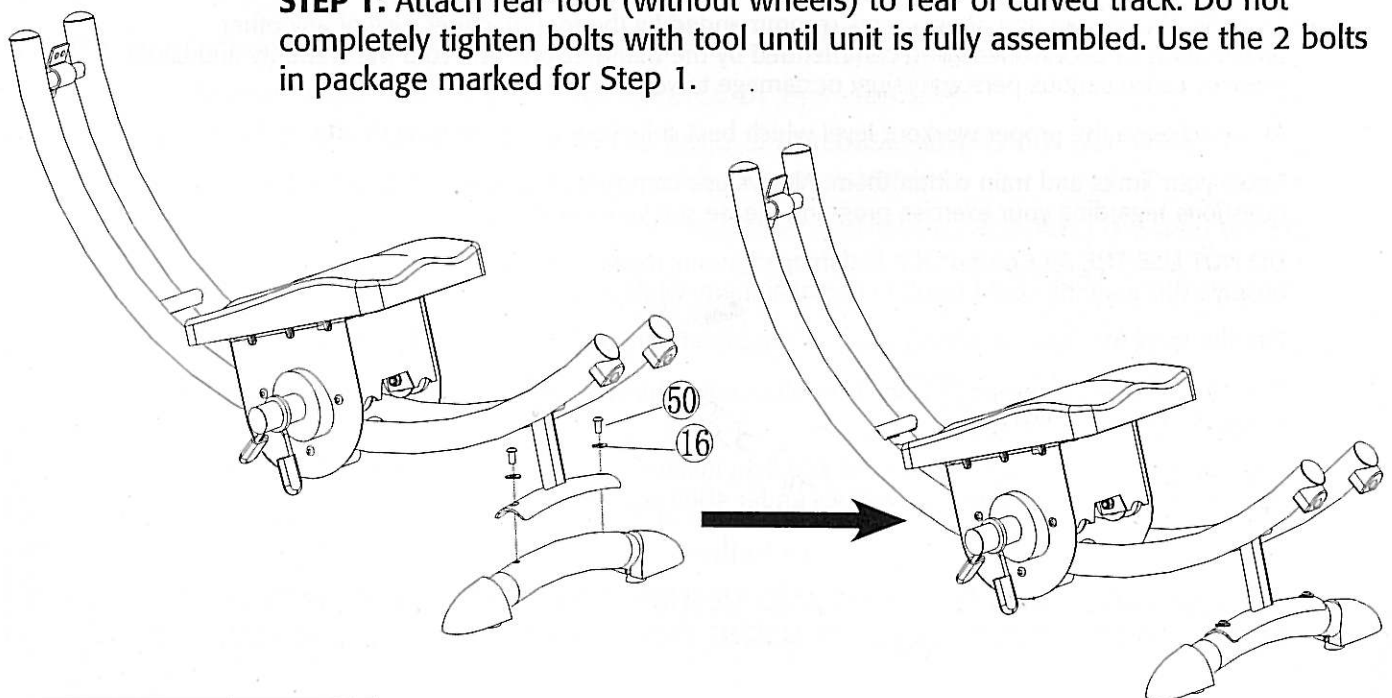

CAUTION: DO NOT CUT!
DO NOT cut and remove this plastic strap until unit is completely assembled.

CAUTION: Do not cut and remove the plastic strap with this label attached until unit is completely assembled. The strap keeps the SEAT secure to the CURVED TRACK for easy assembly.

STEP 2: Attach front foot (with wheels) to front post using the 2 bolts in package marked for Step 2. Do not completely tighten bolts with tool until unit is fully assembled.

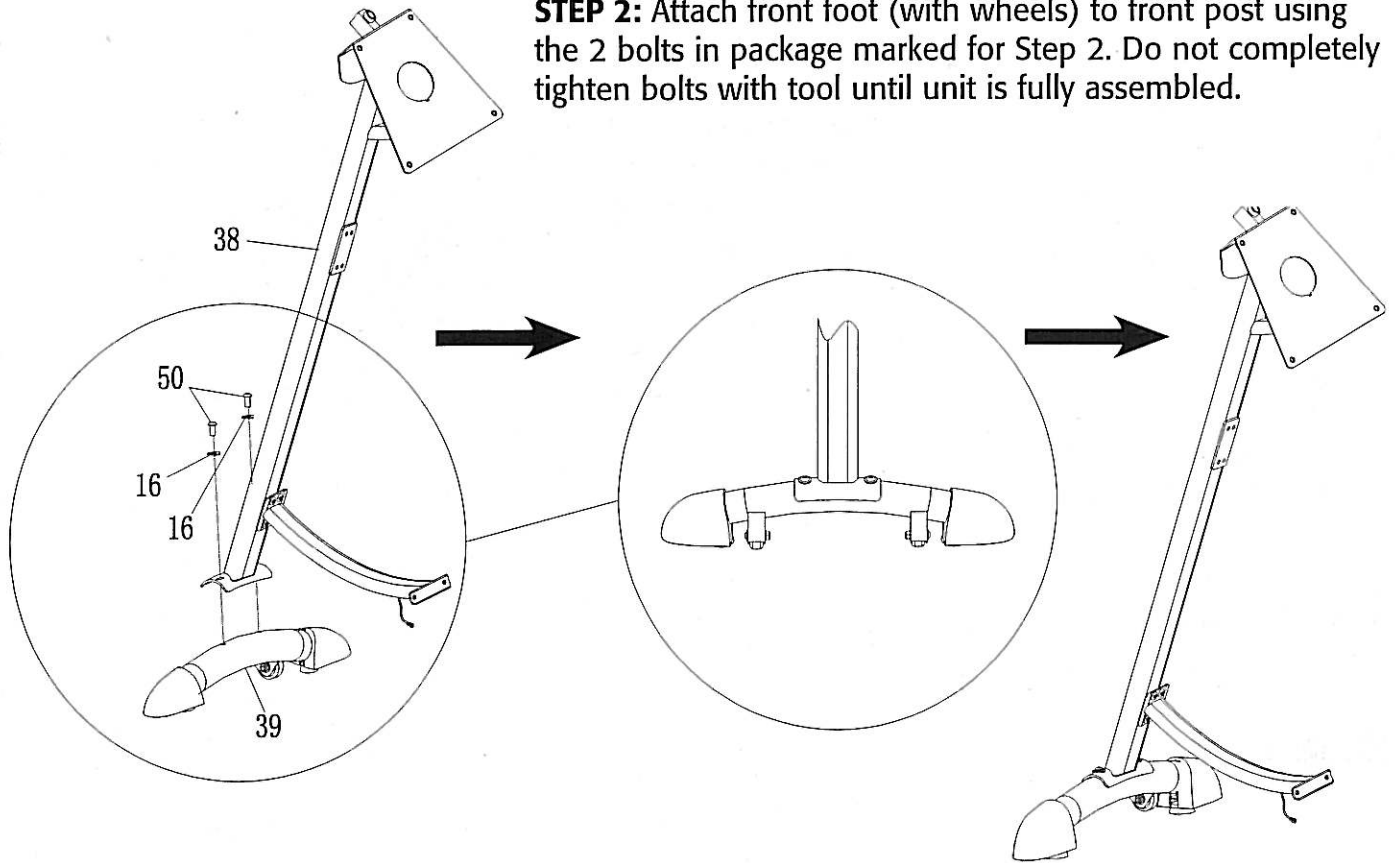

STEP 3: Attach front post to Ab Coaster® track in 2 locations as shown in diagram. Prior to fastening, (using 6 Allen head screws) make sure holes are properly aligned. Do not completely tighten bolts with tool until unit is fully assembled.

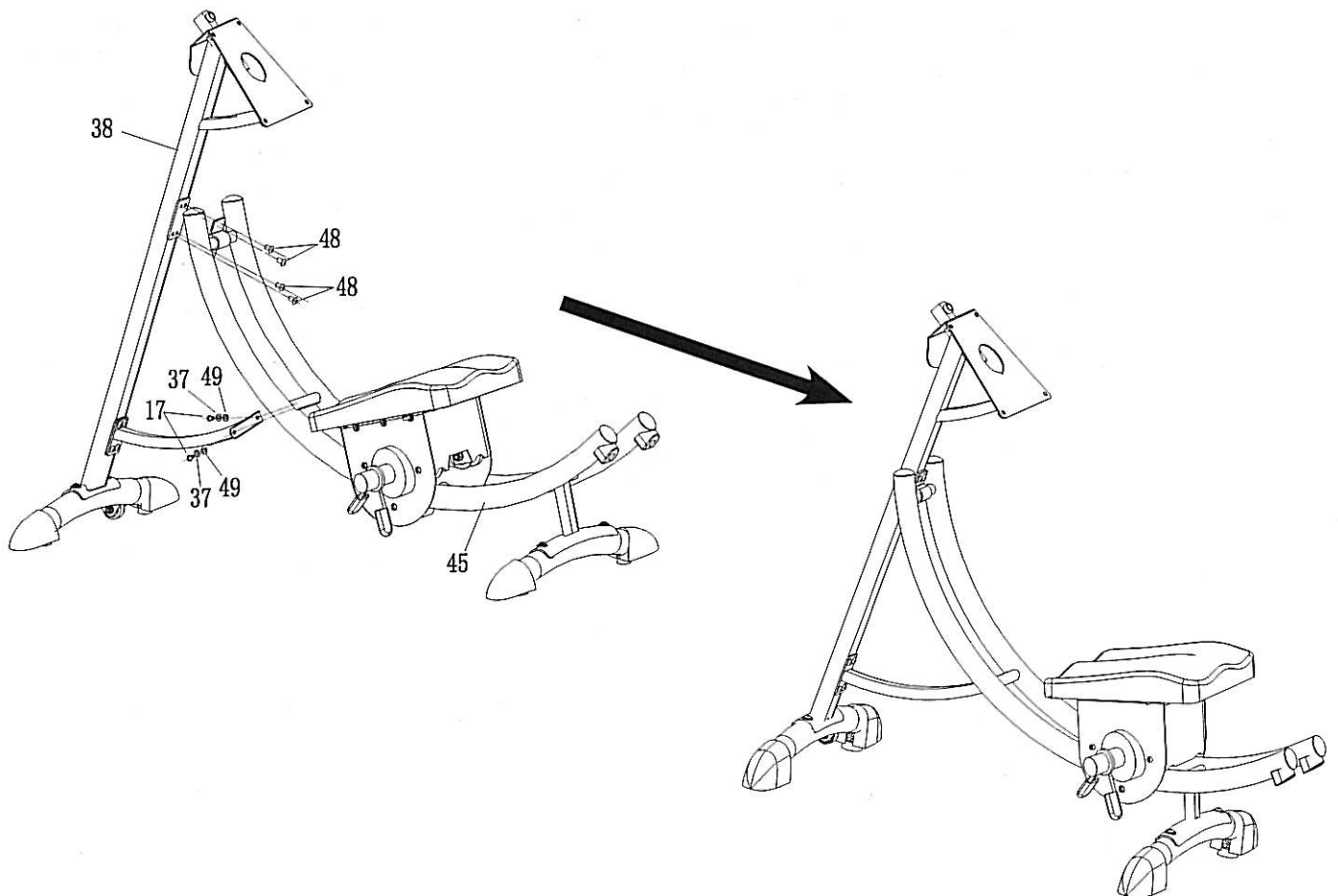

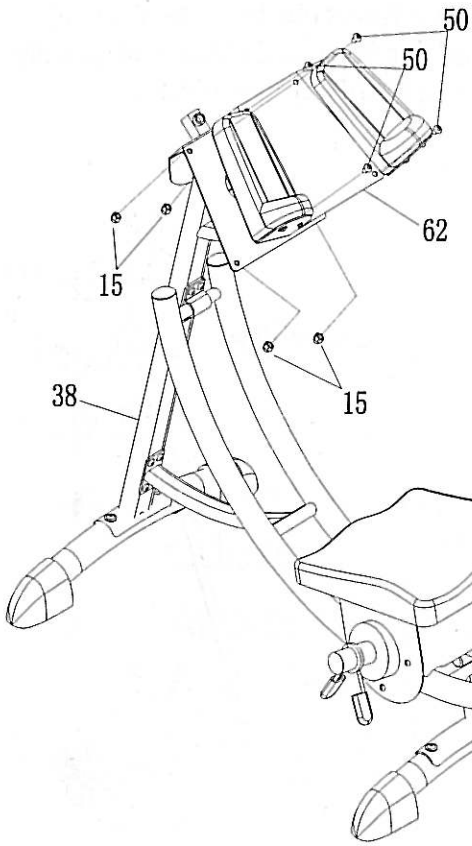

STEP 4: Attach armrest console to top of front post using the 4 Allen head screws.

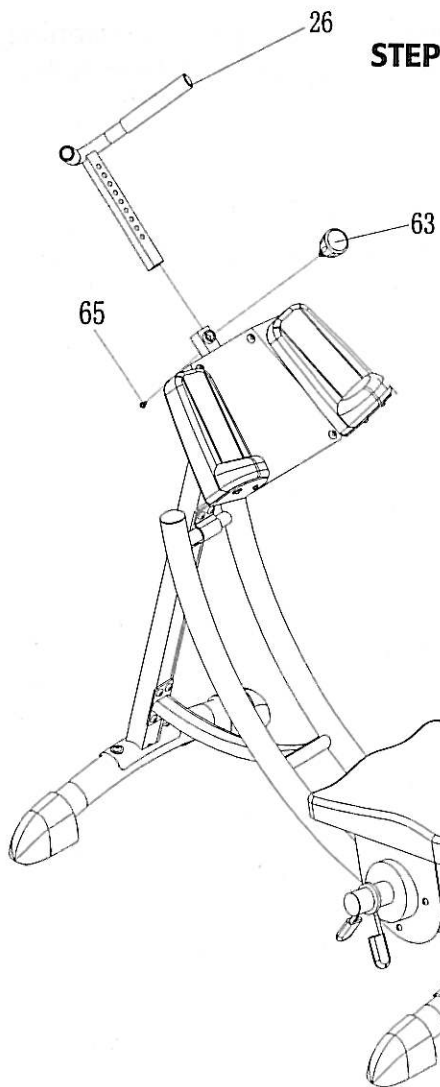
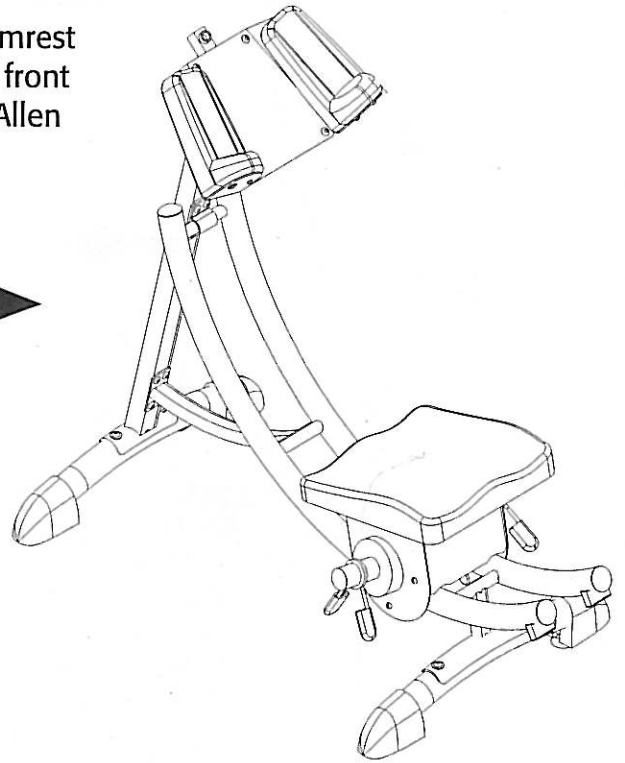

STEP 5: Attach hand grip to arm rest console.

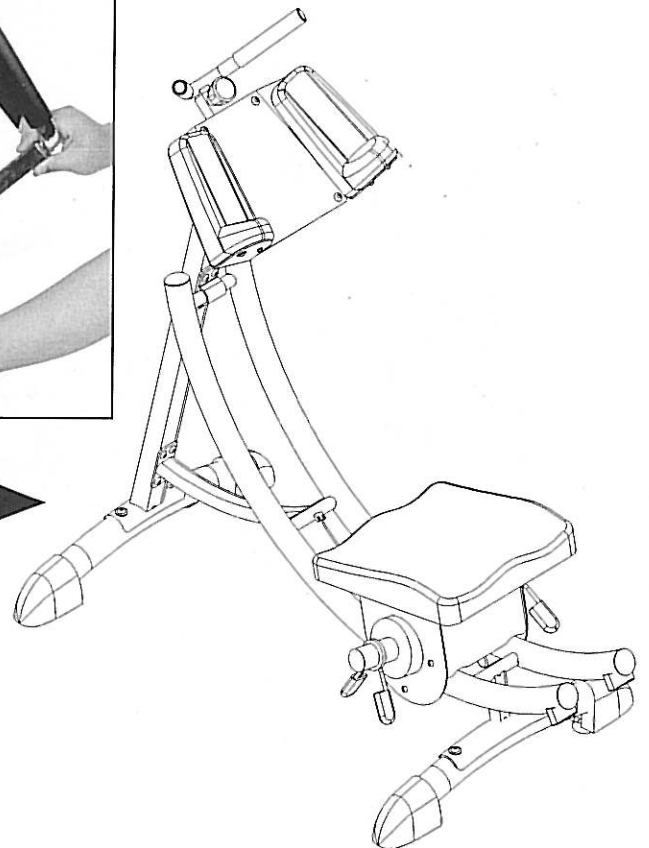

STEP 6: Tighten all bolts and screws using tools provided. Now you may safely cut the strap that secures the SEAT. (The strap with the Caution label that says "Do Not Cut"). Adjust levelers located under front and rear feet as needed.

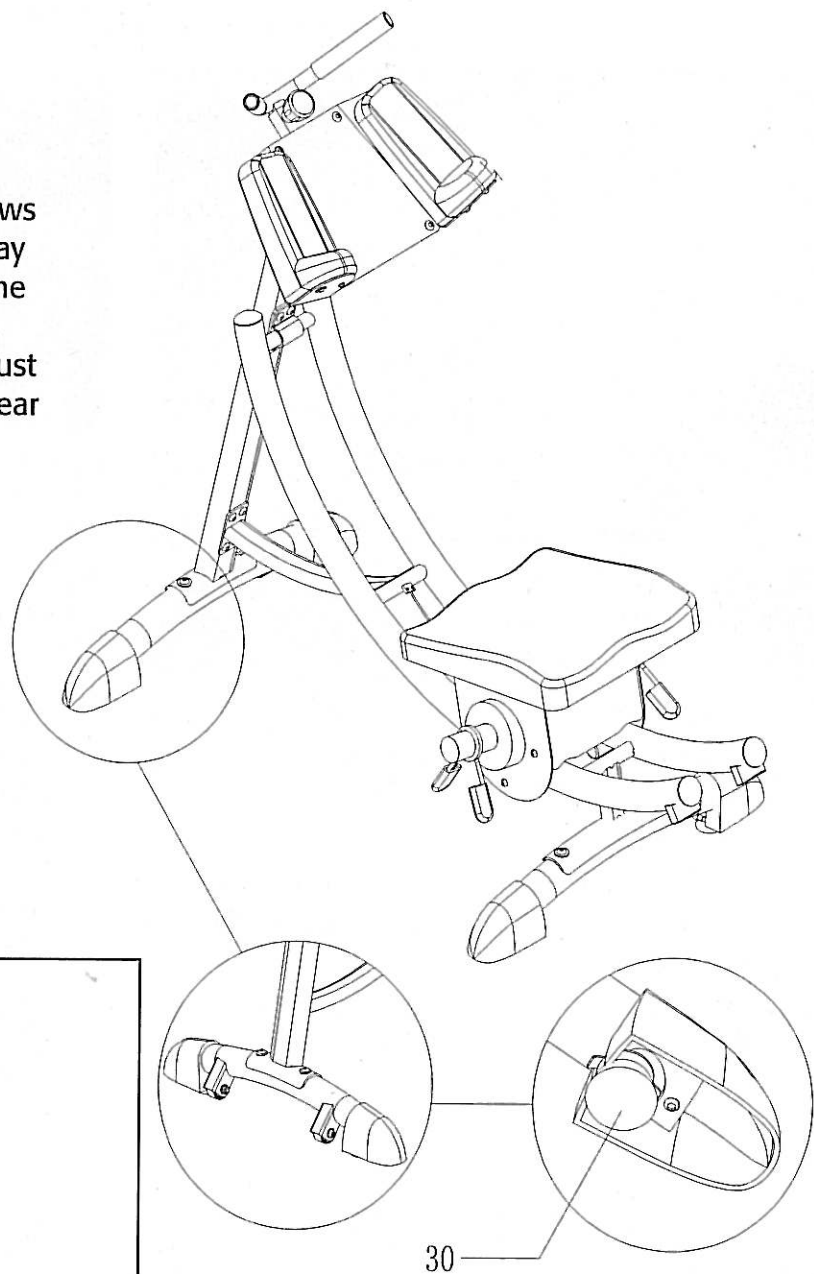

30

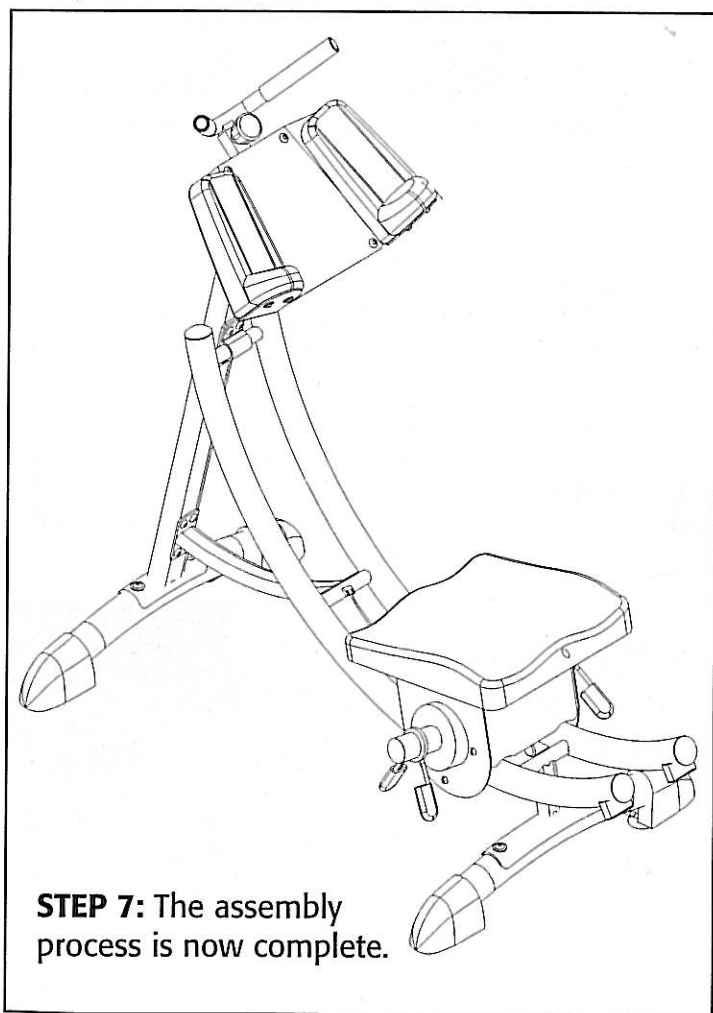

STEP 7: The assembly process is now complete.

GETTING ON AND OFF THE Ab Coaster®

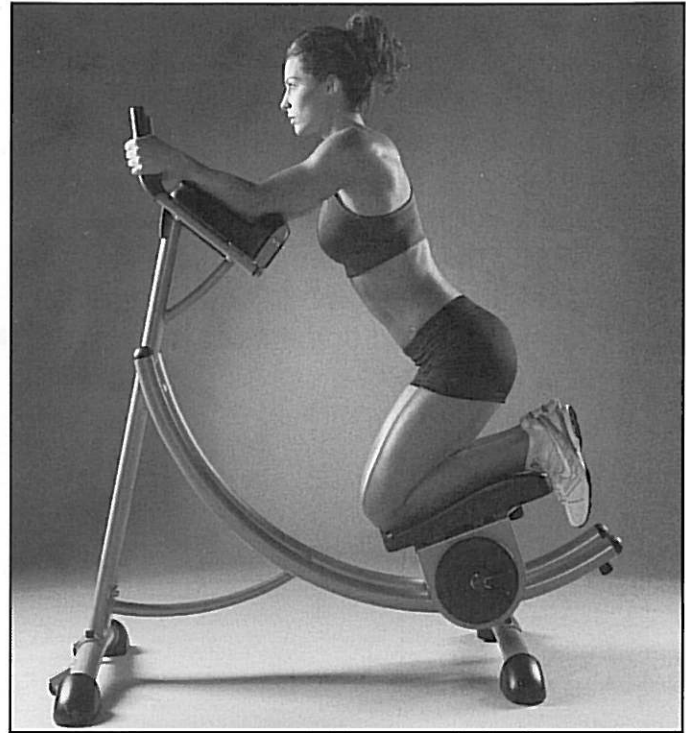
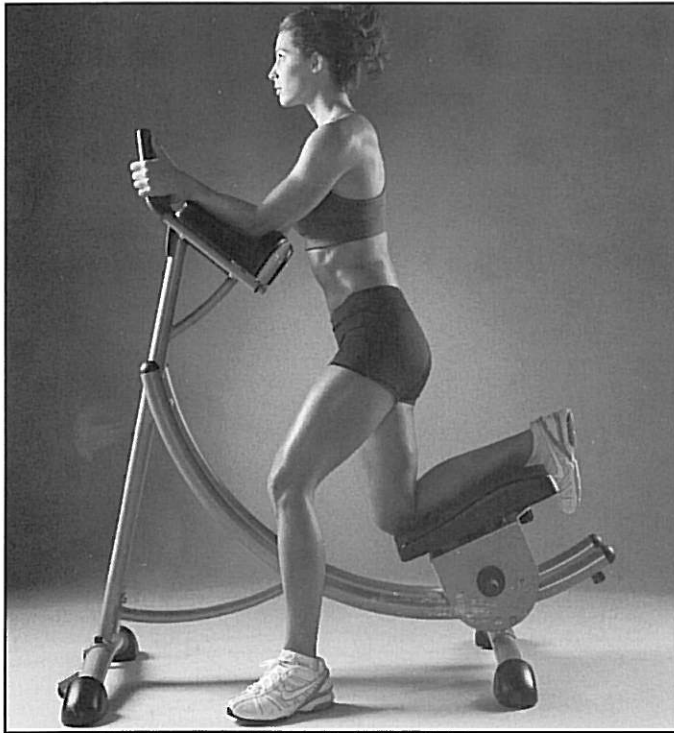

Step 1: Make sure the Ab Coaster® is placed on a flat, stable surface.

Step 2: Approach the Ab Coaster® from the side, not the back, of the unit.

Step 3: Adjust Hand Grip and place forearms and elbows on arm pads. Grasp handles to maintain your balance.

Step 4: While grasping handles, place knees on Seat so that your feet are hooked on the back edge of the seat. You are now ready to exercise.

WRONG

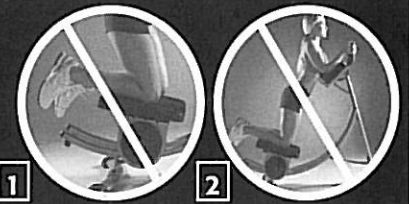

- 1 - Foot should be hooked on back edge of seat.
- 2 - Do not lean forward; sit back toward your heels.

AB COASTER® EXERCISES **How It Works:** The Ab Coaster® is designed to help you exercise your abdominal muscles via a leg lift motion. Unlike the popular sit-up or ab crunch exercise, which works your abdominals from the “top down”, the Ab Coaster® moves in the opposite direction, working your abs from the “bottom up.” The basic motion requires you to lift your knees and legs while contracting your abs.

The Ab Coaster® features a Seat moving along a curved track to aid you in performing the abdominal lifting motion. The starting position requires you to kneel on the Seat while resting your arms on the arm rests. The exercise requires you to lift the Seat along the track by using your abdominal muscles, not by using your arms or your upper body. The key to performing the exercise properly is to concentrate on contracting your ab muscles prior to and while you lift the Seat. Your upper body should be stable and should not be moving or swaying while you exercise.

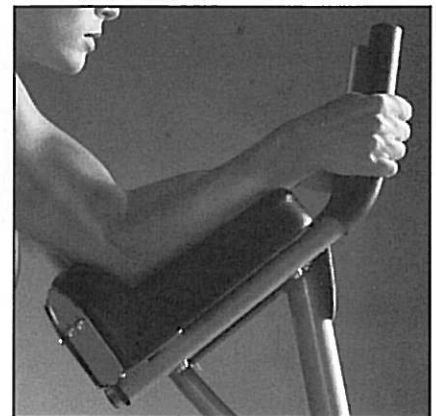
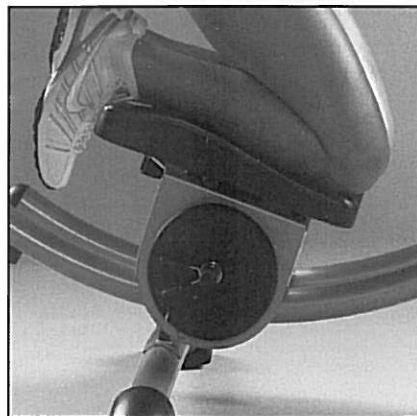

FORWARD LIFT

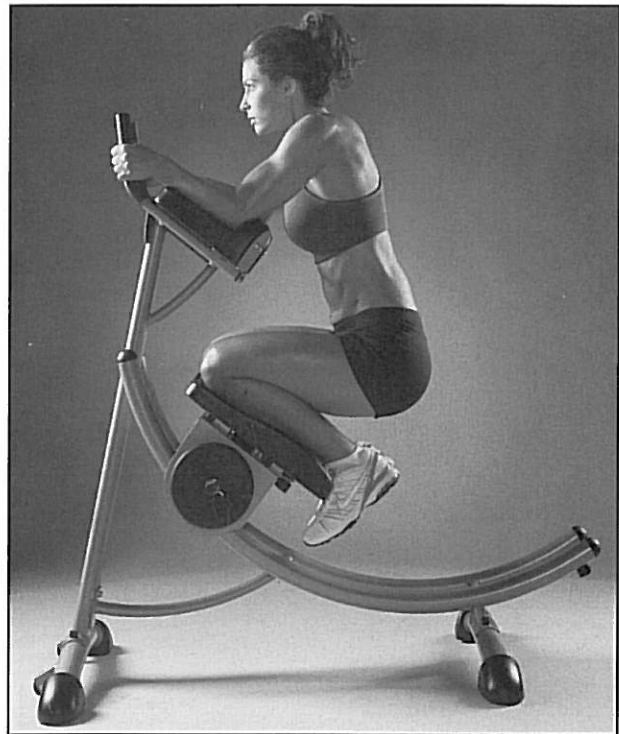
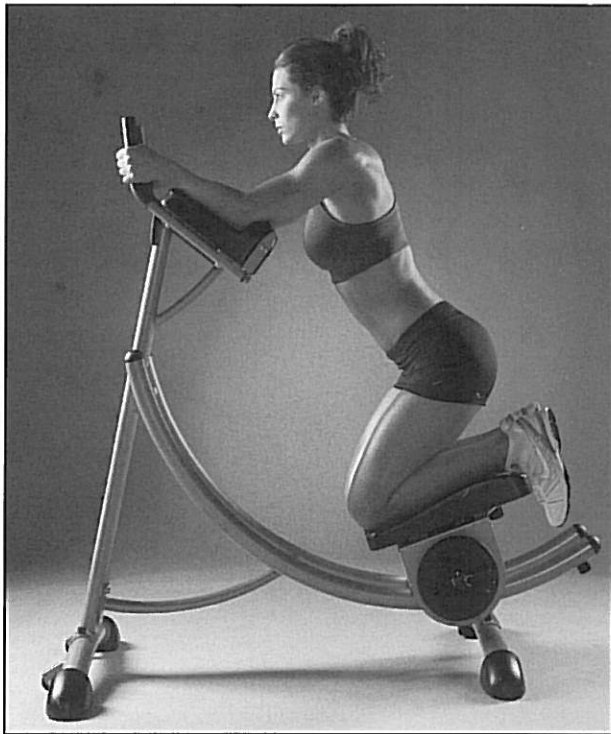

1. Adjust Hand Grip and place forearms and elbows on arm pads. Lightly grasp handles.
2. Kneel on Seat so that your feet are hooked on the back edge of the pad. DO NOT lean forward; sit back toward your heels.
3. While contracting your abs, lift your knees forward along the track. DO NOT move your upper body while performing exercise. Make sure you use your abs to lift the Seat carriage; DO NOT use your upper body or your arms to lift.
4. Return slowly to starting position, and repeat.
5. Use steady and slow speed while exercising. DO NOT use momentum to lift – concentrate on contracting and using your abs to lift. Do not use excessive force when lifting or returning Seat to starting position and avoid banging Seat against the track.

ADJUSTING THE SEAT

The Seat is free-moving so that you can turn your knees and work on your obliques. Turn knees to right to exercise right oblique; turn knees to left to exercise left oblique. Move side to side for free-style motion training.

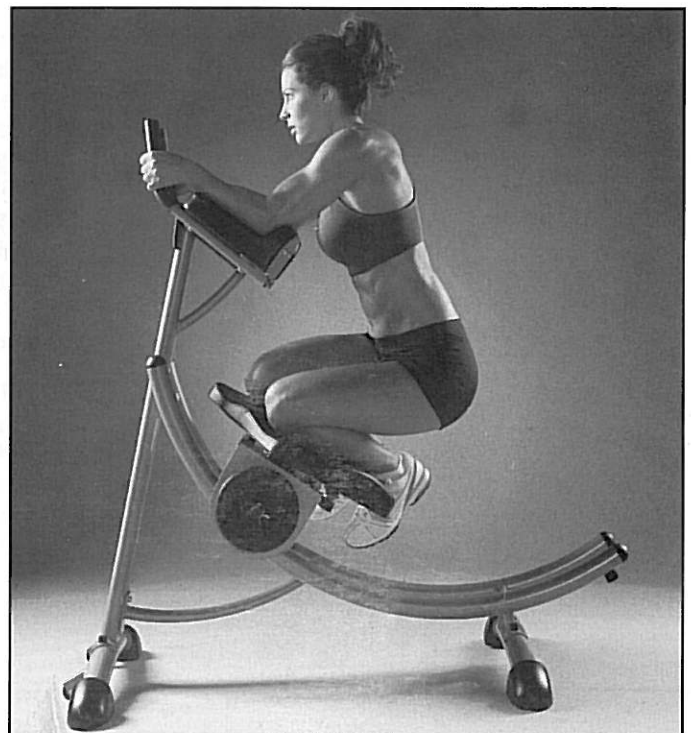
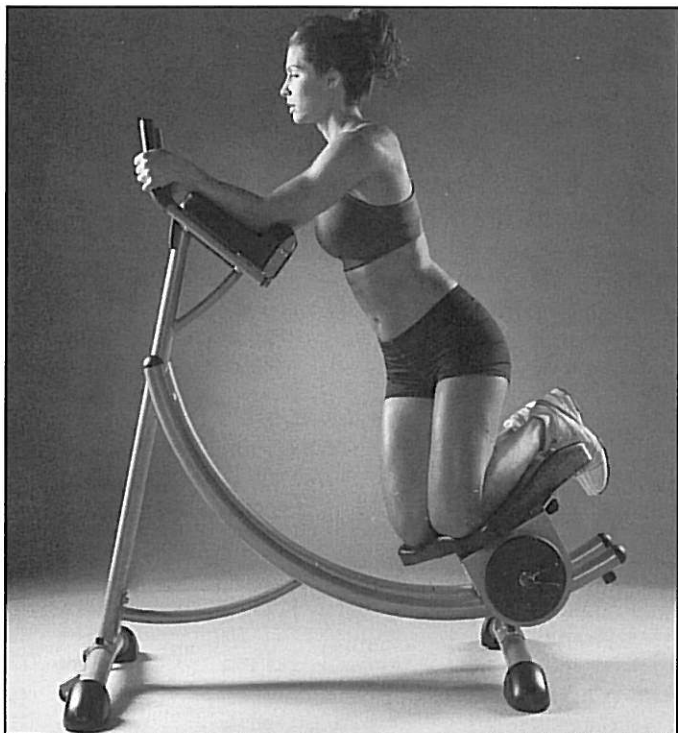

RESISTANCE TRAINING *(Weights Not Included)*

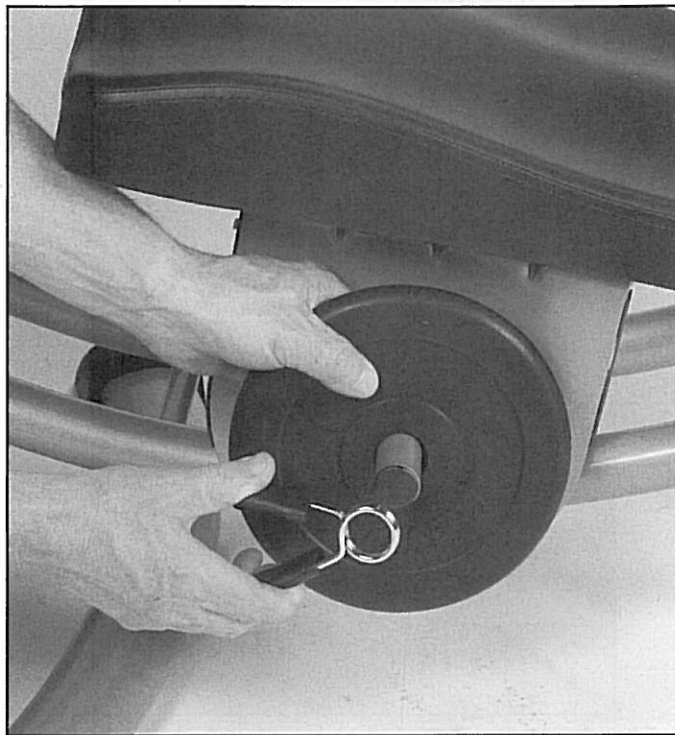
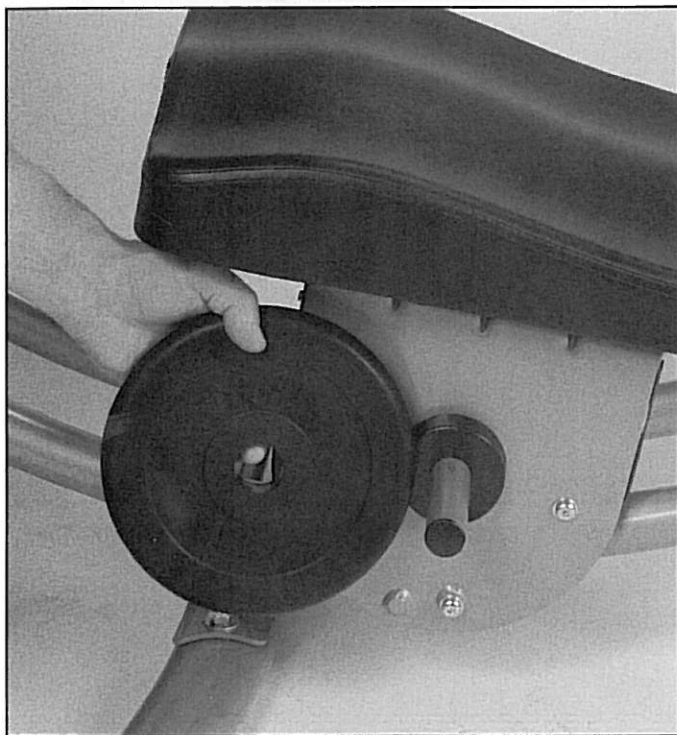

Using Added Weight for Resistance: There are 2 weight posts on the sides of the Ab Coaster® Seat for adding weights (not included) for extra resistance during exercise.

CAUTION: Do not add more than 30 lbs. of weight in total to the posts. Before adding any weight, ensure that you are able to perform the exercise with proper form without any additional weights.

Please visit www.AbCoasterClub.com and www.AbCoasterBlog.com to view video of proper usage of the machine.

MOVING, STORING AND MAINTAINING THE AB COASTER®

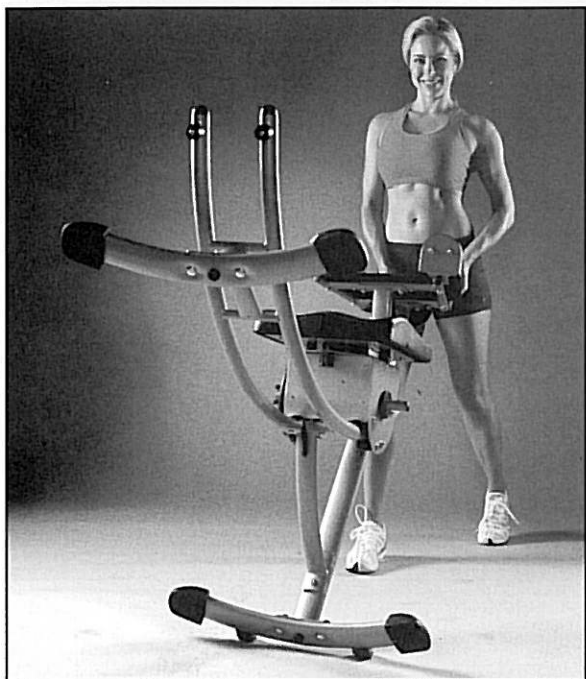

Moving and Storing:

There are 2 wheels attached to the front leg support of the Ab Coaster® in order to aid in the moving and storage of the unit. Stand in the front of the unit and grasp the handle bars. Push down on the handle bars tilting the rear up until the front wheels are engaged. For storage, keep the unit in a dry place. If placed in long-term storage, you should cover the unit with a cloth or other material to protect the unit from excessive dust or dirt accumulation.

Maintenance:

Keep curved track clean and free of debris. Wipe periodically with cloth to keep track smooth and clean.

PARTS LIST AND VIEW

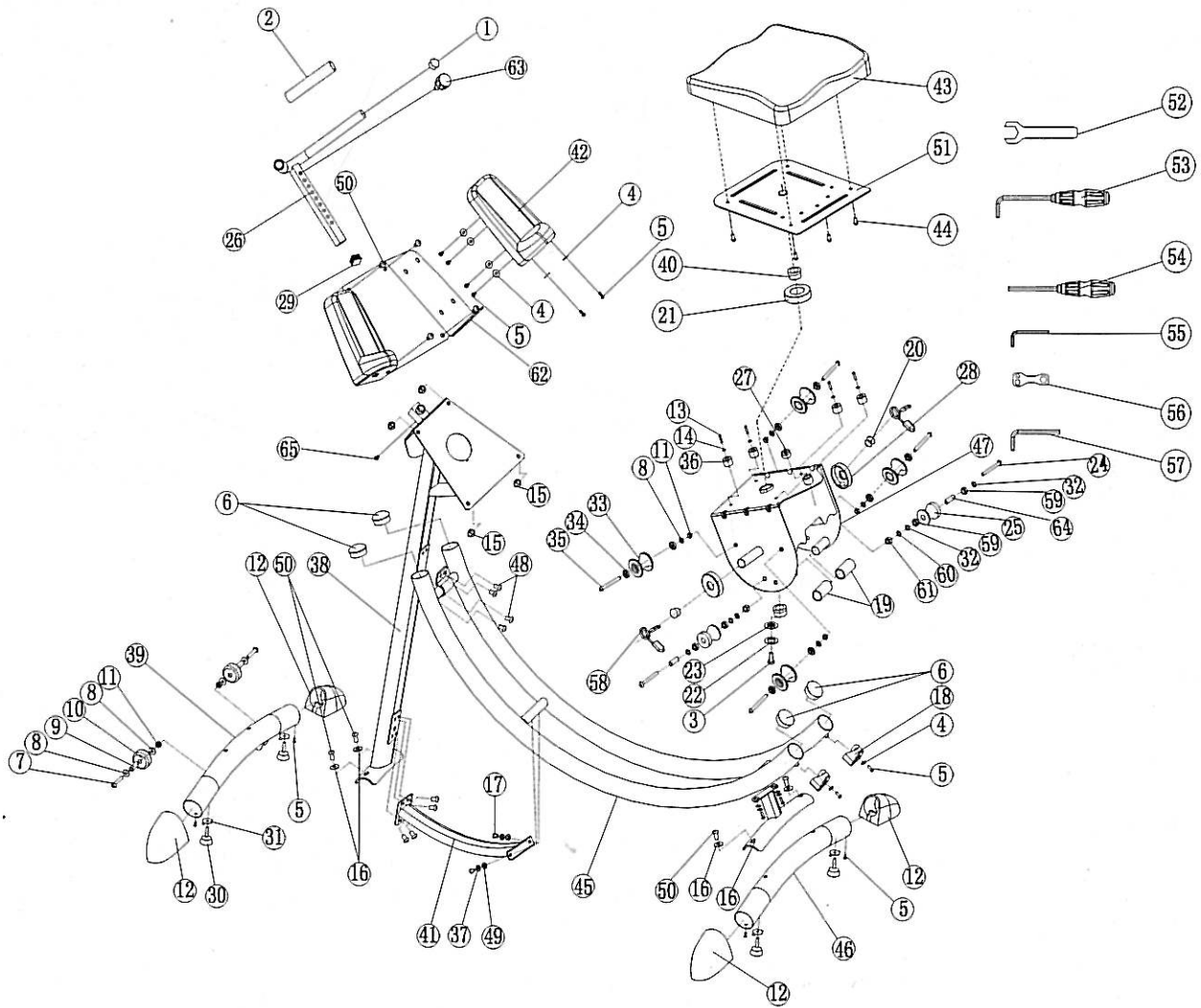

NO	Part Name	Specification	QTY(PCS)	NO	Part Name	Specification	QTY(PCS)	NO	Part Name	Specification	QTY(PCS)
01	circular piston match	match $\phi 25.4 \times 1.4$ tubing($\phi 31$)	2	26	arm plate console		1	51	seat plate		1
02	handlebar grip	$\phi 23 \times 3 \times 220$	2	27	muffler	$\phi 28 \times 13$	1	52	wrench tool	S17	1
03	M10*25 hex screw	M10*25	1	28	weight post collar	$\phi 70 \times 12$	2	53	green handle L-shaped allen tool	S6	1
04	$\phi 18$ flat washer	$\phi 18 \times d6 \times 1.2$	14	29	square end cap	match $\phi 25 \times 25 \times 1.5$ tubing	1	54	green handle allen tool	S6	1
05	M6*15 hex screw	M6*15	18	30	leveler	$\phi 50 \times \phi 67, M10$ 44mm thread	4	55	allen tool	A S5	1
06	ball piston match	match $\phi 50.8 \times 2.0$ tubing	4	31	leveler orientation	$6.5 \times 54.5 \times 3.0, M10$	4	56	wrench tool	B S10/S13/S17	1
07	M8*45 hex screw	M8*45_20mm thread)	2	32	$\phi 15$ subulate flat washer	$D15 \times d10 \times 3$	4	57	allen tool	S6	1
08	$\phi 16$ flat washer	$\phi 16 \times d8 \times 1.5$	8	33	roller wheel	$\phi 50 \times \phi 60$	4	58	weight plate clamp		2
09	front foot wheel bushing	$\phi 13 \times 1.5 \times 41.5$	2	34	bearing	608ZZ_ABECE-5	8	59	bearing	6800Z	4
10	front foot wheel	$\phi 47 \times 27$	2	35	M8*85 hex screw	M8*85(20mm thread)	4	60	$\phi 20$ flat washer	$D20 \times d10 \times 2$	2
11	M8 nut	M8	6	36	seat swivel bushing	$\phi 25 \times 20$	4	61	M10 nut	M10	2
12	foot grip match	$128 \times 95 \times B6$	4	37	$\phi 8$ spring washer	$\phi 8$	4	62	arm plate assembly		1
13	M5*15 phillips screw	M5*15	4	38	front support post		1	63	handle adjustment knob	M16*1.5P	1
14	$\phi 10$ flat washer	$\phi 10 \times d5 \times 1.0$	4	39	front foot		1	64	spacing wheel bushing	$OD14 \times T2.0 \times L41.5$	2
15	M10 nut cap	M10	4	40	$\phi 38$ nylon sleeve	$\phi 38 \times \phi 25 \times 19$	2	65	M6xL15 hex screw	M6*15L	1
16	R40 $\phi 25$ arc washer	$\phi 25 \times d10 \times 2.0$ R40	4	41	front support brace		1				
17	M8*20 hex screw	M8*20	4	42	arm cushion	$255 \times 115 \times 115$	2				
18	bumper	$49 \times 44 \times 34$	2	43	seat cushion	$406 \times 368 \times 80$	1				
19	seat swivel bushing	$\phi 23 \times 37$	2	44	M8*15 hex screw	M8*15	4				
20	circular piston match	match $\phi 25.4 \times 1.4$ tubing	2	45	ab coaster cs1000 track		1				
21	nylon bushing	$\phi 70 \times \phi 40 \times 20$	1	46	rear foot		1				
22	$\phi 10$ spring washer	$\phi 10$	1	47	U shape seat carriage		1				
23	lifted washer	$\phi 38 \times \phi 10.5 \times 2$	1	48	M10*15 hex screw	M10*15	8				
24	M10*75 hex screw	M10*75	2	49	R12.5 $\phi 16$ arc washer	$\phi 16 \times d8 \times 1.5, R12.5$	4				
25	spacing wheel	$\phi 44 \times L52$	2	50	M10*20 hex screw	M10*20	8				

Thank you for purchasing the AB COASTER®.
Our customer service staff is ready to help
and to answer any questions.

Our phone number is: 908-879-2713
The Ab Coaster Company, 173 Route 206, P.O. Box 9
Chester, NJ 07930

Website: www.abcoasterclub.com

Email: info@abcoasterclub.com

Please call us if you have any questions.
Customer service can be reached
Monday to Friday from 9:00 AM to 5:00 PM EST.
You can also send us an email, or visit our website
for additional customer service information.

Prior to calling or emailing,
please have the following information with you:

- Customer Name and Address
 - Telephone Number
 - Proof of Purchase
 - Product Model Number

© 2010 The Ab Coaster Company. All Rights Reserved.
U.S. Pat. Nos. 7,485,079; 7,611,445; 7,455,633; D584,367; and other U.S. and Foreign Patents Pending
U.S. Trademark Registration Numbers 3407362 and 2632152

AbC_CS1500-NoCounter_MAN_V1_100316

