

ReNegaDE

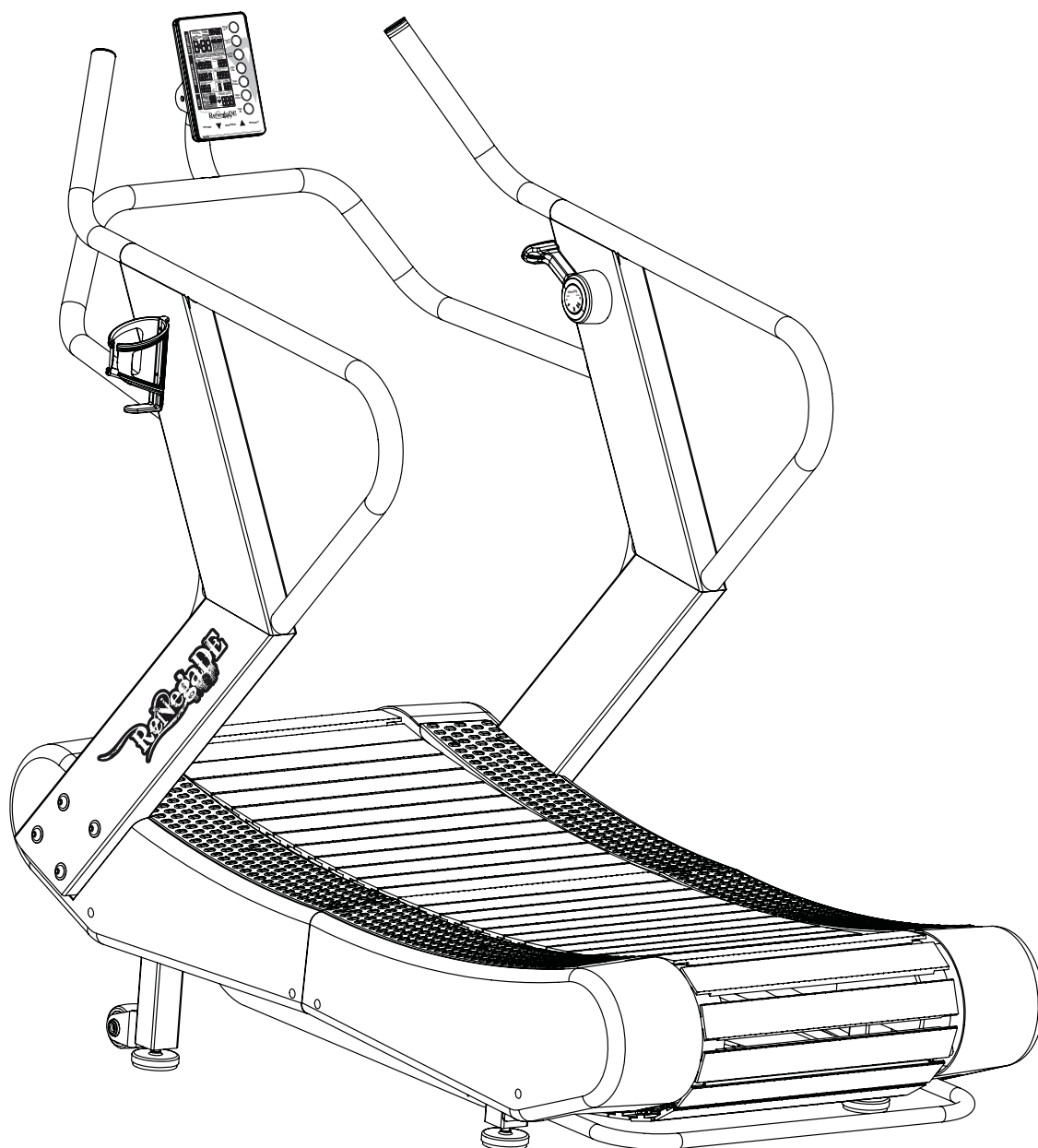

**PLEASE READ THIS INSTRUCTION MANUAL
BEFORE YOU BEGIN ASSEMBLY**

contents

safety information	03
customer support	04
assembly instructions	05
Runner features explained	09
computer instructions	10
- quick start	
- button functions	
- console display and feedback	
- using workout programs	
how to take care of your Runner	15
exercising with your Runner	16
I-1 console assembly	17
exploded diagrams and parts list	18
your warranty	22

Safety Information

PLEASE READ THIS INSTRUCTION MANUAL BEFORE YOU BEGIN ASSEMBLY. GREAT CARE HAS BEEN TAKEN TO DESIGN THESE INSTRUCTIONS AND FOLLOWING THEM WILL HELP YOU WITH QUICKER ASSEMBLY AND MINIMISE THE RISK OF INJURY

YOU ARE RESPONSIBLE FOR YOUR OWN SAFETY - THIS LIST IS NOT EXHAUSTIVE.

- Always assemble and operate the product on a level surface, ensure that the product is stable before use.
- Try to ensure that your back is straight whilst exercising, especially for long periods
- The safety level of this equipment can only be maintained if it is regularly examined for wear and tear
- Keep hands away from moving parts.
- Replace defective components immediately, and/or keep the equipment out of use until it is repaired.
- Use only the adjustment settings as described in the instructions. Always use the correct adjustment pin/fixing.
- Special attention should be taken to inspect the components, such as pulleys, bearings, straps, rollers are always more susceptible to wear before use.
- Never leave any adjustment devices projecting from the product.
- Always wear suitable clothing and footwear e.g. tracksuit / shorts / training shoes
- Remove all personal jewellery before exercising.
- Ensure you warm-up well before using the equipment as this will help to prevent muscle strain.
- After eating, allow 1-2 hours before exercising as this will help to prevent muscle strain.
- Never overload the equipment – the maximum user weight of this runner is 150kg.
- Don't rock the runner from side to side
- Never use the equipment in any other manner other than the ways explained in these instructions and/or any wall-chart supplied.
- This product has an intergrated resistance system without a constant power mode that is governed by magnetic resistance.
- Losing grip or suddenly releasing the handle could result in an uncontrolled return, ensure there is free space around the product.
- You may want to store this product away to save space - be aware of moving mechanical parts which could cause injury.
- To prevent shock, keep all electrical components, such as the console, motor, cord and switch away from water.
- Do not use any accessories that aren't specifically recommended by the manufacturer, these might cause injuries or cause the unit to fail.
- Work within your recommended exercise level, do **NOT** work to exhaustion.
- If you feel any pain or abnormal symptoms, **STOP YOUR WORKOUT IMMEDIATELY**. Consult your physician immediately.
- Parents and others in charge of children should be aware of their responsibility, because the natural play instinct and the fondness of experimenting of children can lead to situations and behaviour for which the training equipment is not intended
- If children are allowed to use the equipment, their mental and physical development and above all their temperament should be taken into account. They should be controlled and instructed in the correct use of the equipment.
- The equipment is under no circumstances suitable as a children's toy.
- This appliance is not intended for use by persons (including children) with reduced physical, sensory or mental capabilities, or lack of experience and knowledge, unless they have been given supervision or instruction concerning use of the appliance by a person responsible for their safety.
- **The free area shall be not less than 0.6 m greater than the training area in the directions from which the equipment is accessed.**

! Injuries to health may result from incorrect or excessive training.

! Heart Rate Monitoring System may be inaccurate, Over exercise may result in serious injury or death. If you feel faint stop exercising immediately !

! Be aware of the edges on the runner when in use or move it around.

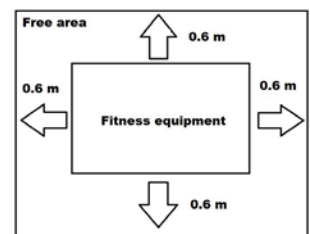

Safety Standards

This runner meets the requirements of the EN ISO 20957-1: 2013, EN-957-6, Class SC and also the EU's EMC and Low Voltage directives (where applicable).

This product is not suitable for therapeutic purposes.



! It is important that you keep these instructions for future reference.

Care & Maintenance

- Always place the equipment in a dry environment.
- Use a warm, damp cloth to keep the product clean.
- No wet cleaning of electrical components, unplug before any care and maintenance
- The safety level of the equipment can be maintained only if it is regularly examined for damage and wear. This includes any ropes, pulleys, nuts, bolts, moving parts, bushes, chains, wheels, bearings & connection points etc
- Ensure that you inspect the product regularly - at least once a week is recommended.
- Ensure that all fixings are tight before use.
- Always replace damaged / worn components with original parts from the manufacturer.

Protect the environment by not disposing of this product with household waste. Check your local authority for recycling advice and facilities (Europe only).



Customer Support

Should you require any assistance regarding this product please gather the following information, and then contact us using the details below:

1. Serial no. - this can be found on the sticker below, located as indicated. For future reference, please write down your serial number in the space provided below.
2. Original purchase date
3. Place of purchase
4. Information about the place and conditions of use
5. Precise description of the issue/defect

Your Serial No. is:

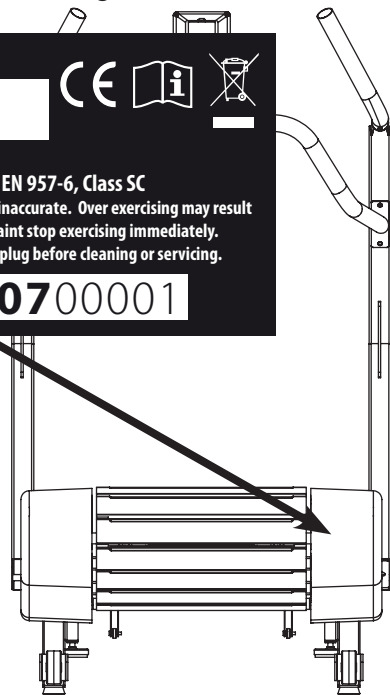
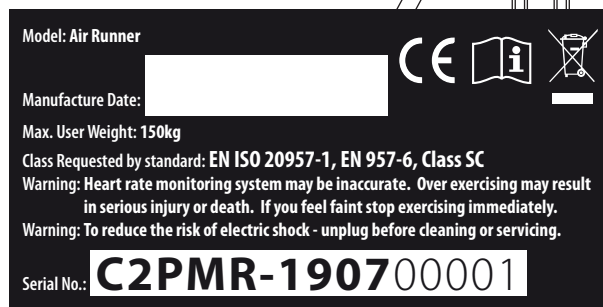

Contact Us

Assembly Instruction

Before you start

- 1. Prepare your work area -** it is important you assemble the product in a clean and uncluttered space.
- 2. Work with a friend -** we recommend you have someone assist you with the assembly as some of the components are quite heavy.
- 3. Open the carton -** checking any warnings on the carton and make sure you have it the right way up.
- 4. Unpack the carton**
 - Remove all of the parts and packaging from above the runner and lay them out on the floor carefully.
 - Flatten the sides of the carton and remove the rest of the packaging from around the runner.
 - Make sure you have the following parts –

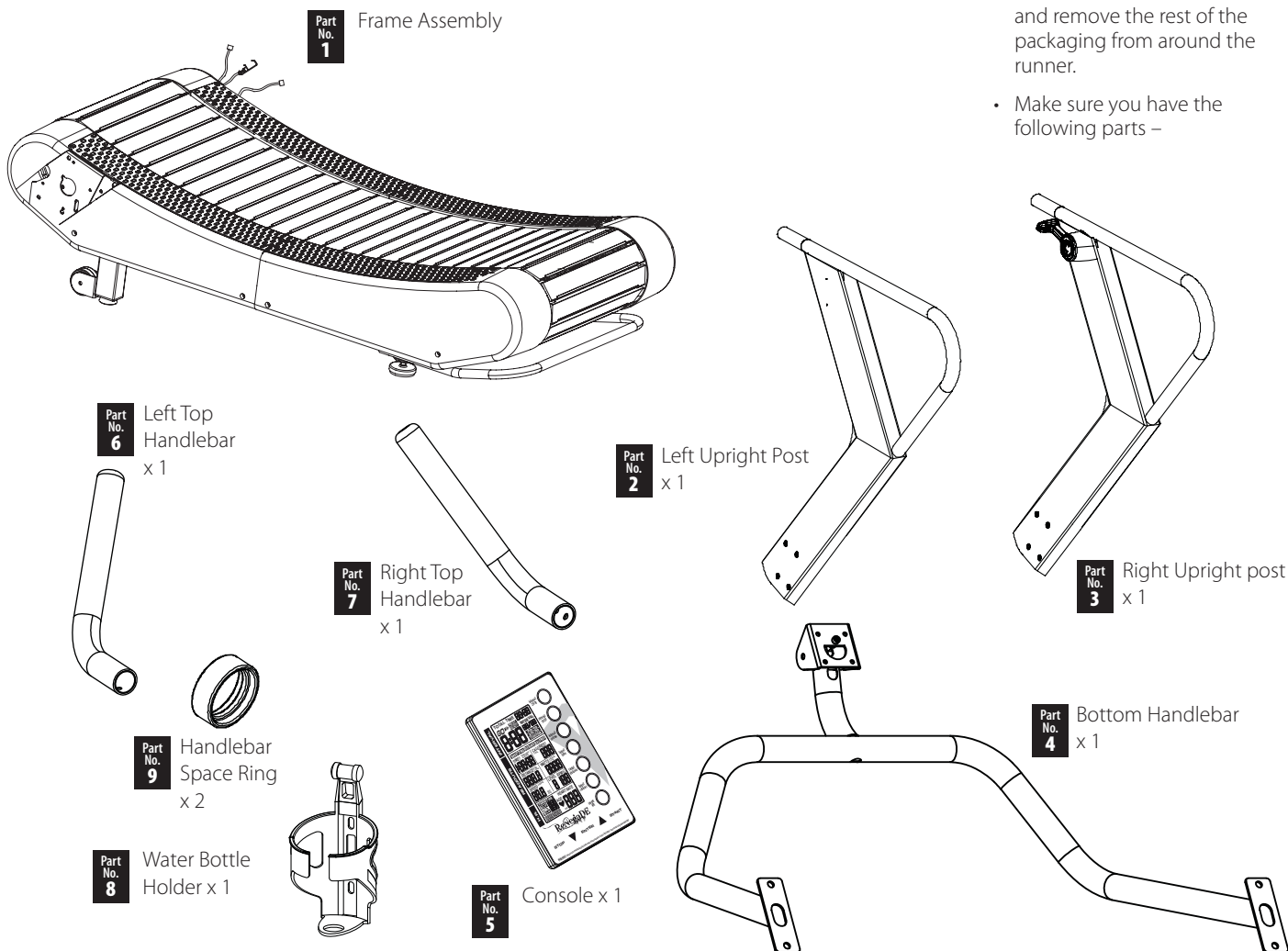

Fixings

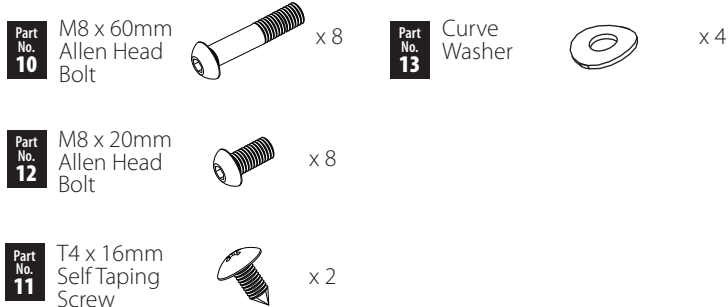

Tools and Consumables

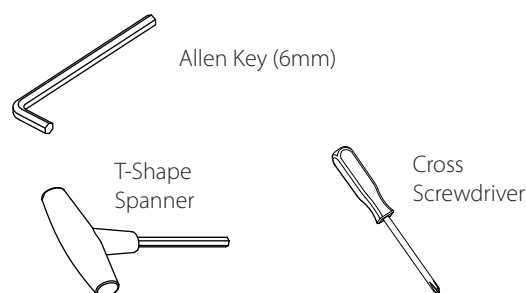

! This runner takes up a floor space of 170cm x 82cm and weighs 180kg

! If you suspect you may have some parts missing, please contact us before going back to your retailer. Refer to the Customer Support section on page 4 for contact details.

1. Attach the Upright Posts

1-1. Attach the Left Upright Post

- Ask some one to help you hold the **Left Upright Post Assembly (2)** in front of the **Left side Main Frame (1)** closely.
- Attach the **Left Upright Post (2)** to the front end of the **left side Main Frame (1)** with **four M8 x 60mm Allen Head Bolt (10)** with finger tight in position firstly and then secure with the 6mm Allen Key.

Make sure the bolts are fully tightened with the allen key.

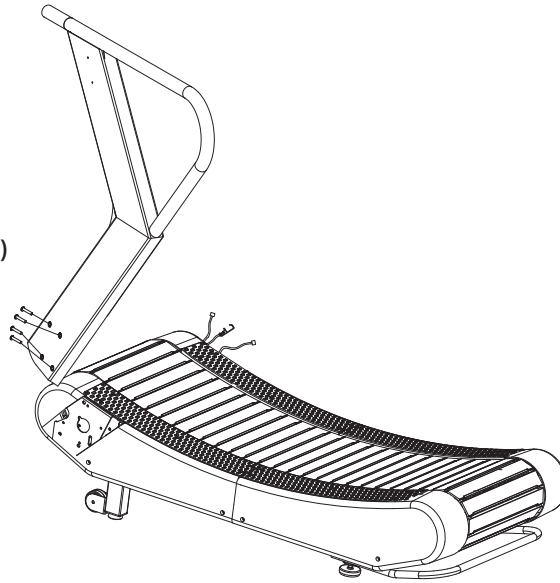

FIXINGS:

Part No. 10

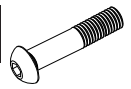

x 4

TOOLS:

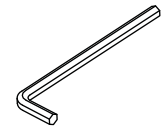

1-2. Attach the Right Upright Post

- Ask someone to help you hold the **Right Upright Post Assembly (3)** in front of the **right side Main Frame (1)** closely.
- Hook the inner tension cable together as shown (you may have to pull the outer tension cable firmly, to hook the upper cable into the bracket of the lower cable)
- Connect the **Middle Section Wires (2 pins & 3 pins) (15/17)** and **Sensor Wires (2 pins & 3 pins) (14/16)** together accordingly and tightly.
- Slide the rest of the connect wires & tension cables into the **Right Upright Post (3)** firstly and then attach the **Right Upright Post (3)** to the front end of the **right side Main Frame (1)** with **four M8 x 60mm Allen Head Bolt (10)** with finger tight in position firstly and then secure with the 6mm Allen Key.

Take Care to ensure the wires & cables are connected as tightly as possible, Slide the rest of the connect wires & cables into the right upright post before the Right Upright Post attachment.

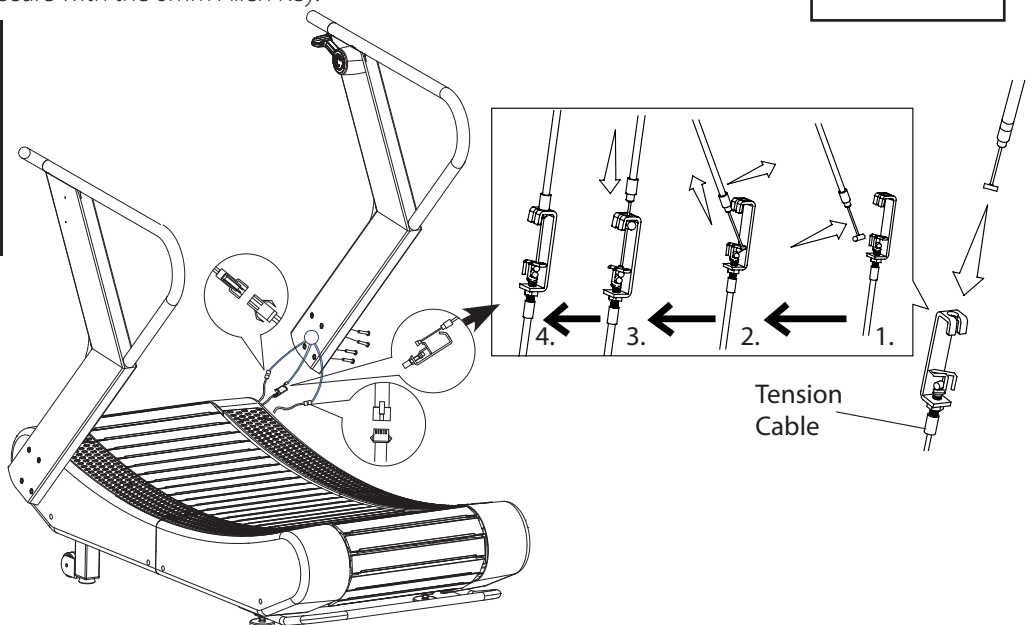

FIXINGS:

Part No. 10

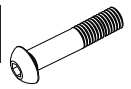

x 4

TOOLS:

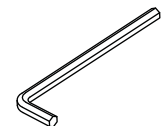

2. Attach the Bottom Handle

- Ask someone to help you hold the **Bottom Handle assembly (4)** in front of the **Upright Posts (2 / 3)** closely.
- Connect the **Middle Section Wires (2 pins & 3 pins) (15 / 17)** and **Top Section Wires (2 pins & 3 pins) (21 / 20)** together accordingly and then insert these two wires into the hole of **Right Upright Post (3)** carefully.
- Attach the **Bottom Handle assembly (4)** to the **Upright Posts (2/ 3)** carefully with four **M8x 20mm Allen Head Bolts (12)** with finger tight in position firstly and then secure with the 6mm Allen Key.

Take Care to ensure the wires are connected as tightly as possible, Slide the rest of the connect wires into the right upright post before the Bottom Handle attachment.

Make sure the bolts are fully tightened with the allen key.

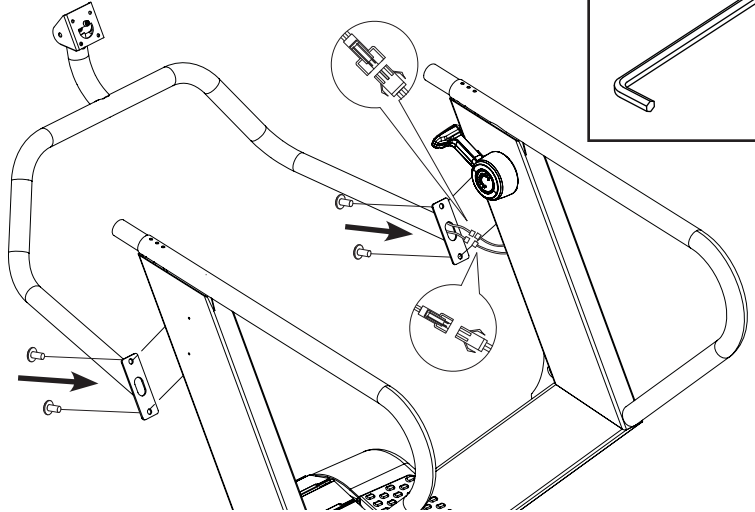

FIXINGS:

Part No. 12



x 4

TOOLS:

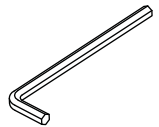

3. Attach the Top Handle

- Attach the **Reducer Ring (9)** to the **Top Handles (6 / 7)** firmly first.
- Attach the **Right Top Handle (7)** to the mounting tube of the **Right Upright Post (3)** carefully with two **M8 x 20mm Allen Head Bolt (12)** and **Curve Washer (13)** with finger tight in position firstly and then secure with the 6mm Allen Key.
- Attach the **Left Top Handle (6)** to the mounting tube of the **Left Upright Post (2)** carefully with two **M8 x 20mm Allen Head Bolt (12)** and **Curve Washer (13)** with finger tight in position firstly and then secure with the 6mm Allen Key.

Make sure the bolts are fully tightened with the allen key.

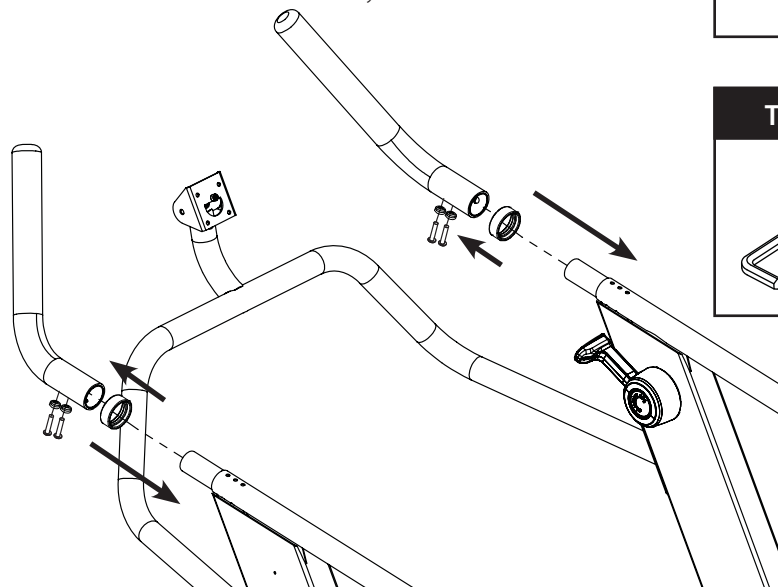

FIXINGS:

Part No. 12



x 4

Part No. 13



x 4

TOOLS:

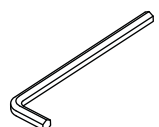

4. Attach the Console

- Remove the four **M5 x 10mm Fixing Screws (74)** which are located in the back of the **Console (5)**.
- Slide the **Console Cables (2pins & 3 pins)** through the open hole of the Console Bracket carefully as shown.
 - Attach the **Console (5)** to the Console Bracket assembled on the **Bottom Handle Assembly (4)** with four **M5 x 10mm Fixing Screws (74)** and secure with the Cross Screwdriver.
 - Connect the **Console Cables (2pins & 3 pins)** and **Top Section Wires (2 pins & 3 pins) (21 / 20)** together accordingly and tightly.
 - Take care to ensure the wires are connected as tightly as possible. Slide the rest of the connect wires into the console post carefully after the console attachment.**

Make sure the screws are fully tightened with the screw driver.

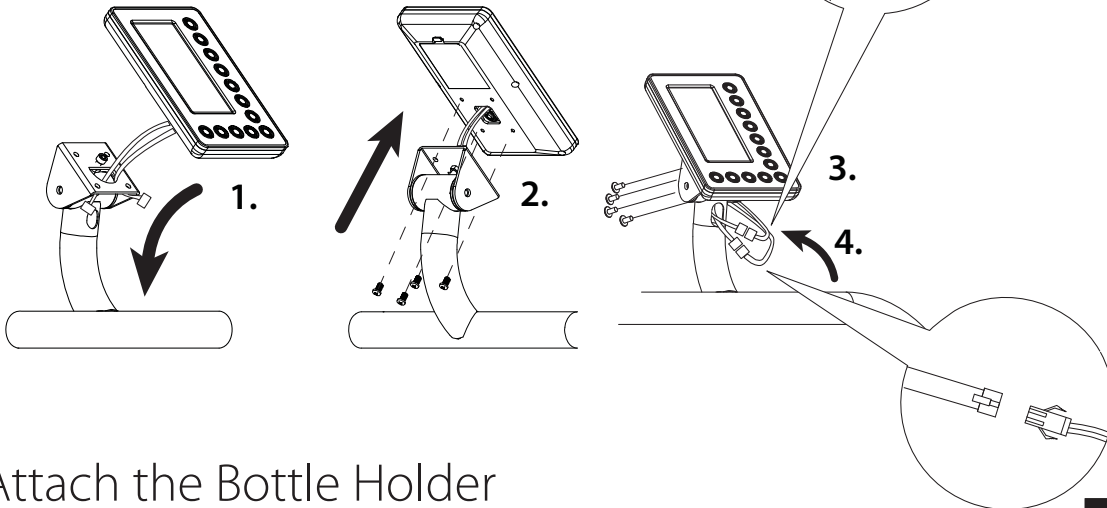

FIXINGS:

Part No. 74



x 4

TOOLS:

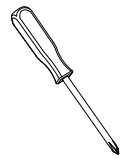

5. Attach the Bottle Holder

- Attach the **Bottle Holder (8)** to the top end of the **Left Upright Post (2)** with **two Self-Tapping Screws (11)** – provided and secured with the Screwdriver.

Make sure the screws are fully tightened with the screwdriver.

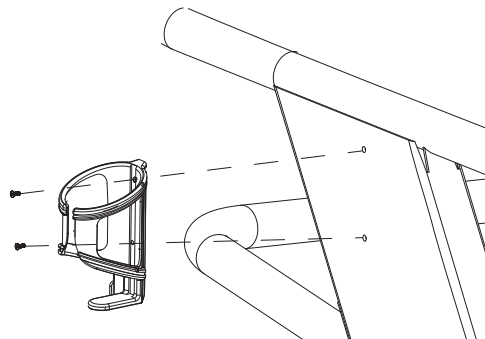

FIXINGS:

Part No. 11



x 2

TOOLS:

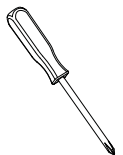

Final Checks

Your Runner is now assembled. Please make the following final checks before you use it for the first time.

- Make sure all screws, bolts and nuts are tightened securely.
- Make sure you have positioned it on a flat, level surface floor.

Runner Features Explained

Levelling your Runner

1. To help you level the Runner on uneven surface, 2 height adjusters are included on the rear stabilisers. Simply turn it to adjust the height of the Runner.

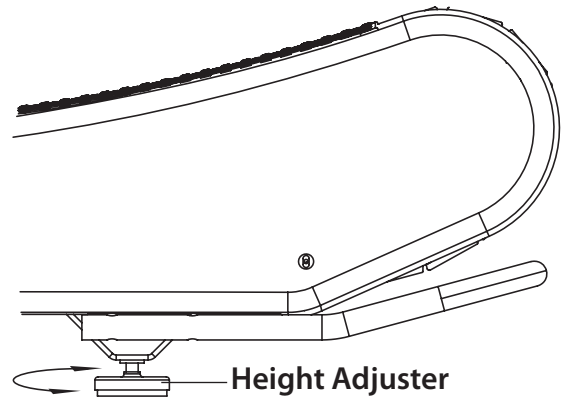

Transporting your Runner

1. Your Runner has 2 transport wheels on the front stabilizer.
2. Lift the Runner using the handle at the rear end of the Runner and then pull or push to move it around.



DO NOT USE THE CONSOLE SECTION TO TIP AND TRANSPORT THE RENEGADE RUNNER

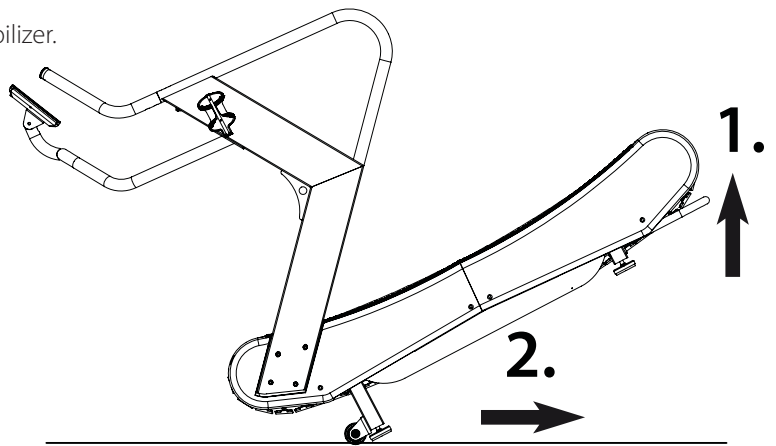

Adjusting the Resistance

1. This Runner features a speed independent (4 levels resistance adjustable) system.
2. The resistance is controlled by a manual magnet assembly by twisting the dial handle.
3. The resistance levels goes from 1 = easy to 4 = hard.

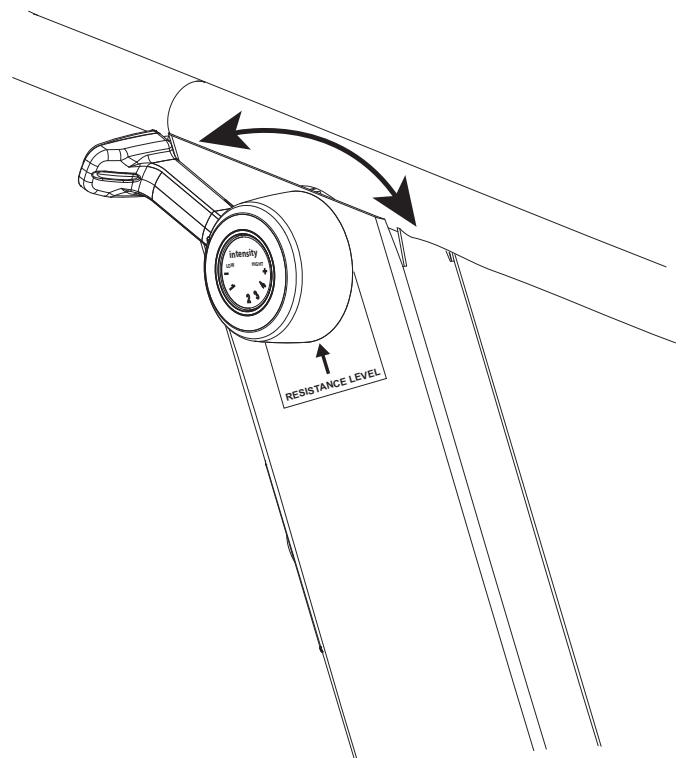

Computer Instructions

Quick Start

Use this mode if you just want a quick workout session and are not interested in setting up any personal data.

- Walk for a few seconds to power the console on.
- Press the “ **START** ” button.
- The values of **WATTS, SPEED, RPM, HEART RATE** (if heart rate signal is detected) will start displaying.
- The values of **TIME, DISTANCE, CALORIES, WATTS** will start counting upwards.

To finish this quick workout session and view your workout summary –

- Stop running.
- Press the “**STOP**” button.
- The values of **TIME, DISTANCE, CALORIES, WATTS, SPEED, RPM, HEART RATE** (if heart rate signal is detected) will be displayed.

“If you stop running without pressing the **STOP** button, after 30 seconds the program will automatically pause. You can resume the program by running again. After 3 minutes of inactivity the program will end.”

Button Functions

The diagram shows the ReNegade console interface with various readouts and control buttons. The interface is divided into three main sections: INTERVAL, READOUTS, and H.R. (Heart Rate). The INTERVAL section includes buttons for interval 20-10, interval 20-30, interval custom, target time, target distance, target calories, and target HR. The READOUTS section displays various metrics such as TOTAL TIME, GO, REST, READY, INTERVAL, 8:00, 88/88, 20/10, 20/30, CUSTOM, TARGET TIME, DISTANCE, CALORIES, REMAINING ELAPSED, CALORIES?, TIME?, WATTS, AVERAGE TOTAL, DISTANCE?, KM MILE, SPEED, AVE MAX, LEVEL, RPM, AVE MAX, and HEART RATE. The H.R. section displays TARGET HR, 65% OF, MAX HR, 80% OF, AGE, HEART RATE, NO HR SIGNAL, TARGET HR ACHIEVED, SPEED UP, SLOW DOWN, and BPM. The ReNegade logo is prominently displayed at the bottom of the console. Below the console, there are four control buttons: STOP, ENTER, and START, each with a corresponding arrow symbol (downward triangle, upward triangle, and a square).

“Interval” and “Target” Program buttons

- Immediately take you to the corresponding workout selected.

STOP

- To finish or pause a workout. Press and hold to reset the computer.



- To decrease values. Press and hold for rapid value change.

ENTER

- To confirm the settings.
- Exchange “**AVG**” & “**MAX**” display during the workout.



- To increase values. Press and hold for rapid value change.

START

- To begin a workout or restart a paused program

WARNING: Heart rate monitoring systems may be inaccurate. If you feel faint, stop exercising immediately

Console Display and Feedback

INTERVAL

- Indicates the current section is in **GO** period or **REST** period of the interval program.
- **8:88** > Shows the count down **GO** or **REST** segment time.

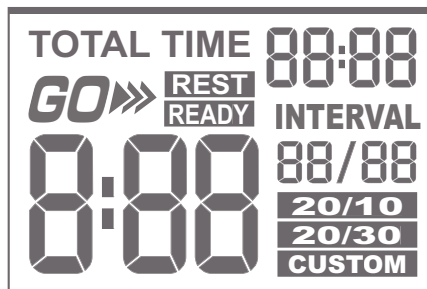

- **TOTAL TIME 88:88** > Shows the count up **GO** & **REST** total run time of the program.
- **88/88** > Shows the current interval and the total sections of intervals in the program.

- Indicates the **INTERVAL 20/10** or **INTERVAL 20/30** or **INTERVAL CUSTOM** program is selected and in used.

READOUTS

- Indicates the **TARGET TIME** or **TARGET DISTANCE** or **TARGET CALORIES** program is selected and in used.

- Indicates the time exercised this session, default counts up from zero to 1:59:00, but counts down if a target had been set.
- Indicates the distance travelled this session, default counts up from zero to 999.9 kilometers, but counts down if a target had been set.
- Indicates the current speed you are running at, in km /h.

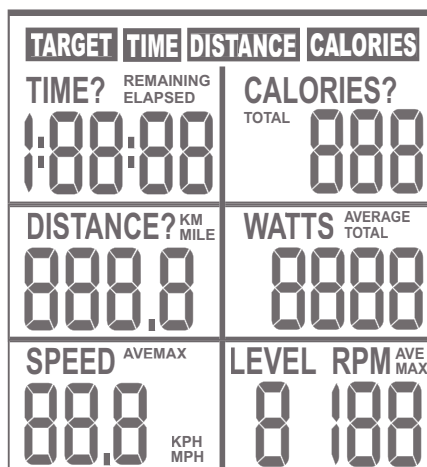

- Indicates the approximate calories burned this session (for comparison only, not to be used for medical purpose), default counts up from zero to 999 kcal, but counts down if a target had been set.

- Indicates the current energy (power) generated this session, (for comparison only, not to be used for medical purpose) default counts up from zero to 9999.

- Indicates the current Revolutions Per Minute you are running at.

- Indicates the resistance level loaded this session, 1 = easy and 4 = hard.

H.R.

- Indicates the current heart rate in beats per minute (bpm), which are detected by a wireless heart rate chest belt.

- Indicates the target to exercise at 65% of your maximum heart rate.
- Indicates the target to exercise at 80% of your maximum heart rate.
- Indicates there is no heart rate signal detected in this program.
- Indicates the current heart rate is in the target range.

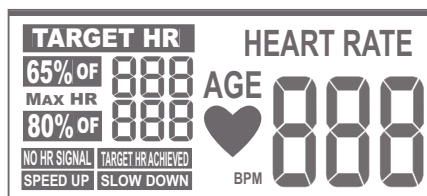

- Indicates the heart rate signal has been detected.

- Indicates an increased running speed is needed to bring the heart rate into the target range.
- Indicates an decreased running speed is needed to lower the heart rate into the target range.

Using Workout Programs

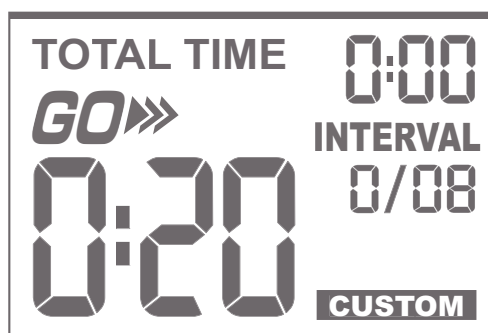
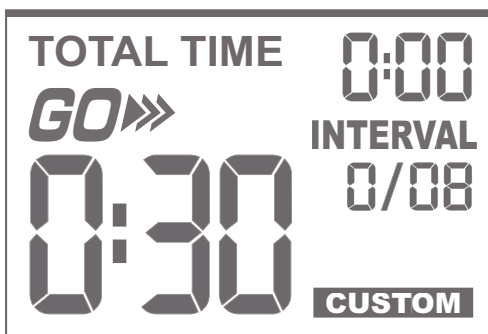
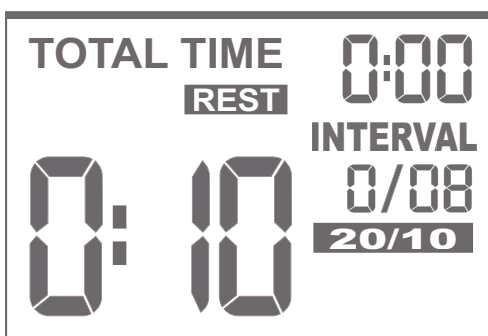
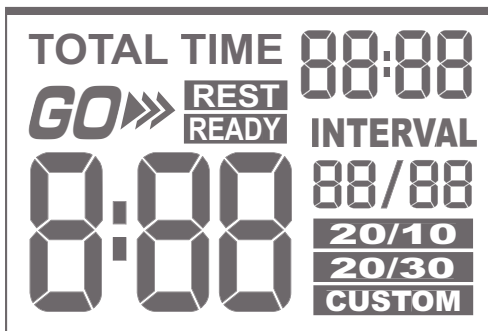

INTERVAL Programs

This console features 3 interval programs : **interval 20/10**, **interval 20/30** & **interval custom**.

The **interval 20/10** and **interval 20/30** programs offer users a series of eight high-intensity workout intervals with preset time segments.

These High Intensity Interval Training (H.I.I.T.) programs will automatically indicate the start of each **GO** & **REST** interval.

When you reach the last "**REST**" segment the console will sound a short alarm and end the workout by coming to a stop.

Interval 20 /10 Program

1. Make sure the console is switched on.
2. Press the "**interval 20/10**" to select the program mode you want.
3. The default interval number of "**0/08**" is displayed in the "**INTERVAL**" window.
4. The default time segment of "**REST 0: 10**" is displayed in the "**INTERVAL**" window.
5. Press "**ENTER**" to confirm your setting.
6. Press "**START**" to begin the workout and then start running.

The program will not start until you begin running.

NOTE: You can press the "**STOP**" button to end the program at any time. The workout summary will displayed on the screen.

NOTE: You can press the "**ENTER**" button to switch "**AVG**" & "**MAX**" of **SPEED / RPM** readouts during the workout.

Interval 20 /30 Program

1. Make sure the console is switched on.
2. Press the "**interval 20/30**" to select the program mode you want.
3. The default interval number of "**0 /08**" is displayed in the "**INTERVAL**" window.
4. The default time segment of "**REST 0: 30**" is displayed in the "**INTERVAL**" window.
5. Press "**ENTER**" to confirm your setting.
6. Press "**START**" to begin the workout and then start running.

The program will not start until you begin running.

NOTE: You can press the "**STOP**" button to end the program at any time. The workout summary will displayed on the screen.

NOTE: You can press the "**ENTER**" button to switch "**AVG**" & "**MAX**" of **SPEED / RPM** readouts during the workout.

Interval custom Program

1. Make sure the console is switched on.
2. Press the "**interval custom**" to select the program mode you want.
3. Use the "**▼ / ▲**" buttons to set your **GO** segment time (0:01 ~ 9:59 minutes)
4. Press "**ENTER**" to confirm your setting.
5. Use the "**▼ / ▲**" buttons to set your **REST** segment time (0:01 ~ 9:59 minutes)
6. Press "**ENTER**" to confirm your setting.

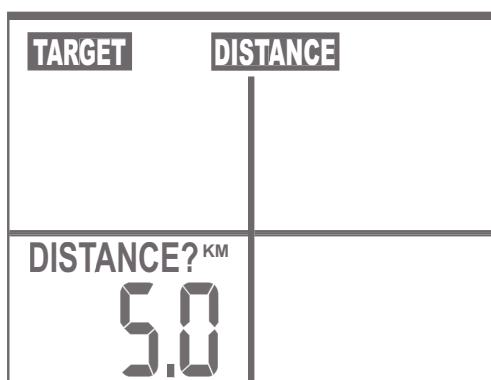
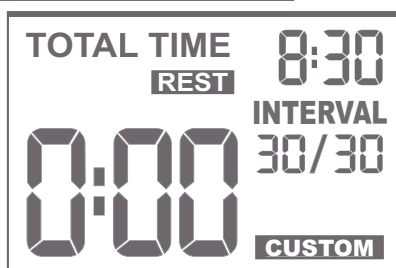
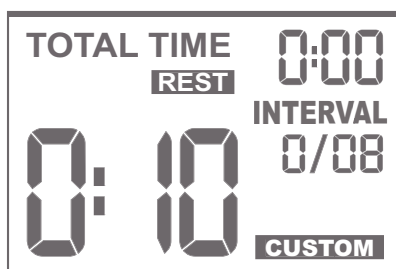

7. Use the "▼/▲" buttons to set your total interval numbers (1 ~ 99)

8. Press "ENTER" to confirm your setting.

9. Press "START" to begin the workout and then start running. The program will not start until you begin running.

NOTE: You can press the "STOP" button to end the program at any time. The workout summary will displayed on the screen.

NOTE: You can press the "ENTER" button twice to save the setting of this program after you complete the workout.

NOTE: You can press the "ENTER" button to switch "AVG" & "MAX" of SPEED / RPM readouts during the workout.

TARGET Programs

This console features 4 target programs : Target Time, Target Distance, Target Calories & Target Heart Rate. When you reach your target the console will sound a short alarm and end the workout by coming to a stop.

Target TIME

1. Make sure the console is switched on.
2. Press the "target time" to select the program mode you want.
3. Use the "▼/▲" buttons to set your workout time (1:00 ~ 1:59: 00 minutes)
4. Press "ENTER" to confirm your setting.
5. Press "START" to begin the workout and then start running. The program will not start until you begin running.

NOTE: You can press the "STOP" button to end the program at any time. The workout summary will displayed on the screen.

NOTE: You can press the "ENTER" button to switch "AVG" & "MAX" of SPEED / RPM readouts during the workout.

Target DISTANCE

1. Make sure the console is switched on.
2. Press the "target distance" to select the program mode you want.
3. Use the "▼/▲" buttons to set your target distance (0.1 ~ 999.9km)
4. Press "ENTER" to confirm your setting.
6. Press "START" to begin the workout and then start running. The program will not start until you begin running.

NOTE: You can press the "STOP" button to end the program at any time. The workout summary will displayed on the screen.

NOTE: You can press the "ENTER" button to switch "AVG" & "MAX" of SPEED / RPM readouts during the workout.



Target CALORIES

7. Make sure the console is switched on.
8. Press the "target calories" to select the program mode you want.
9. The default value of "50" is flashing in the "CALORIES" window.
10. Use the "▼/▲" buttons to set your target calories (10 ~ 990 kcal)
11. Press "ENTER" to confirm your setting.
12. Press "START" to begin the workout and then start running. The program will not start until you begin running.

NOTE: You can press the "STOP" button to end the program at any time. The workout summary will displayed on the screen.

NOTE: You can press the "ENTER" button to switch "AVG" & "MAX" of SPEED / RPM readouts during the workout.

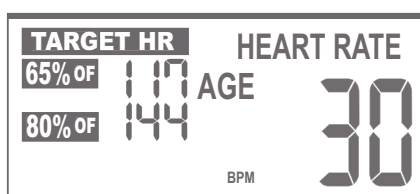

Target HR Program

You need to be wearing a compatible wireless heart rate chest belt to use this program.

Once you have entered your age the computer will calculate and display the corresponding values for 65% and 80% of your maximum heart rate, whilst also displaying your current heart rate. The computer will also prompt you to speed up or slow down to get within the 65% to 80% zone.

1. Make sure the console is switched on.
2. Press the "target HR" to select the program mode you want.
3. The default value of "30" is flashing in the "AGE" window.
4. Use the "▼/▲" buttons to input your age (10 ~ 99)
5. Press "ENTER" to confirm your setting.
6. The default value of the 65% of Target HR & 80% Target HR is displayed in HR window accordingly
7. Press "START" to begin the workout and then start running. The program will not start until you begin running.

NOTE: You can press the "STOP" button to end the program at any time. The workout summary will displayed on the screen.

NOTE: You can press the "ENTER" button to switch "AVG" & "MAX" of SPEED / RPM readouts during the workout.

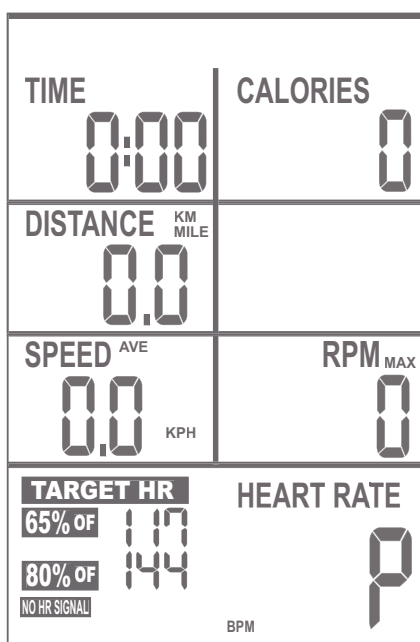

! Do not use the Target HR program if your heart rate is not registering properly on the display.

! "NO HR SIGNAL" will flash in the HR window if there is no wireless heart rate signal detected when the program starts.

! Please see the "Exercising with your Runner" section for more details about the benefits of target heart rate training.

How to Take Care of Your Runner

Storage

Keep the equipment in a dry place with as little temperature variation as possible. Try to protect from dust and always unplug when not in use (if applicable).

The safety level given by the design of this runner can only be maintained when this runner is regularly examined for damage and wear. Inoperable components should be replaced immediately or this runner should be put out of use until it is repaired

! Never remove the protective casing.

Your runner is designed for indoor exercising used only and should not be used or stored in damp areas.

Ensure you regularly check components for wear and make sure all the nuts & bolts are tightened before each exercise session

Maintenance Tips

- Always use a soft, cotton cloth and dilute non-abrasive cleaner or a mild detergent for cleaning the exterior of this runner.
- Never use ammonia, acid-based, or petroleum-based solvents on any portion of the runner as it may damage the finish.

Preventative maintenance Schedule

Daily –

- Before each use, make certain that the area around the runner is free of obstacles that may interfere with the arm swing.
- Before each use, check that slat running mat are securely tightened and inspect each slat for wear.
- After each use, wipe down the surface of the runner to remove sweat and moisture.
- Wipe the face of the display console with a slightly damp, soft, cotton cloth. Avoid getting extra moisture on the display console. Keeping the display console free of fingerprints and sweat will extend the life of the console.

Weekly –

- Thoroughly clean the plastic housing of the runner.
- Clean the top of the handlebar, side post, slats and the display console.
- Check that slats are securely tightened and inspect each slat.
- Inspect all assembly bolts & nuts for wear and ensure that they are sufficiently tight.

Monthly –

- Make sure all of the open ends of metal parts are wiped with thin grease to protect from rust.
- Check and Replace the Console AA Battery if needed.
- Clean for dust on running slat Assembly by spray gun if available.

! We do not recommend you attempt to service the internal parts of the running slat assembly. If they are found to be worn internally, we recommend replacing the running slat.

! Use of lubricants or cleaning solutions other than those so specified will result in diminished performance and a shorter life span for that part.

Exercising with Your Runner

Troubleshooting



If you have a problem with your equipment, before you do anything else please check that all the cables have been connected correctly. Loose cables are very common and many problems can be solved by making sure the cables are properly connected

If you are having problems with your heart rate reading please note that some fibres used in clothes eg) polyester, create static electricity that may prevent a reliable heart rate reading. Mobile phones, TV's, microwaves and other electrical appliances that generate an electromagnetic field may also interfere with heart rate measurement.

If you are still having problems with your equipment, please get in touch with your local distributor using the details found in the Customer Support section on page 4.



Always consult your doctor before undertaking a new exercise regime

If you experience nausea, dizziness or other abnormal symptoms during exercise, stop at once and consult your doctor

Starting your workout

Begin each workout with a Warm Up session – a few minutes of stretching to help prevent strains, pulls and cramps

- Get onto the runner, using the handrails for support, and place your feet on the side rails (either side of the running mat)
- Activate the runner console (using the details found in the Operation Instructions)
- Step onto the mat and walk at the lowest speed
- Continue the rest of your workout

Finishing your workout

- Adjust your pace to the lowest speed.
- Using the handrails for support place your feet on the side rails (either side of the running mat)
- Stop the runner.
- Get off the runner safely.
- If necessary, wipe the treadmill down with a damp cloth
- End each workout with a Warm Down session – a few minutes of stretching to help prevent strains, pulls and cramps.

Correct running form

- Run in the centre of the running mat
- Keep your head erect and look straight ahead
- Shoulders should be square and level, don't round your shoulders or swing them forwards or backwards
- Keep your torso erect with the chest up so there's plenty of room for the diaphragm to move for proper breathing actions
- Do not lean forwards, backwards or slouch, as all of these posture deviations can place a lot of stress on the lower back, interfering with proper running mechanics and possibly causing lower back injury
- Feet should be pointed straight ahead and land directly under the hips

How long should I exercise for?

That really depends on your current level of fitness. If you're just starting out on a new exercise program, you should start gradually and build up – do not try to do too much too quickly. 30 minutes, 3 times a week should be enough.

Don't push yourself too hard - you should never feel exhausted during or following exercise.

Heart Rate Training

To get the most out of your new piece of fitness equipment and see the best results from your training you should exercise at the right level of effort, and that means listening to your heart! Working out to a target heart rate means you can direct your workout to achieve different goals:

Good health - For those wishing to improve quality of life and general well being. Your sessions will need to be done at an intensity of between 50-60% of your estimated maximum heart rate, should last about 30 minutes and can be done on most days of the week.

Weight loss – To see a significant reduction in body fat, your sessions must be a little more intense - between 60 and 70% of your estimated maximum heart rate. These sessions can also be performed on most days of the week for up to 30 minutes.

Improving Fitness levels – These sessions should be performed at 70-80% of your estimated maximum heart rate and can also involve bouts of interval training that would have your heart rate peaking for short times near your maximum heart rate level. These are intense sessions and will require at least a 48 hour rest between sessions.

Calculating your target heart rate

First, you need to find your estimated maximum heart rate using the formula '220 minus your age in years'. So, if you are 35 years old your estimated maximum heart rate is:

$$220 - 35 = 185 \text{ beats per minute (bpm)}$$

Next, to calculate your target heart rate, simply multiply your estimated maximum heart rate (185bpm) by the applicable percentage. So, if your goal is better health:

$$185 \times 60\% = 111 \text{ bpm}$$



NOTE: The important issue to remember with all estimated calculations is that they are just estimates – if you don't feel comfortable exercising at your target then reduce it to a level you are comfortable with.

Note: Heart rate training requires you to monitor your heart rate throughout the workout. For this we recommend using a chest strap (if your machine has a wireless receiver) or a heart rate monitor. For more information please visit yorkfitness.com or get in touch using the Contact Us details on page 5.

I - 1 Console Assembly

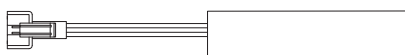
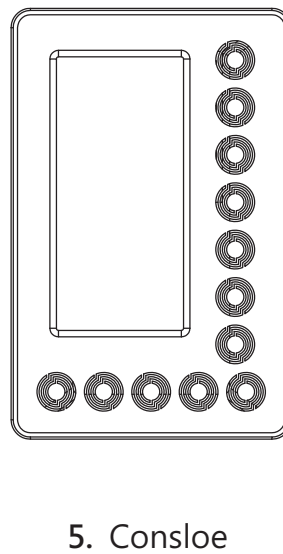
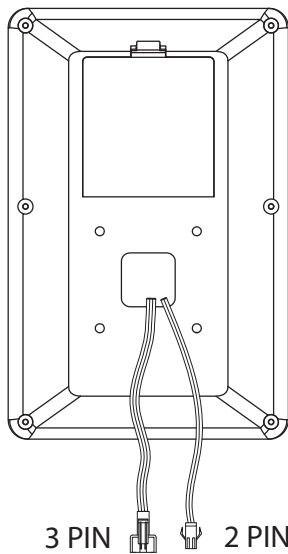

Product Profile

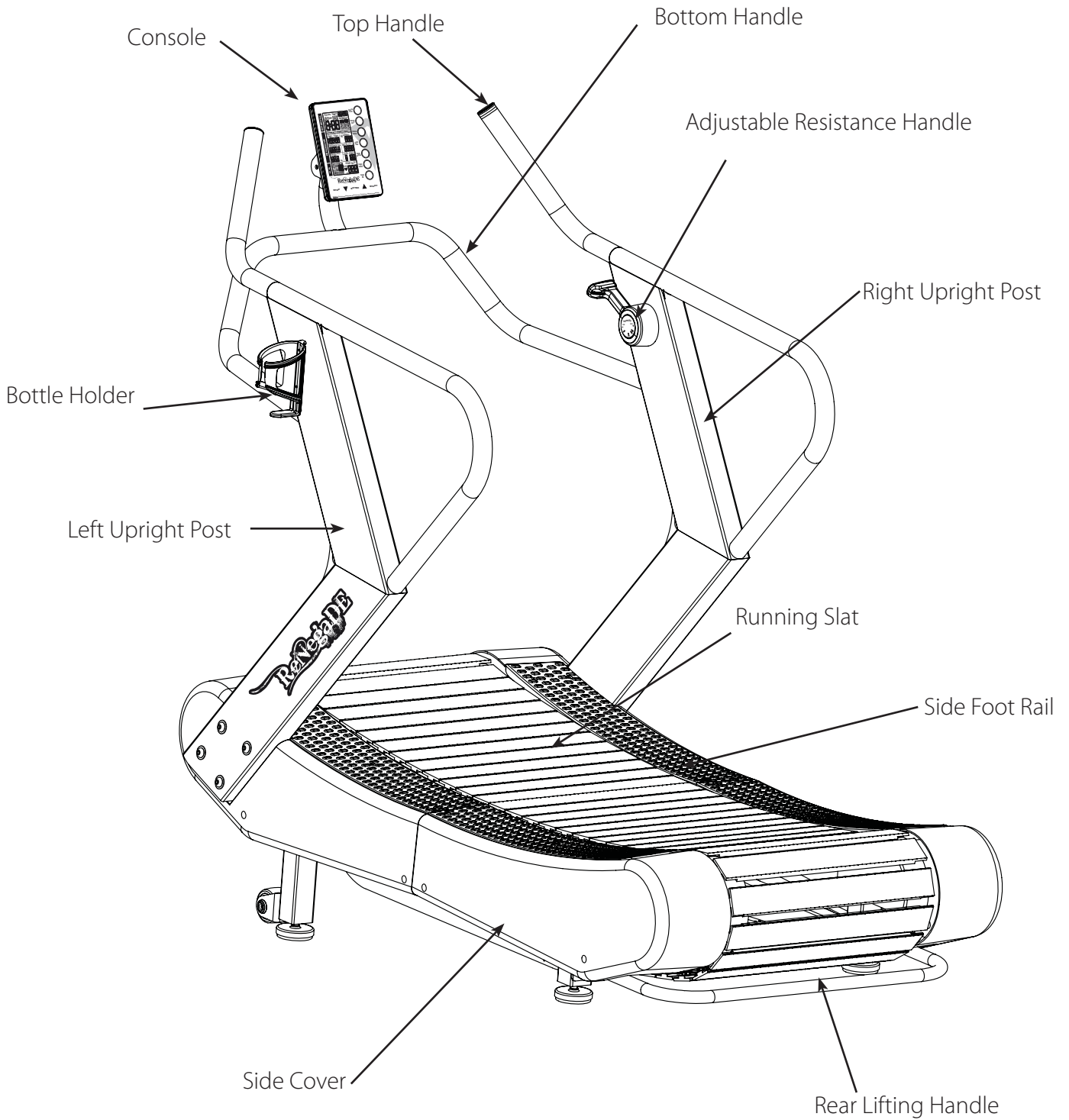

Main Parts

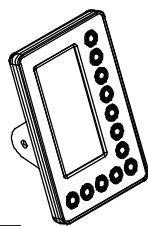

Part No. 5 Console

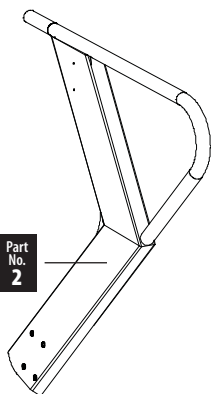

Part No. 2

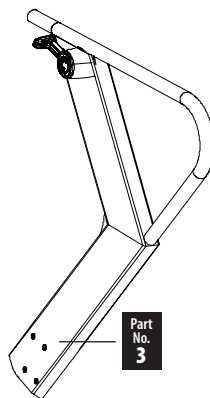

Part No. 3

Left / Right Upright Posts

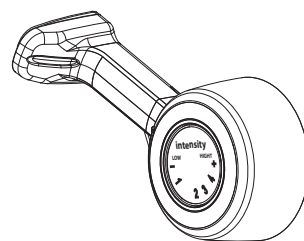

Part No. 68 Magnetic / Resistance Adjustable Handle

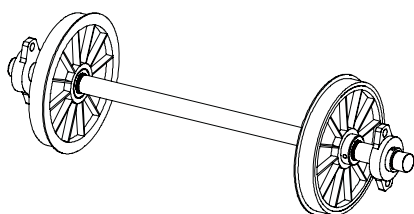

Part No. 30 Front Roller Assembly

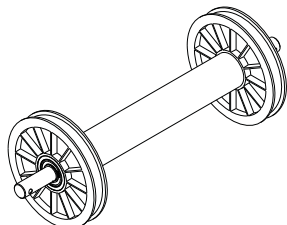

Part No. 64 Rear Roller Assembly

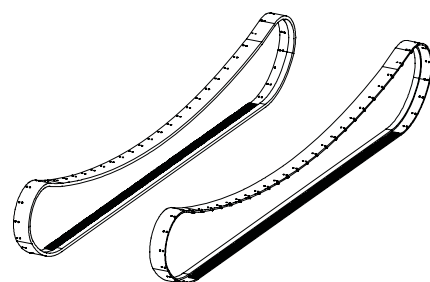

Part No. 27 Running Belt

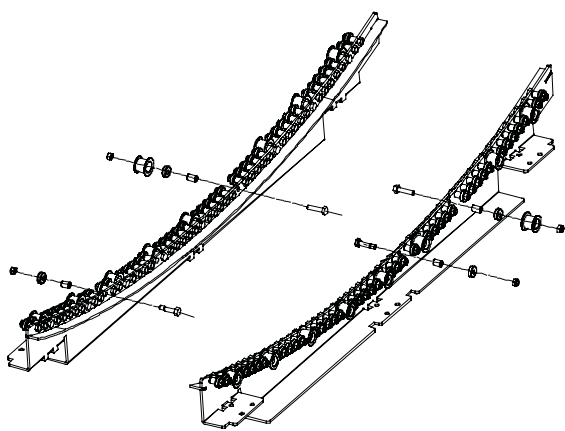

Curve Bearing Trajectory Assembly

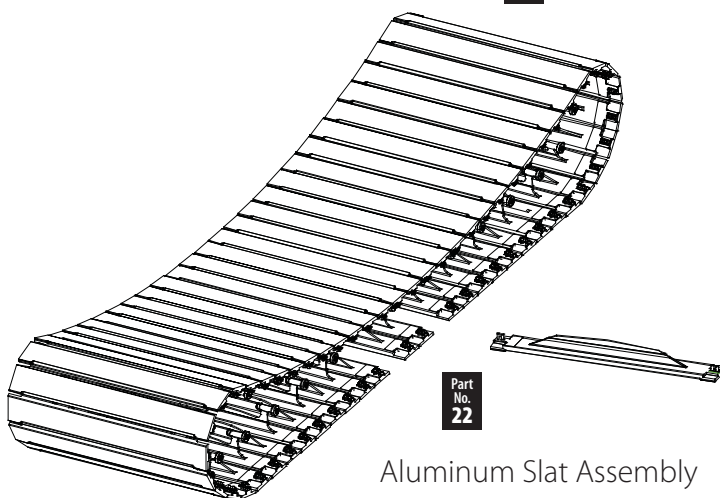

Part No. 22

Aluminum Slat Assembly

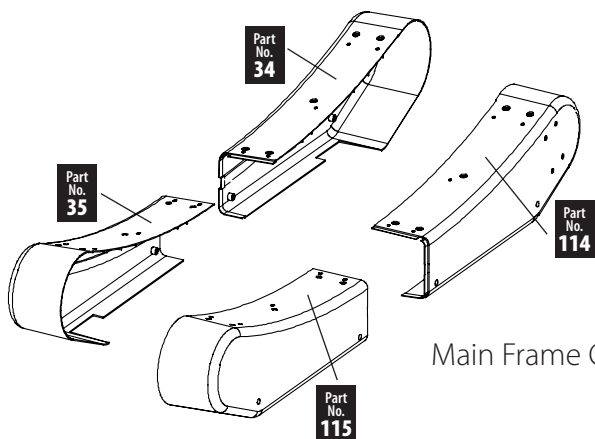

Part No. 34

Part No. 35

Part No. 114

Part No. 115

Main Frame Covers

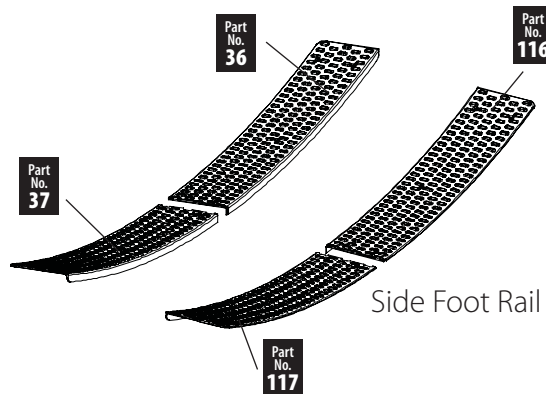

Part No. 36

Part No. 37

Part No. 117

Part No. 116

Side Foot Rail

Exploded Diagram

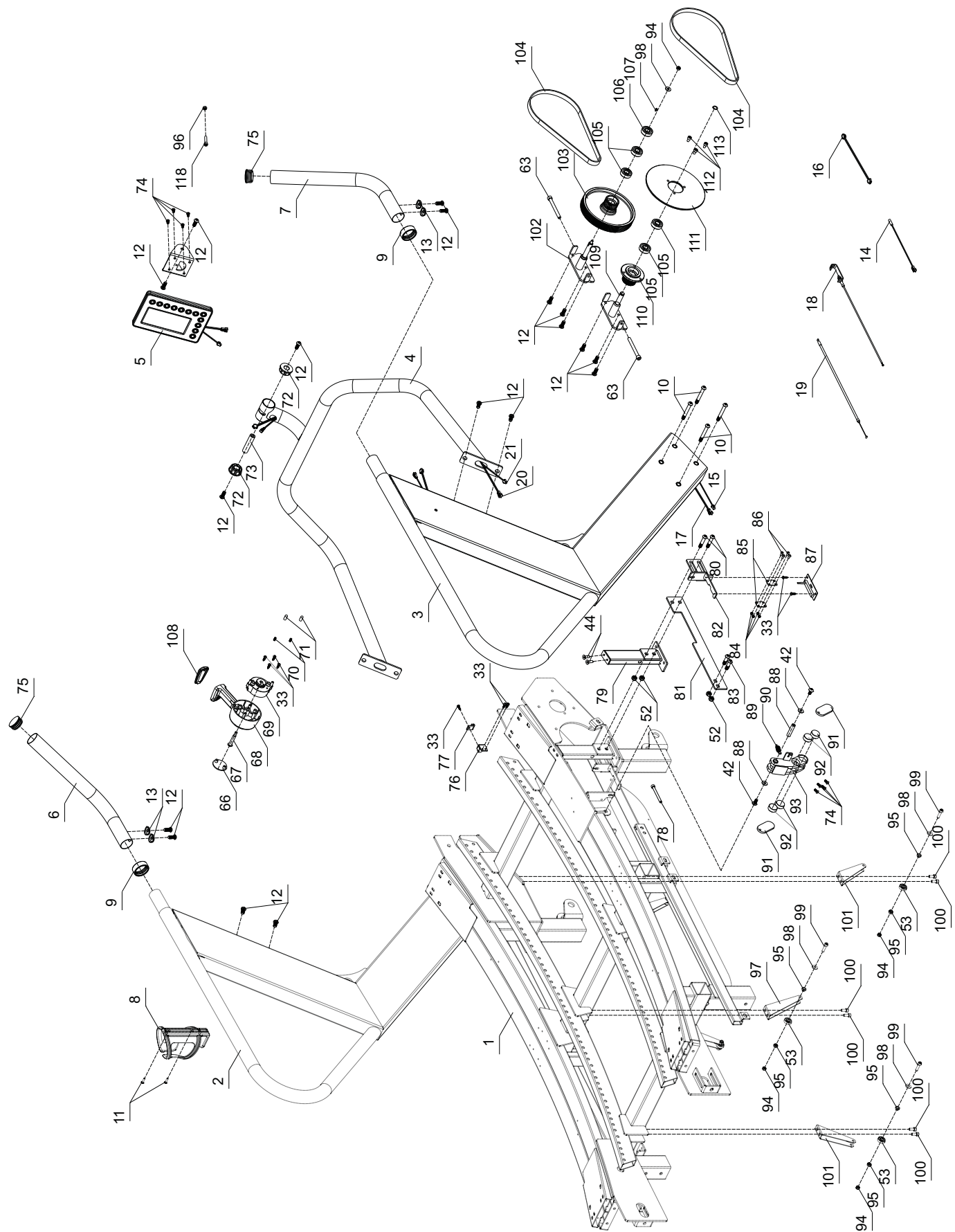

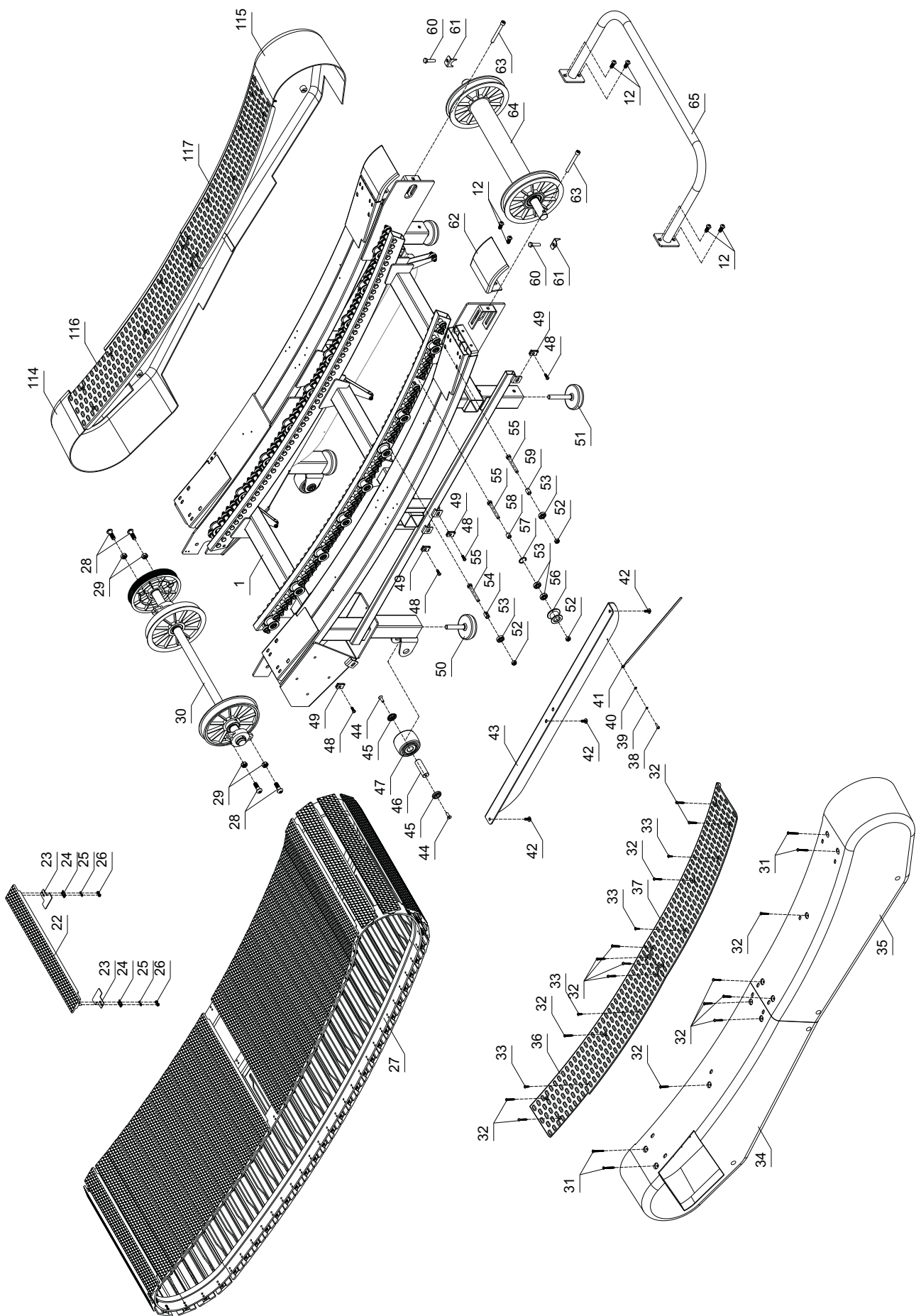

Parts List

No.	Description	Q'ty	No.	Description	Q'ty
1	Main Frame	1	60	Hexagon head full thread bolt - M8 x 30	2
2	Upright post - left side	1	61	Rear roller assembly adjustable fixing plate	2
3	Upright post - right side	1	62	Reinforcement rear covered plate	2
4	Bottom handle bar assembly	1	63	Hexagon socket head full thread screw - M8 x 75	4
5	Console	1	64	Rear roller assembly - Φ 190 x 564.5 367	1
6	Left top handle	1	65	Rear main frame lifting handle	1
7	Right top handle	1	66	Manual resistance adjustable handle top cover	1
8	Bottle holder	1	67	Allen head shoulder bolt - M6 x 50 x 36	1
9	Tube Reducer Ring - Φ 45 x 16	2	68	Manual adjustable handle - 163 x 86 x 59.2	1
10	Allen head C.K.S half thread bolt - M8 x 60 x 20	8	69	Manual resistance adjustable level bracket	1
11	Phillip head C.K.S full thread screw - M4 x 16	2	70	Metal spring - Φ 3.7 x Φ 5.3 x 10	2
12	Allen head C.K.S half thread bolt - M8 x 20	26	71	Manual resistance adjustable level fixing pin	2
13	Curve washer - Φ 8.5 x R25 x t2.0	4	72	Plastic reducer cap - Φ 38 x 15.4	2
14	2 pin -plug bottom section connected wire L-550mm	1	73	Metal sleeve (OD15mm x 63mm)	1
15	2 pin-socket middle section connected wire L-1350mm	1	74	Phillip head C.K.S full thread screw - M5 x 10	8
16	3 pin - socket bottom section connected wire L- 550mm	1	75	End cap - Φ 38 x t1.5	2
17	3 pin-plug middle section connected wire L- 1350mm	1	76	Metal sensor fixing plate	1
18	Bottom section resistance cable L- 450mm	1	77	Plastic sensor fixing bracket	1
19	Top section resistance cable L - 1100mm	1	78	Hexagon socket head full thread screw - M6 x 60	1
20	3 pin-socket top section connected wire L- 1050mm	1	79	Front support post assembly - right	1
21	2 pin-plug top section connected wire L-1050mm	1	80	Allen head C.K.S half thread bolt - M8 x 40 x 20	2
22	Aluminum slat - 478 x 59.3 x 28	60	81	Main frame reinforcement plate - front	1
23	EVA space pad - 50 x 48 x t1.5	120	82	Adjustable resistor fixing bracket	1
24	Metal fixing plate - t1.5 x 20 x 14.3	120	83	Allen head C.K.S half thread bolt - M8 x 30 x 20	2
25	Star washer - Φ 6	240	84	Hex head locknut - M4	4
26	Hex head locknut - M5	240	85	Adjustable resistor fixing plate	2
27	Running belt - 3600 x 50 x 9.5 x 5	2	86	Phillip head C.K.S full thread screw - M4 x 10	4
28	Allen head C.K.S full thread bolt - M10 x 30 x 20	4	87	Adjustable resistor -VR assembly	1
29	Hex head locknut - M10	4	88	Flat washer - Φ 6 x Φ 20 x t2.0	2
30	Front roller assembly - Φ 187 x 652 x 371 x 31	1	89	Metal spring - Φ 10 x Φ 1.2 x 25	1
31	Phillip head C.K.S self-taping screw - ST4 x 40	8	90	Metal sleeve - Φ 10 x 43	1
32	Phillip head C.K.S self-taping screw - ST4 x 30	32	91	Magnet covered plate	2
33	Phillip head C.K.S self-taping screw - ST4 x 16	17	92	Round magnet - 25 x 25 x 10	4
34	Front plastic side cover -Left - 851 x 160 x 307	1	93	Adjustable magnet bracket	1
35	Rear plastic side cover -Left - 851 x 160 x 307	1	94	Hex head locknut - M6	7
36	Front side foot rail - Left - 671 x 141 127	1	95	Bushing - Φ 12 x Φ 7.9 x Φ 6 x 6.5	12
37	Rear side foot rail - Left - 671 x 141 127	1	96	Hex nut - M6	1
38	Phillip head C.K.S full thread screw - M4 x 16	1	97	Metal clamp - center position	2
39	Spring washer - Φ 5	1	98	Metal flat washer - Φ 6	7
40	Star washer - Φ 5	1	99	Hexagon socket head full thread screw - M6 x 25	6
41	Earthing cable - L300mm	1	100	Hexagon socket head full thread screw - M6 x 15	12
42	Allen head C.K.S full thread bolt - M6 x 15	8	101	Metal clamp - front & rear ends	4
43	Main frame bottom fixing plate	2	102	Pulley wheel axle weldment -front	1
44	Hexagon countersunk head full thread screw - M6 x 15	6	103	Driving pulley wheel -front - Φ 158 x Φ 40 x Φ 32 x 52	1
45	Front moving wheel cover - t1.2 x Φ 31	4	104	Driving ribbed belt - 6EPJ290	2
46	Metal sleeve - Φ 19 x 60 x M6	2	105	Deep groove ball bearing - 6201ZZ	4
47	Moving wheel - Φ 71 x t48 x Φ 19.2	2	106	One way bearing - CSK12P	1
48	Phillip head C.K.S full thread screw - M5 x 15	8	107	Metal SQ fixing pin - 9 x 4 x 4	1
49	Multi-thread lugnut - 24 x 16 x 8.3 x M5	8	108	Manual adjustable handle top cap - 59.2 x 12.6.x 36.2	1
50	Front foot stop - Φ 74 x 86 x M12	2	109	Pulley wheel axle weldment -rear	1
51	Height adjustable foot stop - rear - Φ 75 x 102 x M12	2	110	Pulley wheel assembly - rear - Φ 70 x Φ 40 x Φ 32 x 38	1
52	Hex head locknut - M8	112	111	Driving wheel plate -Aluminum - Φ 180 x Φ 45.3 x 4	1
53	Bearing - 608zz	132	112	Allen head C.K.S full thread bolt - M6 x 10	3
54	Metal Sleeve w/ Notch (OD12mm x ID8.1mm x16mm)	36	113	Metal clip - Φ 12	1
55	Hexagon head half thread bolt - M8 x 60 x 13	108	114	Front plastic side cover - Right - 851 x 160 x 307	1
56	Guiding pulley wheel -Aluminum	18	115	Rear plastic side cover - Right - 851 x 160 x 307	1
57	Metal clip - Φ 23	18	116	Front side foot rail - Right - 671 x 141 127	1
58	Metal sleeve (OD12mm x ID8.1mm x12mm)	18	117	Rear side foot rail - Right - 671 x 141 127	1
59	Metal sleeve (OD12mm x ID8.1mm x16mm)	54	118	Hexagon head full thread bolt - M6 x 30	1

Your Warranty

This product is supplied with a 1 year warranty as follows:

This product is warranted for use in a commercial environment

This warranty excludes damage to the finish of the machine, damage sustained as a result form neglect, abuse, or failure to follow the suggested maintenance requirements (see Maintanance), shipping charges and if applicable, labor for the installation of any parts shipped to the owner under this warranty.

Please Note: Warranty details may vary from one market area to another

Warranty Terms

We warrants that the Product you have purchased from an authorised reseller is free from defects in materials and workmanship. The Warranty is valid subject to normal and reasonable use in the environment as described above, and correct assembly of the product during the warranty period. The warranty period extends to the original purchaser only. It is not transferable to anyone who subsequently purchases the Product from you.

The warranty excludes normal wear and tear on parts.

Your sales receipt, showing the date of purchase of the product, is your proof of the date of purchase.

This warranty becomes valid only if the Product is assembled / installed according to the instructions / directions included with the product. This warranty does not extend to any product that has been damaged or rendered defective: (a) as a result of accident, misuse, abuse or lack of reasonable care; (b) by the use of parts not manufactured by us or sold by us by modification of the product; (d) as a result of service by anyone else other than us or an authorised warranty service provider.

During the warranty period we will at no additional charge provide replacement part(s) or repair the product (at our option) if it becomes defective, malfunctions or otherwise fails to conform with this warranty under normal, non-commercial, personal, family or household use. In repairing the product, we may replace defective parts or at the option of ours, use serviceable used parts that are equivalent to new parts in performance. All exchanged parts and products replaced under this warranty will become the property of ours. We reserves the right to change manufacturers of any part to cover any existing warranty.

If the product must be returned, you must return the Product or defective part to us in its original container (or equivalent) with Proof of Purchase. Any evidence of alteration, erasing or forgery of proof of purchase documents will be cause to void this warranty. You must prepay any shipping charges and you are responsible for insuring any product or part that is returned. Should any product submitted for warranty service be found to be ineligible, an estimate of repair cost will be furnished and the repair will be made if requested, upon our receipt of payment or acceptable arrangement of payment. Under no circumstances will returns be accepted without return authorisation by our Customer Service department.

To obtain warranty service you must and provide the following information:

Name of Product, Product Code, Batch No, Date Purchased, and Nature of fault or part number required.

Neither dealer of this product nor any retail establishment selling this product has any authority to make any warranties or to promise remedies in addition to, or inconsistent with, those stated above. This warranty does not affect your statutory rights.

Please note that warranty terms may vary from one market area to another

ReNEgade