

SPRINTER ROOF RACK INSTALL

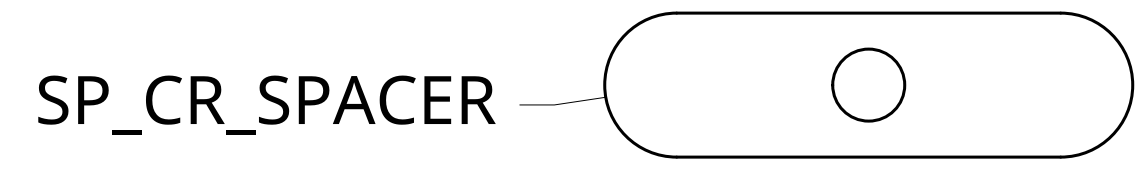
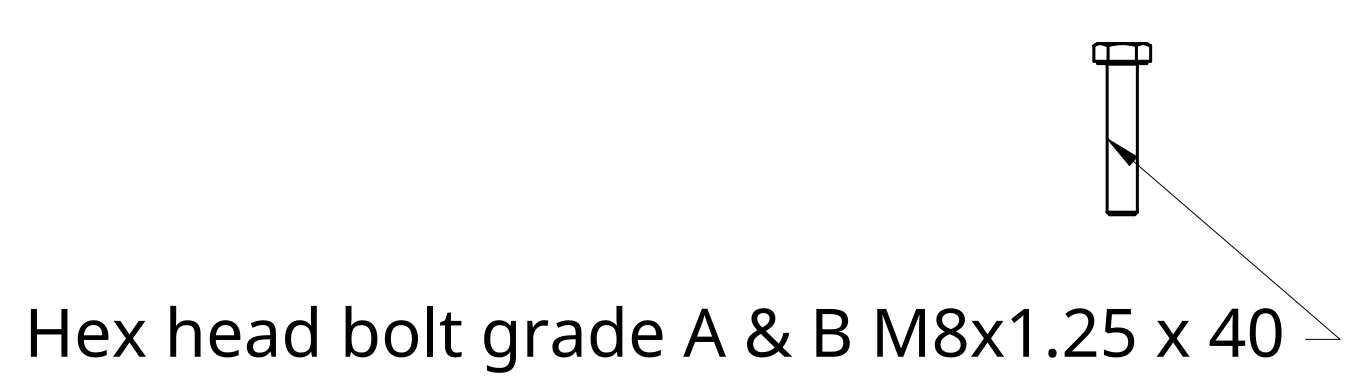
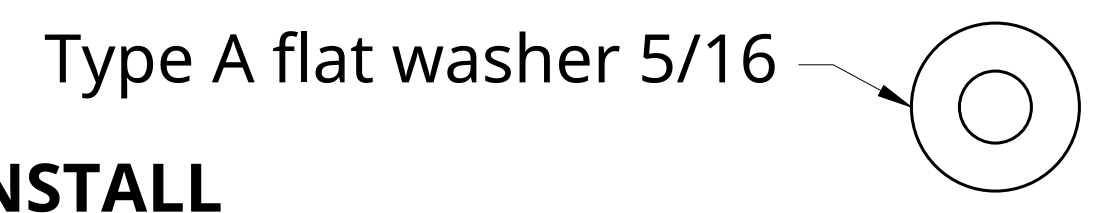
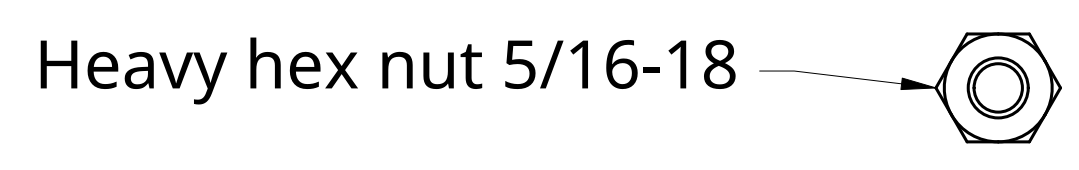
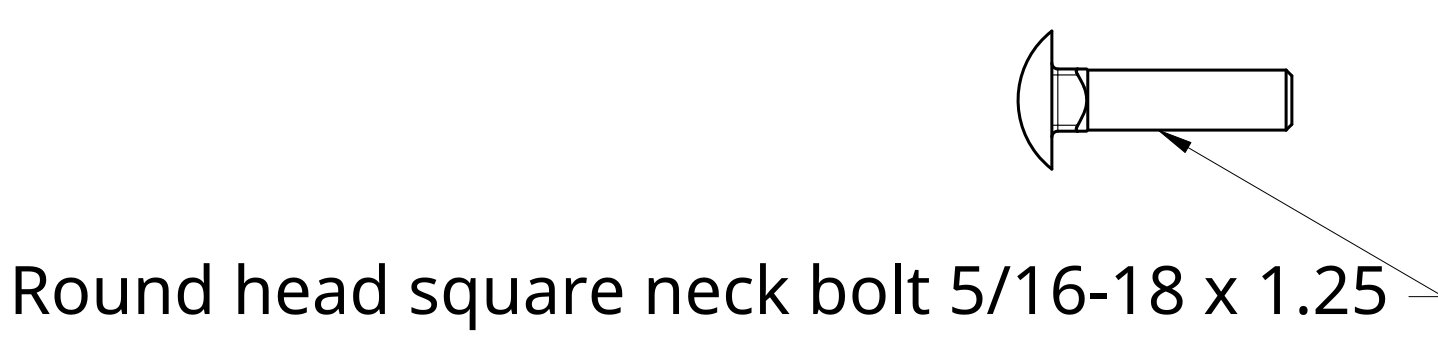
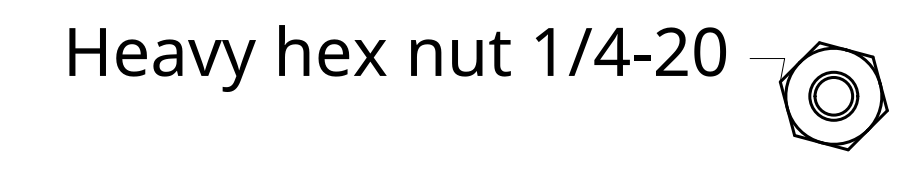
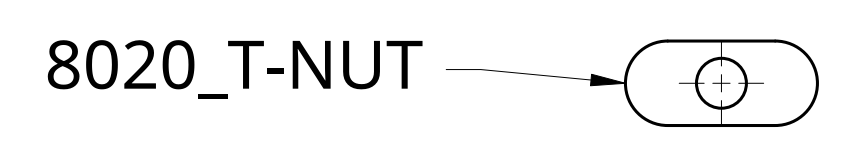
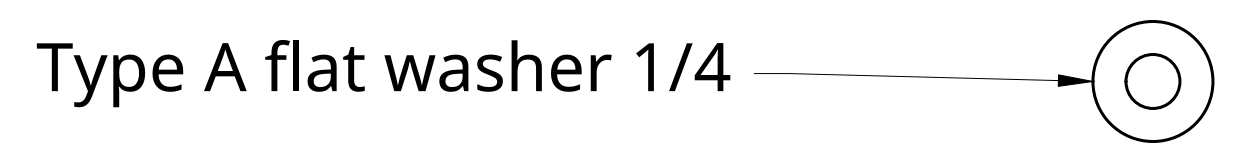
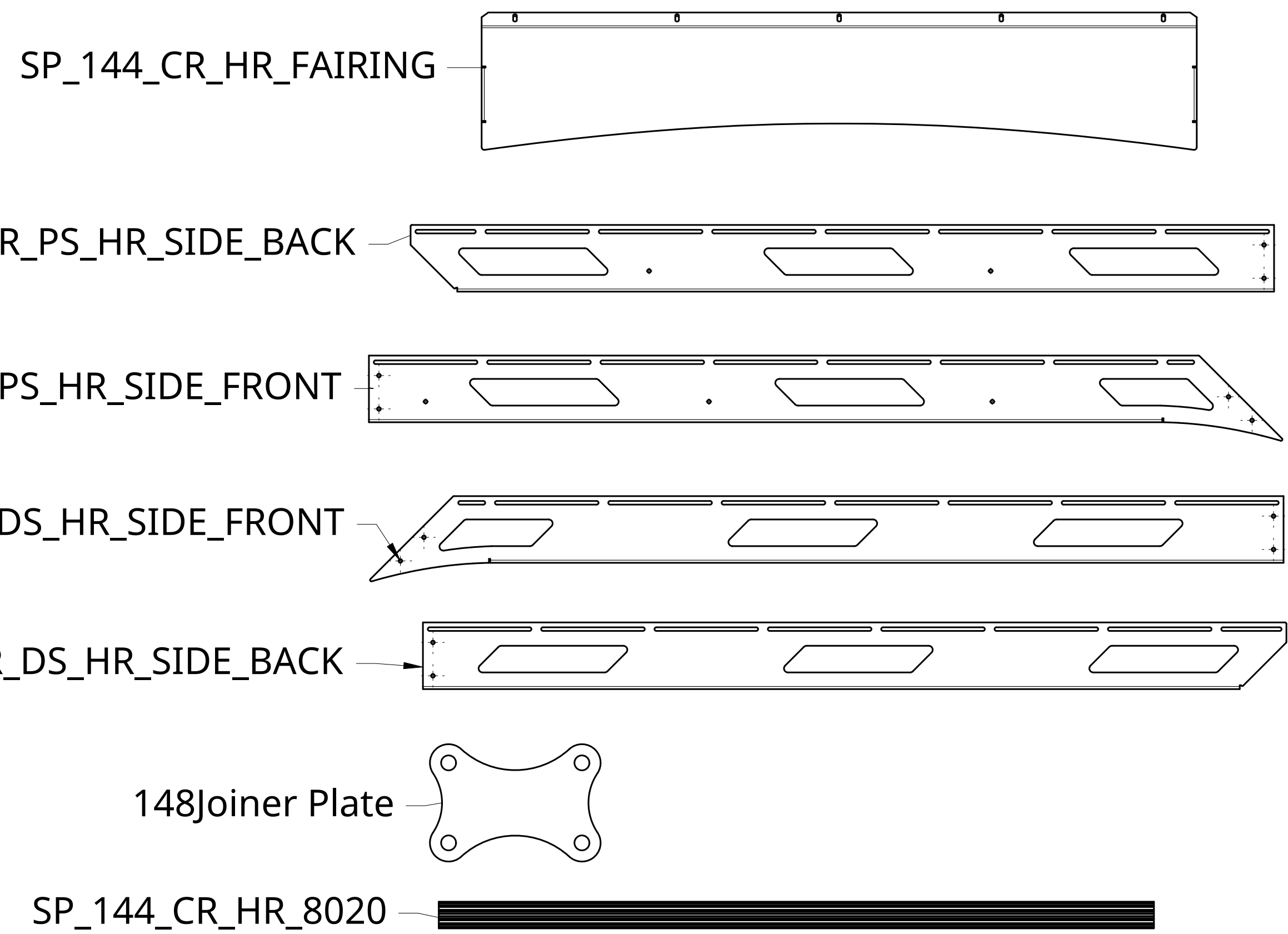

144 WITH RAILS

| Item | Quantity | Name |
|------|----------|--|
| 1 | 1 | SP_144_CR_HR_FAIRING |
| 2 | 1 | SP_144_CR_PS_HR_SIDE_BACK |
| 3 | 1 | SP_144_CR_PS_HR_SIDE_FRONT |
| 4 | 1 | SP_144_CR_DS_HR_SIDE_FRONT |
| 5 | 1 | SP_144_CR_DS_HR_SIDE_BACK |
| 6 | 5 | SP_144_CR_HR_8020 |
| 7 | 2 | 148Joiner Plate |
| 8 | 37 | Type A flat washer 1/4 |
| 9 | 32 | Binding head machine screw 1/4-20 x 1 |
| 10 | 5 | Binding head machine screw 1/4-20 x 0.5 |
| 11 | 5 | 8020_T-NUT |
| 12 | 12 | Heavy hex nut 1/4-20 |
| 13 | 16 | SP_CR_HR_RAIL_WASHER |
| 14 | 16 | Round head square neck bolt 5/16-18 x 1.25 |
| 15 | 16 | Heavy hex nut 5/16-18 |
| 16 | 16 | Type A flat washer 5/16 |

144 WITH NO RAILS

| Item | Quantity | Name |
|------|----------|---|
| 1 | 5 | SP_144_CR_HR_8020 |
| 2 | 1 | SP_144_CR_HR_FAIRING |
| 3 | 1 | SP_144_CR_PS_HR_SIDE_BACK |
| 4 | 1 | SP_144_CR_PS_HR_SIDE_FRONT |
| 5 | 1 | SP_144_CR_DS_HR_SIDE_FRONT |
| 6 | 1 | SP_144_CR_DS_HR_SIDE_BACK |
| 7 | 2 | 148Joiner Plate |
| 8 | 37 | Type A flat washer 1/4 |
| 9 | 32 | Binding head machine screw 1/4-20 x 1 |
| 10 | 5 | Binding head machine screw 1/4-20 x 0.5 |
| 11 | 5 | T-NUT 1/4-20 |
| 12 | 12 | Heavy hex nut 1/4-20 |
| 13 | 19 | Hex head bolt grade A & B M8x1.25 x 40 |
| 14 | 16 | Type A flat washer 5/16 |
| 15 | 16 | M8 RIVNUT |
| 16 | 16 | SP_CR_SPACER |

170E WITH RAILS

| Item | Quantity | Name |
|------|----------|--|
| 1 | 1 | SP_CR_HR_FAIRING |
| 2 | 1 | SP_170E_CR_DS_HR_RAIL_BACK |
| 3 | 1 | SP_170E_CR_DS_HR_RAIL_FRONT |
| 4 | 1 | SP_170E_CR_DS_HR_RAIL_MID |
| 5 | 1 | SP_170E_CR_PS_HR_RAIL_BACK |
| 6 | 1 | SP_170E_CR_PS_HR_RAIL_FRONT |
| 7 | 1 | SP_170E_CR_PS_HR_RAIL_MID |
| 8 | 4 | CR_HR_DOGBONE |
| 9 | 6 | SP_CR_HR_8020 |
| 10 | 45 | Type A flat washer 1/4 |
| 11 | 40 | Binding head machine screw 1/4-20 x 1 |
| 12 | 20 | Heavy hex nut 1/4-20 |
| 13 | 5 | T-slot nut 5/16-20 |
| 14 | 5 | Binding head machine screw 1/4-20 x 0.5 |
| 15 | 22 | SP_CR_HR_RAIL_WASHER |
| 16 | 22 | Round head square neck bolt 5/16-18 x 1.25 |
| 17 | 22 | Type A flat washer 5/16 |
| 18 | 22 | Heavy hex nut 5/16-18 |

170E WITH NO RAILS

| Item | Quantity | Name |
|------|----------|---|
| 1 | 1 | SP_CR_HR_FAIRING |
| 2 | 1 | SP_170E_CR_DS_HR_RAIL_FRONT |
| 3 | 1 | SP_170E_CR_DS_HR_RAIL_MID |
| 4 | 1 | SP_170E_CR_DS_HR_RAIL_BACK |
| 5 | 40 | Binding head machine screw 1/4-20 x 1 |
| 6 | 45 | Type A flat washer 1/4 |
| 7 | 20 | Heavy hex nut 1/4-20 |
| 8 | 4 | CR_HR_DOGBONE |
| 9 | 1 | SP_170E_CR_DS_HR_RAIL_FRONT |
| 10 | 1 | SP_170E_CR_DS_HR_RAIL_MID |
| 11 | 1 | SP_170E_CR_DS_HR_RAIL_BACK |
| 12 | 6 | SP_CR_HR_8020 |
| 13 | 5 | T-slot nut 5/16-20 |
| 14 | 5 | Binding head machine screw 1/4-20 x 0.5 |
| 15 | 22 | SP_CR_SPACER |
| 16 | 22 | Hex head bolt grade A & B M8x1.25 x 40 |
| 17 | 22 | Type A flat washer 5/16 |
| 18 | 22 | M8 RIVNUT |

RAIL INSTALL

NO RAIL INSTALL



INSTALL WITH FACTORY ROOF RAILS

STEP# 1: ASSEMBLE SIDES

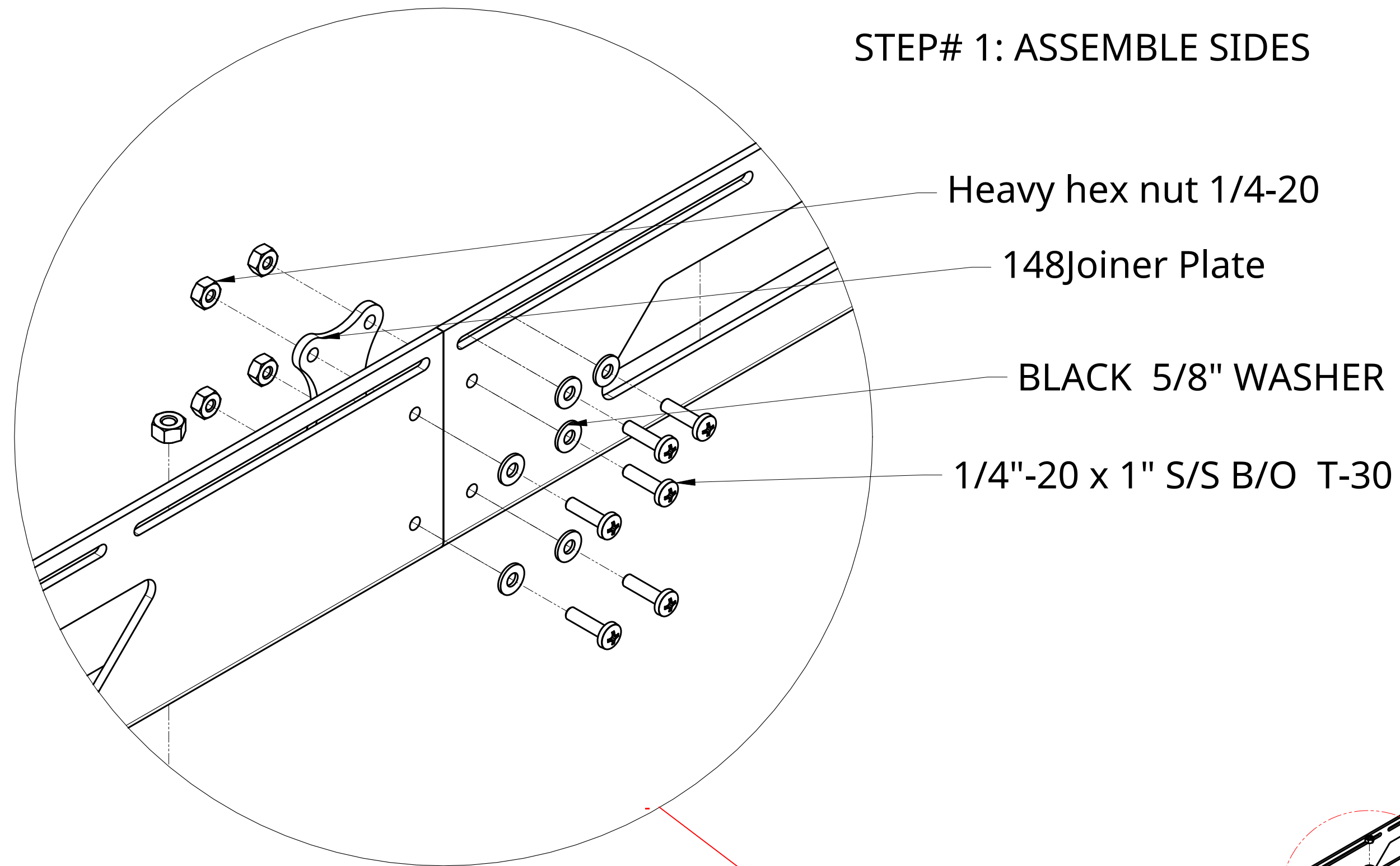

STEP# 2: MOUNT SIDES ON ROOF

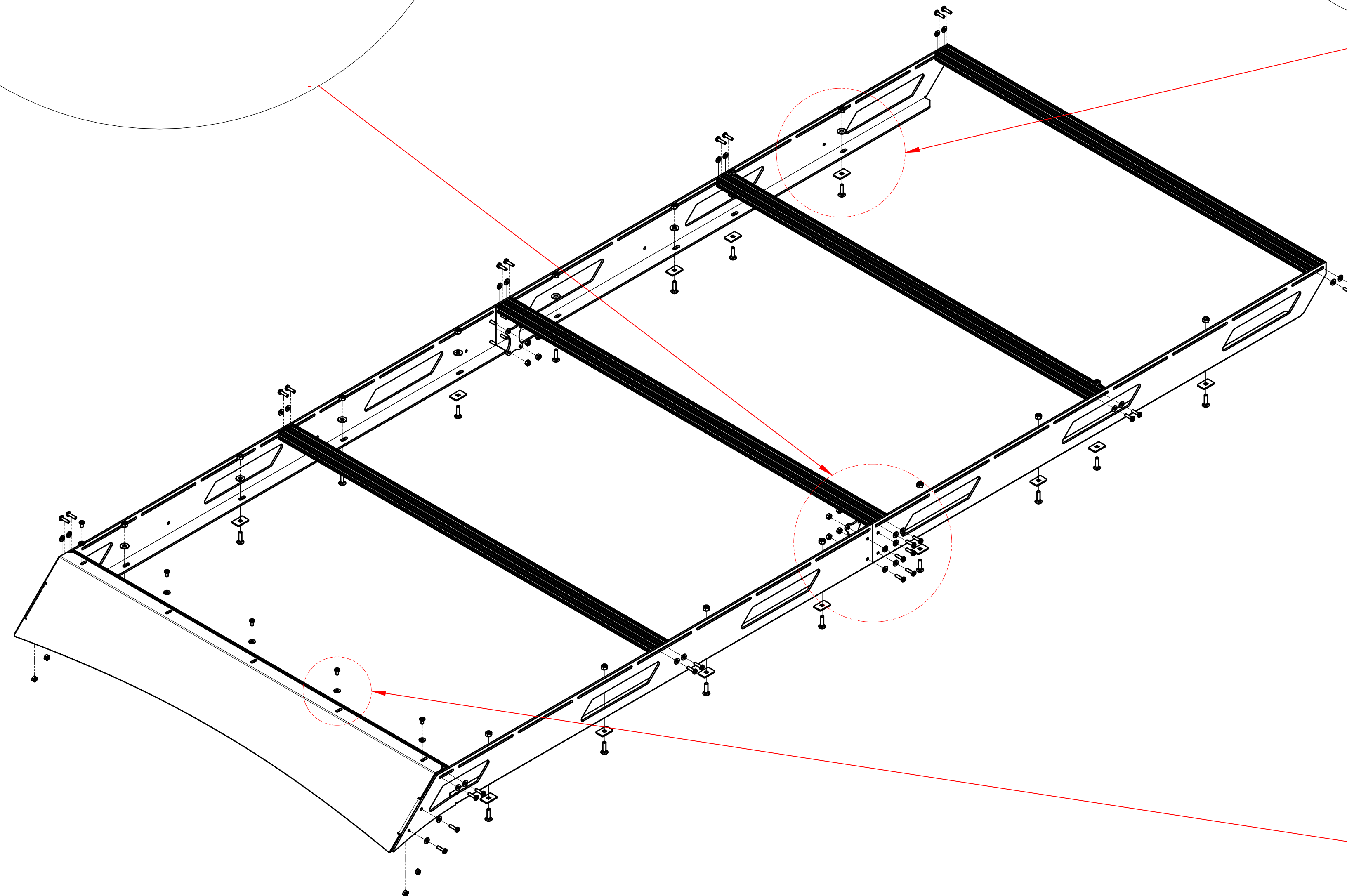
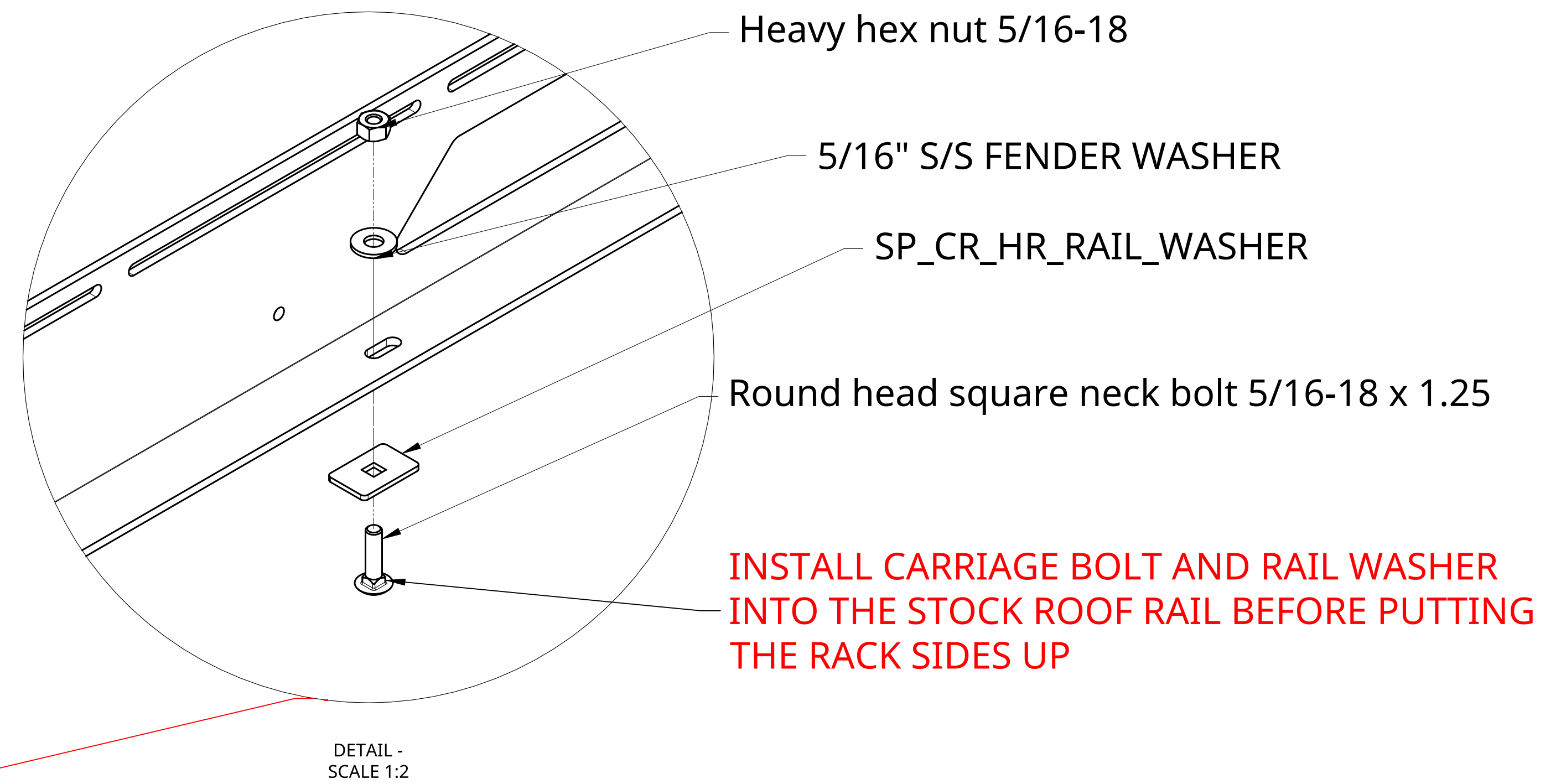

STEP# 3: ATTACH 8020 FAIRING

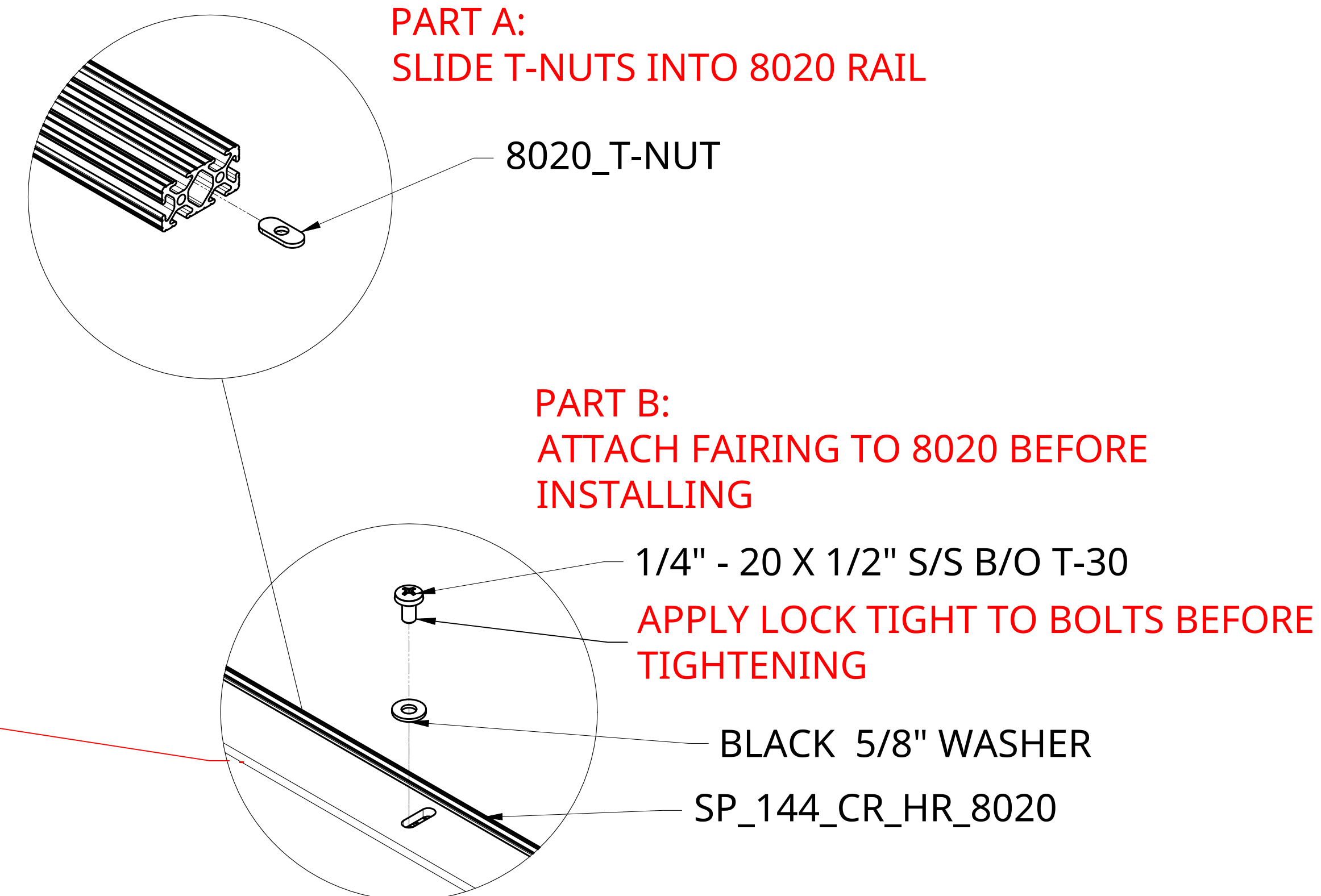

INSTALL WITH NO FACTORY ROOF RAILS

STEP# 2: MOUNT SIDES ON ROOF

STEP# 1: ASSEMBLE SIDES

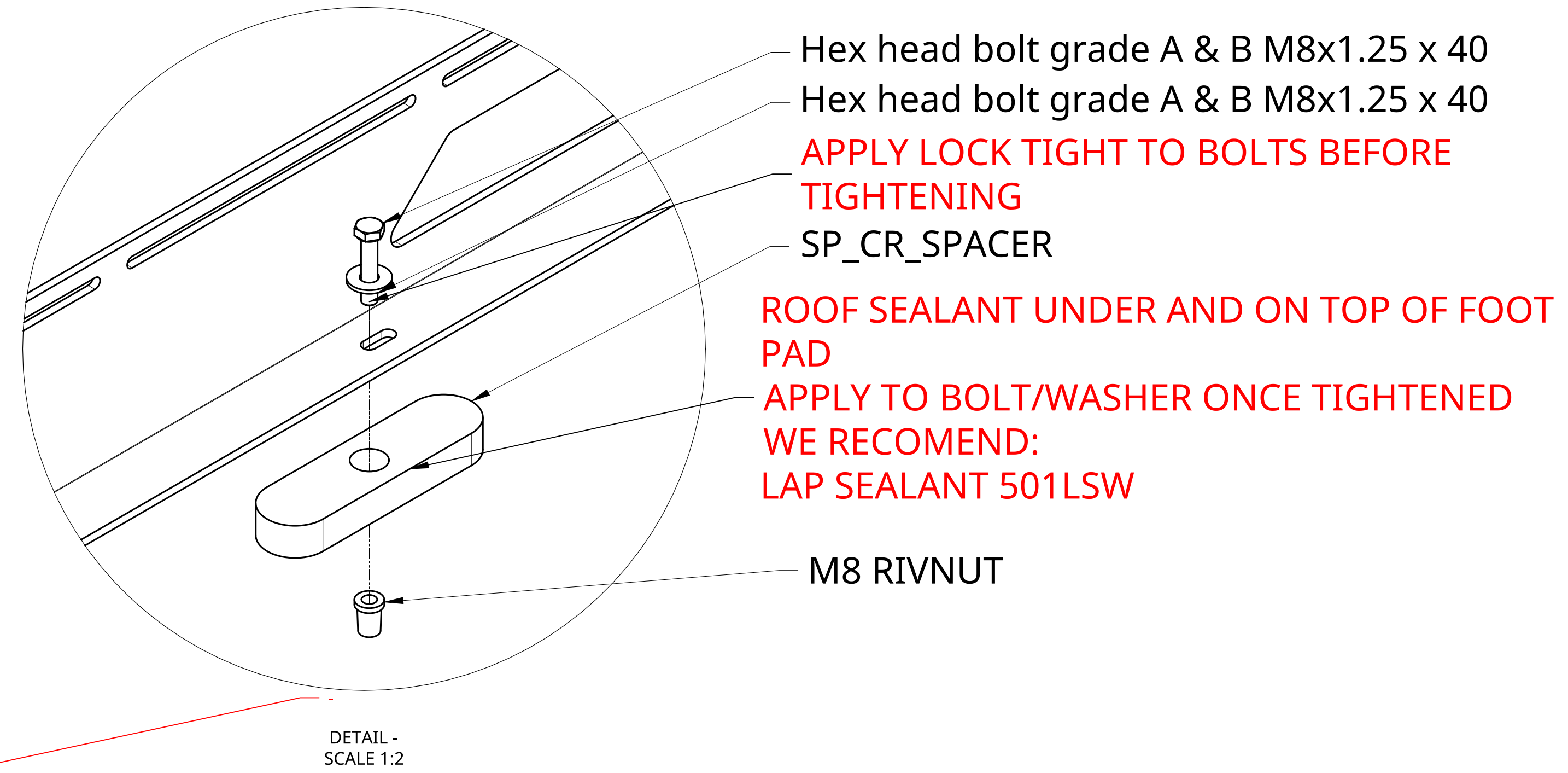
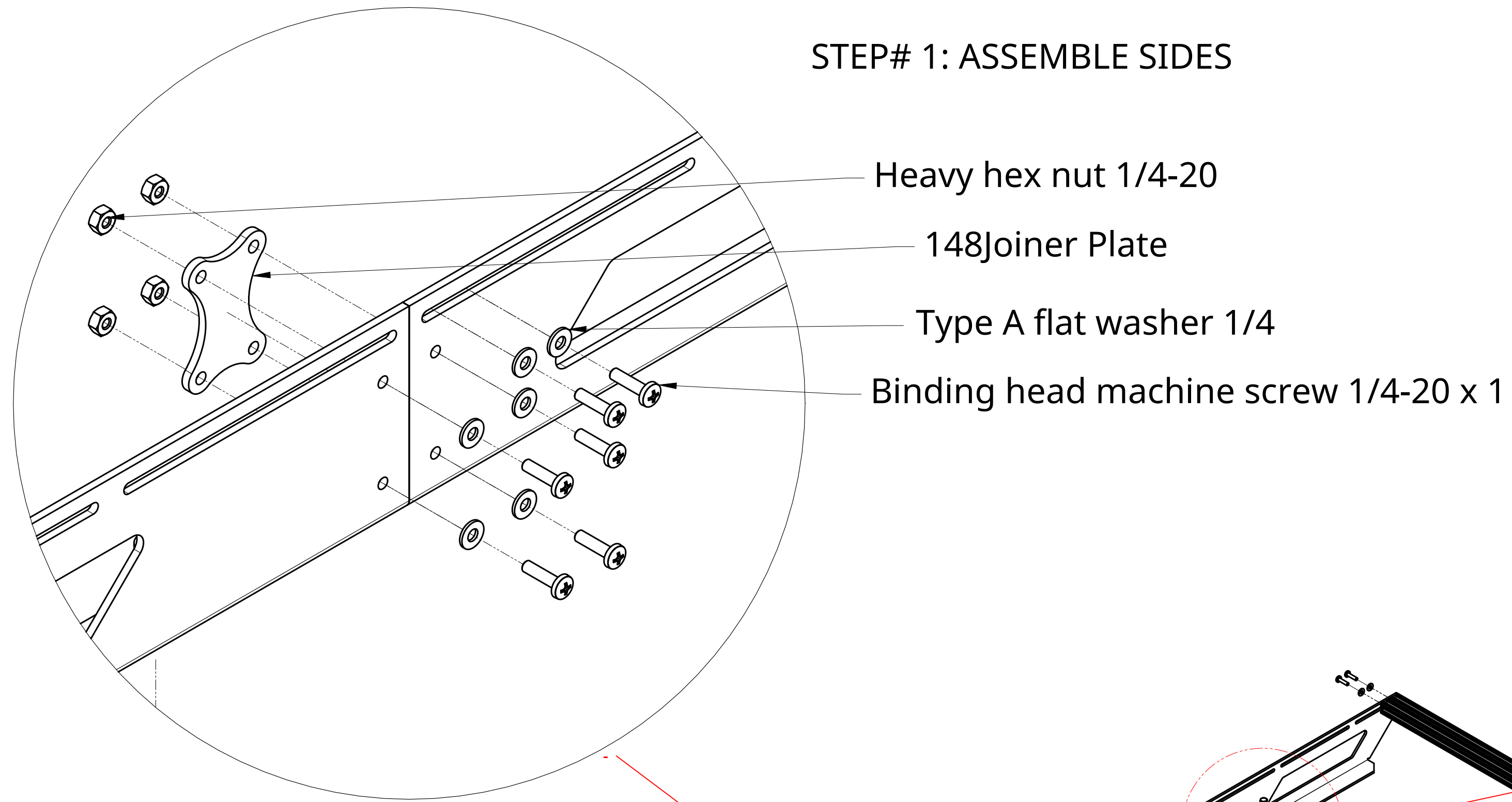

STEP# 3: ATTACH 8020 FAIRING

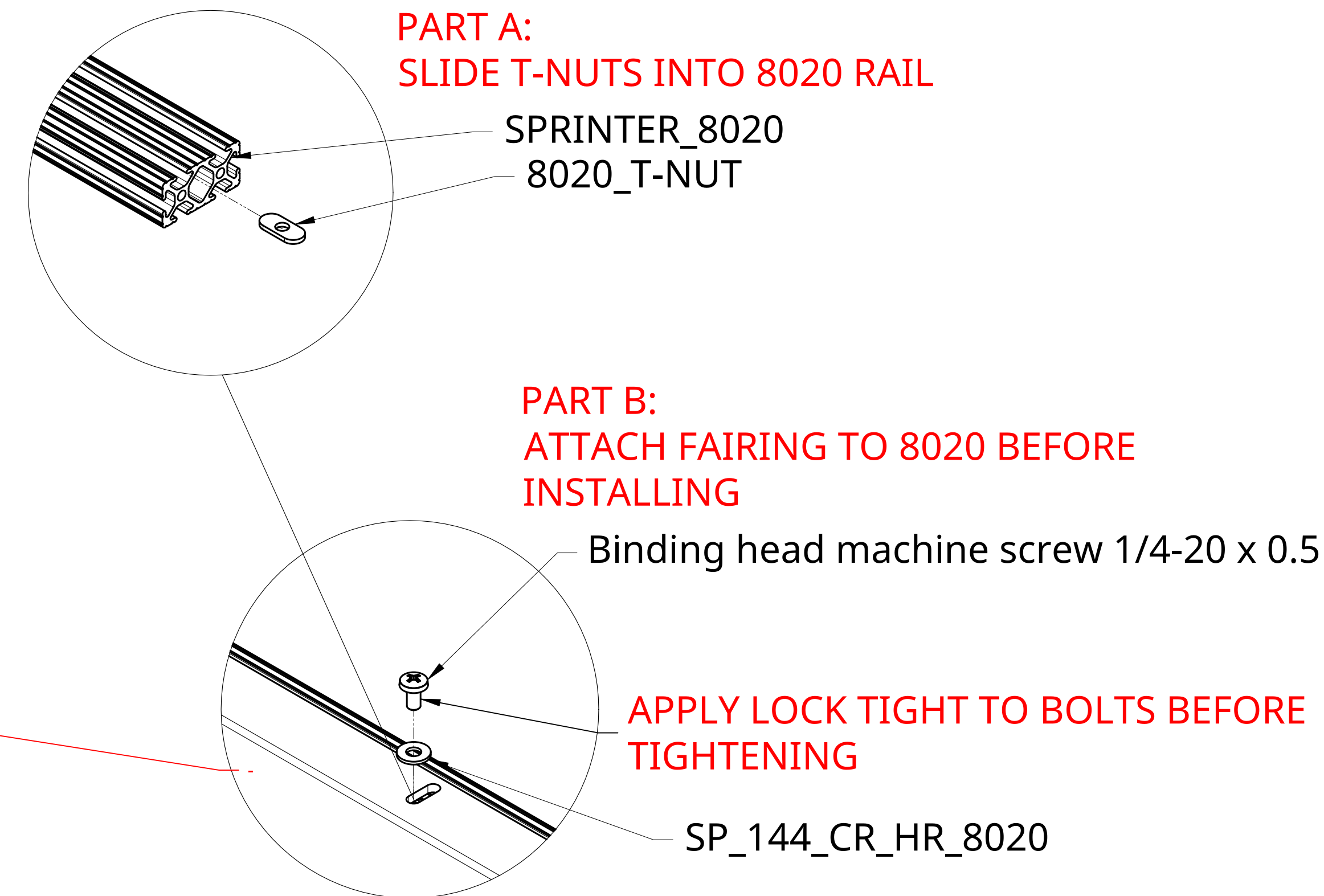

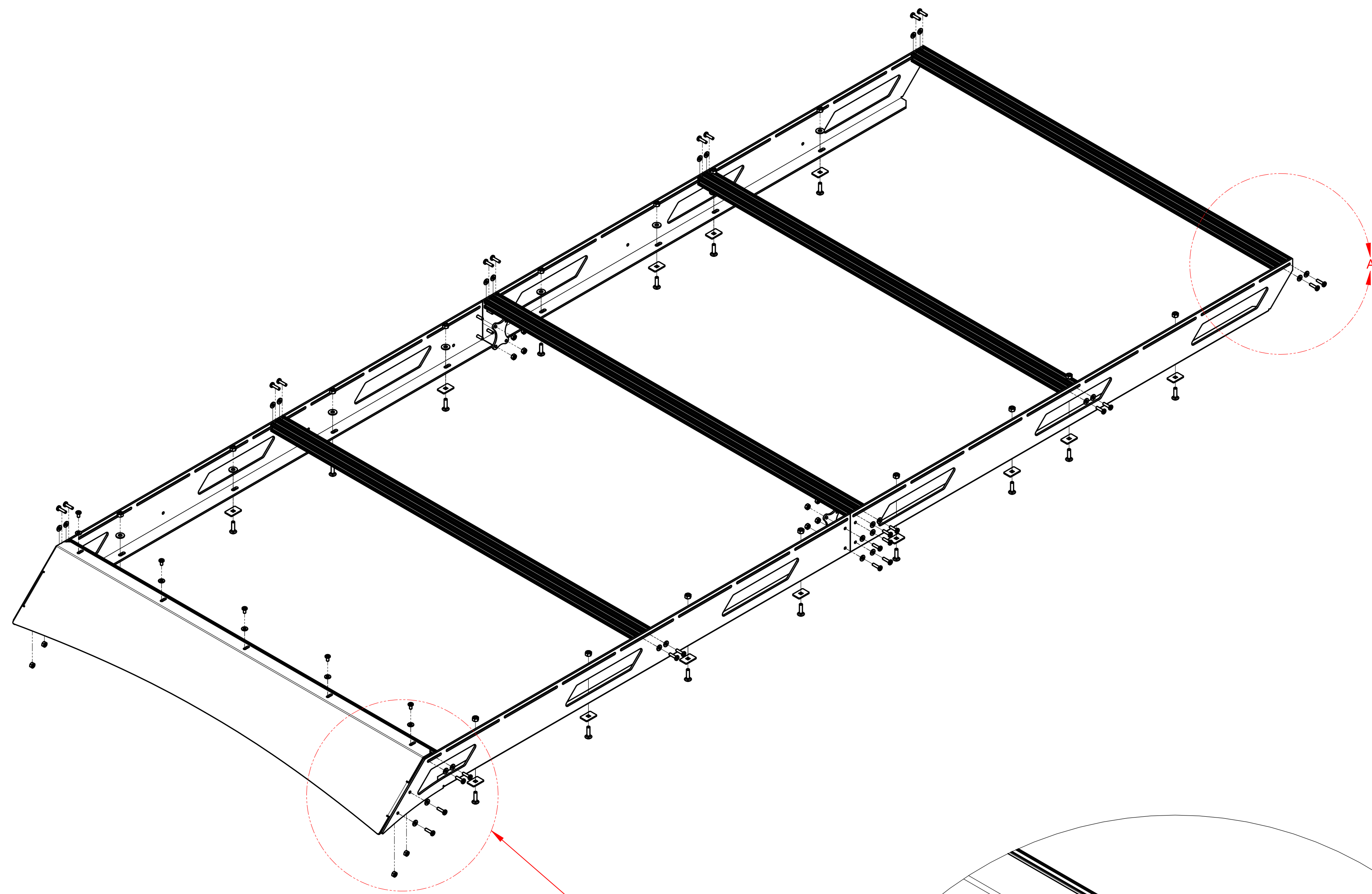

STEP# 5: INSTALLING 8020

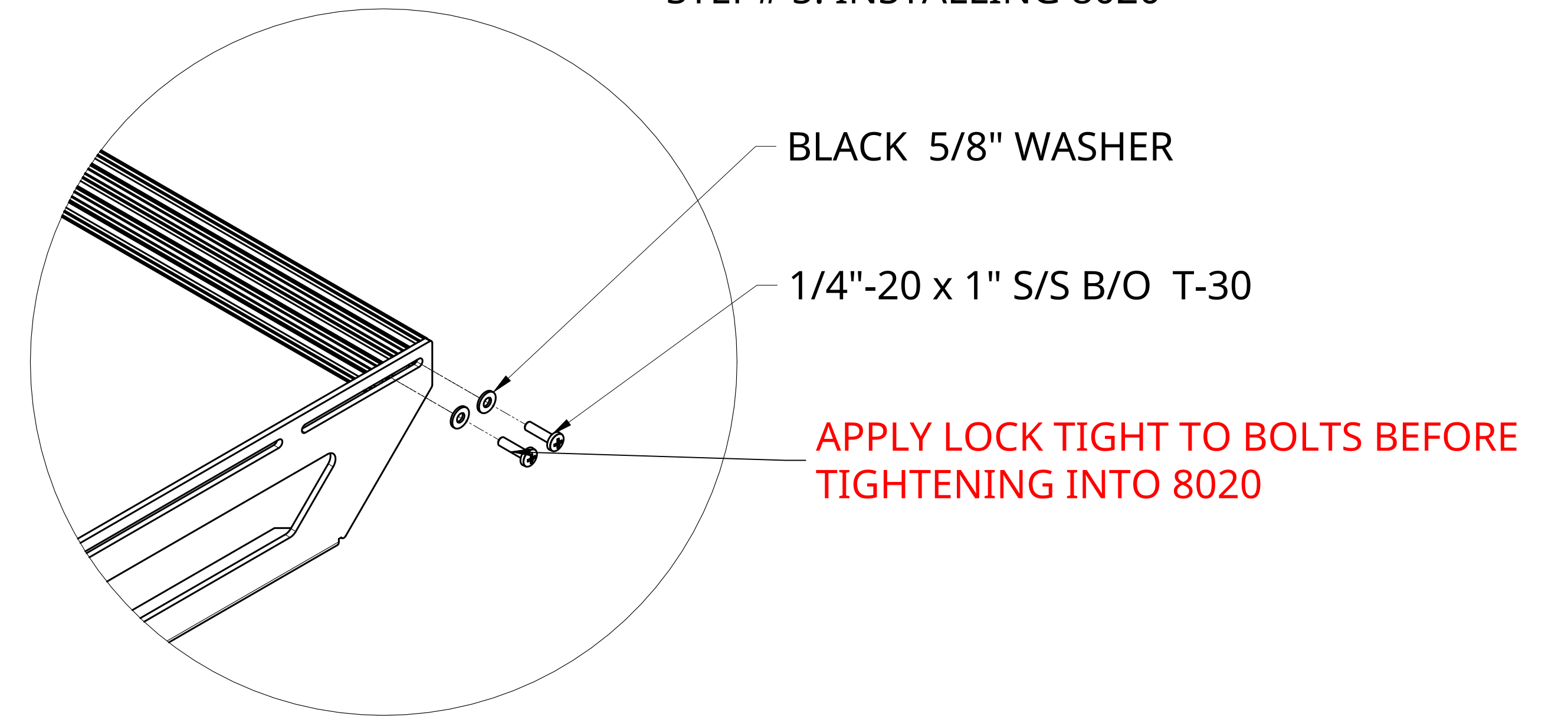

BLACK 5/8" WASHER

1/4"-20 x 1" S/S B/O T-30

APPLY LOCK TIGHT TO BOLTS BEFORE TIGHTENING INTO 8020

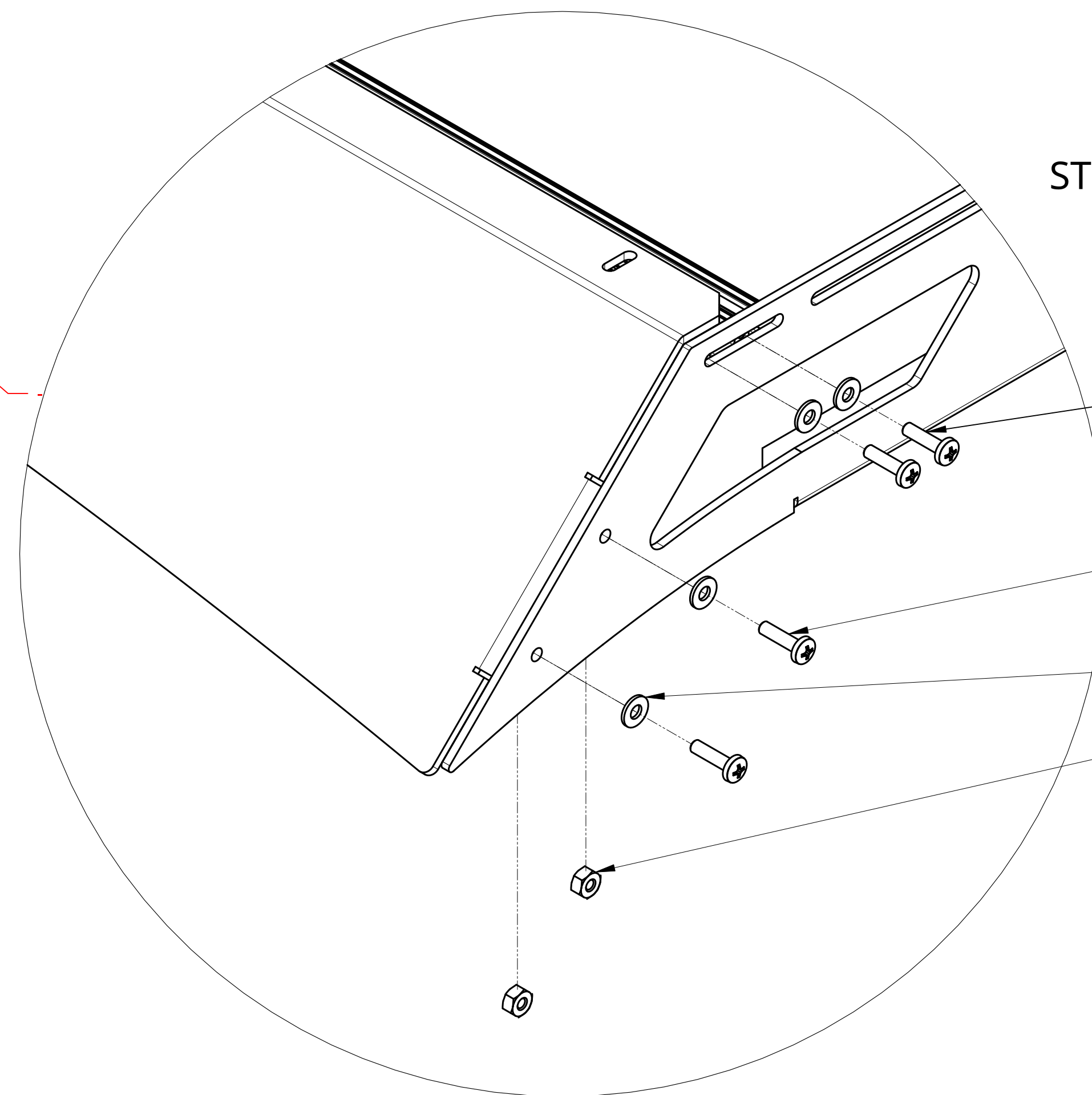

STEP# 4: INSTALL FAIRING

THIS STEP IS MUCH EASIER WITH 2 PEOPLE

APPLY LOCK TIGHT TO BOLTS BEFORE TIGHTENING INTO 8020

1/4"-20 x 1" S/S B/O T-30

BLACK 5/8" WASHER

Nylock Nuts 1/4" - 20

AWNING INSTALL

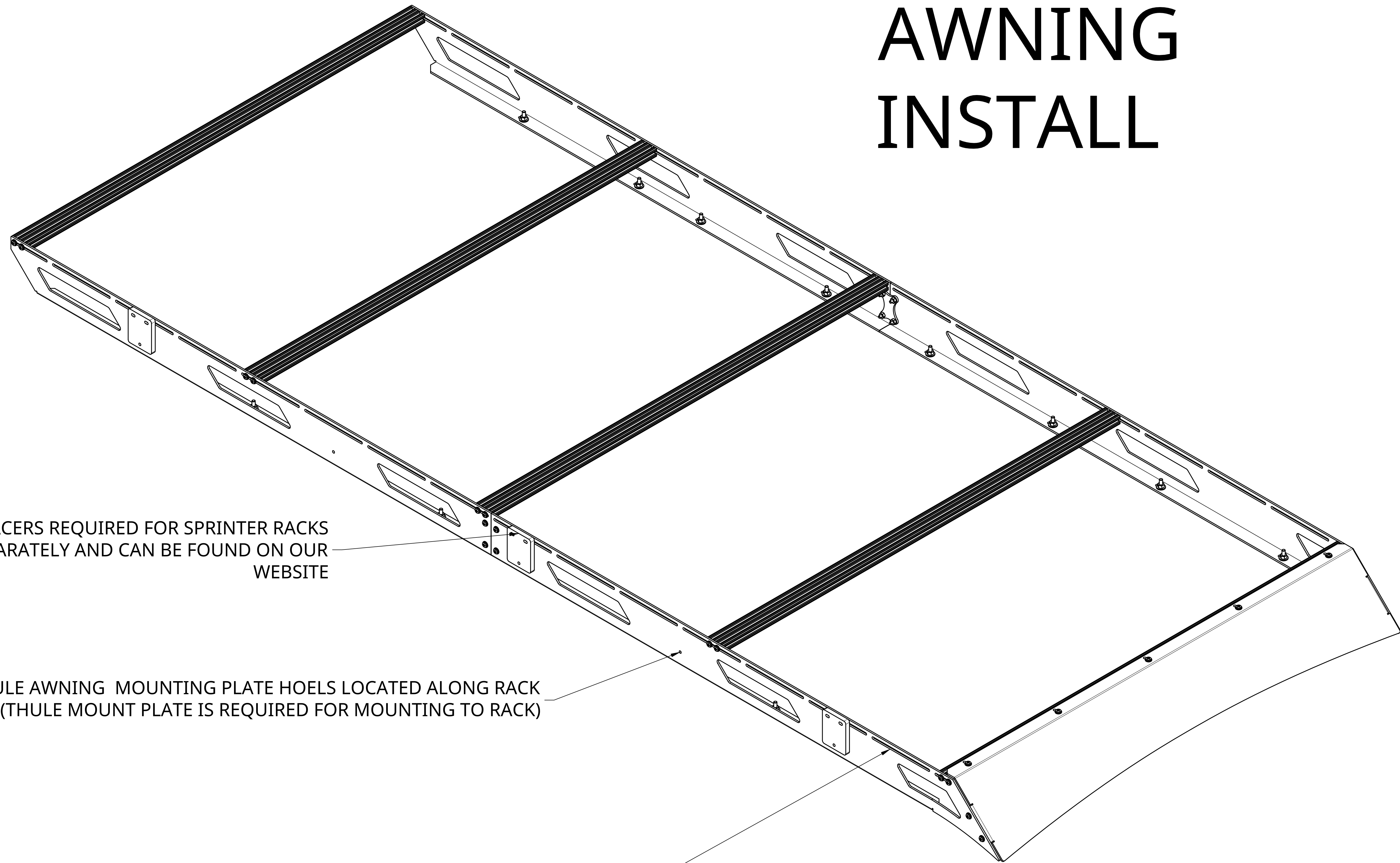

AWNING SPACERS REQUIRED FOR SPRINTER RACKS
THEY ARE SOLD SEPARATELY AND CAN BE FOUND ON OUR
WEBSITE

THULE AWNING MOUNTING PLATE HOELS LOCATED ALONG RACK
(THULE MOUNT PLATE IS REQUIRED FOR MOUNTING TO RACK)

FIAMMA AWNING MOUNTING PLATE CAN BE INSTALLED
ANYWHERE ALONG THE 8020 MOUNTING SLOTS
(FIAMMA MOUNTING PLATE REQUIRED FOR MOUNTING TO RACK)