

SMITH MACHINE S5000

MANUAL DE INSTRUCCIONES

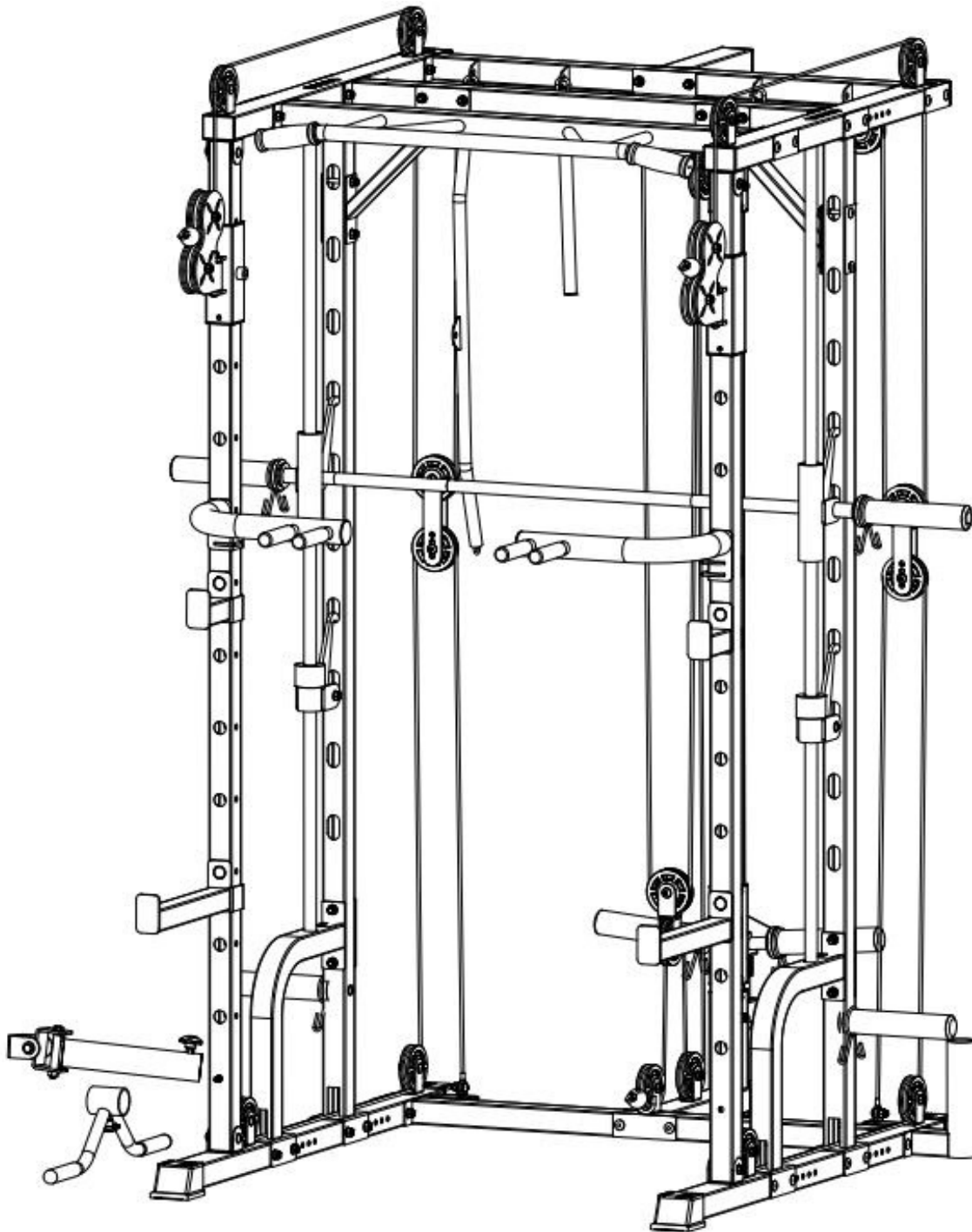

SKU: FT-28006

IMPORTANTE: Lea el Aviso de seguridad importante y la información de montaje en el manual del propietario antes de montar este producto.

AVISO IMPORTANTE DE SEGURIDAD

PRECAUCIONES

Esta máquina de ejercicios está construida para una seguridad óptima. Sin embargo, se aplican ciertas precauciones siempre que opere un equipo de ejercicio. Asegúrese de leer todo el manual antes de ensamblar u operar su máquina. En particular, tenga en cuenta las siguientes precauciones de seguridad:

1. Mantenga a los niños y las mascotas alejados de la máquina en todo momento. NO deje a los niños solos en la misma habitación con la máquina.
2. Solo una persona a la vez debe usar la máquina.
3. Si el usuario experimenta mareos, náuseas, dolor de pecho o cualquier otro síntoma anormal, DETENGA el entrenamiento de inmediato. CONSULTE A UN MÉDICO INMEDIATAMENTE.
4. Coloque la máquina sobre una superficie despejada y nivelada. NO use la máquina cerca del agua o al aire libre.
5. Mantenga las manos alejadas de todas las piezas móviles.
6. Siempre use ropa deportiva adecuada cuando haga ejercicio. No vistas batas u otra ropa que pueda quedar atrapada en la máquina.
7. Use la máquina solo para el uso previsto como se describe en este manual. NO use accesorios no recomendados por el fabricante.
8. No coloque ningún objeto afilado alrededor de la máquina.
9. Las personas discapacitadas no deben usar la máquina sin una persona calificada o médico de turno.
10. Antes de usar la máquina para hacer ejercicio, siempre haga ejercicios de estiramiento para calentar adecuadamente.
11. Nunca utilice la máquina si no funciona correctamente.

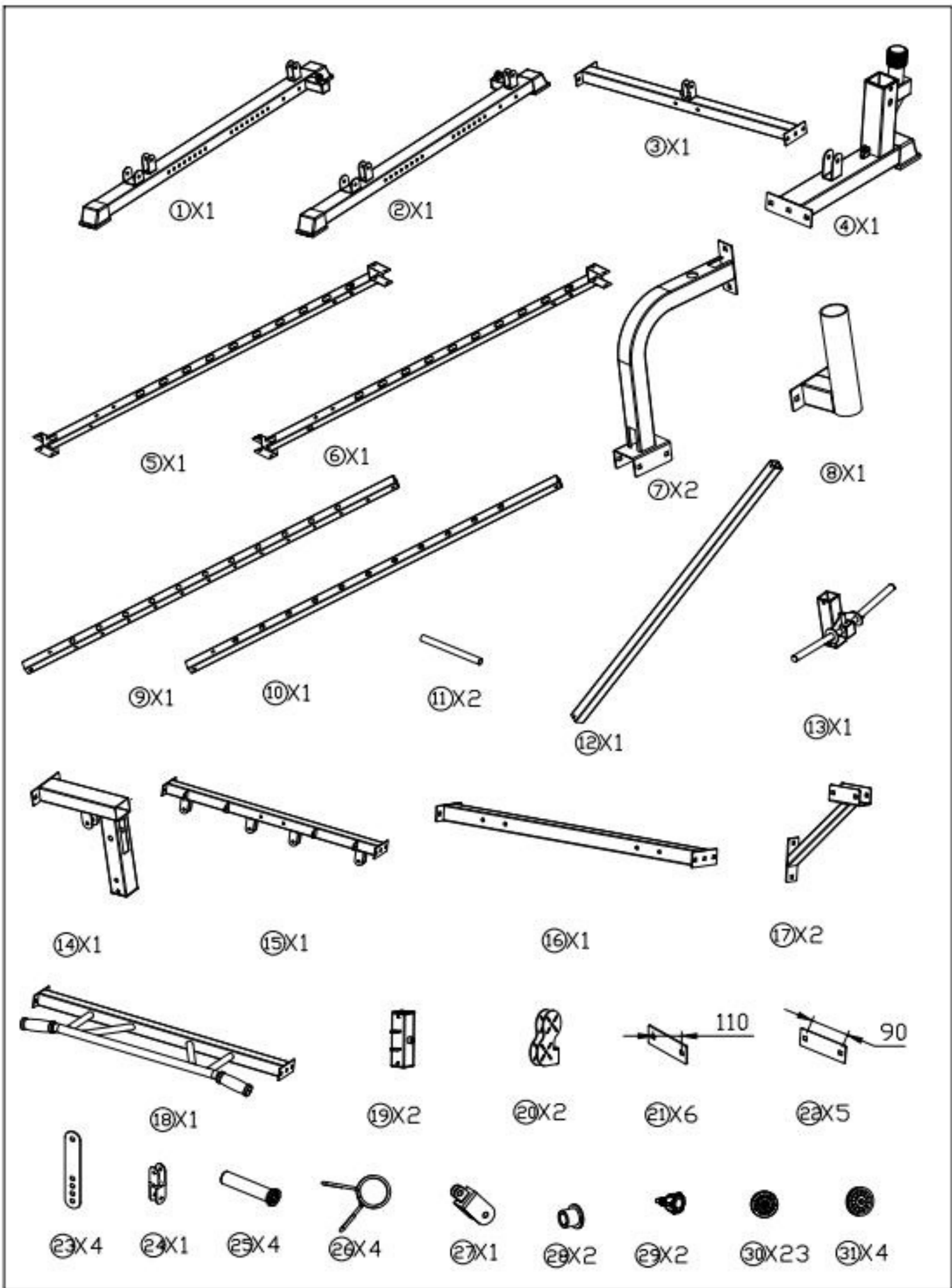

39

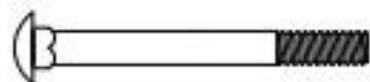

M10X90mm

4

38

 $\Phi 10$

4

37



M10

4

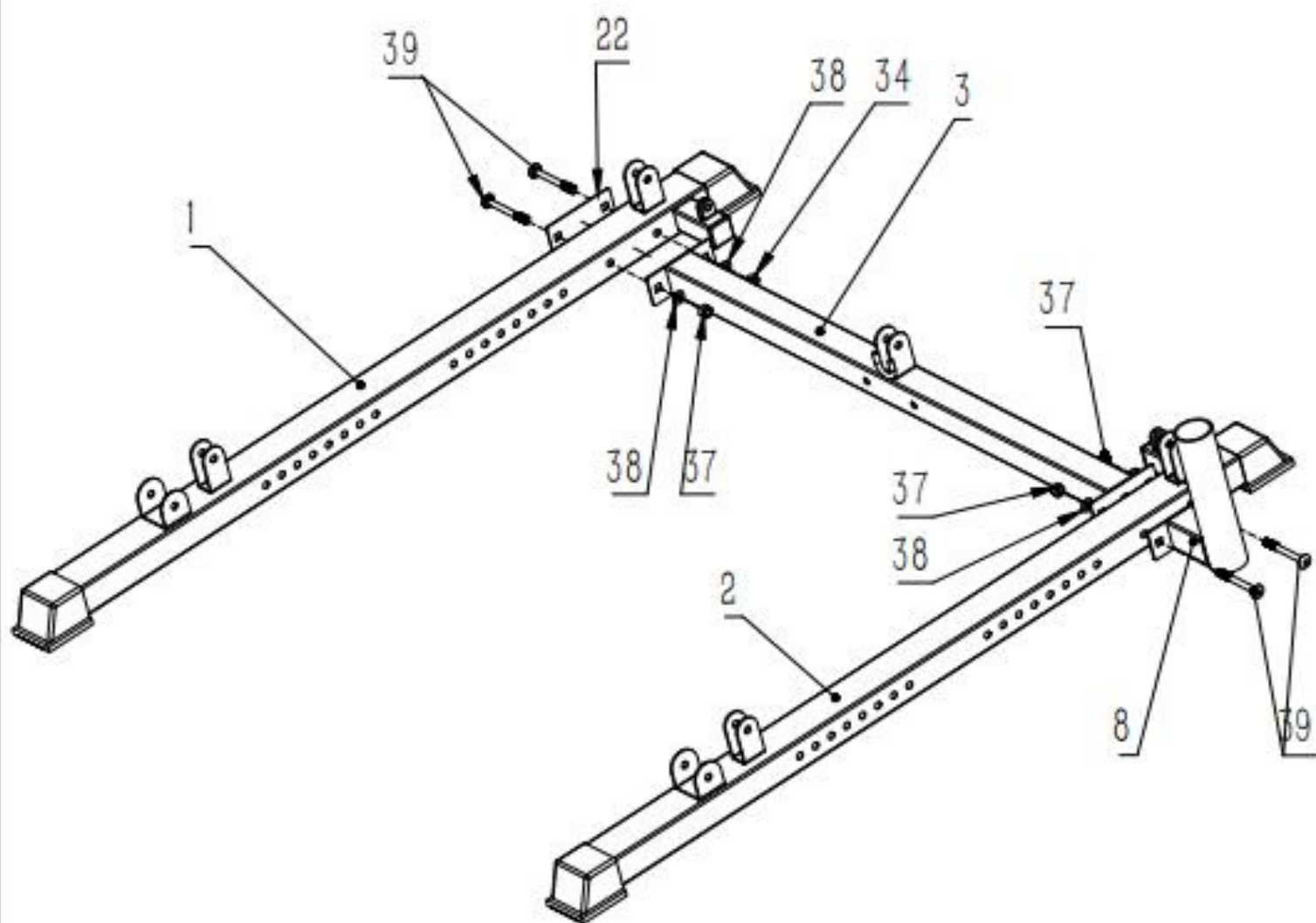

- 39
- 40
- 38
- 37
- 41

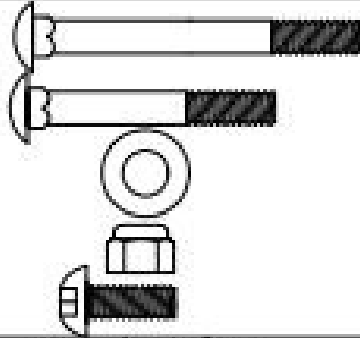

M10X90mm	4
M10X70mm	2
Φ10	8
M10	6
M10X20mm	2

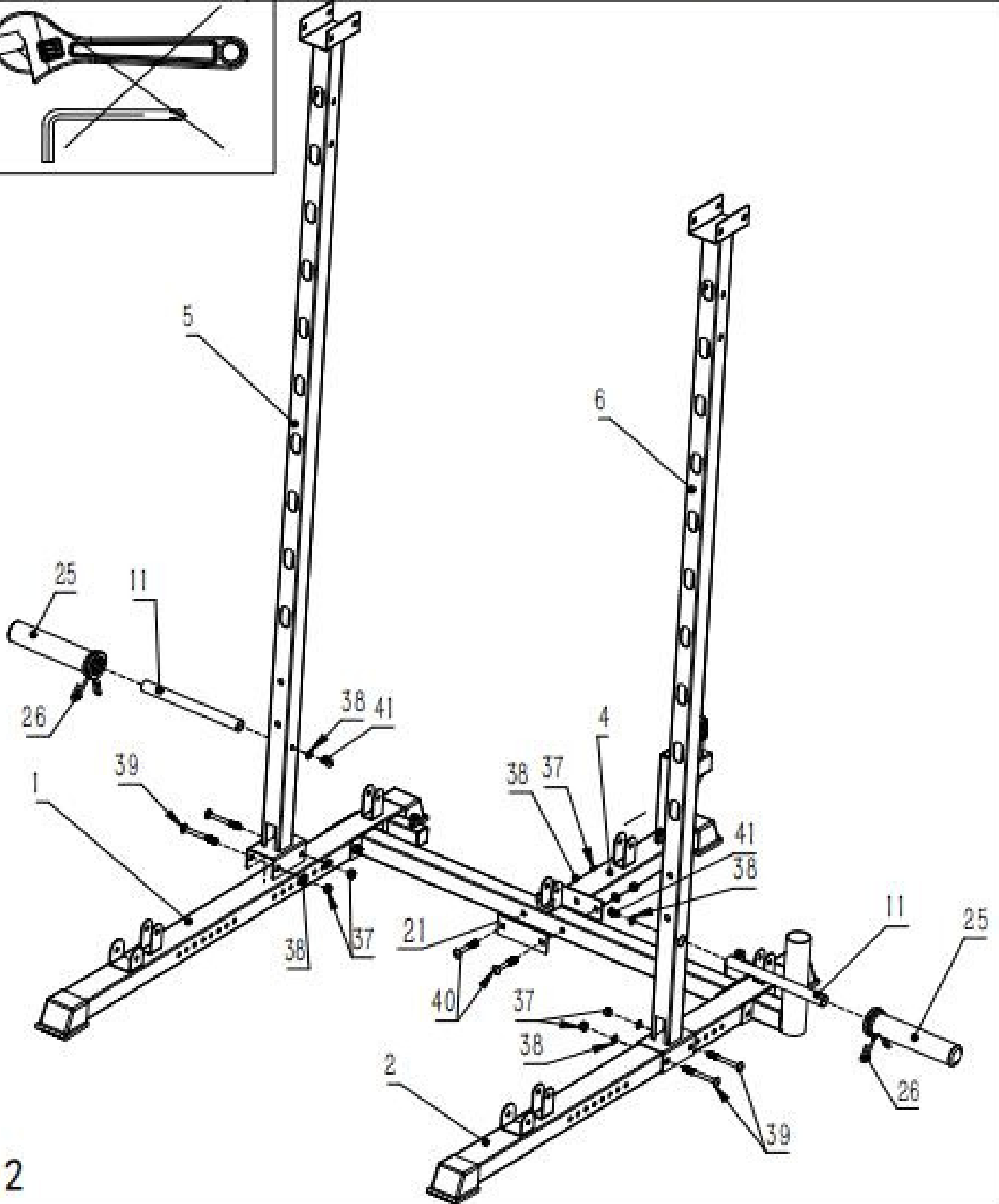
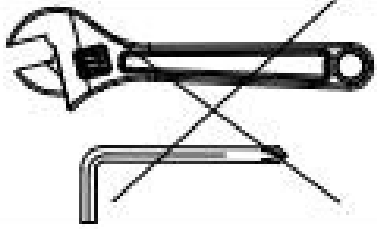

- 39
- 40
- 38
- 37

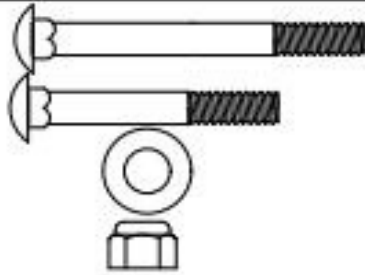

M10X90mm	4
M10X70mm	4
Φ10	8
M10	8

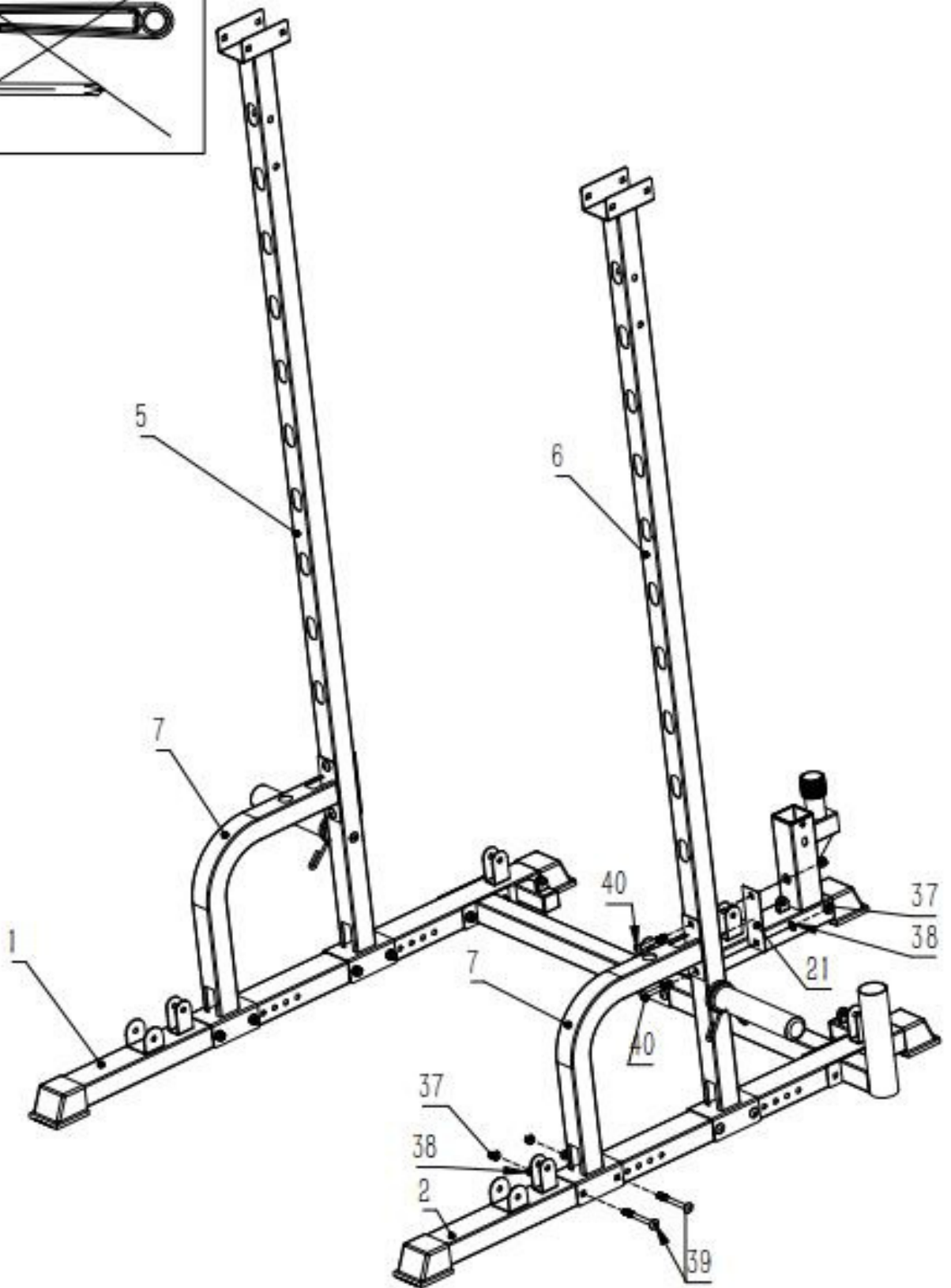
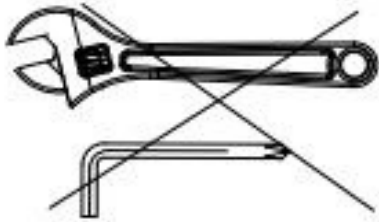

- 39
- 40
- 38
- 37

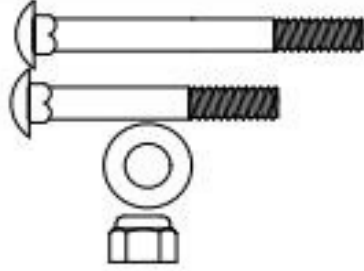

M10X90mm	4
M10X70mm	8
Φ10	12
M10	12

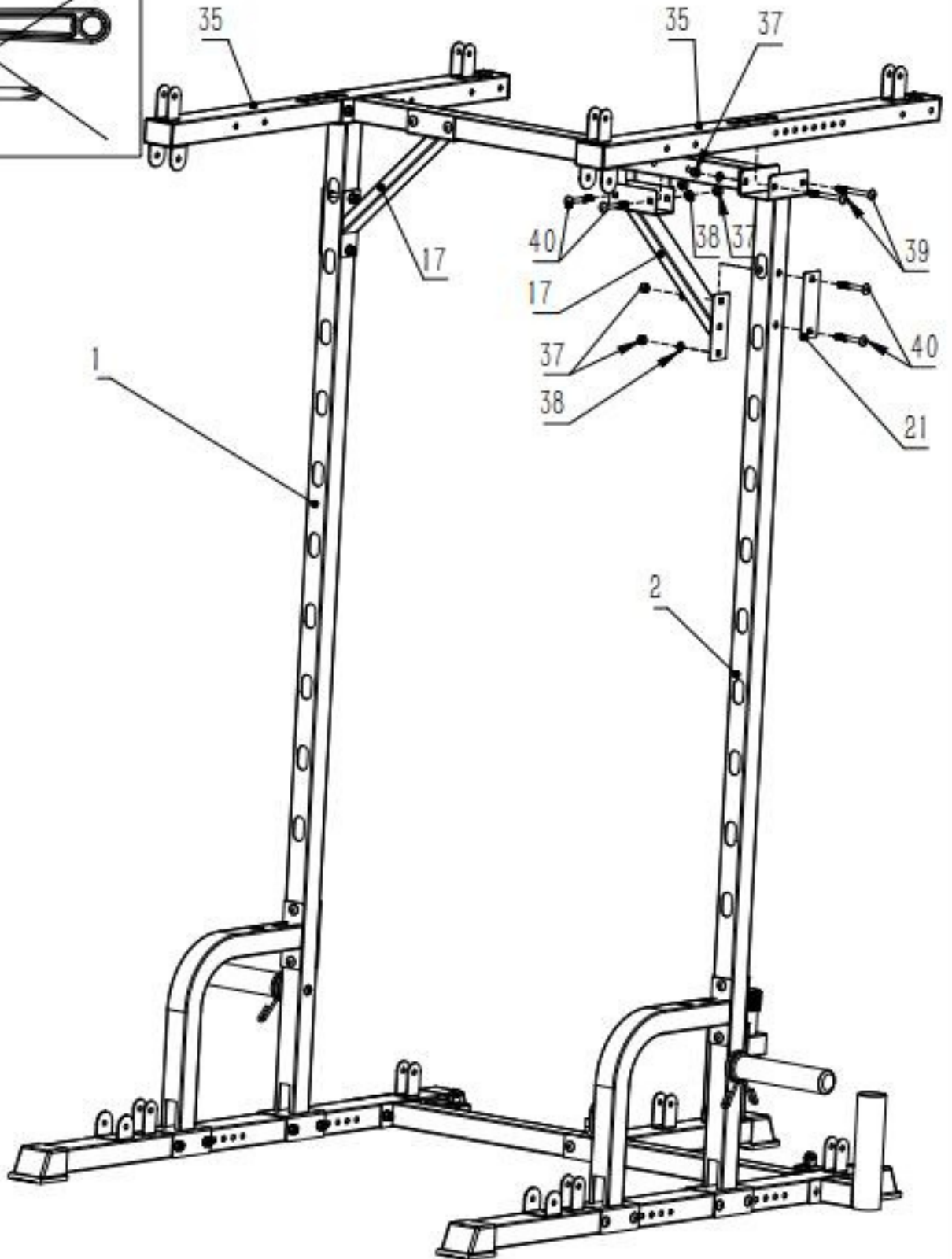
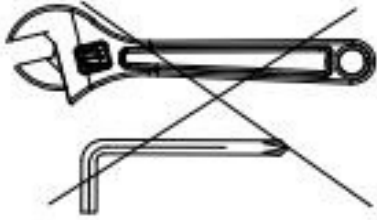

- 43
- 44
- 38
- 37

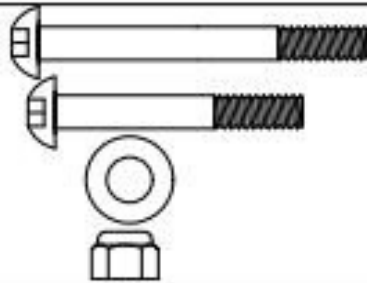

M10X90mm	2
M10X70mm	4
Φ10	12
M10	6

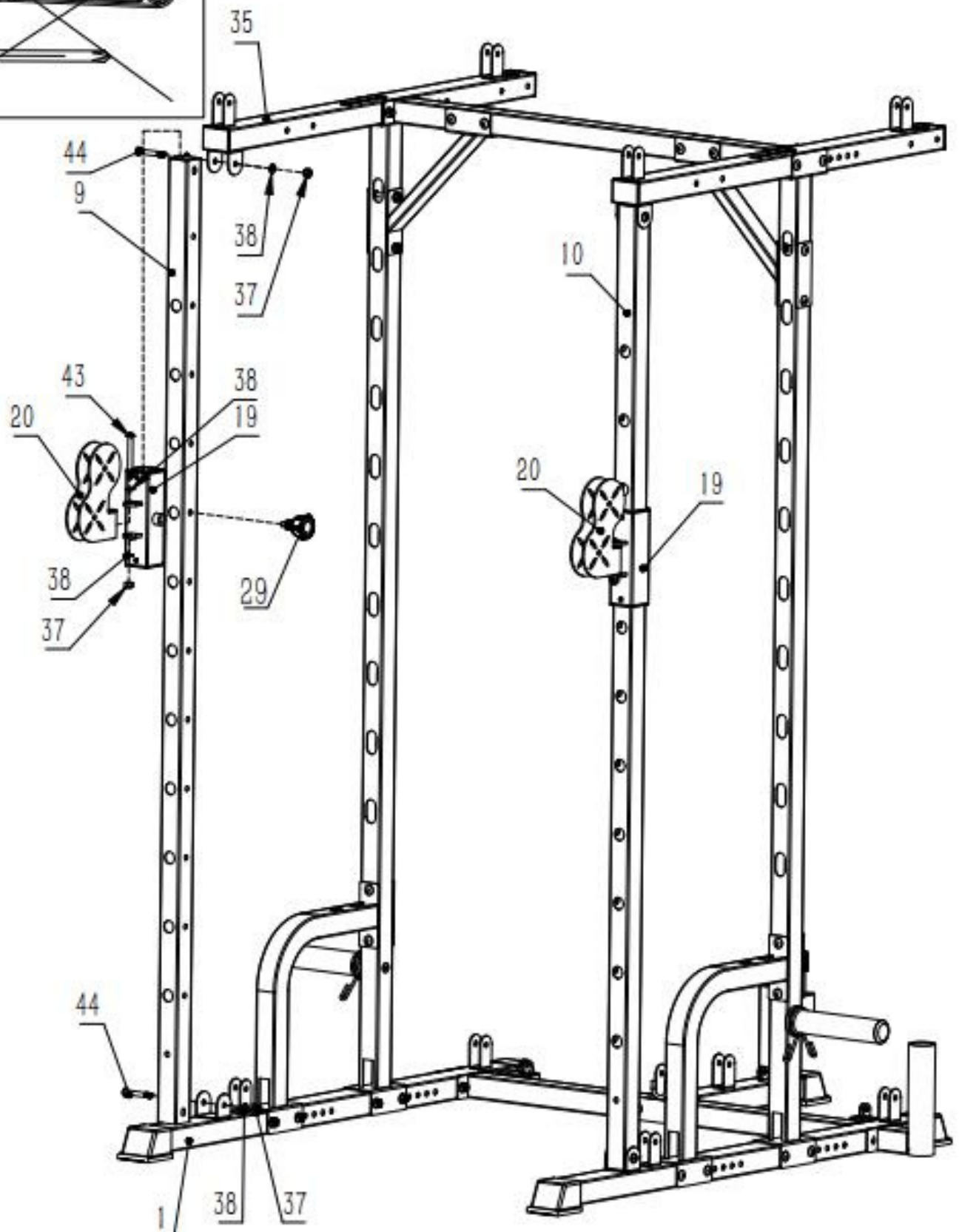

39
38
37

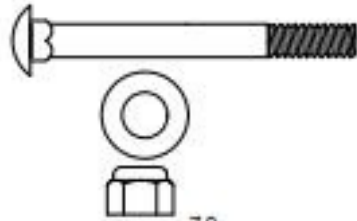

M10X90mm

8

Φ10

8

M10

8

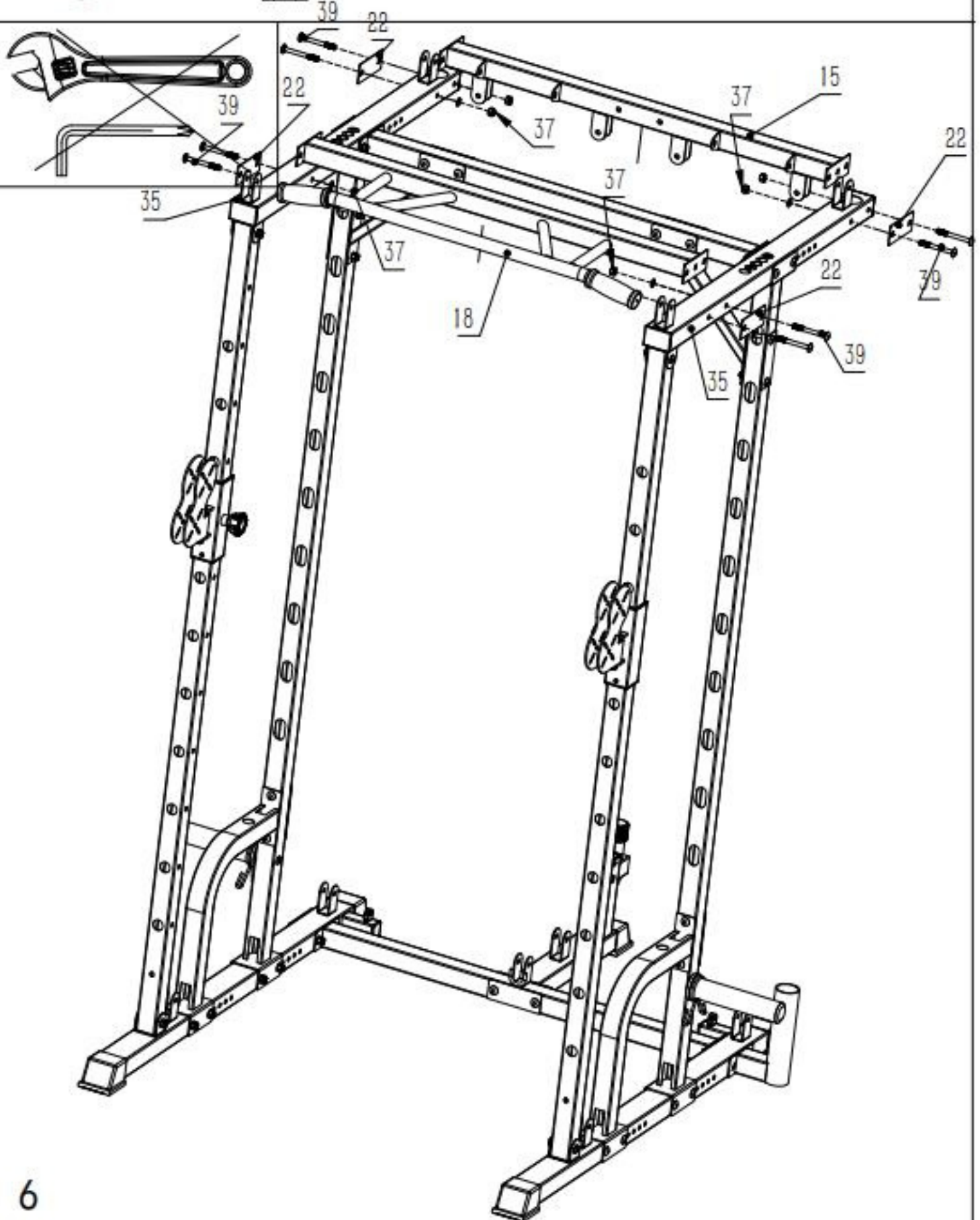

- 45
- 40
- 38
- 37

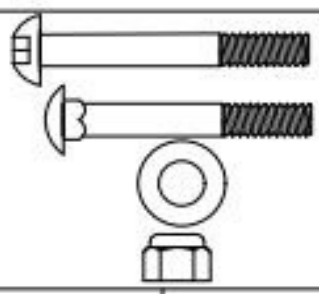

M10X75mm	2
M10X70mm	2
Φ 10	6
M10	4

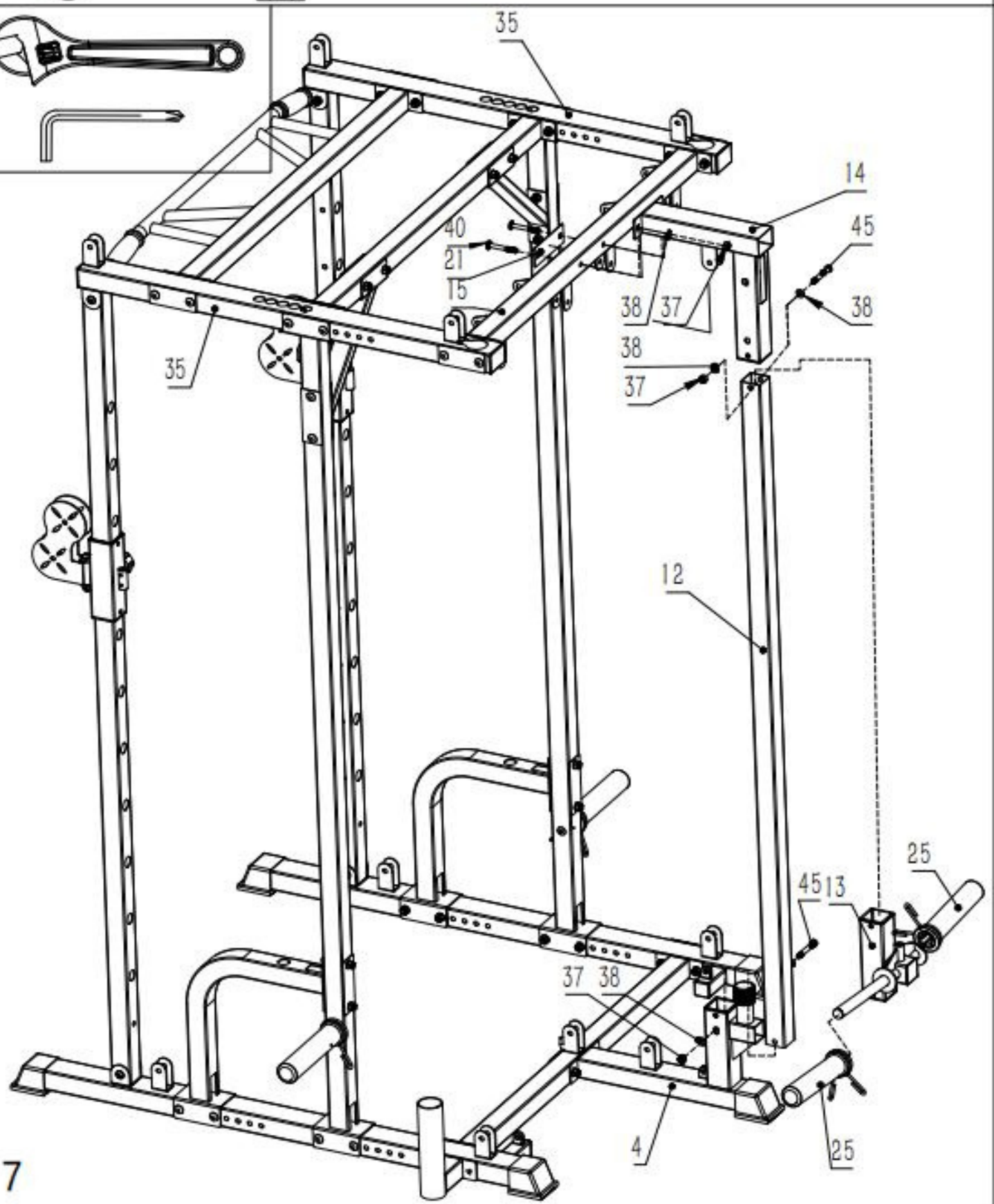

47



M10X45mm

11

46



M10X50mm

4

38



Φ10

30

37



M10

15

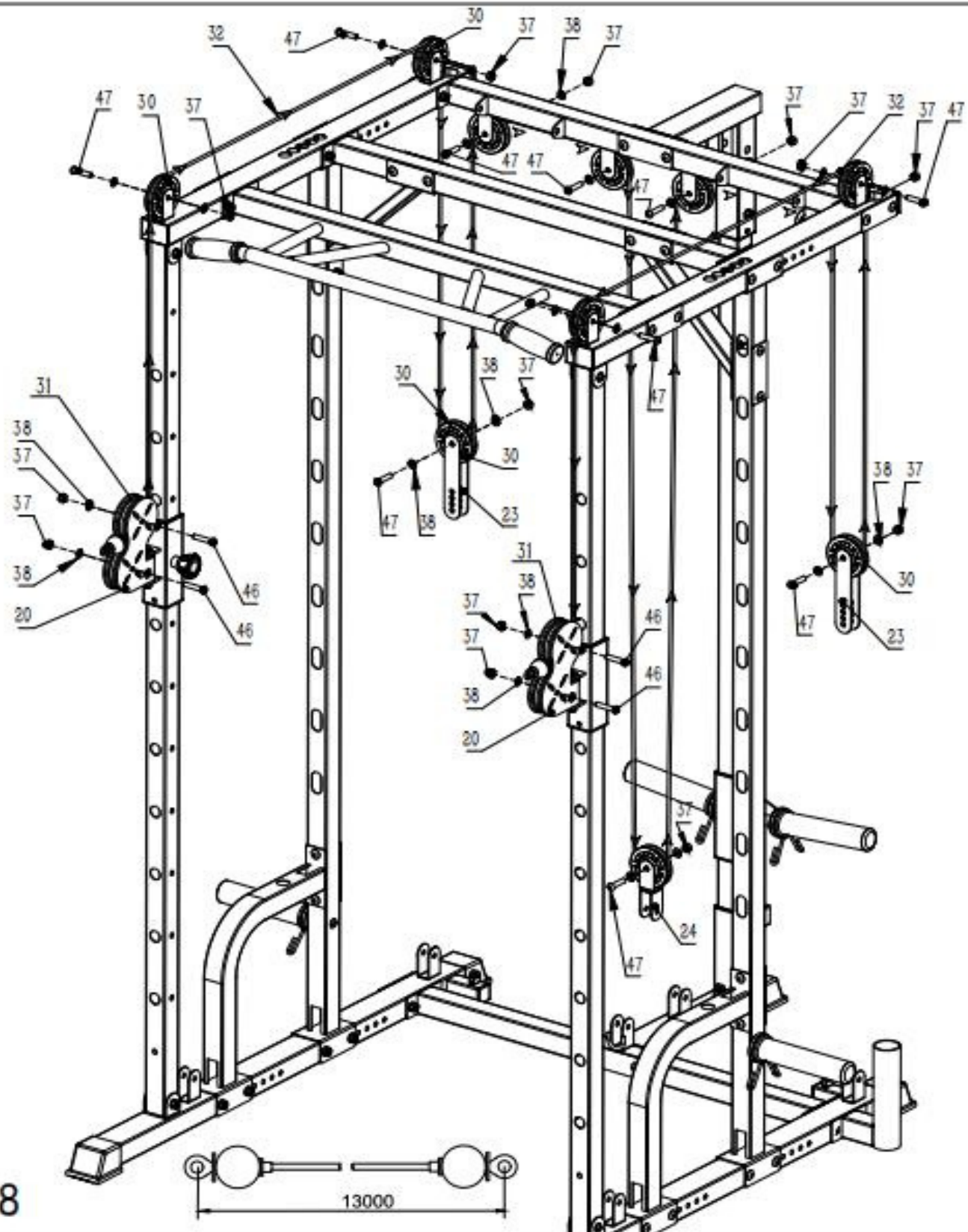

- 47
- 45
- 38
- 37
- 42

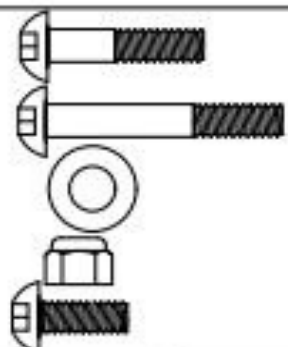

M10X45mm

1

M10X75mm

1

Φ 10

4

M10

3

M10X30mm

1

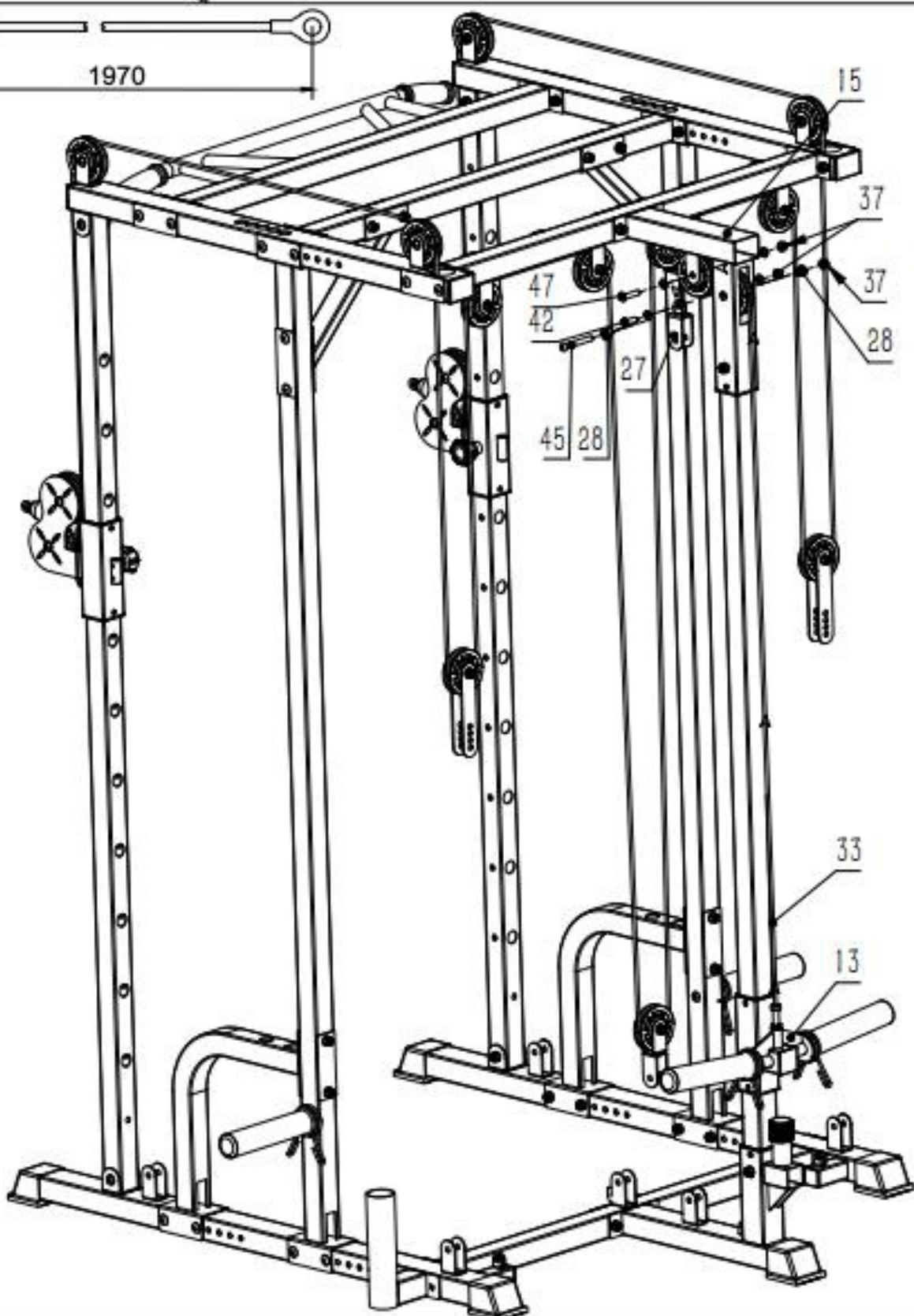
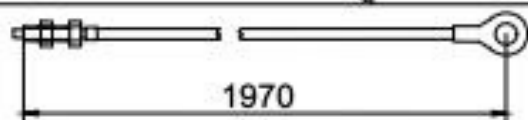

- 47
- 38
- 37
- 42

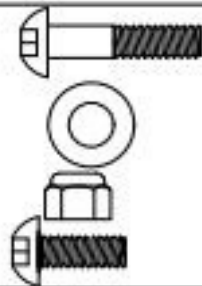

M10X45mm

4

Φ10

10

M10

5

M10X30mm

1

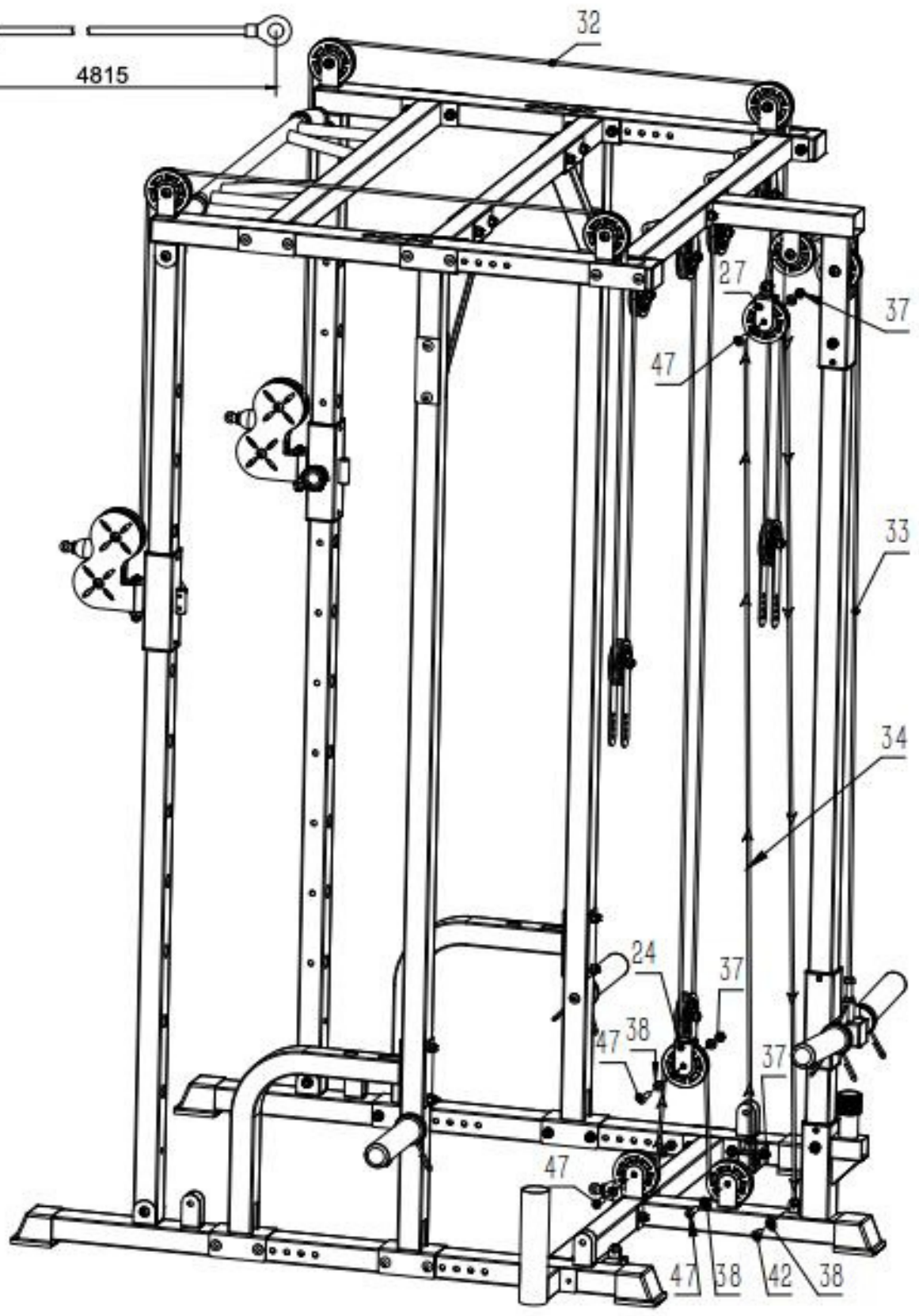
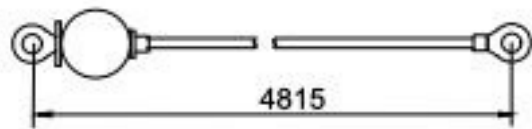

- 47
- 38
- 37
- 42

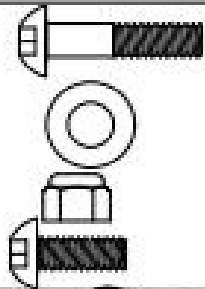

M10X45mm

3

Φ10

8

M10

4

M10X30mm

1

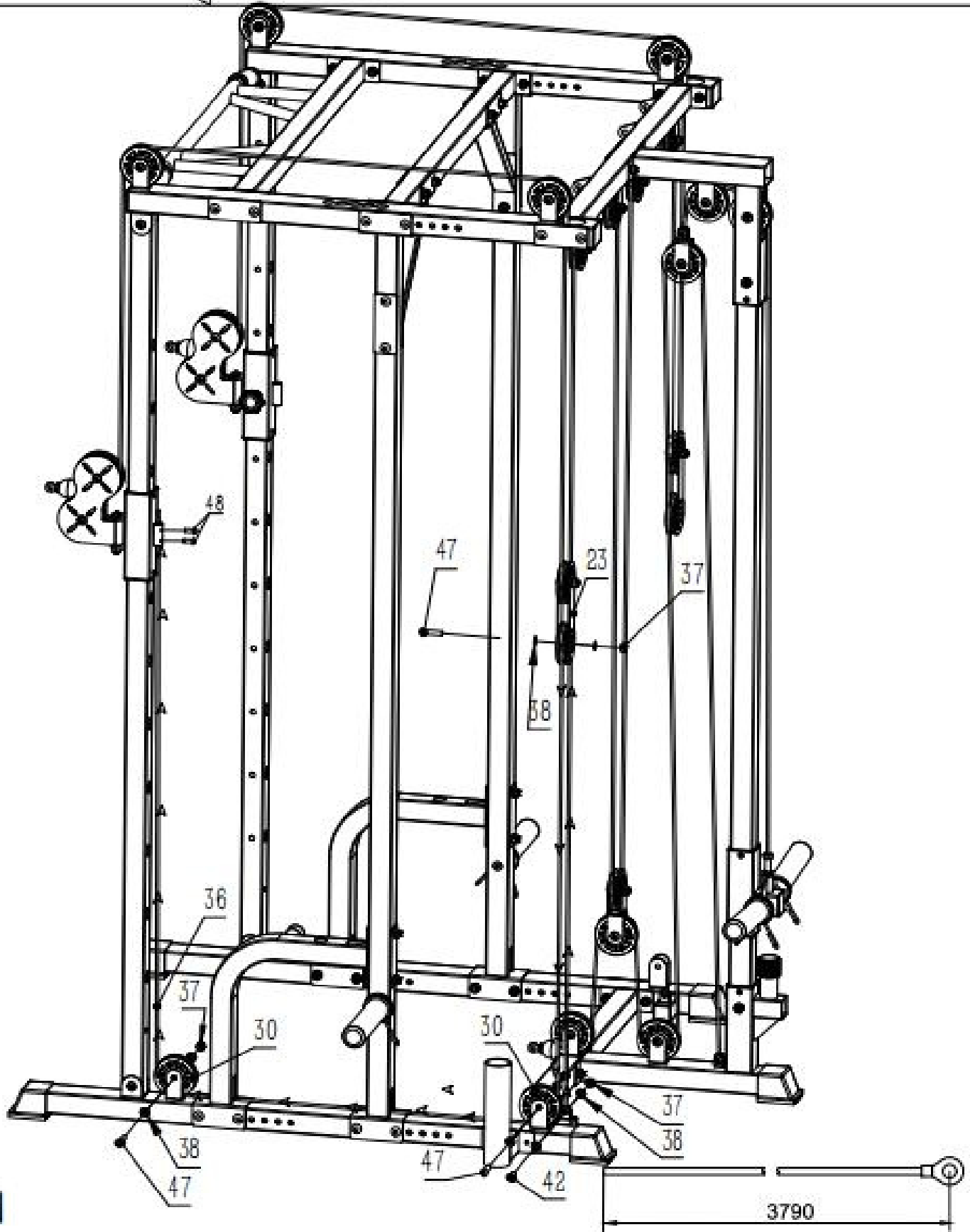

- 47
- 38
- 37
- 42

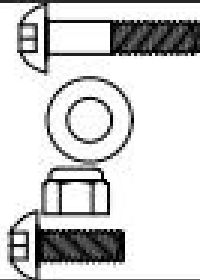

M10X45mm

3

Φ10

8

M10

4

M10X30mm

1

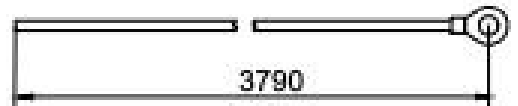
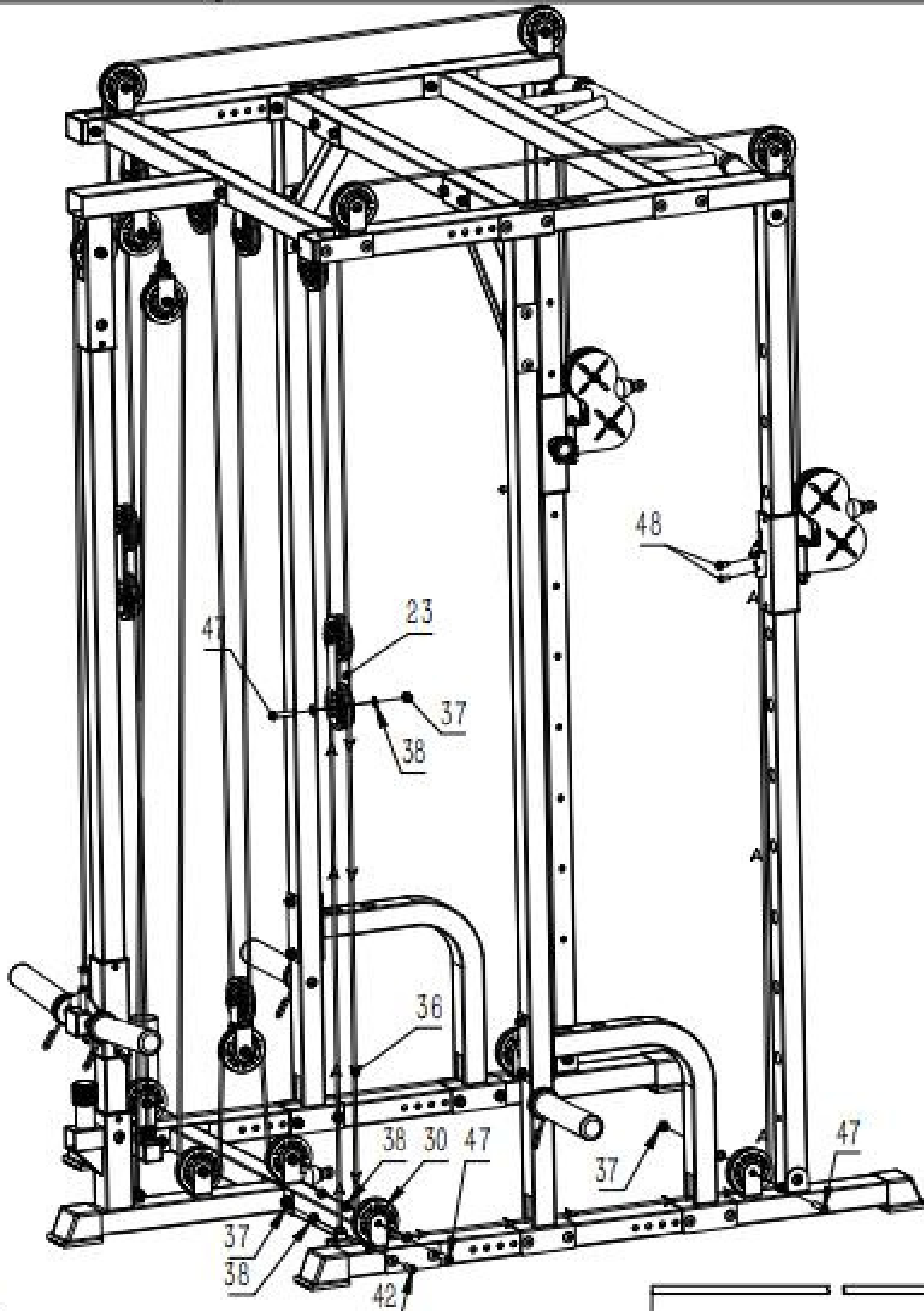

FICHA TÉCNICA DEL PRODUCTO



Peso máximo recomendado:

1. Barra Pull-ups: 200kg
2. Soporte de barra: 130kg
3. Barra tríceps: 120kg
4. Barra Smith: 110kg
5. Contrapeso poleas: 160kg
6. Barras almacenamiento: 150kg
7. Barras Rack: 130kg



FITNESS TECH