

Description: **ROBINHOOD 90CM ISLAND CANOPY RANGEHOOD WITH BLACK GLASS**
 Model Number: **RIJ3CL9BK**

Typical design

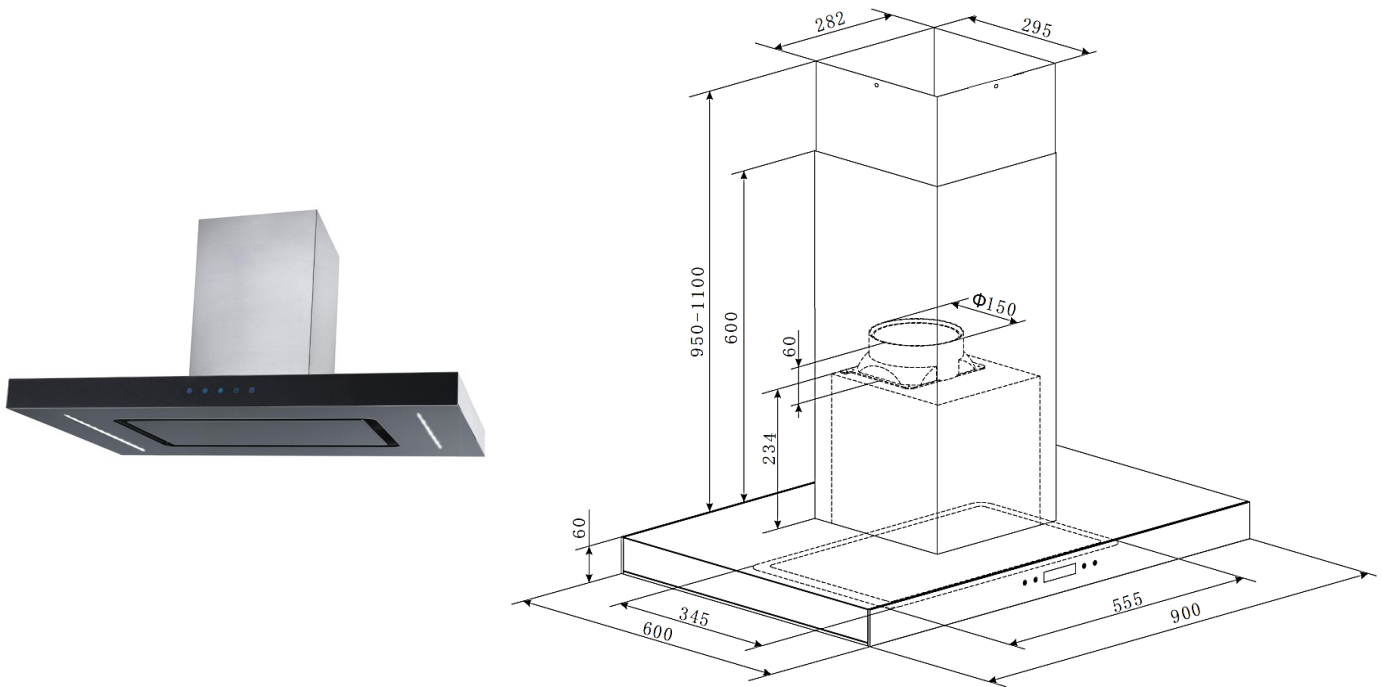

Features and benefits

- **High performance extraction fan**
 With a maximum motor performance of 1000 m³/hr, the powerful extraction fan rapidly removes steam, smoke and cooking smells from your kitchen. Three power levels let you select the fan strength you need.
- **LED lamps**
 2x 4W LED strip lights efficiently illuminate the entire cooking surface.
- **5-layered micromesh filters**
 5-layered aluminium filters effectively trap grease. They're simple to remove and are easily maintained with a regular clean in the dishwasher.
- **Touch Control**
 User-friendly touch control panel enables easy operation and it is also easy to clean.
- **Sleek design**
 The stainless steel body with black tempered glass front fascia delivers a sleek look; it's a perfect unit to fit over an island cooktop.
- **Fits multiple ceiling heights**
 With a maximum of 1100mm chimney height, this rangehood can fit ceiling height from standard 2.4m to 2.7m.
- **Ducting option**
 It can be ducted only.

Specifications

Technical data:

Motor type	3 speed centrifugal motor
Lights	2 x 4 Watt LED strips
Type of material	430 stainless steel + tempered glass
Type of control	Touch control
Power	265W, 220-240 Volt, 50 Hz
Electrical approval AS/NZS	60335.2.31:2004 + A1, A2, A3
EMC AS/NZS	CISPR14:2001
Performance tested to	IEC61591
Filter	5 layered micro mesh aluminium
Length of power cord	1500mm
Ducting outlet	150mm diameter round outlet – top ducting
Recirculation option	No, ducted only

Gross/Net weight: 40.0 kg/36.0 kg

Carton volume: 0.941m³

Carton dimensions : W960 x D455 x H665mm

Rangehood dimensions: W900 x D600 x H660-1160mm

Performance data:

IEC61591 Tested Results	Power Level	Airflow (m ³ /hr)	Noise Level (dB)
	1	452	54
	2	633	58
	3	797	60

New Zealand

Monaco Corporation Ltd
Telephone: (09) 415 6000
Facsimile: (09) 415 7400
Email: enquiries@robinhood.co.nz
www.robinhood.co.nz

Australia

Shiro Australia Pty Ltd
ABN 28 002 386 129
Telephone: 1800 648 556
Facsimile: 1800 628 577
Email: enquiries@robinhood.com.au
www.robinhood.com.au

