

Description: **ROBINHOOD SLASHBACK PREM LDRY**  
Model Number: **SB560B**

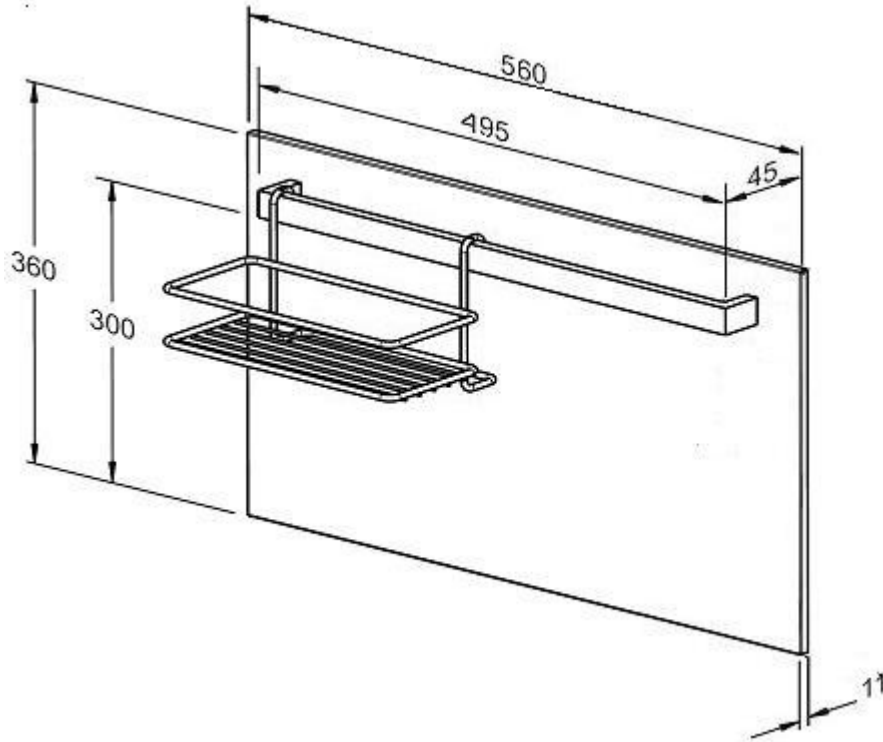

Model pictured: **SB560B**

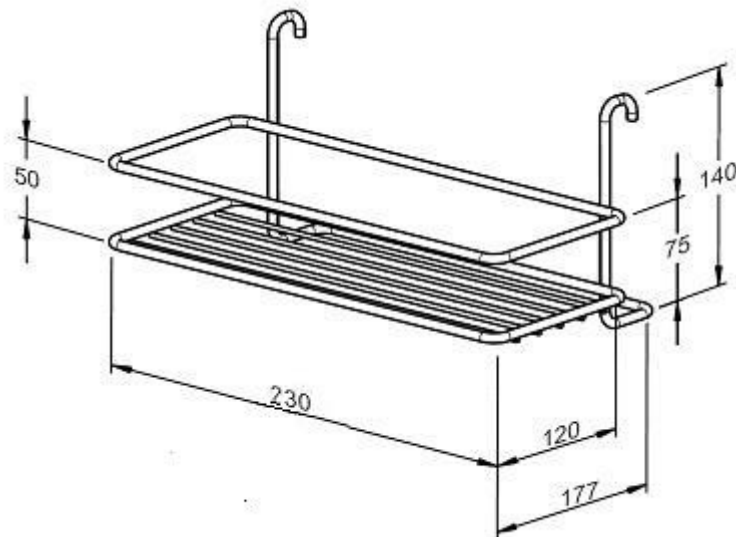

*All dimensions in mm  
Model may vary slightly from images pictured*

## Overview

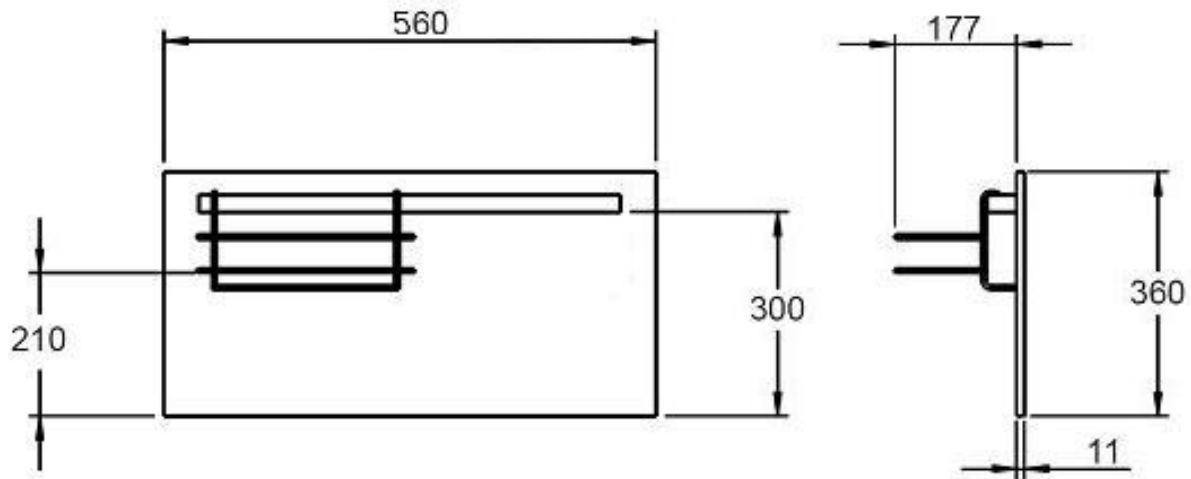

### Contents of packaging:

- 1 x Robinhood Splash Back
- 1 x Installation kit (incl screws, fixing washers, washers)
- 1 x Splash back handle
- 1 x Chrome baskets

## Pre-installation

### Important:

- Please read the entire instructions before installing the Splash back.

### Regulation compliance

Comply with current Drainage and Plumbing Regulations as required by your local authority. Sanitary plumbing shall only be carried out by a Registered Plumber. All plumbing work must be done in accordance with local and national building and plumbing codes as applicable. All electrical work must be done in accordance with local and national electrical codes as applicable. In some instances this product may need to be earthed.

### Determine site

Determine the most suitable position for the splash back. Mark the position on the wall as reference.

## Important safety information

- This Robinhood Splash back is not intended for use by young children or infirm persons without supervision.
- Young children should be supervised to ensure that they do not play with the Robinhood Supertub.
- Use abrasive household cleaner.

## Cleaning and maintenance

Powder coated surfaces must not be cleaned with abrasive or chemical cleaners. To keep the Robinhood Supertub looking its best, wipe regularly with a damp soft cloth. A mild soap and water solution may be used to remove stubborn dirt. Under no circumstances should harsh detergents (including chemical cleaners) such as bleach, scourers or any abrasive cleaner be used as these products may irreparably damage the surfaces of the Robinhood Supertub.

**NB. Their use will render the warranty void**

## Installing the Splash back

1. Fix handle using fixing screws and washers supplied.

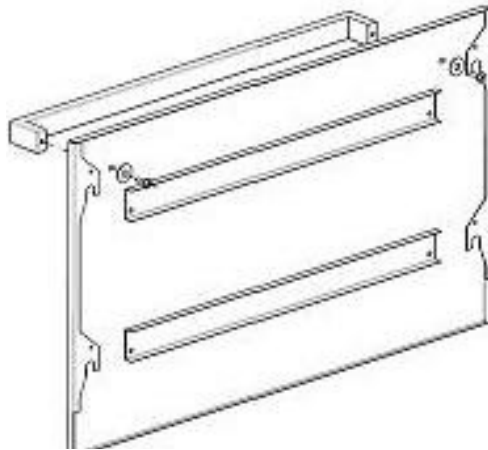

2. Fix mounting screws and cup washers to the wall using the dimensions given below. Mounting to a stud is recommended. However, if fitted to other wall linings (plasterboard, concrete etc) suitable wall fixings will be required (not supplied).

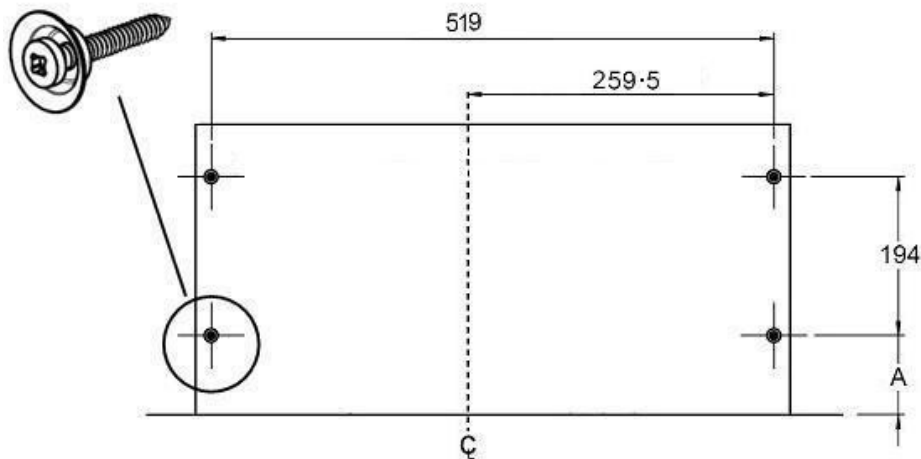

- A** Distance from the bench top to the lower fixing screw

**107mm** flush fit between the bottom surface of the splash back and the bench top

**110mm** allows a 3mm gap between the splash back and bench top if **sealing** is required

3. Hang splash back from the cup washers.
4. Seal the splash back to the wall using suitable approved sealant. (Check with your local council for building regulations).

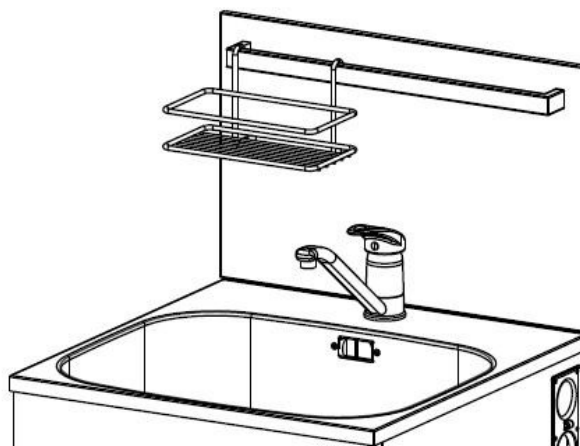

## Warranty Certificate (New Zealand)

### Terms and Conditions

The following conditions apply in respect of the warranty given in this certificate:

1. Parbury Pty Limited ("Parbury") warrants the following Robinhood products against manufacturing defects and faulty materials, under normal use and subject to the exclusions in this certificate, for a period of:  
**Uniduct** – 12 months from date of original purchase for domestic use.  
**Supertub** – 5 years on stainless bowl, 24 months on Tap, Cabinet and other components from the date of original purchase for domestic use.  
**Ironing centre** – 12 months from date of original purchase for domestic use.  
**Waste disposal** – 24 months from date of original purchase for domestic use.  
"Original purchase", when used in this certificate, means purchase by the customer directly from Parbury or one of its approved suppliers.
2. This warranty is limited to the repair or replacement, at our option, within the warranty period of any component part which we at our discretion determines to contain faulty materials or a manufacturing defect in breach of this warranty. This warranty is subject to terms and conditions set out in this certificate.
3. The warranty only applies within New Zealand.
4. The customer must produce the original invoice or other purchase documentation as proof of the original purchase date.

### Warranty exclusions

1. The warranty does not apply where, in Parbury's opinion:  
The defect is caused by misuse, wear and tear, dirt, fire or accidental damage.  
The product has been repaired or serviced by an unauthorised person.  
The product was not installed in accordance with our instructions.  
The product was purchased overseas or was not designed for use in New Zealand.  
The product was not used, cleaned or cared for in accordance with our instructions.  
The product was used outdoors.  
All Robinhood rangehoods are suitable for indoor use only, and not suitable over BBQs or charcoal cookers designed for outdoor use.
2. In addition, this warranty does not extend to damage or defects which in our opinion, directly or indirectly arise from or Exposing the product to acidic or corrosive materials or chemicals such as dyes, solvents, denture cleaner or acetone; Using inappropriate household cleaning products such as abrasive cream or powder cleansers, furniture polish, bleach, mentholated spirits, drain cleaners, sugar soap, metal pads and strongly alkaline or acidic cleaners; Heat damage, including from washing the product at high temperatures; Impact or mishandling the product, including the impact caused by objects scraped along, thrown or dropped on the surface or excessive weight being placed on the product; Structural or support changes in or affecting the building or the application where the product has been installed; Failure to clean or maintain the product as recommended; or Any other causes specified in the product information as being excluded from this warranty.
3. Variations with the colour or gloss within the product or any ageing or fading of colour, shine or gloss level over time are not covered by this warranty. The warranty does not cover visual imperfections or blemishes in the surface and edges of product that were not brought to your supplier's attention at the time you inspected the product.
4. Costs incurred on installation or removal of a product, or any reinstallation of a product, or any associated costs, are not covered by this warranty.
5. Parbury will not be liable for consequential or indirect loss or damage whatsoever and however arising out of or in with the supply, performance or removal of the product, including (but not limited to) loss of profit, loss of revenue, loss of contract, loss of goodwill or increased cost of workings, even if due to the negligence of Parbury or any of its approved suppliers, employees or agents.
6. Charcoal filters and light bulbs are not covered by this warranty
7. This warranty and the statements contained in this certificate or other documents given to you do not exclude, restrict or modify the application of any term implied into this warranty by statute, provided that (to the extent any statutory permits Parbury to limit its liability for a breach of an implied condition or warranty) Parbury's liability for such breach is to the payment of the cost of replacing the product, repairing the product or acquiring an equivalent product.
8. Subject to clause 5, our obligations under this warranty are limited to those set out in this certificate, and this warranty is expressly instead of all other warranties, express or implied, including any implied warranty of merchantability or fitness particular purpose and notwithstanding any course of dealing between the parties or custom and usage in trade to the contrary.

Should warranty service be required, please contact us:

Free Phone: 1800 648 556

Free Fax: 1800 628 577

Email: [enquiries@robinhood.co.nz](mailto:enquiries@robinhood.co.nz)

Website: [www.robinhood.co.nz](http://www.robinhood.co.nz)

Terms and conditions are subject to change without notice

## Warranty Certificate (Australia)

### Terms and Conditions

The following conditions apply in respect of the warranty given in this certificate:

1. Parbury Pty Limited ("Parbury") warrants the following Robinhood products against manufacturing defects and faulty materials, under normal use and subject to the exclusions in this certificate, for a period of:  
**Rangehood** - 24 months from date of original purchase for domestic use.  
**Supertub** - 5 years on stainless bowl, 24 months on Tap, Cabinet and other components from the date of original purchase for domestic use.  
**Uniduct** - 12 months from date of original purchase for domestic use.  
**Ironing centre** - 12 months from date of original purchase for domestic use.  
"Original purchase", when used in this certificate, means purchase by the customer directly from Parbury or one of its approved suppliers.
2. This warranty is limited to the repair or replacement, at our option, within the warranty period of any component part which we at our discretion determines to contain faulty materials or a manufacturing defect in breach of this warranty. This warranty is subject to terms and conditions set out in this certificate.
3. The warranty only applies within the Commonwealth of Australia.
4. The customer must produce the original invoice or other purchase documentation as proof of the original purchase date.

### Warranty exclusions

1. The warranty does not apply where, in Parbury's opinion:  
The defect is caused by misuse, wear and tear, dirt, fire or accidental damage.  
The product has been repaired or serviced by an unauthorised person.  
The product was not installed in accordance with our instructions.  
The product was purchased overseas or was not designed for use in Australia.  
The product was not used, cleaned or cared for in accordance with our instructions.  
The product was used outdoors.  
All Robinhood rangehoods are suitable for indoor use only, and not suitable over BBQs or charcoal cookers designed for outdoor use.
2. In addition, this warranty does not extend to damage or defects which in our opinion, directly or indirectly arise from or are due to:  
Exposing the product to acidic or corrosive materials or chemicals such as dyes, solvents, denture cleaner or acetone;  
Using inappropriate household cleaning products such as abrasive cream or powder cleansers, furniture polish, bleach, mentholated spirits, drain cleaners, sugar soap, metal pads and strongly alkaline or acidic cleaners;  
Heat damage, including from washing the product at high temperatures;  
Impact or mishandling the product, including the impact caused by objects scraped along, thrown or dropped on the product surface or excessive weight being placed on the product;  
Structural or support changes in or affecting the building or the application where the product has been installed;  
Failure to clean or maintain the product as recommended; or  
Any other causes specified in the product information as being excluded from this warranty.
3. Variations with the colour or gloss within the product or any ageing or fading of colour, shine or gloss level over time are not covered by this warranty. The warranty does not cover visual imperfections or blemishes in the surface and edges of the product that were not brought to your supplier's attention at the time you inspected the product.
4. Costs incurred on installation or removal of a product, or any reinstallation of a product, or any associated costs, are not covered by this warranty.
5. Parbury will not be liable for consequential or indirect loss or damage whatsoever and however arising out of or in connection with the supply, performance or removal of the product, including (but not limited to) loss of profit, loss of revenue, loss of contract, loss of goodwill or increased cost of workings, even if due to the negligence of Parbury or any of its approved suppliers, employees or agents.
6. Charcoal filters and light bulbs are not covered by this warranty
7. This warranty and the statements contained in this certificate or other documents given to you do not exclude, restrict or modify the application of any term implied into this warranty by statute, provided that (to the extent any statutory provision permits Parbury to limit its liability for a breach of an implied condition or warranty) our liability for such breach is limited to the payment of the cost of replacing the product, repairing the product or acquiring an equivalent product.
8. Subject to clause 5, our obligations under this warranty are limited to those set out in this certificate, and this warranty is expressly instead of all other warranties, express or implied, including any implied warranty of merchantability or fitness for a particular purpose and notwithstanding any course of dealing between the parties or custom and usage in trade to the contrary.

Should warranty service be required, please contact us:

Free Phone: 1800 648 556

Free Fax: 1800 628 577

Email: [enquiries@robinhood.com.au](mailto:enquiries@robinhood.com.au)

Website: [www.robinhood.com.au](http://www.robinhood.com.au)

Terms and conditions are subject to change without notice