

Description: **ROBINHOOD WASTE DISPOSAL- SCRAPEATER**
Model Number: SE390, SE390Q, SE390QA, SE520Q & SE520QA

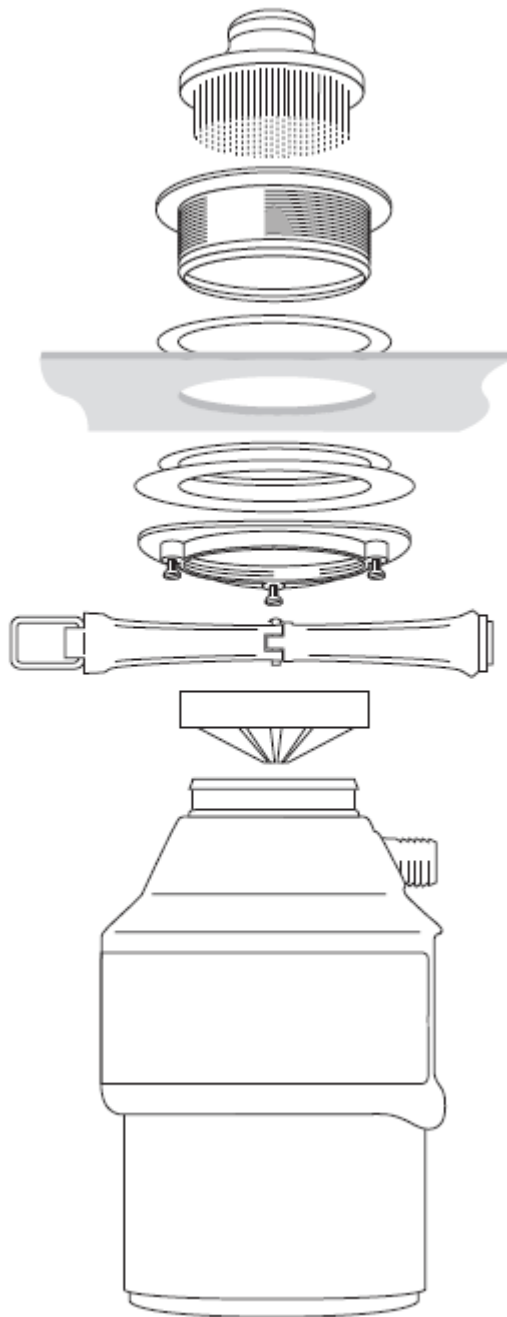

Model may vary slightly from image pictured

Overview

Contents of packaging:

1. Plug with brush
(spare gasket supplied in bag)
2. Stainless Steel Sink Flange
3. Rubber gasket
4. Fibre gasket
5. Stainless Steel Mounting ring
6. Hinged clamp
7. Splash baffle
8. Rubber gasket
9. Waste pipe (2 x screws)
10. Wrench
11. Main body

Air Switch option not shown.
Air switch and plastic tubing not shown.

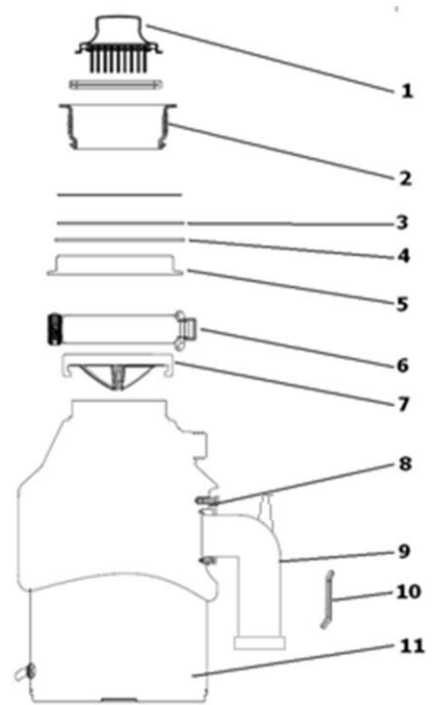

Pre-installation

Important:

Before you start to install your Robinhood Waste disposal please read through the entire instruction manual thoroughly. The set of instructions provided is general: local building codes take precedence over the instructions in this guide and your installation must conform to the building codes in your area. Be sure to retain this set of instructions for future reference.

Typical equipment required:

1. Philips and flat blade screwdrivers
2. Hammer
3. Channel lock pliers, slip joint
4. Screwdriver
5. Adjustable pipe wrench

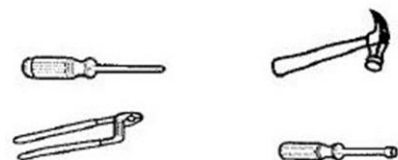

Materials & Accessories

1. Petroleum jelly, liquid soap or cooking oil
2. Hose clamp (optional)
3. Dishwasher drain connector (optional)
4. Plumbers Tape

Securing the Sink flange

Before installing your waste disposal makes sure you have all the components necessary, by checking through the component list above. Disassemble all the components and separate the sink flange assembly, excluding the splash baffle, from the main waste disposal body.

1. First, unhook the hinged clamp that holds the sink flange and the main body together.
2. Once the clamp is unhooked pull on the flange to detach it from the main body.
3. Then unscrew the mounting ring from the sink flange. Upon doing this the two gaskets should fall out as well.

To ease the installation process, make sure to leave the rubber splash baffle attached onto the main body.

1. When installing the unit, place the rubber gasket over the sink flange's threaded ring. Insert the flange and rubber gasket into the sink drain opening from the top side of the sink. (It is not necessary to use plumber's putty when installing the sink flange).
2. Insert the fibre gasket and Rubber gasket from the underside of the sink.
3. Attach the mounting ring and tighten with one hand while using the other hand to press down on the sink flange. Hand tighten as tight as possible. Do not try to tighten with a wrench or hammer. Now tighten the screws in the mounting ring to lock it in place.

NOTE; Failure to use all supplied gaskets and seals or to mount the unit straight may mean that the unit does not fasten tightly to the sink. Incorrect Installation may result in the unit leaking, and is not covered by warranty.

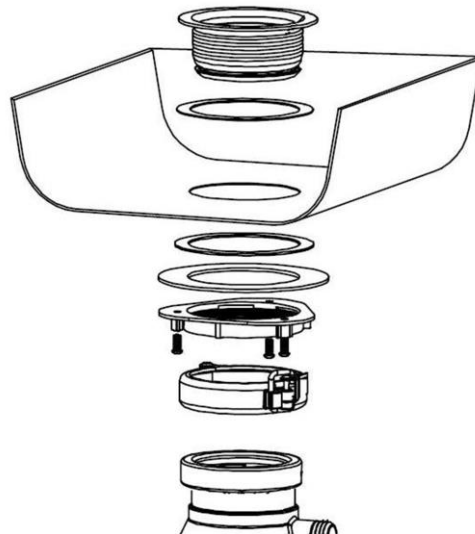

Dishwasher Connection (Optional)

If you plan on connecting your dishwasher drain pipe to your waste disposal, remove the plug in the dishwasher drain connection opening with the help of a screwdriver and a rubber mallet. Remove the plastic plug from the inside of the disposer by holding the disposer upside down and allowing the plastic plug to fall out. Ensure all parts are removed.

The dishwasher drain outlet on your Robinhood waste disposal will accept a 22mm drain hose. Fasten the connection tube in place with a hose clamp.



Mounting the Disposer

1. The rubber splash baffle should be attached to the main body of the waste disposal and not the sink flange. Using two hands push the main body upwards so that the inner groove of the splash baffle locks onto the sink flange. If necessary use cooking oil or similar products to lubricate the inner rim on the exposed side of the splash baffle. Once engaged the disposer will hang freely by itself.
2. Align unit so the waste outlet is able to be connected to the house plumbing.
3. Place the hinged clamp around the splash baffle and lock in place.

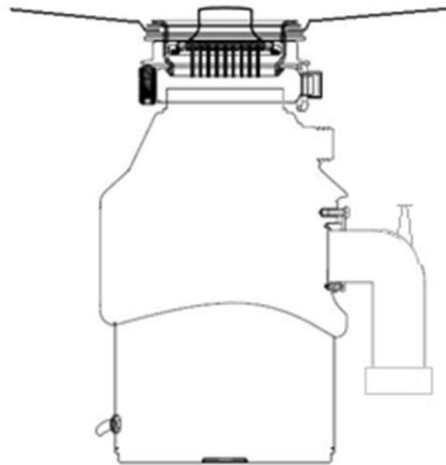

4. The appliance must be installed so that the reset button located under the unit is readily accessible.

NOTE; Failure to use all supplied gaskets and seals or to mount the unit straight may mean that the unit does not fasten tightly to the sink. Incorrect Installation may result in the unit leaking, and is not covered by warranty

Plumbing Connection

1. Check inside the disposer to make sure that no foreign objects are inside the grinding hopper.
2. The Rubber gasket should come already attached to the waste pipe. If not, attach the rubber gasket to the waste pipe so that the circular ridge on the rubber gasket is facing the main body of the unit, and the flat side of the rubber gasket faces the waste pipe. **THIS MUST BE DONE BEFORE INSERTING WASTE PIPE OR MAY CAUSE THE UNIT TO LEAK.**
3. Use the screws to tighten the waste pipe to the disposer. (NB: Do not over tighten). Tighten the two side screws evenly using the hex key provided.
4. Connect the pipe to the waste drain line. (NB: U-trap or P-trap should be used, rather than a ball ball trap). Plumbers tape is recommended to ensure a proper seal.
5. If fitted to a double sink, the use of separate traps for the disposer and the sink is recommended.
6. Make sure the hinged clamp is locked firmly in place.

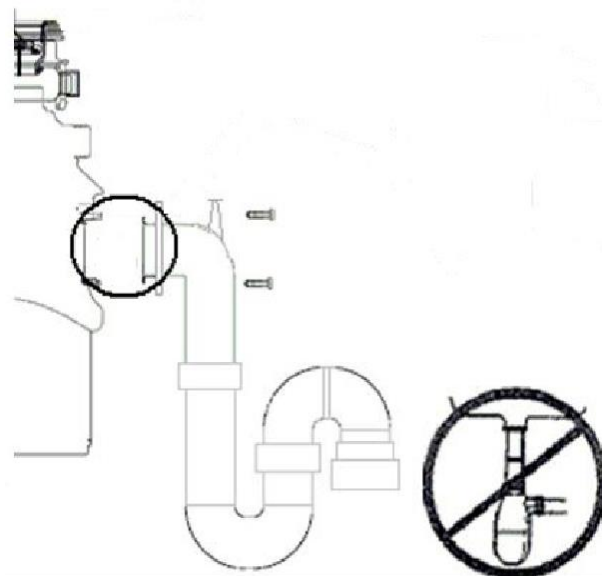

SAFETY NOTE; THE GRINDING TURNTABLES ARE EXPOSED UNTIL THE WASTE PIPE IS ATTACHED. PLEASE DO NOT POWER UP THE UNIT UNTIL PIPES ARE CONNECTED.

Air Switch Option (SE390QA & SE520QA models only)

1. To install the push button air switch proceed as follows:
2. Drill a 35 mm wide hole in the kitchen work top or corner of the sink at the most convenient point for use.
3. Unscrew the mounting ring of the air switch. Remove fibre washer. Insert the air switch through the hole.
4. Position fibre washer on the thread of the switch, then tighten the locking ring until the washer is held firmly against underside of the worktop or sink.
5. Unscrew the black hexagon adapter on the underside of the air switch
6. Insert one end of clear tube through the adapter and then over the male connector of the switch and tighten the two together.
7. Insert the other end of clear tube through the adapter and then over the male connector on the underside of the waste disposal and tighten the two together.
8. Push button to test waste disposal.

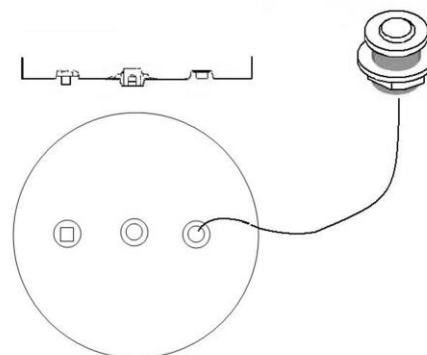

Your food waste disposal unit is now ready to use.

NOTE IF YOU CHOOSE NOT TO INSTALL YOUR AIR SWITCH The Factory setting for Air Switch Models is the ON position. If your unit fails to start after installation it may be set to the OFF position. TO set to ON, attached the Air Switch and the press once to reset to ON. You can then detach the Air Switch from the unit if not required.

Testing

Once you have successfully connected your waste disposal, it is ready for use. However, it is still necessary to ensure all your connections are secure.

! A test run must be carried out to identify any immediate faulty connections or leaks.

1. First, turn on the cold water to a medium-high flow, allowing the water to flow through the waste disposer.
2. Check to see if there are leaks in the plumbing connections or waste disposer.
3. Now, turn on the waste disposer and recheck all connections for leaks or loose joints.
4. If at this point you see no leaks or loose joints, your waste disposer is safe for use.
5. Turn off your waste disposer first and then the water supply.

Operating instructions

1. Remove the sink drain plug.
2. Turn on the cold water to a medium-high flow, allowing the water to flow into the waste disposer.
3. Turn on the waste disposer (Air switch if provided).
4. Put all the food waste into the disposer while the disposer is operating and the water is running. Use the extrusion attached to the drain plug to push the food down the disposer. Do not put your hand into the disposer.
5. Cut or break up large bones, rinds and cobs in order to speed up the waste disposal process. The disposer may slow down while grinding in order to increase torque (grinding power) which is part of normal operating conditions.
6. Let the disposer continue to run for about half a minute after the grinding has stopped.
7. Turn off your disposer (Air switch if provided).
8. Turn off the water once the impellers have stopped spinning.

RESETTING YOUR WASTE DISPOSAL UNIT

Your disposer is equipped with an overload protector which prevents the disposer from running should it overload. **Overload generally occurs when a foreign object has fallen into the disposer and jammed the impellers, thus preventing the motor from turning.** Overload may also occur if you have put too much food waste into the disposer at a time. If overload occurs, turn off the disposer and remove the foreign matter or food waste from the disposer. Insert the 8mm hex wrench supplied, into the opening at the bottom of the motor shaft and **rotate the tool clockwise and then anti clockwise until the wrench turns freely.** Wait five minutes before pushing the red reset button on the bottom of the disposer. Then run water through the unit, switch it on and check for normal operation. If the unit is still block repeat this process

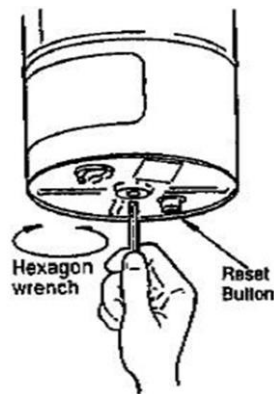

With normal usage your disposal should not require any special care.

1. The motor is permanently lubricated and should not require oiling under normal usage conditions.
2. If used according to the operating instructions above, your disposer should not require cleaning. However, should it start to smell, grinding a tray of ice cubes in the disposer will help clean all the inner components. Grinding a lemon, cut into quarters, will also give your disposer a fresh, clean smell.
3. Mineral deposits resulting from stagnant water droplets may cause the appearance of rust on your stainless steel turntable. However, the turntable is made of non-corrosive material and will NOT rust.
4. Spare plug seal is including in the packaging, this is not required until the unit starts to leak water through the rubber seal. (In most situations this will not need replacing).

1. The Scrapeater's motor is whirring, but the grinding turntables are not turning.

This is due to the blades being jammed. Refer to the section resetting your Waste Disposal on page 6.

2. The Scrapeater is not turning on at all.

This may be due to the overload protector function being set off. Refer to the Section resetting your Waste Disposal on Page 6.

3. Do I have to install the Air Switch?

No, this is an accessory that does not need to be installed with the unit.

If you are not going to use the Air Switch, make sure the Air Switch is in the ON position before using your Waste Disposal (see page 5)

4. What if the unit is leaking?

Scrapeater is a sealed unit and should not leak. Proper installation is required to ensure that all parts are connected correctly.

5. What CAN'T be put down the Scrapeater?

- Corn Cobs
- Shells
- Large Bones
- Plastic or metal objects
- Hard Vegetable skins such as Pumpkin, Pineapple leaves or Banana Peel

6. Why is my Plug difficult to pull out?

The plastic seal around the plug is can be a bit stiff when it is new.

It needs to be tight to ensure your sink stays full of water.

Over time the plastic will loosen up. As an interim measure we suggest applying a small amount of cooking oil to the inside of the Sink Flange.



















7. For more FAQ's and Care Instructions, visit our website

www.robinhood.co.nz/waste-disposers/cleaning-maintenance

Safety

Warning:

When using electrical appliances, basic precautions should always be followed, including the following:

-  Do not disassemble, refit or repair the waste disposal by yourself.
-  The appliance must be installed so that reset buttons and reversing switches are readily accessible.
-  To reduce risk of injury. Close supervision is necessary when the appliance is used near children.
-  Do not put fingers or hands into the waste disposal unit.
-  Switch off or unplug the appliance before attempting to free a jammed rotor with an implement.
-  Turn the power switch to the off position before attempting to clear a jam or remove an object from the disposer.
-  When attempting to loosen a jam in the waste disposal use the hexagonal wrench provided. See operating instructions for further details.
-  When attempting to remove objects from the waste disposal use long handed tongs or pliers.
-  When the waste disposal is not in use, leave the sink drain plug in place to reduce the risk of Objects falling into the disposer.
-  The appliance must be installed so that the reset button is readily accessible.
-  Do not use hot water when grinding food waste. Cold water helps in solidifying the waste, allowing the disposer to effectively grind the waste.
-  This appliance is not intended for use by young children or infirm persons unless they have been adequately supervised by a responsible person to ensure that they can use the appliance safely.
-  Young children should be supervised to ensure that they do not play with the product.
-  Your Robinhood Waste Disposal is designed for grinding food waste only. Do not attempt to grind the following:
 -  Metal: Silverware, nails, tacks wire, bread ties, staples.
 -  Glass: Jars, bottles, pieces of pottery or crockery.
 -  Dye or drain cleaning chemicals.
 -  Excessive quantities of fat or grease.

With proper use and care your Robinhood Waste Disposal will provide you with many years of trouble free service.

Product Approvals and Ratings

Product approval number	Spectrum Test report Number 4320
Product rating	390W (1.49A) Max at 240V 50Hz 520W (2.16A) Max at 240V 50Hz
/Electric approval AS/NZS	AS/NZS 60335.2.16:2006
EMC AS/NZS	CISPR14:2003

Warranty Certificate (New Zealand)

Terms and Conditions

The following conditions apply in respect of the warranty given in this certificate:

1. Monaco Corporation Limited ("Monaco") warrants the following Robinhood products against manufacturing defects and faulty materials, under normal use and subject to the exclusions in this certificate, for a period of:
Rangehood, Ovens, Cooktops, Dishwashers, Waste Disposals - 24 months from date of original purchase for domestic use.
Uniduct - 12 months from date of original purchase for domestic use.
Ironing centre - 12 months from date of original purchase for domestic use.
Taps, including Pull-out and Mixer taps - 5 years on parts only from date of original purchase domestic for use, 24 months parts and labour from date of original purchase for domestic use
Sinks sets - 5 years on stainless steel sink including draining bench from date of original purchase for domestic use, 6 months on all stainless steel accessories, including wire rack, colander and tray from date of original purchase for domestic use.
Laundry Tub - 5 years on stainless bowl, 24 months on Tap, Cabinet and other components from the date of original purchase for domestic use.

"Original purchase", when used in this certificate, means purchase by the customer directly from Monaco or one of its approved suppliers.

2. This warranty is limited to the repair or replacement, at our option, within the warranty period of any component part which we at our discretion determine to contain faulty materials or a manufacturing defect in breach of this warranty. This warranty is subject to terms and conditions set out in this certificate.
3. The warranty only applies within New Zealand.
4. The customer must produce the original invoice or other purchase documentation as proof of the original purchase date.

Warranty exclusions

1. The warranty does not apply where, in Monaco's opinion:
The defect is caused by misuse, wear and tear, dirt, fire or accidental damage.
The product has been repaired or serviced by an unauthorised person.
The product was not installed in accordance with our instructions.
The product was purchased overseas or was not designed for use in New Zealand.
The product was not used, cleaned or cared for in accordance with our instructions.
The product was used outdoors.
2. In addition, this warranty does not extend to damage or defects which in our opinion, directly or indirectly arise from or are due to:
Exposing the product to acidic or corrosive materials or chemicals such as dyes, solvents, denture cleaner or acetone;
Using inappropriate household cleaning products such as abrasive cream or powder cleansers, furniture polish, bleach, mentholated spirits, drain cleaners, sugar soap, metal pads and strongly alkaline or acidic cleaners;
Heat damage, including from washing the product at high temperatures;
Impact or mishandling the product, including the impact caused by objects scraped along, thrown or dropped on the product surface or excessive weight being placed on the product;
Structural or support changes in or affecting the building or the application where the product has been installed;
Failure to clean or maintain the product as recommended; or
any other causes specified in the product information as being excluded from this warranty.
3. Variations with the colour or gloss within the product or any ageing or fading of colour, shine or gloss level over time are not covered by this warranty. The warranty does not cover visual imperfections or blemishes in the surface and edges of the product that were not brought to your supplier's attention at the time you inspected the product.
4. Costs incurred on installation or removal of a product, or any reinstallation of a product, or any associated costs, are not covered by this warranty.
5. Monaco will not be liable for consequential or indirect loss or damage whatsoever and however arising out of or in connection with the supply, performance or removal of the product, including (but not limited to) loss of profit, loss of revenue, loss of contract, loss of goodwill or increased cost of workings, even if due to the negligence of Monaco or any of its approved suppliers, employees or agents.
6. Charcoal filters and light bulbs are not covered by this warranty
7. This warranty and the statements contained in this certificate or other documents given to you do not exclude, restrict or modify the application of any term implied into this warranty by statute, provided that (to the extent any statutory provision permits Monaco to limit its liability for a breach of an implied condition or warranty) Monaco's liability for such breach is limited to the payment of the cost of replacing the product, repairing the product or acquiring an equivalent product.
8. Subject to clause 5, our obligations under this warranty are limited to those set out in this certificate, and this warranty is expressly instead of all other warranties, express or implied, including any implied warranty of merchantability or fitness for a particular purpose and notwithstanding any course of dealing between the parties or custom and usage in trade to the contrary.

Terms and conditions are subject to change.

New Zealand

Monaco Corporation Ltd
Telephone: (09) 415 6000
Facsimile: (09) 415 7400
Email: enquiries@robinhood.co.nz
www.robinhood.co.nz

