

Description: **ROBINHOOD WASTE DISPOSAL – SCRAPEATER SEII SERIES**

Model Numbers: **SEII500Q, SEII500QA, SEII750QA**

Typical design



Dimensions

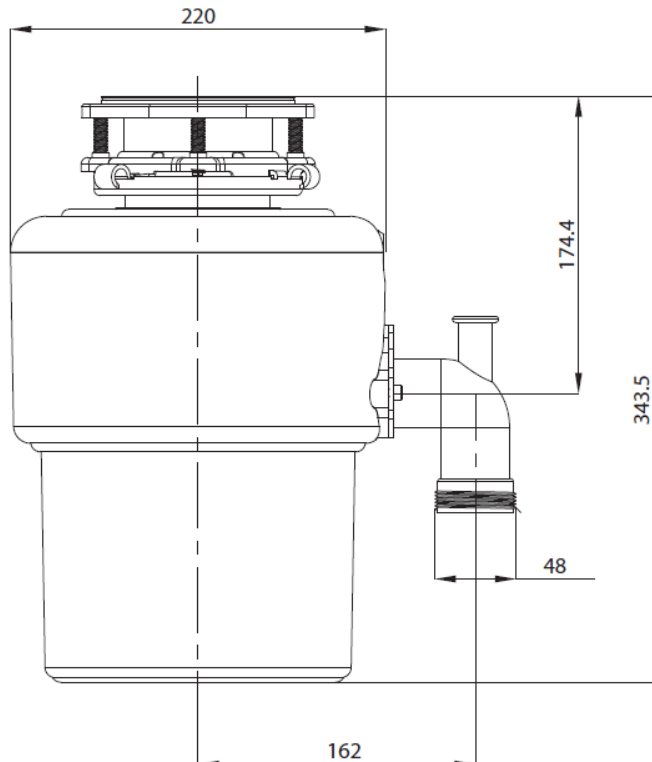

Specifications

Wattage / Horsepower per model:

Model	Watts / HP	Noise insulation	Air Switch
SEII500Q	370w (1/2 HP)	Yes	
SEII500QA	370w (1/2 HP)	Yes	Yes
SEII750QA	600w (3/4 HP)	Yes	Yes

Features:

- Three-stage grinding system effectively liquidises food scraps and reduces the chances of your machine clogging or jamming.
- An extra layer of sound insulation around its body keeps noise to a minimum.
- Triple-point mounting system to eliminate chances of any under-sink leaks
- Intelligent motor construction allows maximum torque on start up and high speed during operation.
- Stainless steel swivel impellers reduce the risk of jams.
- High quality cast stainless steel grinding components are robust and efficient.
- Overload switch protects the motor if you overfeed your Scrapeater.
- Standard pipe connections fit directly onto your S&P trap, and the motor plugs directly into your under-sink power point without the need for wiring.
- SEII500QA and SEII750QA both feature an air switch.

All models

Gross Weight: 7.8kg

Carton Volume: 0.026m³

Carton Dimensions: 230mm x 230mm x 395mm

Approvals

Product approval number	Nemko Shanghai Ltd (Shenzhen Branch) Report No: 310175 (Main Report: 235449) Issued: 21 July, 2016
Product rating	SEII500Q/QA 370W Max at 240V 50Hz SEII750QA 600W Max at 240V 50Hz
Electric approval AS/NZS	AS/NZS 60335.2.16:2006 Test Standard: IEC 60335-1:2010 (Fifth Edition) & IEC 60335-2-16:2002 (Fifth Edition) + A1:2008 + A2:2011 Test Procedure: CB Scheme
EMC AS/NZS	CISPR14:2003

New Zealand

Monaco Corporation Ltd
Telephone: (09) 415 6000
Facsimile: (09) 415 7400
Email: enquiries@robinhood.co.nz
www.robinhood.co.nz

Australia

Shriro Australia Pty Ltd
ABN 28 002 386 129
Telephone: 1800 648 556
Facsimile: 1800 628 577
Email: enquiries@robinhood.com.au
www.robinhood.com.au