

Description: **ROBINHOOD WORKSTATION SUPERTUB SPLASH BACK**
Model Number: **SB1200**

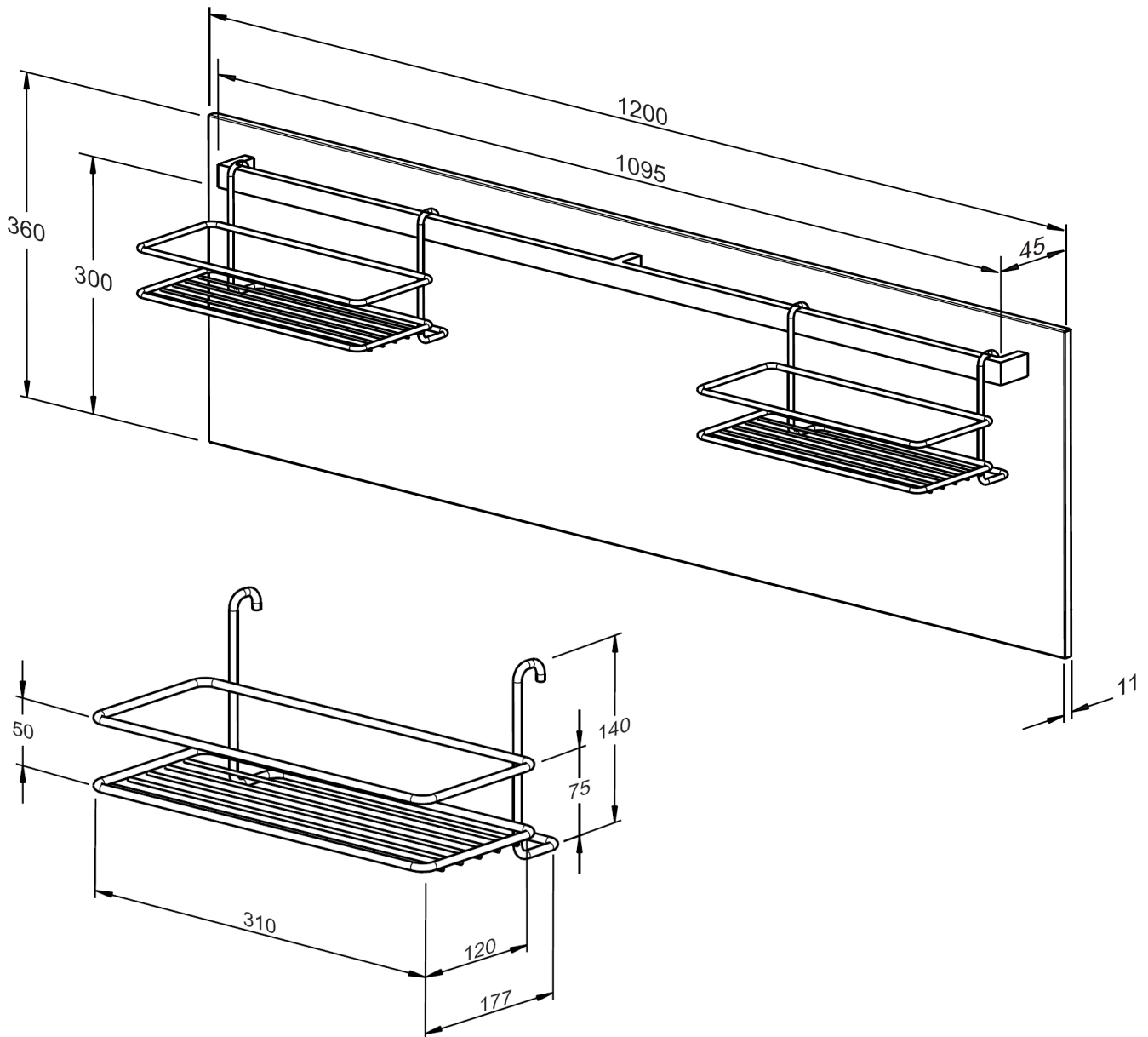

All dimensions in mm
Model may vary slightly from images pictured

Overview

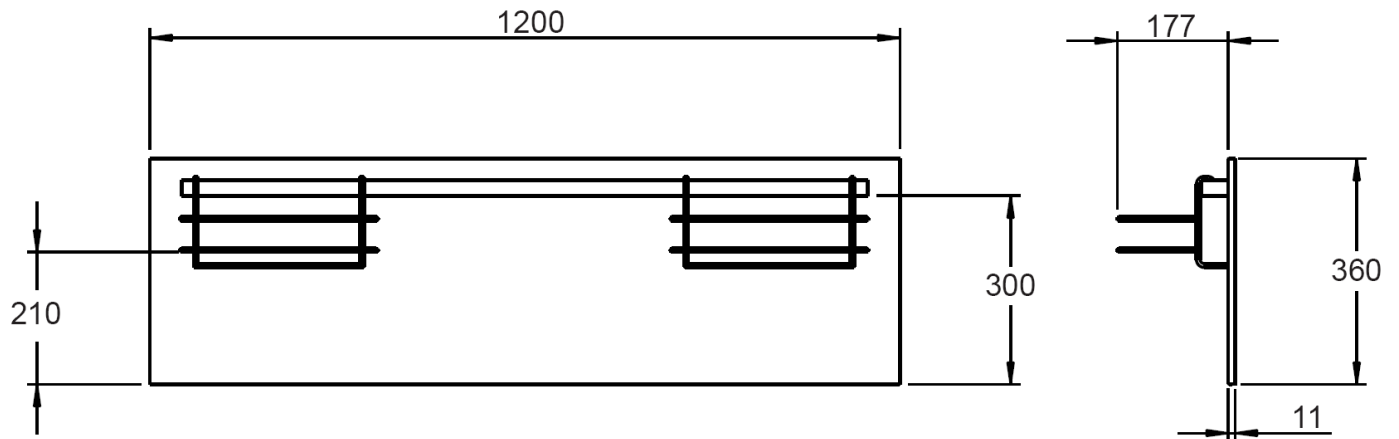

Contents of packaging:

- 1 x splash back
- 1 x stainless steel handle
- 2 x chrome baskets
- 1 x installation kit

Typical equipment required:

- electric drill
- screwdriver
- tape measure
- spirit level

Installation

1. Fix handle using fixing screws and washers supplied.

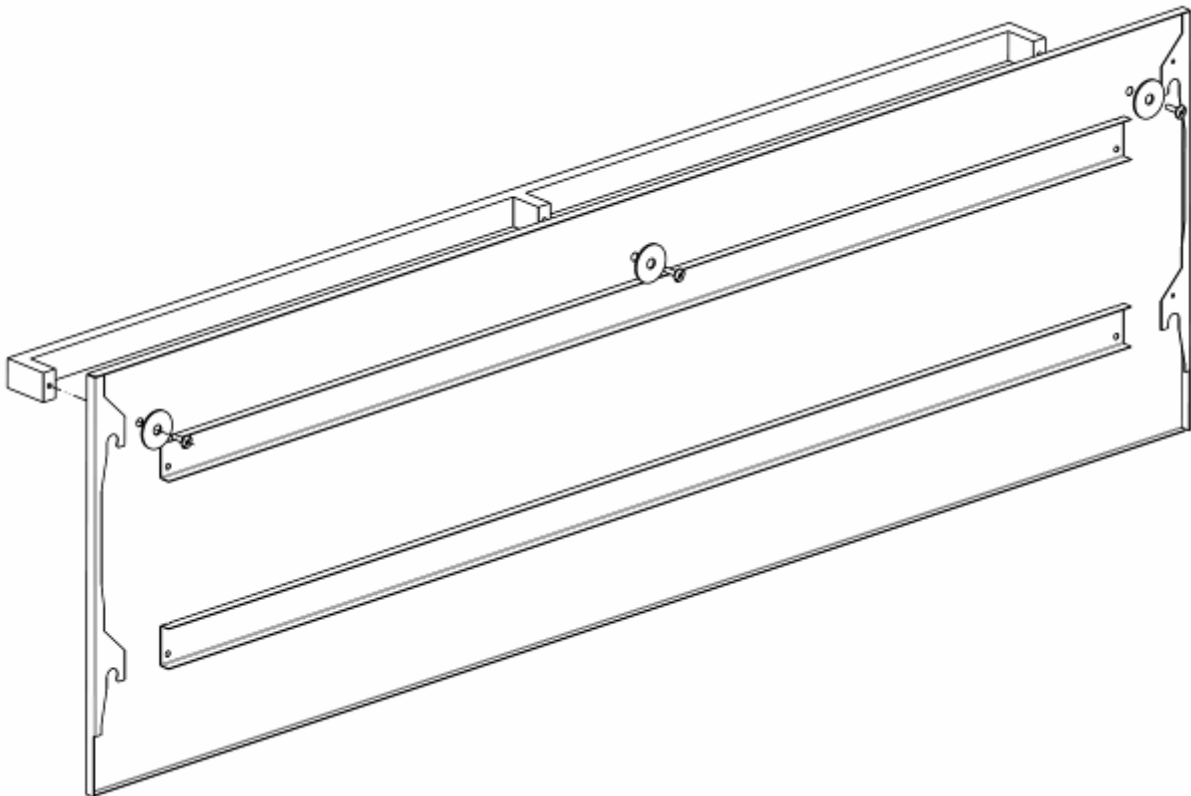

Installation - continued

2. Fix mounting screws and cup washers to the wall using the dimensions given below. Mounting to a stud is recommended. However, if fitted to other wall linings (plasterboard, concrete etc) suitable wall fixings will be required.

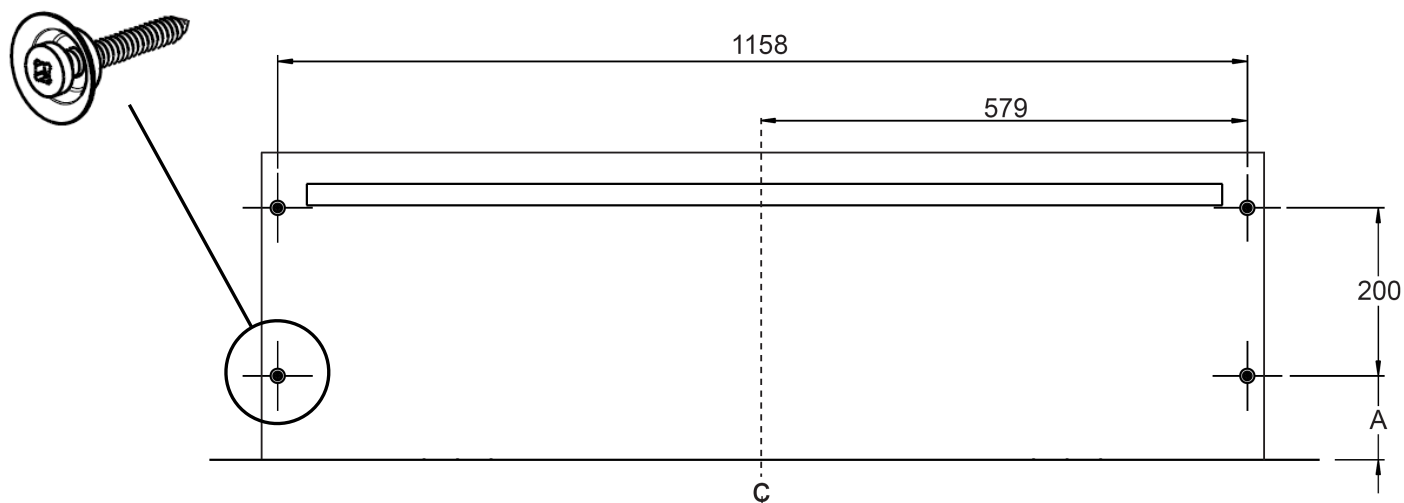

- A** Distance from the bench top to the lower fixing screw

100mm flush fit between the bottom surface of the splash back and the bench top

103mm allows a 3mm gap between the splash back and bench top if **sealing** is required

3. Hang splash back from the cup washers.

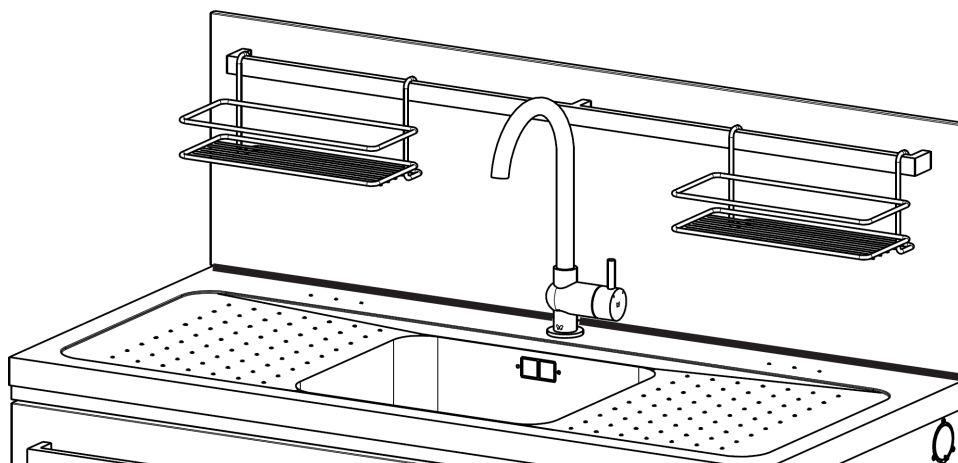

Cleaning and maintenance

Powder coated surfaces must not be cleaned with abrasive or chemical cleaners. To keep the splash back looking its best, wipe regularly with a damp soft cloth. A mild soap and water solution may be used to remove stubborn dirt. Under no circumstances should harsh detergents (including chemical cleaners) such as bleaches, scourers or any abrasive cleaner be used as these products may irreparably damage the surface finishes of the splash back.

NB. Their use will render the warranty void.

For any other problems please call help line on NZ 0800 760 667 or AUS 1800 648 556

Warranty Certificate (New Zealand)

The benefits conferred hereunder are in addition to all other rights and remedies in respect of the product which the purchaser has by virtue of the Consumer Guarantee Act and similar legislation, and nothing contained in this Certificate shall in any way limit the purchaser's rights under such legislation.

Terms and Conditions

The following conditions apply in respect of the warranty given in this certificate:

1. Robinhood warrants this product against manufacturing defects and faulty materials for a period of:
2. **Rangehood** – 24 months from date of original purchase.
3. **Supertub** – Lifetime on stainless bowl, 5 years on single lever unit, 1 year on other components from date of original purchase.
4. **Ironing Centre** – 12 months from date of original purchase.
5. **Uniduct** – 12 months from date of original purchase. For commercial use 3 months from date of original purchase.
6. This warranty is limited to the repair or replacement free of charge within the warranty period of any component part which Robinhood at its discretion determines to be faulty. Such warranty is subject to terms and conditions set out below.
7. The warranty applies within New Zealand.
8. The customer must produce the original invoice or other purchase documentation as proof of the purchase date.
9. To abide by the guarantee please complete the details below and keep it with your purchase invoices.
10. In the event that service is required, contact the source from whom the product was purchased. It will be the responsibility of that sales agent to direct the purchaser to an authorised service centre or replace the defective parts. All costs of labour performed outside an authorised Service Centre will not be the responsibility of Robinhood. Alternatively contact Robinhood.

Warranty exclusions

1. The warranty does not apply for the following:
 - If defect is caused by misuse, wear and tear, dirt, fire or accidental damage.
 - If the product has been repaired or serviced by an unauthorised person.
 - If installed contrary to Robinhood instructions.
 - Products purchased overseas or not designed for use in New Zealand.
 - Normal user adjustments or customer instruction on the product's operation.
 - Abnormal product performance as a result of incorrect installation or deviation from specified instructions.
 - All costs incurred on installation or removal.
 - If the product is used outdoors.
2. A charge shall be made if the service person finds the product is functioning correctly.
3. Paint finishes and the colours in plastics are fully covered by this warranty for 12 months from date of purchase.

Should service be required please contact the store where you purchased your Robinhood product. If you require any further advice or information on Robinhood product feel free to contact:

Robinhood

Free Phone: 0800 760 667
Free Fax: 0800 276 246
Email: enquiries@robinhood.co.nz
Website: www.robinhood.co.nz

Name of purchaser			
Address			
Date of purchase	Model number	Serial No/Date stamp	
Name of supplier			
Address			
Invoice number			

Complete these details and keep it with your purchase invoice.

DO NOT POST

Warranty Certificate (Australia)

The benefits conferred hereunder are in addition to all other rights and remedies in respect of the product which the purchaser has by virtue of the Trade Practices Act 1974 and similar State and Territory legislation and nothing contained in this Certificate shall in any way limit the purchaser's rights under such legislation.

Terms and Conditions

The following conditions apply in respect of the warranty given in this certificate:

1. Robinhood warrants this product against manufacturing defects and faulty materials for a period of:
2. **Rangehood** – 24 months from date of original purchase.
3. **Supertub** – Lifetime on stainless bowl, 5 years on single lever unit, 1 year on other components from date of original purchase.
4. **Ironing Centre** – 12 months from date of original purchase.
5. **Uniduct** – 12 months from date of original purchase. For commercial use 3 months from date of original purchase.
6. This warranty is limited to the repair or replacement free of charge within the warranty period of any component part which Robinhood at its discretion determines to be faulty. Such warranty is subject to terms and conditions set out below.
7. The warranty applies within the Commonwealth of Australia.
8. The customer must produce the original invoice or other purchase documentation as proof of the purchase date.
9. To abide by the guarantee please complete the details below and keep it with your purchase invoices.
10. In the event that service is required, contact the source from whom the product was purchased. It will be the responsibility of that sales agent to direct the purchaser to an authorised service centre or replace the defective parts. All costs of labour performed outside an authorised Service Centre will not be the responsibility of Robinhood. Alternatively contact Robinhood or your nearest Service Agent as listed below.

Warranty exclusions

1. The warranty does not apply for the following:
 - If defect is caused by misuse, wear and tear, dirt, fire or accidental damage.
 - If the product has been repaired or serviced by an unauthorised person.
 - If installed contrary to Robinhood instructions.
 - Products purchased overseas or not designed for use in New Zealand.
 - Normal user adjustments or customer instruction on the product's operation.
 - Abnormal product performance as a result of incorrect installation or deviation from specified instructions.
 - All costs incurred on installation or removal.
 - If the product is used outdoors.
2. For warranty service outside of Capital City metropolitan area or 30 km from nearest authorised service agent the purchaser shall be liable for travelling expenses and cost of transport of the product or parts to and from the Service Agent
3. Paint finishes and the colours in plastics are fully covered by this warranty for 12 months from date of purchase.
4. A charge shall be made if the service person finds the product is functioning correctly.

Should service be required please contact the store where you purchased your Robinhood product. If you require any further advice or information on Robinhood product feel free to contact:

Robinhood

Free Phone: 1800 648 556
 Free Fax: 1800 628 577
 Email: enquiries@robinhood.com.au
 Website: www.robinhood.com.au

Area	Service agents	Contact details
Victoria	J.A. Appliances	Tel: (03) 8371 9100 Fax: (03) 9355 8644 Email: jaappliances@statewideservices.com.au
New South Wales (Sydney, North Coast)	All General White Goods Services	Tel: (02) 8788 8666 Fax: (02) 9756 1091 Email: service@agw.com.au
New South Wales (Country, Wagga Wagga)	K J Wardens	Tel: (02) 6922 8600 Fax: (02)6922 8611
ACT	K J Wardens	Tel: (02) 6280 5736 Fax: (02) 6280 5376
Tasmania	BSH Electrical Pty Ltd	Tel: (03) 6231 0255 Fax: (03) 6334 1044
South Australia	Ivesons Electrical	Tel: (08) 8297 2033 Fax: (08) 8297 7881
Western Australia	J.H. Wilberforce	Tel: (08) 9340 6222 Fax: (08) 9340 6262
Queensland	Terry Hayes Agencies	Tel: 1800 6485561 Fax: (07) 3262 1217 Email: info@terryhayesagencies.com

Name of purchaser			
Address			
Date of purchase	Model number	Serial No/Date stamp	
Name of supplier			
Address			
Invoice number			

Complete these details and keep it with your purchase invoice.

DO NOT POST

ISO 9001/2000 CERTIFICATION

New Zealand

Robinhood Ltd
 Telephone: 0800 760 667
 Facsimile: 0800 276 246
 Email: enquiries@robinhood.co.nz
 www.robinhood.co.nz

Australia

Robinhood PTY Ltd
 Telephone: 1800 648 556
 Facsimile: 1800 628 577
 Email: enquiries@robinhood.com.au
 www.robinhood.com.au

