

SUPERTUB LAUNDRY INSERT

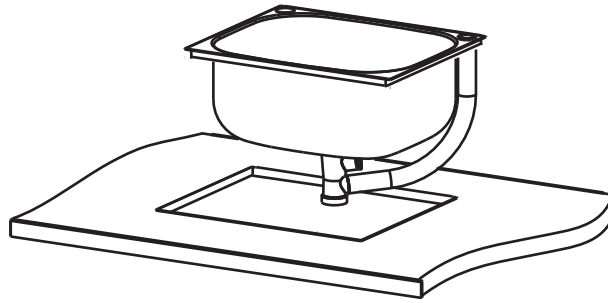

LAUNDRY TUB ASSEMBLY

1. Remove tub and waste from box and unwrap all parts.
2. Insert screw through waste grill (Dia.A).
3. Place seal onto waste body (With ribs facing up) (Dia.A).
4. Place tub on it's side, put waste body and seal on underside of tub then fit waste grill complete with screw into tub, tighten screw.

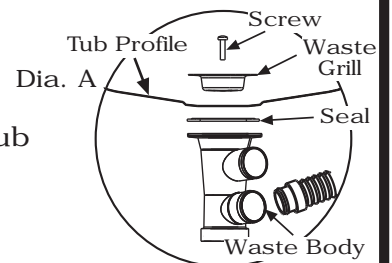

The Waste Hose can be connected to either side of the Tub. Waste connection holes are located on the top of tub (Dia.B). It maybe necessary to re-orient the waste body on the laundry tub. Loosen the screw on the waste body. Adjust to suit, ensure waste grill is centred in the tub then **TIGHTEN** to avoid flooding.

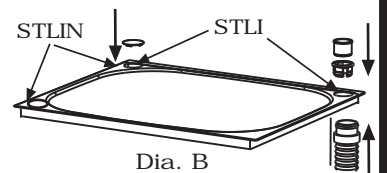

- Ⓐ Waste Stay Ⓑ Waste Lock
- Ⓒ Grommet Ⓓ Cable Tie

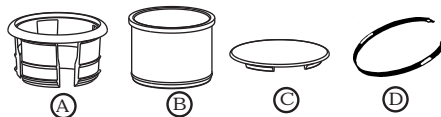

Refer to Dia. B and C for the following instructions.

5. Insert the Waste Stay Ⓐ into the mounting hole.
6. Push in the flexible waste hose into the Waste Stay Ⓐ. Ensure the waste hose is firmly inserted to Waste Stay Ⓐ.
7. Insert the Waste Lock Ⓑ to Waste Stay Ⓐ.
8. Use the Cable Tie Ⓓ supplied to secure the waste hose to Waste Stay.
9. Insert the Grommet Ⓒ to cover the hole in the tub not in use.
10. **IMPORTANT:** Ensure flexible waste is correctly fitted to the Waste Body.

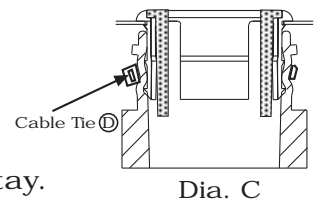

MANUFACTURED IN NEW ZEALAND BY:
ROBINHOOD LIMITED
 P.O. BOX 51 201, PAKURANGA, AUCKLAND, N.Z.
 TEL: +64 9 272 5129 • FAX: +64 9 272 5148
 ISO9001 Certified

SUPERTUB LAUNDRY INSERT

FITTING INSTRUCTION

1. Mark out desired position as per cut out detail (Dia.D).
2. Fit 10 fixing clips supplied to rail on tub in appropriate positions.
3. Apply sealant to outer flange.
4. Place Insert Tub in position.
5. Starting from the centre of the Tub, tighten fixing clips working to outside edges.
6. DO NOT OVERTIGHTEN
7. Because of varying thicknesses of the Bench Tops, packing blocks may be necessary.

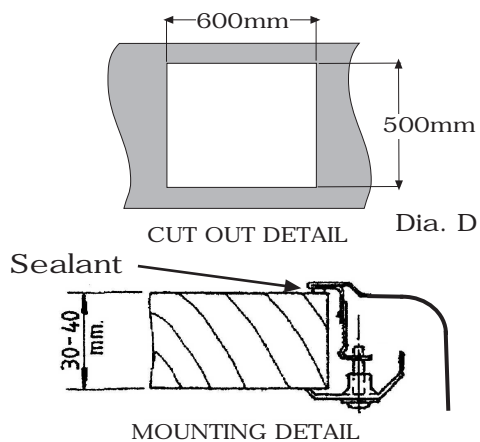

FOR SERVICE OR ADVICE CONTACT:

in New Zealand
Robinhood Ltd
Tel 0800 760 667, Fax 0800 276 246,
Email enquiries@robinhood.co.nz

in Australia
Robinhood Australia Pty Ltd A.C.N. 104298062
Tel 1800 648 556, Fax 1800 628 577,
Email enquiries@robinhood.co.nz

in Singapore
Multico Building Products Pte Ltd
Tel 65 283 8888, Fax 65 283 8138

in Thailand
Verasu Limited Partnership
Tel (662) 254 8100, Fax (662) 253 1574

MANUFACTURED IN NEW ZEALAND BY:
ROBINHOOD LIMITED
P.O. BOX 51 201, PAKURANGA, AUCKLAND, N.Z.
TEL: +64 9 272 5129 • FAX: +64 9 272 5148
ISO9001 Certified