

PRODUCT & TECHNICAL SHEET

Brand



Model Number : RCP6WH, RCP6SS
 RCP9WH, RCP9SS
 Model Description : Robinhood Callisto Powerpack
 Colours : White, Stainless Steel
 Sizes : 600mm and 900mm

SPECIFICATIONS

TECHNICAL DATA :

- 40 watt incandescent light
- Centrifugal 3 speed motor 80 watt
- 240 Volt / 50 Hertz
- Tested to CISPR14-1:2000 (radio frequency interference)
- Electrical approval AS/NZS 3350.2.31:1997
- Performance tested to IEC 665

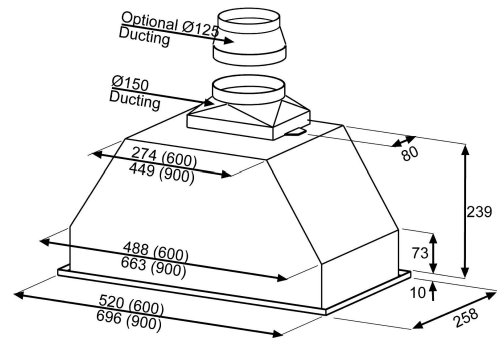

WEIGHT (kg) :

600mm 7.3kg
 900mm 8.4kg

CARTON DIMENSION (mm) :

615 x 350 x 370 (600 unit)
 815 x 350 x 370 (900 unit)

Volume (m³) :

0.08
 0.11

Rangehood Dimensions:

520mm (600 unit) – designed for a 600mm hob
 696mm (900 unit) – designed for a 900mm hob

PERFORMANCE DATA :

	Max Airflow (m/hr ³)	Noise (dB)
Speed 1 top duct	220	46.5
Speed 2 top duct	340	53.5
Speed 3 top duct	500	57.4

FEATURES AND BENEFITS

FEATURES

- Twin 40 watt lights
- 3 speed motor
- Micro mesh filters
- Motor off/speed 1/speed 2/speed 3 switch
- Powerful centrifugal motor
- Powder coated paint finish & stainless steel
- Fully integrated
- Choice of 125mm or 150mm duct adaptor
- NB reducer included
- Fire retardant plastic parts
- Charcoal filter disc directly attached to motor
- Safety thermal overload switch

BENEFITS

- Provides plenty of light for cooking
- Allows flexible power control
- Attractive styled filter which is dishwasher proof for easy cleaning
- Allows various power settings
- Moves large volumes of air when long ducting is required
- Clean, smooth finish with attractive looks
- Designed to fit conveniently and unobtrusively into the cabinetry of your kitchen
- Allows flexible ducting options
- 150mm to 125mm
- Plastic is self-extinguishing, preventing spread of any flame
- Efficient capture of grease laden odours
- Provides peace of mind by automatically switching off if a fire occurs and thereby prevents the fire being sucked up into the ceiling

