

PRODUCT & TECHNICAL SHEET

Brand



Model Number : RIIC9PLUS
Model Description : Arco Island Plus Canopy – Glass
Colours : Stainless Steel and Glass
Sizes : 900mm



SPECIFICATIONS

TECHNICAL DATA :

- 4 X 20 watt halogen lights
- 180mm centrifugal fan motor 250 watt
- 240 Volt / 50 Hertz
- Tested to EMC AS/NZS4417 (radio frequency interference)
- Electrical approval AS3310-1992
- Performance tested to AS2682-1984

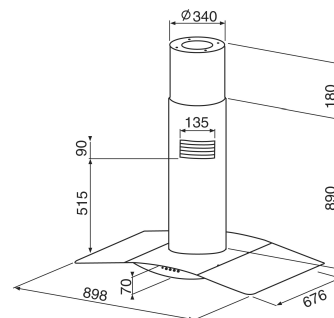

WEIGHT (kg) :

RIIC9G 45kg

CARTON DIMENSION (mm) :

850 x 1100 x 630mm

Volume (m³) :

0.662

PERFORMANCE DATA :

	Max Airflow (m/hr ³)	Noise (dB)
Speed 1 top duct	450	54
Speed 2 top duct	780	63
Speed 3 top duct	960	70

FEATURES AND BENEFITS

FEATURES

- Stainless steel grain runs one way
- Push button for lights and speed selection
- Tempered tinted glass
- Safety rail
- Extra fine Micro Mesh filter
- Four 20 watt halogen lights
- Super high performance in line centrifugal 3 speed motor with computer balanced steel blades and twin air intakes
- 2 piece adjustable stainless steel flue with optional extensions
- Ducted or recirculated
- 150mm exhaust outlet
- Safety thermal overload switch

BENEFITS

- Creates a superb finish
- Simple selection of required speed which are easy to clean
- Latest European kitchen fashion
- Protects access to edge of glass
- Attractive styled filter which is dishwasher proof for easy cleaning
- Ensures perfect light dispersion over the entire cooking area
- Exceptional performance with a net airflow of 720cm³ tested to Australian Standards AS2682
- Can be adjusted to fit most kitchen situations
- Provides the option of external exhaust of odours or recirculating with a charcoal filter
- The larger outlet ensures greater volumes of air are expelled from the kitchen
- Provides peace of mind by automatically switching off if a fire occurs and thereby prevents the fire being sucked up into the ceiling

